

X2G100SD12P2

HIGH POWER SPT+ TYPE 2-PACK IGBT MODULE



1200V
100A

PACKAGE : M2

FEATURES

- Soft Punch Through (SPT+) Technology
- Fast & soft inverse CAL diodes
- 10us short circuit capability
- Positive $V_{CE(on)}$ temperature coefficient
- Industry standard package

CIRCUIT DIAGRAM

PRELIMINARY

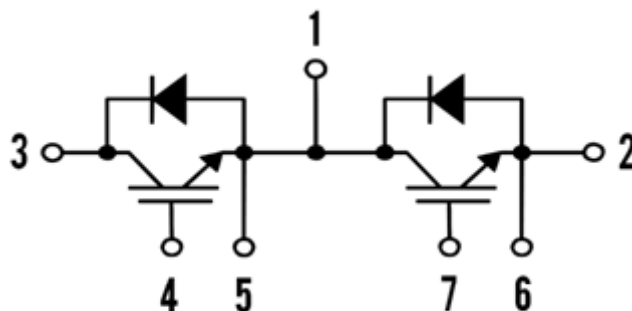

APPLICATIONS

- High power inverter
- Switched mode power supplies (SMPS)
- UPS
- Electrical welding machine

ABSOLUTE MAXIMUM RATINGS

$T_c=25^{\circ}\text{C}$, unless otherwise specified

Symbol	Parameter	Conditions	Ratings	Unit
V_{CES}	Collector-emitter voltage	-	1200	V
I_C	DC-collector current	$T_C = 25^{\circ}\text{C}$	150	A
		$T_C = 80^{\circ}\text{C}$	100	A
I_{CRM}	Repetitive peak collector current	$T_p=1\text{ms}$ $T_C = 80^{\circ}\text{C}$	200	A
V_{GES}	Gate-emitter peak voltage	-	± 20	V
I_F	Diode continuous forward current	$T_C = 80^{\circ}\text{C}$	100	A
I_{FRM}	Diode repetitive peak forward current	-	150	A
$T_{vj,max}$	Maximum junction temperature	-	-40 ~ 150	$^{\circ}\text{C}$
$T_{vj,op}$	Operating temperature range	-	-40 ~ 125	$^{\circ}\text{C}$
T_{stg}	Storage temperature range	-	-40 ~ 125	$^{\circ}\text{C}$
V_{ISOL}	Insulation test voltage	50Hz, $t=1\text{ms}$	2.5	kV
M_S	Mounting screw torque	M6	3.0 ~ 6.0	N.m
M_t	Mounting terminals screw torque	M5	2.5 ~ 5.0	N.m

Technical information and specification subject to change without notice.

PRELIMINARY

ELECTRICAL CHARACTERISTICS OF IGBT

$T_J=25^\circ\text{C}$ unless otherwise specified

Symbol	Parameter	Min	Typ	Max	Unit	Conditions
$V_{CE(Sat)}$	C-E saturation voltage	-	1.8	-	V	$I_C = 100A, V_{GE} = 15V, T_{vj} = 25^\circ\text{C}$
		-	2.0	-	V	$I_C = 100A, V_{GE} = 15V, T_{vj} = 125^\circ\text{C}$
$V_{GE(th)}$	G-E threshold voltage	5.0	6.2	7.0	V	$I_C = 4mA, V_{CE} = V_{GE}$
I_{CES}	Zero gate voltage collector current	-	400	-	μA	$V_{GE} = 0V, V_{CE} = 1200V$
I_{GES}	G-E leakage current	-200	-	200	nA	$V_{GE} = \pm 20V$
R_{Gint}	Internal gate resistance	-	2.0	-	Ω	-
C_{ies}	Input capacitance	-	8.27	-	nF	$V_{GE} = 0V,$ $f = 1\text{MHz},$ $V_{CE} = 25V,$ $T_{vj} = 25^\circ\text{C}$
C_{oes}	Output capacitance	-	0.83	-		
C_{res}	Reverse transfer capacitance	-	0.62	-		
Q_g	Total gate charge	-	1050	-	nC	$V_{GE} = \pm 15V$
$t_{d(on)}$	Turn-on delay time	-	135	-	ns	$V_{CE} = 600V,$ $I_C = 100A,$ $V_{GE} = \pm 15V,$ $R_G = 10\Omega,$ $T_{vj} = 125^\circ\text{C}$
t_r	Turn-on rise time	-	60	-		
$t_{d(off)}$	Turn-off delay time	-	490	-		
t_f	Turn-off fall time	-	75	-		
E_{ON}	Turn-on Energy loss	-	12.4	-	mJ	
E_{OFF}	Turn-off Energy loss	-	10.8	-		

ELECTRICAL CHARACTERISTICS OF FRD

$T_J=25^\circ\text{C}$ unless otherwise specified

Symbol	Parameter	Min	Typ	Max	Unit	Conditions
V_F	Diode Forward Voltage Drop	-	1.6	-	V	$T_{vj} = 25^\circ\text{C}$
		-	1.6	-		$T_{vj} = 125^\circ\text{C}$
I_{rr}	Peak Reverse Recovery Current	-	51	-	A	$I_F = 100A$
Q_{rr}	Diode Recovery Charge	-	18	-	μC	$V_{CE} = 600V$ $V_{GE} = 15V$ $T_{vj} = 125^\circ\text{C}$

THERMAL AND MECHANICAL CHARACTERISTICS

$T_J=25^\circ\text{C}$ unless otherwise specified

Symbol	Parameter	Min	Typ	Max	Unit	Condition
$R_{th(j-c)}$	Junction-to-Case (IGBT Part, Per 1/2 Module)	-	0.15	-	K/W	
$R_{th(j-c)}$	Junction-to-Case (FRD Part, Per 1/2 Module)	-	0.54	-	K/W	
$R_{th(c-f)}$	Case-to-Heat Sink (With Thermal Compound)	-	0.04	-	K/W	
Weight	Module		220		g	

Technical information and specification subject to change without notice.

PERFORMANCE CURVES (I)

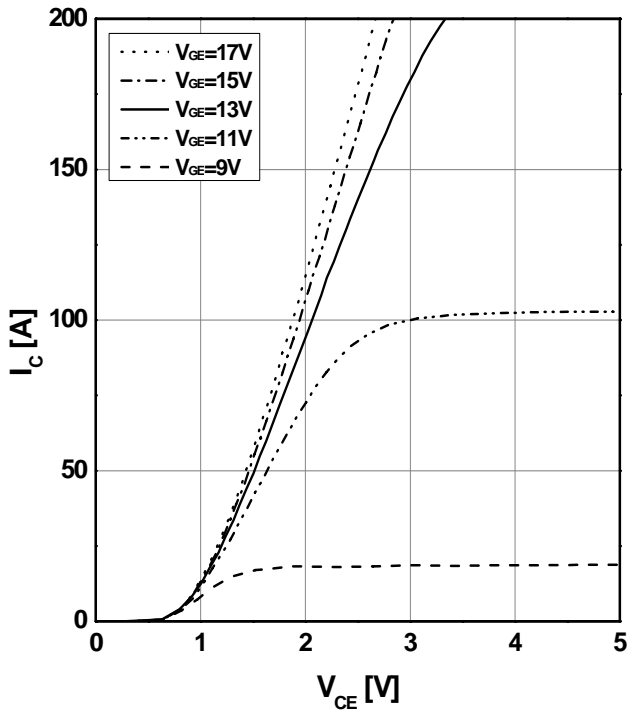

Fig1. Typical Output Characteristics

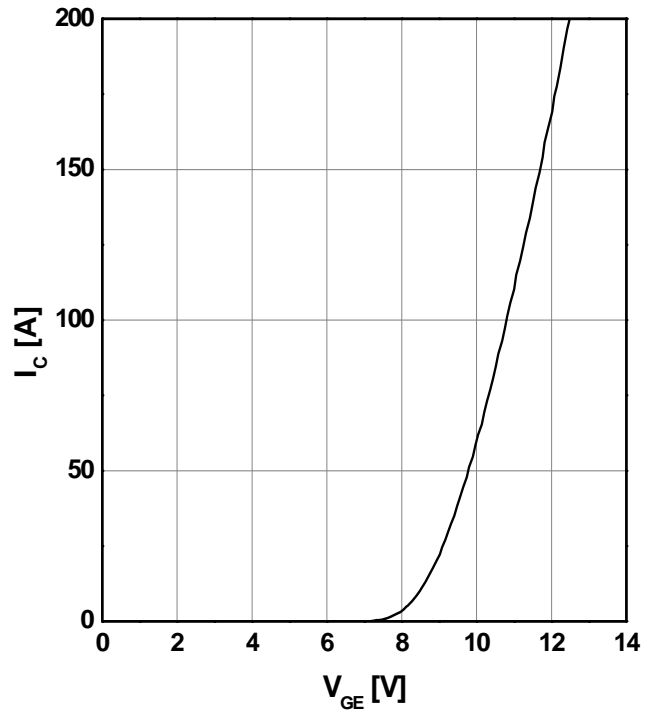

Fig2. Transfer Characteristics

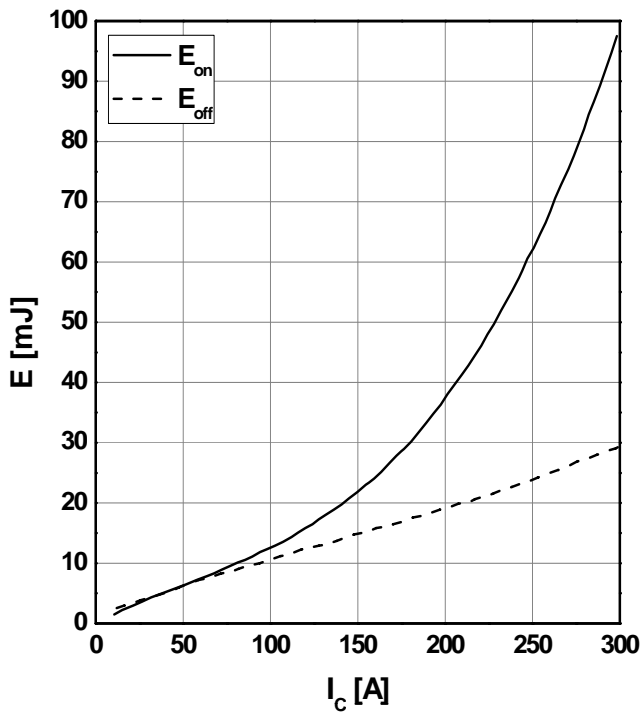

Fig3. Energy Loss vs. I_c

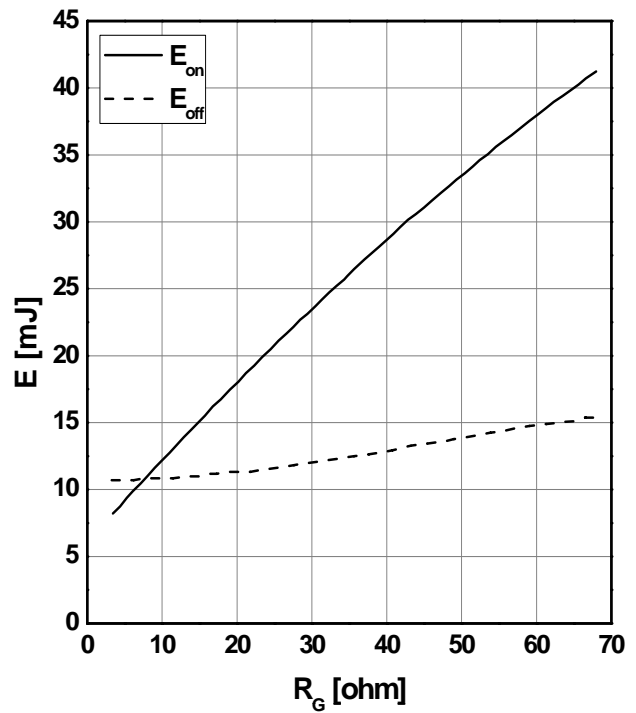

Fig4. Energy Loss vs. R_G

Technical information and specification subject to change without notice.

PERFORMANCE CURVES (II)

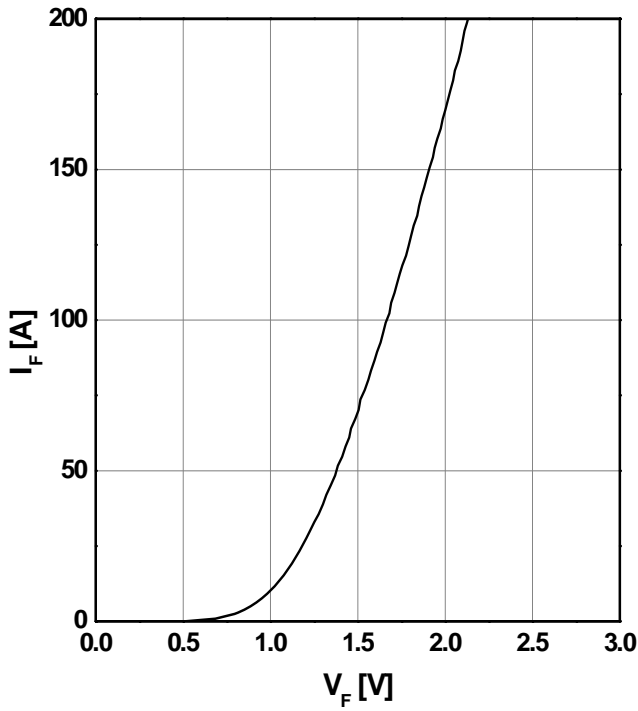

Fig5. DIODE Forward Characteristic

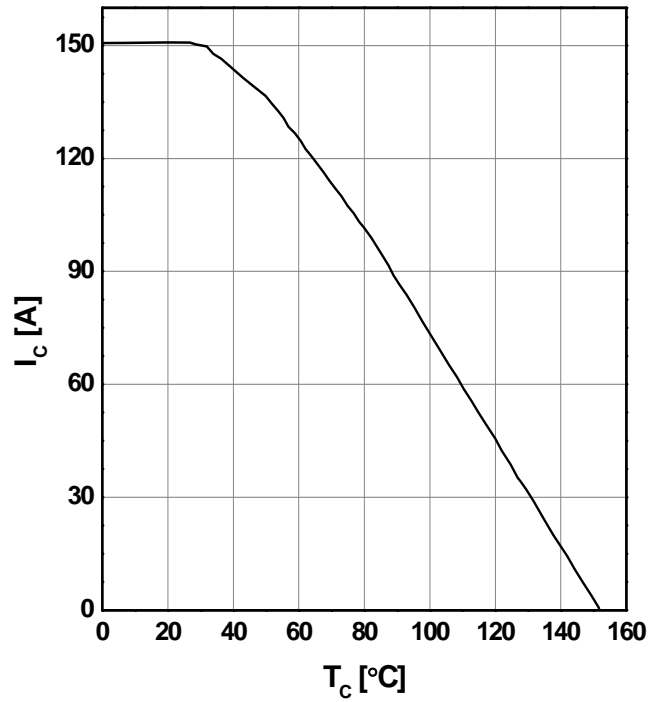

Fig6. Reverse Bias SOA (T_{vj} = 125°C)

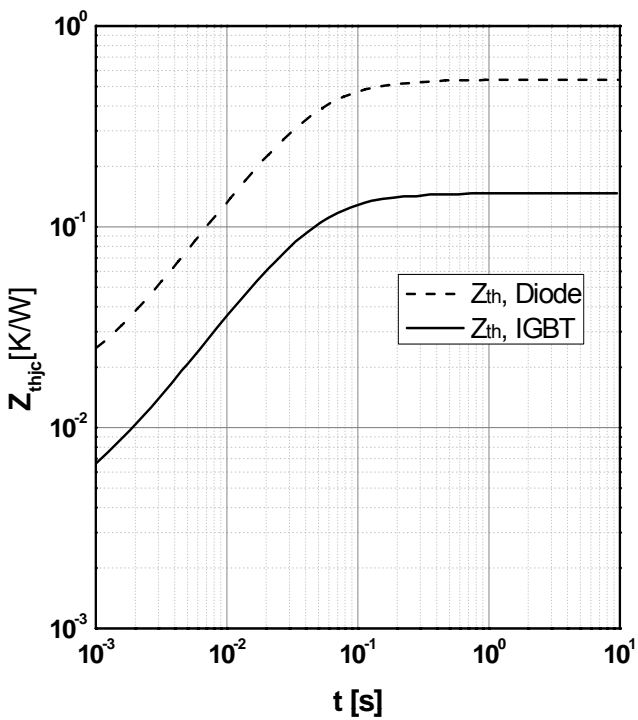

Fig7. Transient Thermal

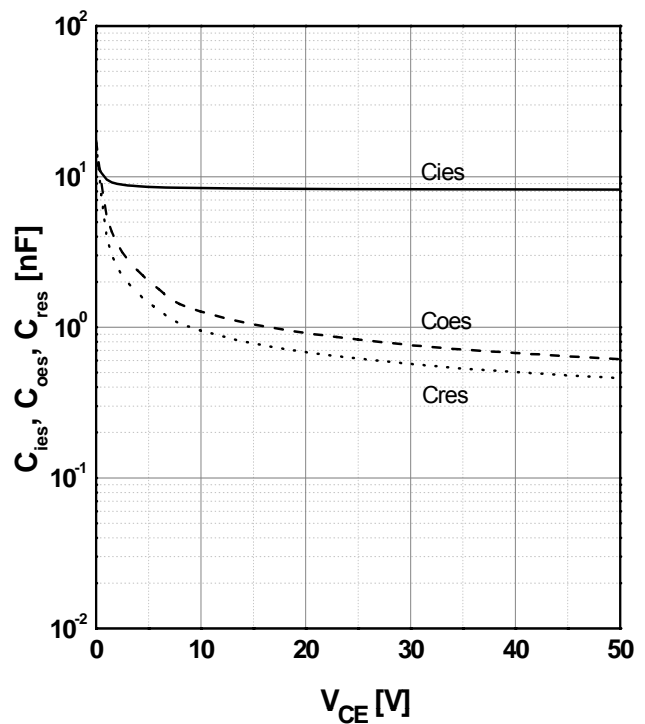

Fig8. Typ. Capacitance

Technical information and specification subject to change without notice.

