MANUAL

CURTISPMC

1204X/1205X
and 1209/1221
MOTOR CONTROLLERS

© 1999 CURTIS INSTRUMENTS, INC.

DESIGN OF CURTIS PMC 1200 SERIES
CONTROLLERS PROTECTED BY U.S.
PATENT NO. 4626750.

CURTIS

CURTIS PMC

235 East Airway Boulevard
Livermore, California 94568 USA
Tel: 925-961-1088
Fax: 925-961-1099
www.curtisinst.com

1204X / 1205X / 1209 / 1221 Manual
p/n 98796, Rev. D: May 1999

1204X / 1205X / 1209 / 1221 Manual
p/n 98796, Rev. D: May 1999
© 1999 CURTIS INSTRUMENTS, INC.

This electronic version of the 1204X/1205X/1209/1221 manual is offered as a convenience to our customers. You may download any or all of it.

If you would like a hard copy of the published manual, please order it by part number from the Curtis office nearest you.

The electronic version of the manual is identical to the printed version published in May 1999 with the following exceptions:

Minor corrections were made to the dimensions shown in Figure 3.

Bookmarks have been added to the electronic version to speed the process of going directly to a particular part of the document.

CURTIS INSTRUMENTS, INC.
200 KISCO AVENUE
MOUNT KISCO, NEW YORK 10549 USA
914-666-2971 FAX 914-666-2188

CURTIS PMC
235 EAST AIRWAY BOULEVARD
LIVERMORE, CALIFORNIA 94550 USA
925-961-1088 FAX 925-961-1099

*ADDITIONAL OFFICES located in
Bulgaria, China, England, France, Germany,
India, Italy, Japan, Netherlands, Puerto Rico,
Russia, Sweden, and Switzerland*

CONTENTS

1. OVERVIEW	1	=====
2. HARDWARE INSTALLATION	3	=====
Controller	3	=====
Throttle	5	=====
Other Hardware	8	=====
Main contactor	9	=====
Forward/reverse contactors	9	=====
Forward/reverse switches	9	=====
Emergency reverse relay	10	=====
Bypass contactor	10	=====
Keyswitch and interlocks	10	=====
Polarity protection diode	10	=====
Control wiring fuse	10	=====
Power wiring fuse	10	=====
3. WIRING	11	=====
Connections: Low Current	11	=====
Connections: High Current	12	=====
Wiring: Typical Installation	12	=====
KSI wiring	12	=====
Forward/reverse wiring	13	=====
Plug braking	14	=====
Freewheeling	14	=====
Emergency reverse	15	=====
Throttle pot wiring	16	=====
Standard potbox wiring	16	=====
Pots for twist-grip throttles	16	=====
Reduced speed operation	17	=====
Electronic throttle wiring	18	=====
Bypass wiring	19	=====

FIGURES

FIG. 1: Curtis PMC 1205X full-feature motor controller	1
FIG. 2: Mounting dimensions, Curtis PMC 1204X/5X controllers	3
FIG. 3: Mounting dimensions, Curtis PMC 1209/21 controllers.....	3
FIG. 4: Mounting dimensions, Curtis PMC potboxes PB-5, -6, -9, and -10	6
FIG. 5: Mounting dimensions, Curtis PMC footpedal	6
FIG. 6: Mounting dimensions, Curtis electronic throttle (ET series).....	7
FIG. 7: Typical installation, 1204X/1205X/1209/1221 controllers	8
FIG. 8: Basic wiring configuration, 1204X/1205X/1209/1221 controllers	13
FIG. 9: Control wiring for inhibiting plug braking, in order to allow freewheeling	14
FIG. 10: Wiring for emergency reverse (enhanced plug braking current).....	15
FIG. 11: Standard throttle pot, 0-5k Ω	16
FIG. 12: Bi-directional twist-grip throttle with 10 k Ω center-tapped, 4-terminal pot	16
FIG. 13: Bi-directional twist-grip throttle with a standard 20 k Ω pot and a controller with the optional 5k Ω throttle input	17

FIG. 14: Reduced speed operation (with standard
 (0–5kΩ pot) 17

FIG. 15: Curtis electronic throttle (ET series)
 with a controller having the optional
 0–5V throttle input 18

FIG. 16: Adjustment pots 23

FIG. 17: Guide to troubleshooting procedures 27

FIG. 18: Setup for bench testing 33

FIG. A-1: Block diagram, Curtis PMC
 1204X/1205X/1209/1221 controllers A-1

FIG. B-1: Pulse width modulation B-1

TABLES

TABLE C1: Electrical specifications, 1204X/1205X C-1

TABLE C2: Electrical specifications, 1209/1221 C-2

1

OVERVIEW

Curtis PMC Model 1204X/1205X and 1209/1221 electronic motor speed controllers are designed to provide smooth, silent, cost-effective control of motor speed and torque on a wide variety of industrial electric vehicles.

Fig. 1 Curtis PMC 1205X full-feature electronic motor controller.

Models 1204X, 1209, and 1221 have identical connections.



Like all Curtis PMC 1200 series controllers, the 1204X/1205X and 1209/1221 models offer superior operator control of the vehicle's motor drive speed. Key features of these controllers include:

- Infinite variable drive and brake control

- Power MOSFET design provides high efficiency (for reduced motor and battery losses) and silent operation

- High pedal disable (HPD) function monitors throttle status during turn-on and prevents operation until throttle has been returned to neutral [optional feature]

- Thermal protection and compensation circuit provides both under-temperature and overtemperature cutback, as well as steady current limit throughout the entire operating range

- Undervoltage cutback function protects against low battery voltage, including low voltage caused by external loads

[More Features](#)

Fault detection circuitry monitors battery, throttle connections, output transistors, bypass contactor, etc., to prevent runaway conditions

Static return to off (SRO) function requires that forward or reverse selectors be returned to neutral before output is allowed [optional feature]

Emergency reverse enhances plugging current when belly-buttonis activated on walkie-type applications [optional feature]

Delayed bypass (1A) output drives a bypass contactor [optional feature]

Forward, reverse, and bypass contactor driver outputs are internally protected against shorts in the contactor coils

Simple installation with no adjustments required

Tin-plated solid copper bus bars

Push-on connectors for control wiring

Familiarity with your Curtis PMC controller will help you to install and operate it properly. We encourage you to read this manual carefully. If you have questions, please contact the Curtis office nearest you.

CAUTION

Working on electric vehicles is potentially dangerous. You should protect yourself against runaways, high current arcs, and outgassing from lead acid batteries:

RUNAWAYS Some fault conditions could cause the vehicle to run out of control. Jack up the vehicle and get the drive wheels off the ground before attempting these procedures or any other work on the motor control circuitry.

HIGH CURRENT ARCS Electric vehicle batteries can supply very high power, and arcs can occur if they are short circuited. Always open the battery circuit before working on the motor control circuit. Wear safety glasses, and use properly insulated tools to prevent shorts.

LEAD ACID BATTERIES Charging or discharging generates hydrogen gas, which can build up in and around the batteries. Follow the battery manufacturer's safety recommendations. Wear safety glasses.

2

HARDWARE INSTALLATION

CONTROLLER

The controller can be oriented in any position, but the location should be carefully chosen to keep the controller as clean and dry as possible. If a clean, dry mounting location cannot be found, a cover must be used to deflect dirt and water splash.

The controller should be fastened with four screws to a clean, flat metal surface that provides an adequate heat sink. The mounting surface is an integral part of the overall heatsinking of the controller, and affects its ability to dissipate heat. The case outline and dimensions are shown in Figure 2 (1204X and 1205X controllers) and in Figure 3 (1209 and 1221 controllers).

Fig. 2 Mounting dimensions, Curtis PMC 1204X/5X controllers.

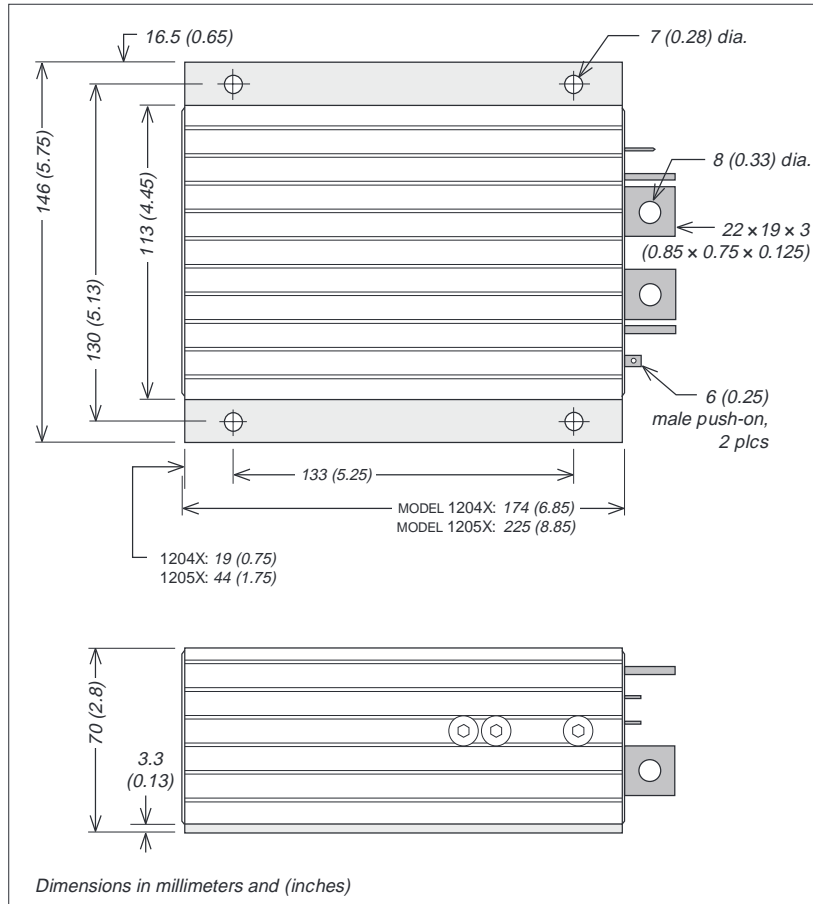

Be sure to mount the controller so as to allow access to the adjustment screws.

Although not usually necessary, a thermal joint compound can be used to improve heat conduction from the case to the mounting surface.

Fig. 3 Mounting dimensions, Curtis PMC 1209/21 controllers.

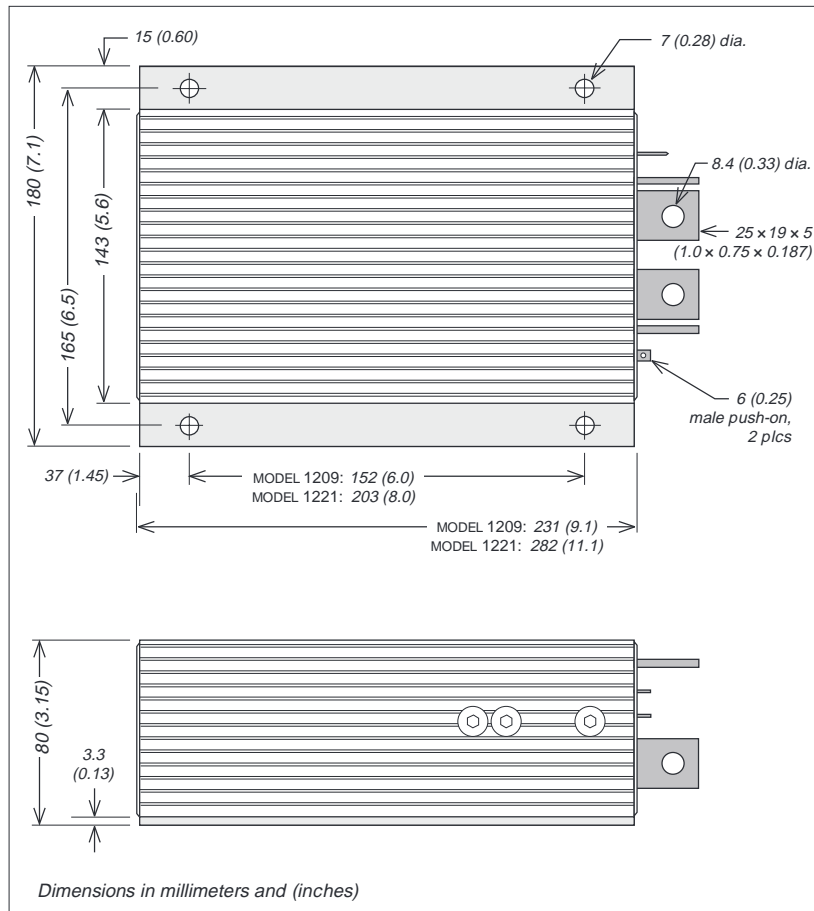

THROTTLE

0–5k Ω Input

The standard controller throttle input is 0–5k Ω . Curtis PMC potboxes (PB-5, -6, -9, -10) are designed to match this input. Some of these potboxes have a built-in microswitch, eliminating the need to install a separate pedal-actuated microswitch. Curtis PMC also offers a self-contained footpedal unit (FP-2) that eliminates the need for fabricating and installing a pedal-potbox linkage. Mounting dimensions for the potboxes and for the footpedal unit are shown in Figures 4 and 5.

Any potbox that provides a nominal 0–5k Ω output (controller output begins at \approx 300 ohms, full output is \approx 4400 ohms) will work with the standard throttle input. For other types, contact your Curtis office.

If a Curtis PMC potbox is used, it must be mounted so as to allow connection between the potbox lever arm and the vehicle accelerator linkage. The lever arm provides a series of holes so that the accelerator pedal "throw" can be converted into the correct amount of potentiometer rotation. Use of a second return spring on the pedal, in addition to the potbox return spring, is required to prevent an uncontrollable full-on throttle input (which could happen if there was a single spring, and it broke). If the self-contained potbox spring is insufficient to return the pedal by itself, two additional pedal return springs must be used.

It is also required that the accelerator pedal hit a mechanical stop at its full-on position just before (\approx 1 mm [1/32"–1/16"]) the potbox lever hits its own full-on stop. This mechanical stop will prevent the potbox lever arm from bending if undue force is put on the pedal. Protection of the potbox from water and dirt will help avoid problems of corrosion and electrical leakage.

After the potbox has been mounted, operation of the pot can be tested by measuring the resistance between the two wires with an ohmmeter. With the pedal not applied, the resistance should be less than 50 ohms. As the pedal is applied, the resistance should rise smoothly until it reaches a value between 4500 and 5500 ohms. Values below 4500 ohms may cause a reduction in efficiency and top speed. Values above 7000 ohms indicate a defective potbox, and will cause controller shutdown.

5k Ω –0 Input

The 1204X/1205X/1209/1221 controllers are also available with 5k Ω –0 throttle inputs. Using this throttle type, controller output begins at \approx 4400 ohms with full output at less than 300 ohms.

Fig. 4 Mounting dimensions, Curtis PMC potboxes PB-5, -6, -9, and -10.

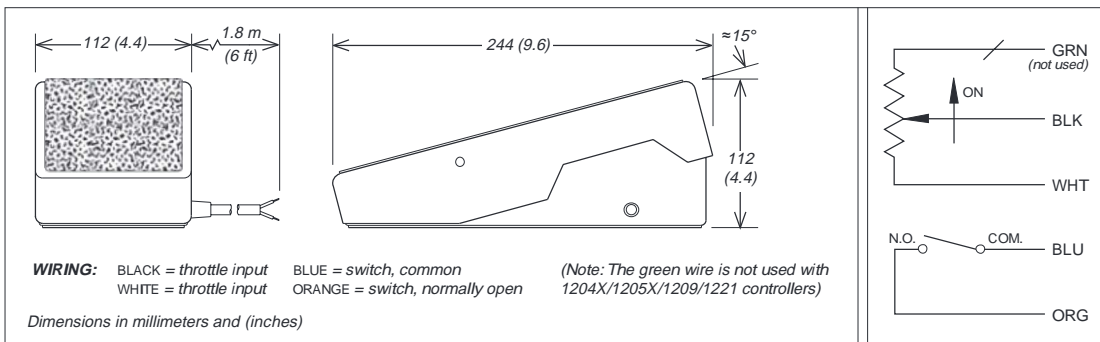
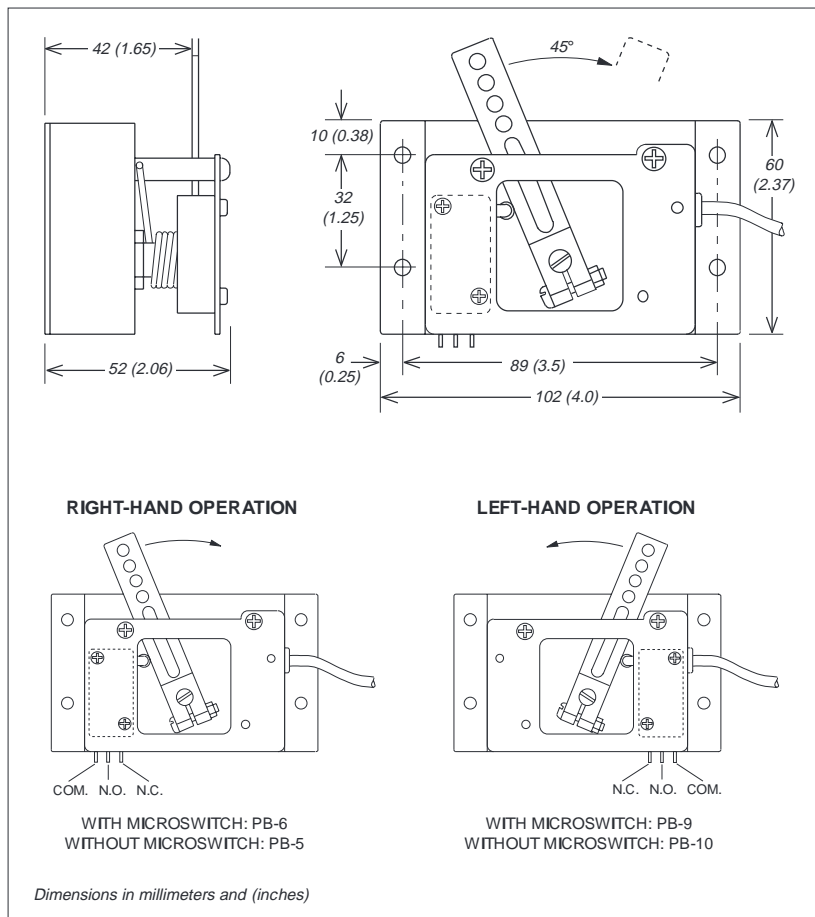

Fig. 5 Curtis PMC footpedal FP-2.

0–5V Input

A 0–5V throttle input option is also available for the 1204X/1205X/1209/1221 controllers. The negative side of the 5V source should be referenced to B- and must be capable of driving an input impedance of 5kΩ.

Curtis offers two bi-directional, wigwag electronic throttle assemblies designed for use with the 0–5V input: the ET series and the CH series.

The ET-XXX throttle assembly provides a 0–5V output and forward/reverse relay coil drivers. Dimensions for the ET-series electronic throttles are shown in Figure 6. The CH-XXX is a complete control head assembly, consisting of an ET-XXX throttle integrated into a molded steel and plastic assembly designed for mounting directly to a tiller stem. For more information about ET and CH products, contact your nearest Curtis office.

Fig. 6 Mounting dimensions, Curtis electronic throttle (ET series).

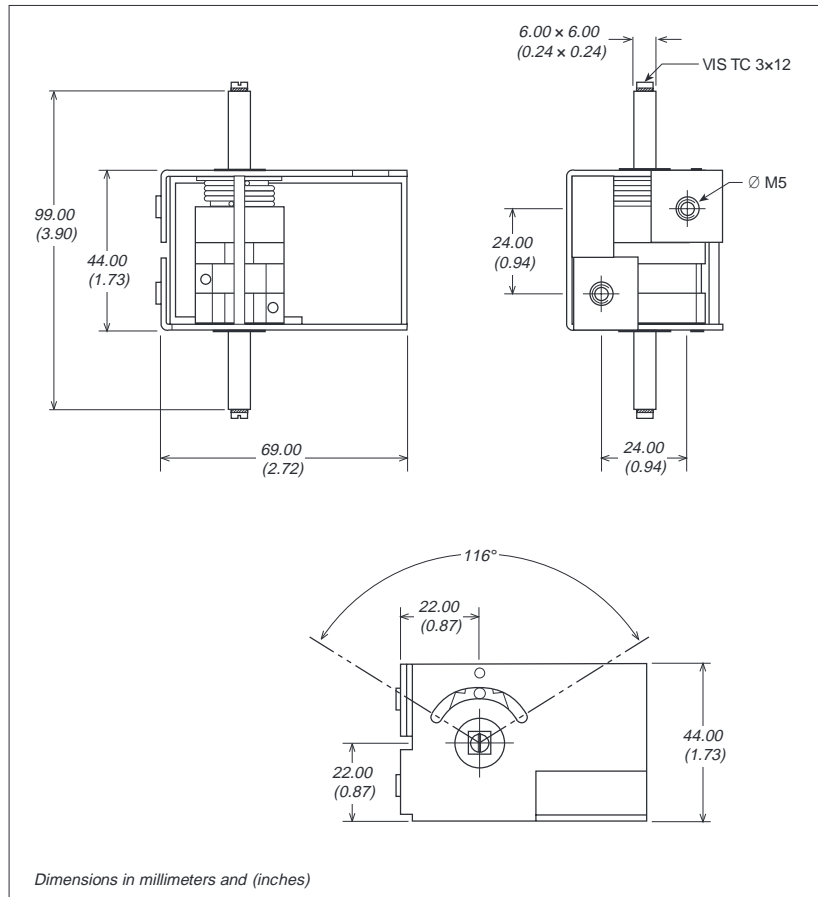

OTHER HARDWARE

The recommended hardware for a typical 1204X/1205X/1209/1221 controller installation is shown in Figure 7.

Contactors should be mounted in a clean, dry location. If such a location is unavailable, a cover should be used to deflect dirt and water splash.

The precharge resistor connected to the main contactor, and the coil suppression diodes connected to the main contactor and to the forward/reverse contactors, are somewhat delicate components. Care should be taken to prevent damage to them during installation.

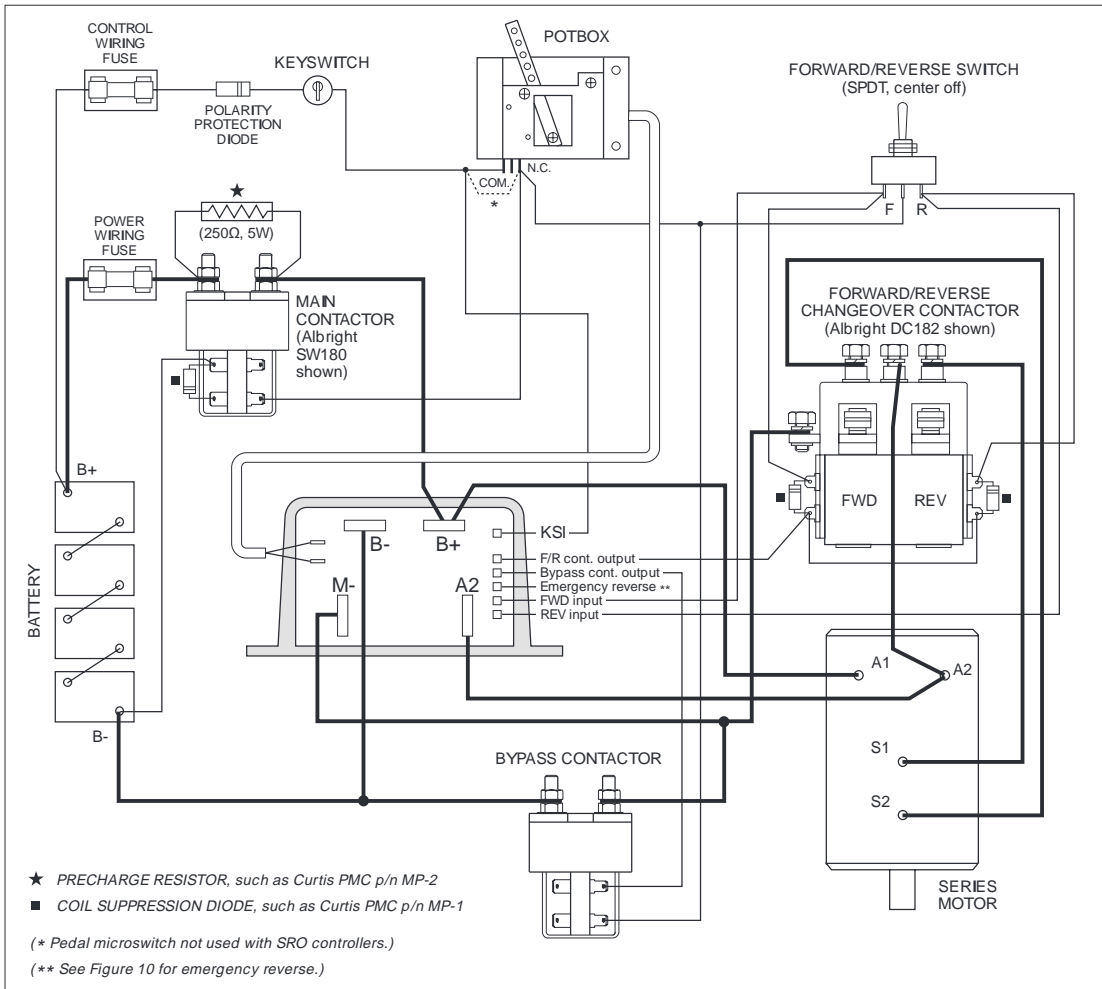

Fig. 7 Typical installation, Curtis PMC 1204X/1205X/1209/1221 controllers.

Main Contactor

Most applications use a main contactor in series with the battery positive (B+) cable to disconnect all power when the system is turned off, as shown in Figure 7. A heavy-duty single-pole, single-throw (SPST) contactor with silver-alloy contacts is recommended, such as an Albright SW80 or SW180 (available from Curtis).

A coil suppression diode, such as a Curtis PMC p/n MP-1 (which is rated at 100 volts, 3 amps), should be used on the contactor coil.

The rapid charging of the controller's internal filter capacitors causes a high inrush current to flow briefly when the contactor closes. To extend contact life, a precharge resistor, such as Curtis PMC's p/n MP-2 (rated at 250Ω, 5W), is recommended; the resistor precharges the capacitors and reduces the inrush current through the contacts. If an inexpensive can-type solenoid is used, the resistor is mandatory to prevent contact welding. For applications above 48V, a precharge resistor with a power rating greater than 5W is recommended.

Forward/Reverse Contactors

The forward/reverse contactor coils must match the vehicle's battery voltage. The maximum allowed coil current for each contactor is 1 amp. Use of a changeover contactor set such as the Albright DC88 or DC182 (available from Curtis) is recommended. Alternatively, two single-pole, double-throw (2×SPDT) contactors may be used. Although inexpensive can-type solenoids may be used, their ratings are typically not sufficient for long life.

A coil suppression diode, such as a Curtis PMC p/n MP-1 (which is rated at 100 volts, 3 amps) should be used on each of the forward/reverse contactor coils.

Forward/Reverse Switches

The forward/reverse contactor coils can be operated by any type of single-pole, double-throw (SPDT) center-off switch capable of switching the coil current. Toggle or rocker switches are generally used.

If your controller has the optional high pedal disable (HPD) feature and you plan to wire it for freewheeling, the best switch to use is a double-pole, double-throw (DPDT) hesitation switch or a toggle switch with a mechanism that forces it to stop in the center (neutral) position before going into the opposite direction. If a standard switch is moved quickly from one direction to the other, it may not be in neutral long enough to actuate HPD, and the motor will plug brake instead of freewheeling. The switch must be in neutral for several milliseconds to actuate HPD.

Bypass Contactor

A bypass contactor can be used with controllers that have the optional bypass contactor output feature. The bypass option is available only on 12V and 24–36V

controllers. (NOTE: A bypass contactor should not be used with controllers that do not have this feature, as the controller could be damaged when the system comes out of bypass mode.)

The bypass contactor must be able to carry and to interrupt the maximum motor current. A coil suppression diode should not be used on this contactor. Refer to the controller specifications in Appendix C to determine the contact current requirement for the bypass contactor. The maximum allowed coil current for this contactor is 1 amp.

Emergency Reverse Relay

A small double-pole, double-throw relay must be installed to implement emergency reverse. Its contact rating must be adequate to switch the current needed by the forward/reverse contactor coils.

Keyswitch and Interlocks

The vehicle should have a master on/off switch to turn the system off when not in use. A keyswitch is typically used for this purpose.

An interlock device is necessary for implementation of SRO. With the SRO option, the vehicle cannot be started or operated without the designated SRO interlock activated.

Various other safety and convenience interlocks may also be used to prevent motor operation during certain conditions. For example, a battery charger interlock can be used to prevent operation during charging. Similarly, a seat switch can be used to turn the vehicle off when the operator gets up from the driver's seat. The contacts of these switches should be rated for the total coil currents of all the contactors they operate.

Polarity Protection Diode

For polarity protection, a diode should be added to the control circuit. This diode must be sized appropriately for the maximum total contactor coil currents.

Control Wiring Fuse

To protect the control circuitry from accidental shorts, a small fuse (typically 10 amps) connected in series with the B+ feed to the control circuitry wiring is recommended.

Power Wiring Fuse

To protect the power wiring circuit, a fuse appropriate for the controller's rated current (see Appendix C) is recommended.

3

WIRING

CONNECTIONS: Low Current

Two 1/4" push-on terminals are provided for the throttle inputs. If your controller has a voltage throttle input, there will be only one throttle terminal.

A 6-pin low power connector molded into the right side of the controller face provides the low power logic control connections: KSI input, forward/reverse contactor output, bypass contactor output (optional), emergency reverse input (optional), and forward and reverse inputs.

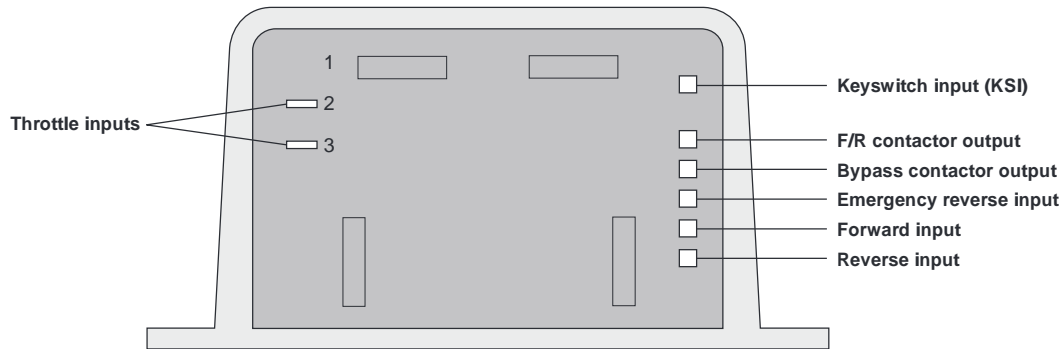

Several manufacturers make mating connectors that fit this connector. The part numbers listed are for the recommended 0.75 mm² (#18 AWG) vinyl insulated stranded wire.

MFR	PART NUMBER	DESCRIPTION
AMP	#640426-7	locking, insulation displacement terminals, wires at right angle to connector
Method	#3300-107-218	locking, insulation displacement terminals
Molex	#09-50-3071	locking, crimp terminals
Panduit	#CE156F18-7	locking, insulation displacement terminals, wires at right angle to connector

CONNECTIONS: High Current

Four tin-plated solid copper bus bars are provided for the high current connections to the battery and motor.

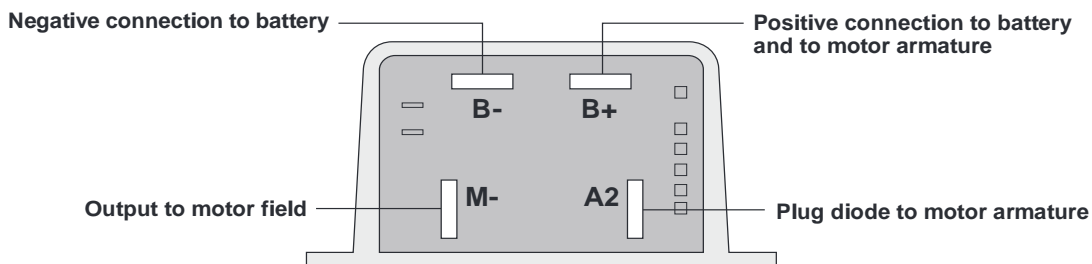

The cables used for the battery and motor connections must be heavy enough to carry the high current required. Rubber insulated welding cable is convenient to work with because of its flexibility.

Connections to the controller bus bars should be made with lugs suitable for the cable used, fastened by M8 (5/16") bolts and nuts. When tightening the bolts, two opposing wrenches should be used. Failure to use the double-wrench technique could cause undue strain to be placed on the internal connections, and could also result in cracked seals around the bus bars.

WIRING: TYPICAL INSTALLATION

Curtis PMC 1204X/1205X/1209/1221 controllers are designed to satisfy the requirements of material handling applications using series motors. Figure 8 is a schematic diagram of the installation shown in Figure 7. Wired this way, the vehicle will plug brake if the direction is changed with the vehicle moving and the throttle applied. Reversing is accomplished via a forward/reverse changeover contactor or two single-pole, double-throw (2×SPDT) contactors. Coil suppression diodes should be used on the main and forward/reverse contactors.

KSI Wiring

The keyswitch input (KSI) circuit includes inputs from the keyswitch and from the various interlocks. The controller KSI is used to turn the controller on and off. KSI is turned on by connecting it to battery B+. Any positive voltage greater than about 8 volts will turn on the controller, but usually the full vehicle battery voltage is used.

In its simplest form, KSI is operated by a keyswitch that turns the vehicle off and prevents unauthorized use. The keyswitch should also turn off the main

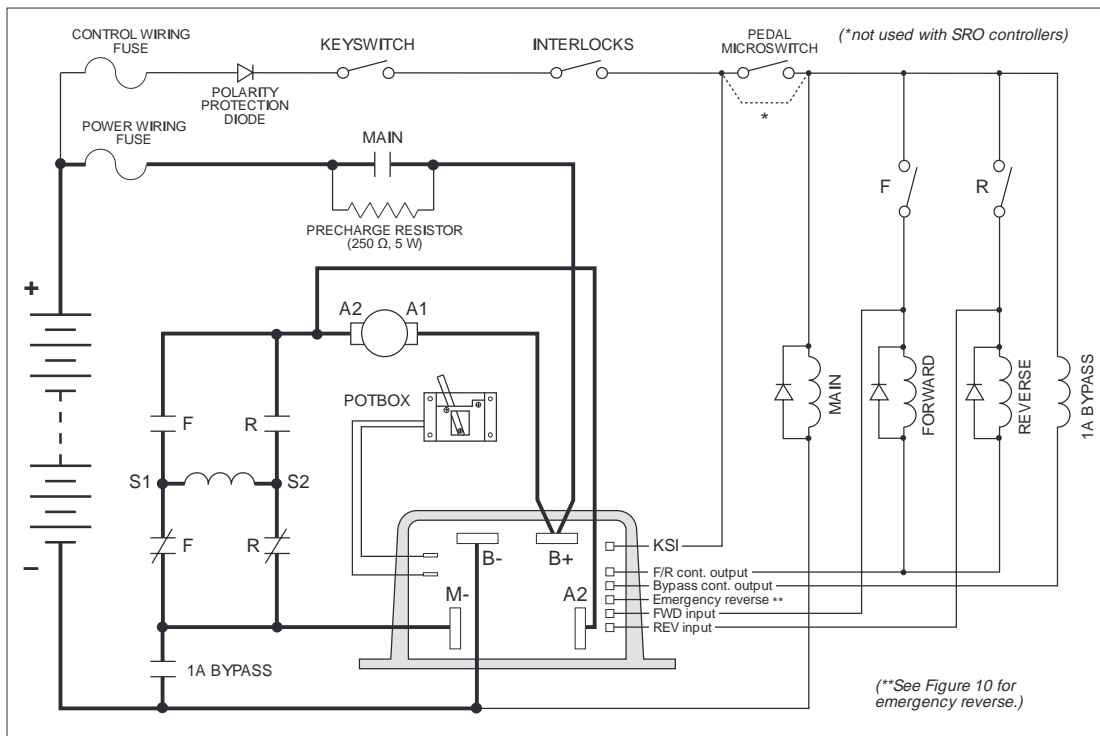

Fig. 8 Basic wiring configuration, Curtis PMC 1204X/1205X/1209/1221 controllers.

contactor and the forward/reverse contactors. This will act as a safety feature by removing power from the motor control system when the keyswitch is off.

Interlocks (seat switches, battery charger interlocks, etc.) should be wired in series so that they turn off the controller KSI and the contactors. An SRO interlock (a seat switch, for example) must be wired in order to implement the optional SRO feature.

Forward/Reverse Wiring

The forward/reverse wiring schemes described here all assume the power wiring shown by the heavy lines in Figure 8. Some vehicles, especially those previously using older, resistor-type controllers, may reverse the motor armature rather than the field winding. Be careful if you are replacing this type of controller. When using the Curtis PMC controller it is essential that the field be reversed and that the armature be connected directly to the controller's B+ and A2 terminals, because the plug diode inside is connected to these terminals.

Plug Braking

The standard forward/reverse control wiring (as shown in Figure 8 by the thin lines) provides plug braking. The forward/reverse switch should be in the positive feed to the contactor coils, so that they can be turned off by the keyswitch, interlocks, and pedal microswitch. The coil of one contactor or the other is energized to select the direction desired. The contactor coils should have suppression diodes connected across them to improve switch contact life.

Freewheeling: Wiring to Inhibit Plug Braking

If a non-SRO controller has the HPD option, this feature can be used to inhibit plug braking by briefly turning off the controller's KSI input when the forward/reverse switch goes through neutral. As shown in Figure 9, another set of contacts is added on the forward/reverse switch. Therefore, a double-pole, double-throw (DPDT) center-off switch must be used for this setup. A hesitation switch is recommended, to ensure the switch is in neutral long enough to actuate HPD and inhibit plug braking.

Fig. 9 Control wiring for inhibiting plug braking in order to allow freewheeling.

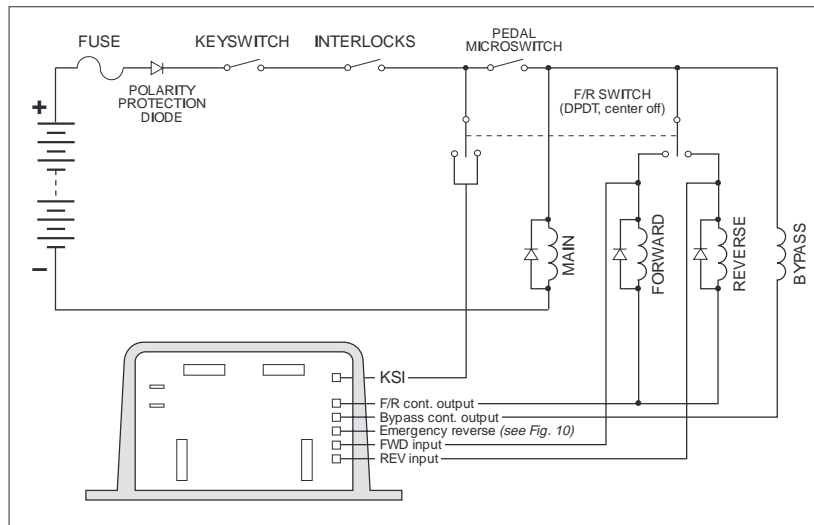

Plug braking can be reactivated during freewheeling by releasing the throttle and reapplying it.

NOTE: Contact factory for information on wiring SRO controllers for freewheeling.

Throttle Pot Wiring

Standard Potbox Wiring

If the throttle input to the controller is from a Curtis PMC potbox or footpedal, the wiring is simple: just connect the two wires of the potbox/footpedal cable to the two push-on terminals of the controller, as shown in Figure 8. It doesn't matter which wire goes on which terminal. The wires can be extended as required.

IMPORTANT: All vehicles with non-SRO controllers should have pedal-actuated microswitches to protect against runaways in the event the forward/reverse switch becomes stuck in either direction. If your potbox doesn't have such a microswitch built in, you should add one.

Any suitable potentiometer of 5 k Ω nominal resistance will work with the standard throttle input of the 1204X/1205X and 1209/1221 controllers. As shown in Figure 11, connection should be made to the wiper and to one outer terminal of the pot so that resistance increases as the throttle is applied.

Fig. 11 Standard throttle pot, 0–5k Ω .

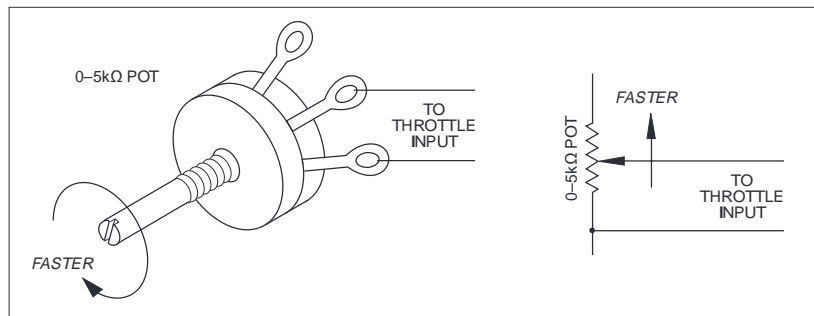

Pots for Twist-Grip Throttles

Twist grip throttles either twist in only one direction (and are used only for acceleration), or they twist both ways (and are also used for reversing, by means of microswitches that select a direction contactor). For twist grips that twist in only one direction, the controller throttle input can be from a 5 k Ω pot as shown above in Figure 11.

For twist grips that twist both ways, a pot capable of going from zero in neutral to 5 k Ω in each direction can be used. A mechanism can be designed to

Fig. 12 Bi-directional twist-grip throttle with 10 k Ω center-tapped, 4-terminal pot.

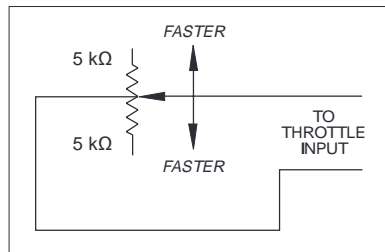

make a standard pot turn in the same direction regardless of which direction the twist grip is turned. Alternatively, a 4-terminal, center-tapped 10 k Ω pot can be coupled directly to the twist grip, as shown in Figure 12.

A third method of accommodating bi-directional twist grip throttles uses a standard potentiometer and a controller with a nonstandard throttle input. As shown in Figure 13, a standard 20 kΩ pot is used, with its end terminals wired together.

Fig. 13 Bi-directional twist-grip throttle with a standard 20 kΩ pot and a controller with the optional 5kΩ throttle input.

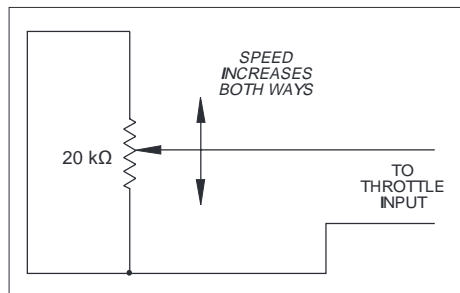

The resistance goes from 5 kΩ at neutral to zero at the extremes—the opposite of the standard throttle input configuration. Contact the factory if you need this type of controller.

WARNING: with the input circuit shown in Figure 13, potentiometer or wiring open circuits turn off the controller's output. However, pot wiring shorts appear the same as a normal zero ohm signal to the controller, and will produce full speed operation if the short occurs while the power is on.

Reduced Speed Operation

Vehicle top speed can be easily limited, for safety or other reasons. A single resistor connected in parallel with the throttle pot will reduce maximum speed according to its resistance value, as shown in Figure 14. Use of a variable resistor makes adjustment of maximum speed easier. With a switch, speed can be limited in reverse only, or the speed reduction can be switched off—for example, to allow authorized personnel to run the vehicle outdoors at full speed.

Fig. 14 Reduced speed operation (with standard 0–5kΩ pot).

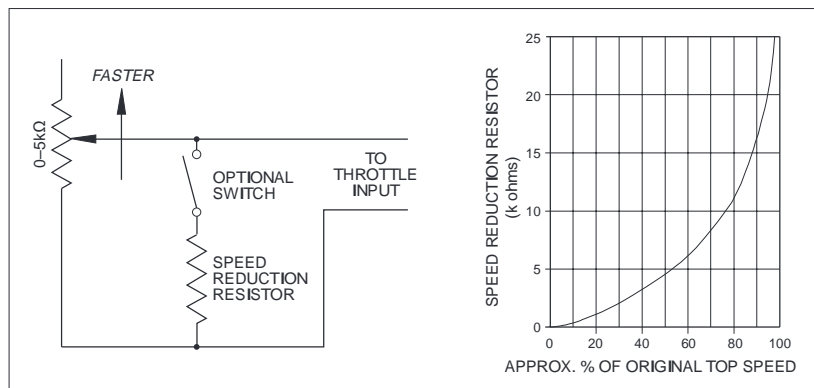

The speed reduction shown in the curve is approximate. The actual vehicle top speed will depend on the motor characteristics and the vehicle load. You

should determine by experiment the proper resistor value to give the desired speed reduction. (NOTE: with reduced speed operation, only top speed is reduced; full power is maintained for starting at low speeds.)

Unlike resistor controllers, Curtis PMC controllers operate efficiently in the reduced speed mode, because little power is lost through the controller.

Electronic Throttle Wiring

Curtis's electronic throttle, ET-XXX, is wired as shown in Figure 15. It requires a controller with the optional 0.5V throttle input.

Fig. 15 Curtis electronic throttle (ET series) with a controller having the optional 0.5V throttle input.

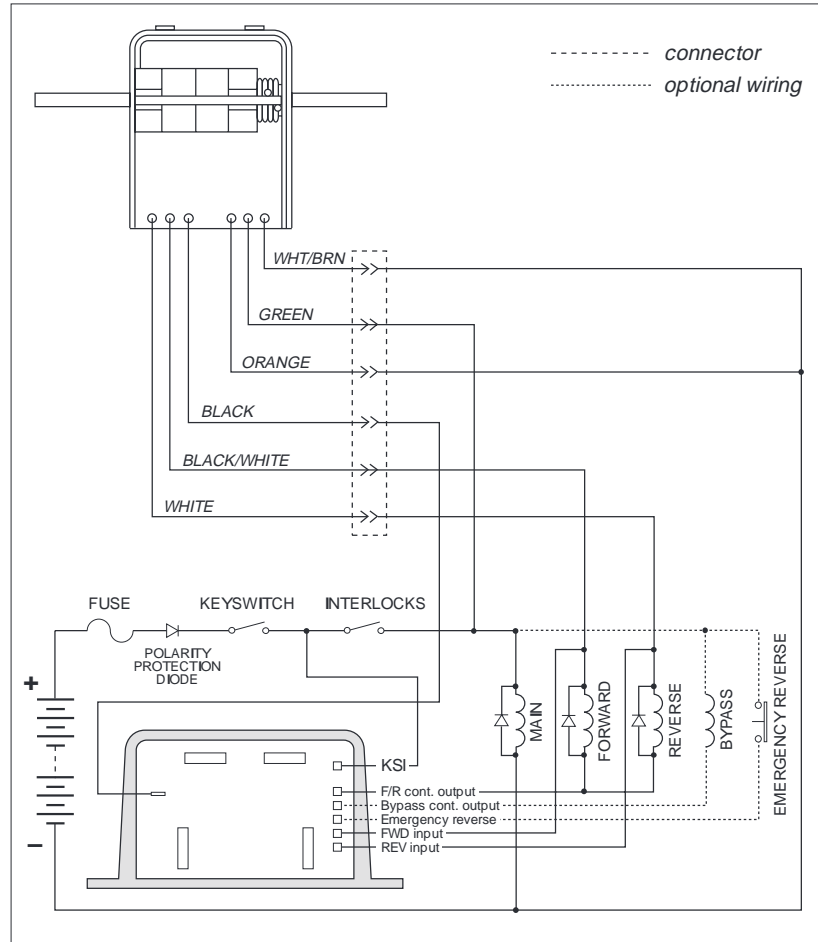

Bypass Wiring

If you are using a potbox, wire the control and power circuits for the bypass contactor as shown in Figure 8. If you are using an ET-series electronic throttle, the power circuit is the same; wire the control circuit as shown in Figure 15.

Note that a suppression diode is not used with the bypass contactor coil because it would slow the turn-off of the contactor with the possible result of a false fault being detected. Bypass contactors should be used only with controllers that have the optional bypass feature. The bypass option is available only on 12V and 24□36V controllers.

WIRING: PM MOTORS

Because of their M- fault detect circuitry, 1204X/1205X/1209/1221 controllers are not compatible with permanent magnet (PM) motor applications. During deceleration, the PM motor would act as a generator, holding the M- terminal low. As the throttle demand is less than 80%, the controller would interpret this as a fault and would shut itself off. The keyswitch would then need to be recycled before the controller could operate. Another problem is that plug braking could not be used without adding external circuitry. These controllers are not recommended for use with PM magnet motor systems. Consult your Curtis office for controllers compatible with PM motors.

INSTALLATION CHECKOUT

Carefully complete the following checkout procedure before operating the vehicle. If a step does not test correctly, use the troubleshooting guide (Section 5) to identify the problem.

CAUTION

Put the vehicle up on blocks to get the drive wheels off the ground before beginning these tests.

Don't let anyone stand in front of or behind the vehicle during the checkout.

Make sure the keyswitch is off and the vehicle is in neutral before beginning.

Wear safety glasses and use well-insulated tools.

- A. Connect the battery. Use a voltmeter to verify that the proper voltage and polarity appears at the battery B+ and B- terminals.
- B. Check the voltage at the controller B+ and B- bus bars. If your system has a precharge resistor in parallel with the main contactor, you should see approximately 90% of full battery voltage. If your system does not have a resistor, connect one temporarily (100 to 200 ohms, 5 watts, or a 100 watt light bulb). The voltage at the controller should rise to approximately 90% of full battery voltage.
- C. If A and B do not check out, troubleshoot the wiring connections. Do not proceed until the trouble is corrected and A and B check out.
- D. With the forward/reverse switch in neutral, turn on the keyswitch. If the motor runs without the throttle being applied, turn the keyswitch off and recheck the wiring. If the motor does not run without the throttle applied, proceed with the checkout.
- E. Select a direction and slowly apply the throttle; the motor should now respond. Look to see which direction the wheels are turning. If the wheels are going the wrong way, turn everything off and interchange the motor field connections.
- F. If you have HPD, check it next. Turn off the keyswitch and direction switch. Apply the throttle, turn the keyswitch on, and then select a direction. The motor should not run. Release the throttle and re-apply it the motor should now run. If the motor runs before you release the throttle, recheck the wiring.

-
- G. If you have SRO, check it out similarly. Turn off the SRO interlock. Place the direction switch in forward, turn the interlock back on, and apply the throttle. The motor should not run. If the motor runs, recheck the wiring. Repeat this test, selecting reverse before turning on the SRO interlock.
- H. Take the vehicle down off the blocks and drive it in a clear area. It should have smooth acceleration and good top speed.
- I. On vehicles that are intended to plug brake, test the plug braking by driving forward at moderate speed and shifting into reverse without letting up on the throttle. The vehicle should smoothly brake to a stop and accelerate in reverse.
- J. On vehicles that are intended to have plug braking inhibited, verify that the maneuver in □□ produces freewheel coasting.
- K. Finally, check your emergency reverse. If your vehicle uses a belly-button emergency reverse switch to enhance plug braking current, depress the button while the vehicle is moving forward (toward the operator). The vehicle should stop quickly (more quickly than in Step □□) and accelerate in reverse at full speed as long as the belly button is depressed. If the belly button is pushed while the vehicle is moving backwards (away from the operator), the vehicle will accelerate to full speed but will not change direction.

4

MAINTENANCE & ADJUSTMENT

Curtis PMC 1204X/1205X/1209/1221 controllers and potboxes require only minimal maintenance if properly installed. **NOTE:** The controllers are sealed and thus are not field serviceable.

CONTROLLERMaintenance**CAUTION**

It is recommended that the following two steps be performed occasionally. First remove power by disconnecting the battery, and discharge the capacitors in the controller (with a light bulb or a 200 Ω, 25 W resistor connected for a few seconds across B+, B-). Follow good safety practices: get the vehicle drive wheels off the ground, wear safety glasses, and use insulated tools (see page 2).

1. Make sure the electrical connections to the controller (and to the motor, contactors, etc.) are tight. When checking the controller bus bar connections for tightness, use two opposing wrenches. This double-wrench technique will help avoid putting stress on the bus bars, which could crack the seals. Always use insulated wrenches.
2. Inspect all seals at the front and back of the controller. If necessary, use a moist rag to wipe these areas clean enough so that you can see the seals. Look for cracks and other signs of seal damage.

If the seals are intact, clean the controller thoroughly either by washing it off or by wiping it clean with a moist rag. Power must not be reapplied until the controller terminal area is completely dry.

If the seals have been damaged, there are several possible causes. Perhaps the double-wrench technique was not used when the cables were installed. Perhaps the vehicle's environment requires that the controller be better protected: either by mounting it in a different location, or by installing a protective cover.

Damaged seals can lead to faulty operation. We strongly recommend replacing controllers that have faulty seals.

Adjustment

Some controllers allow adjustment of the plug braking current, current limit, and acceleration rate settings. The adjustment pots on these models are located as shown in Figure 16.

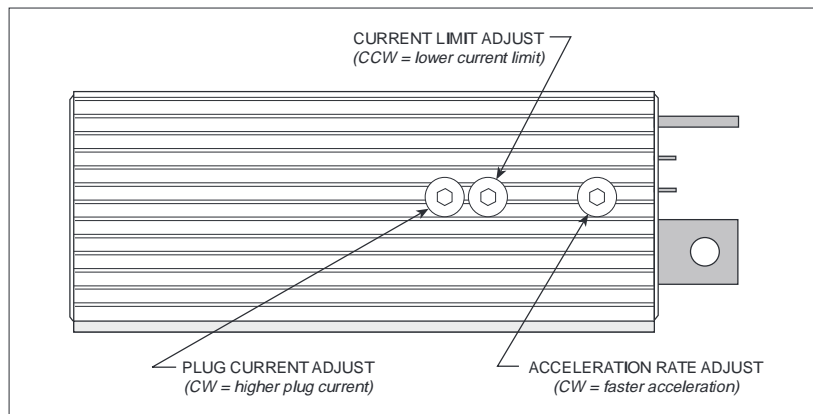
Fig. 16 Adjustment pots.

Use the following adjustment procedure. The keyswitch should be off during adjustment.

1. Remove the socket head screw (1/8" Allen) for the adjustment you want to make.
2. Adjust the internal potentiometer using a small insulated screwdriver (available from Curtis).
3. Replace the socket head screw and nylon seal washer. To prevent stripping, do not over-tighten.

POTBOX

Maintenance

Potbox maintenance is similar to controller maintenance: inspect for integrity of connections and mounting, and clean (with a moist rag) as required.

Adjustment

Curtis PMC potboxes are factory set and rarely require user attention. To test and adjust, connect an ohmmeter to the potbox wires and use this procedure:

1. With the spring holding the lever arm against the return stop, the resistance should be less than 50 ohms. Slowly move the lever. If the resistance abruptly starts to increase when the lever is 3 mm (1/8") from the stop (1.5 mm [1/16"] for potboxes without the microswitch), no adjustment is needed.

2. If adjustment is required, loosen the screw holding the lever on the pot shaft. Use a screwdriver to rotate the pot shaft slightly with respect to the lever. Recheck the point at which the resistance starts to increase and continue making adjustments until the increase starts at 3 mm (1/8") [at 1.5 mm (1/16") for potboxes without the microswitch]. When adjustment is correct, tighten the screw holding the lever on the pot shaft, then recheck to see that this action did not disturb the adjustment. Make sure that the lever is still seated down on the pot shaft below the slight bevel on the end of the shaft.
3. Check the resistance with the lever pushed all the way to the other stop. It should be between 4500 and 5500 ohms. If it is outside this range, the potbox is faulty and should be replaced.
4. For potboxes equipped with a microswitch, check for correct switch operation. Use an ohmmeter, or simply listen for the slight click the switch makes. It should operate when the lever is 1.5 mm (1/16") from the return stop. If it does not, adjust by loosening the two screws holding the slotted microswitch mounting plate to the stop spacers and moving the plate. Recheck the switch operating point after tightening the screws.

5

TROUBLESHOOTING AND BENCH TESTING

Some behaviors that may seem to suggest controller malfunction do not, in fact, indicate a problem but rather are typical of normal operation. Before undertaking the diagnostic tests, check to see whether your problem is addressed in the [First section](#), [Operational Notes](#).

The diagnostic tests are designed to enable you to determine whether the trouble is in the controller or in some other part of the motor control circuitry. The controllers themselves are sealed and not field serviceable; contact your local Curtis PMC service center if the problem is in the controller. The diagnostic section provides enough detail to enable you to track circuitry problems to their source and repair them.

Finally, the bench tests will allow you to confirm controller operation in a simple, low-power test configuration. Bench testing is primarily intended for checking out a number of controllers on a regular basis.

OPERATIONAL NOTES

Noise

Controller operation is normally silent, with two exceptions. A 1 kHz tone may be heard during plug braking. This noise is normal and indicates that plugging is taking place. The noise will stop when plug braking stops.

The same noise may indicate overtemperature. The controller shifts frequency during overtemperature from its normal 15 kHz to 1 kHz, providing an audible tone to alert the operator to the overtemperature condition.

Inability of Vehicle to Plug Brake to a Stop on a Steep Ramp

If the vehicle is rolling backwards down a steep ramp in reverse and the throttle is applied demanding forward drive, the controller will attempt to plug the vehicle to a stop. If the ramp is so steep that the plugging current setpoint is insufficient to stop the vehicle, it will continue to be braked but will nevertheless roll down the ramp. If the mechanical brakes are applied, and the vehicle is stopped, the full drive current will be available when the throttle is applied and the vehicle will proceed up the ramp.

Sluggish Vehicle Behavior

Loss of power will be noticeable when the batteries become overly discharged. This is a normal response to low battery voltage. Curtis PMC 1204X/1205X/1209/1221 controllers are designed to protect against damage caused by low

batteries. On 24–36 volt models, power to the motor is cut back when the voltage goes below 16 volts. Refer to the specifications (Appendix C) for other models.

Hot Controller

If the controller gets hot, it does not necessarily indicate a serious problem. Curtis PMC 1204X/1205X/1209/1221 controllers protect themselves by reducing power to the motor if their internal temperature exceeds 75°C (167°F). Power output will be reduced for as long as the overheat condition remains, and full power will return when the unit cools.

In typical applications, overheating will rarely be a problem. However, vehicle overloading may cause overheating, particularly if the controller is mounted so that heat cannot be conducted away from its case or if other heat-generating devices are nearby. If thermal cutback occurs often during normal operation, the controller is probably undersized and should be replaced with a higher current model.

IN-VEHICLE DIAGNOSTIC TESTS (TROUBLESHOOTING)

These tests require a general purpose volt ohmmeter. You can use either a conventional V-O-M or an inexpensive digital voltmeter.

The troubleshooting chart (opposite) serves as a guide to the procedures that follow. Before starting these tests, refer to the appropriate wiring diagrams and make sure your controller is hooked up properly.

CAUTION

Working on electric vehicles is potentially dangerous. You should protect yourself while performing the diagnostic tests by jacking up the vehicle to get the drive wheels off the ground, opening the battery circuit before working on the motor control circuit, wearing safety glasses, and using properly insulated tools (see page 2).

Fig. 17 Guide to troubleshooting procedures. [To use this guide, refer to the specified PROCEDURES that follow.]

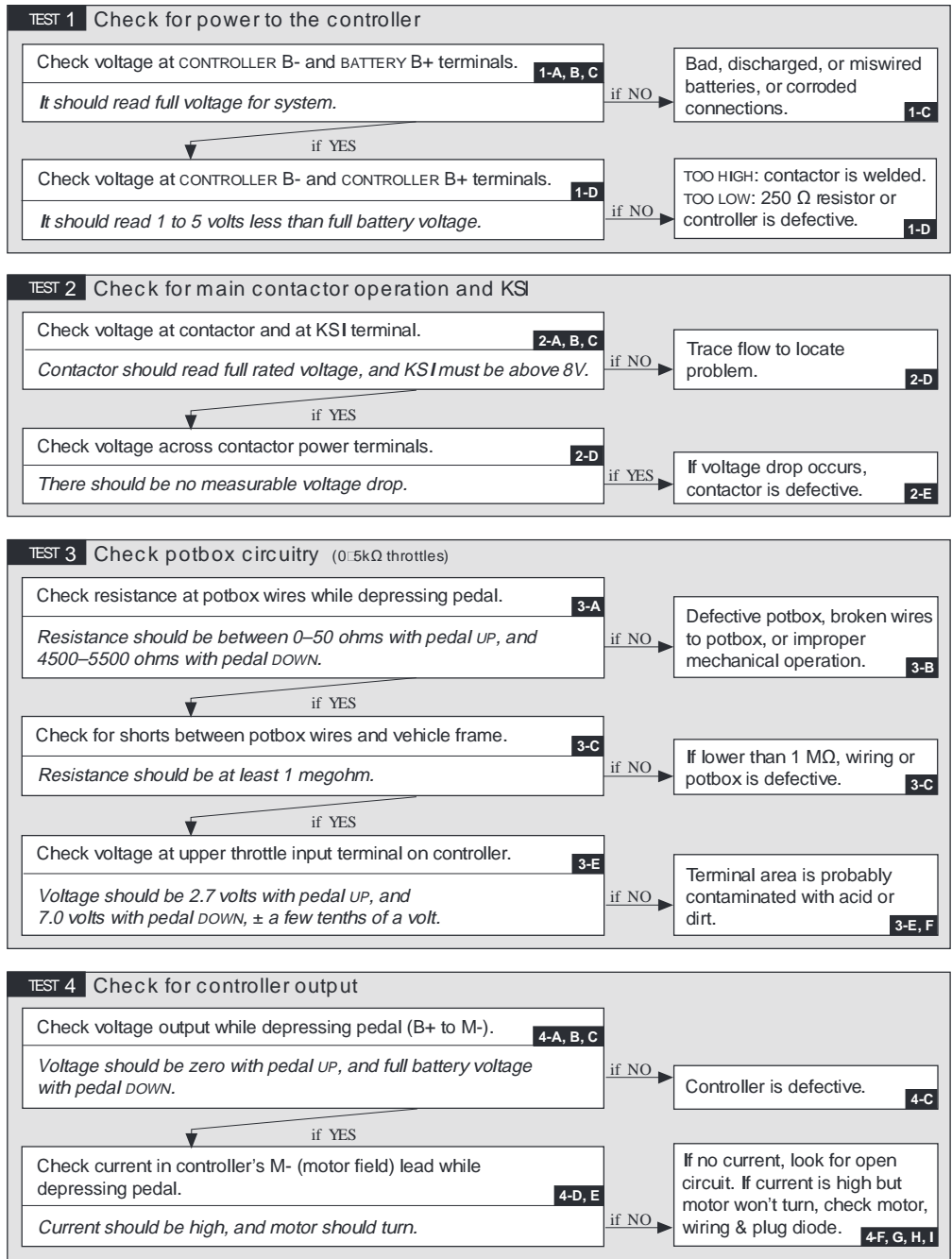

TEST 1 Check for power to the controller

- 1-A** Leave the keyswitch off for these tests.
- 1-B** Verify that battery (-) connects to the B- terminal of the controller. Connect voltmeter (-) lead to this point.
- 1-C** Connect voltmeter (+) to the battery side of the main contactor. Check for full battery voltage. If it is not there, the trouble is in the battery pack, the cables to it, or the power fuse.
- 1-D** Connect the voltmeter (+) lead to the controller B+ terminal. You should read a voltage 1 to 5 volts less than the full battery voltage. If this voltage is zero or close to zero, the trouble is either a bad controller, a bad 250 Ω resistor across the contactor, or an incorrectly connected cable between the contactor and the controller. Trace the cable to make sure it is hooked up right. Remove and test the 250 Ω resistor with an ohmmeter. If these check out, the controller is malfunctioning. If you see full battery voltage at this point, then the contactor has welded and must be replaced.

TEST 2 Check for main contactor operation and KSI

- 2-A** Turn the key on, place the forward/reverse switch in forward or reverse, and depress the footpedal until its microswitch operates. (In these procedures, we assume the footpedal is equipped with the recommended microswitch.)
- 2-B** This should cause the main contactor to operate with an audible click. Connect the voltmeter across the contactor coil terminals. You should see full battery voltage (minus the polarity diode drop).
- 2-C** The controller KSI terminal should also be getting full battery voltage. Verify this by connecting the voltmeter (-) to the controller's B- terminal, and the voltmeter (+) to the controller's KSI terminal.
- 2-D** If the contactor and KSI terminal are not getting voltage, that's the problem. Use the voltmeter to find out where it is not getting through. Connect the voltmeter (-) to the controller's B- terminal and check the following points with the voltmeter (+) lead to trace the flow:

1. First, check both sides of the control wiring fuse.
2. Check both sides of the polarity protection diode to make sure its polarity is correct.
3. Check both sides of the keyswitch.
3. Check both sides of the pedal microswitch.
4. Finally, check the contactor coil and controller KSI.

2-E If the contactor coil and KSI are getting voltage, make sure the contactor is really working by connecting the voltmeter across its contacts (the big terminals). There should be no measurable voltage drop. If you see a drop, the contactor is defective. (We assume the recommended precharge resistor is in place.)

TEST 3 Check the potbox circuitry

The following procedure applies to the standard throttle input configuration for these controllers, which is a nominal 5k Ω pot connected as a two-wire rheostat (0 = full off, 5 k Ω = full on), and also to 5k Ω \square 0 configurations. If your installation uses a controller with a throttle input other than 0 \square 5k Ω or 5k Ω \square 0, find out what its range is and use a procedure comparable to the one below to make sure your pedal/potbox is working correctly.

3-A With the keyswitch off, pull off the connectors going to the throttle input of the controller. Connect an ohmmeter to the two wires going to the potbox and measure the resistance as you move the pedal up and down. The resistance at the limits should be within these ranges:

	RESISTANCE (in ohms)	
	STANDARD	
	0 \square 5k Ω POT	5k Ω \square 0 POT
Pedal up:	0 \square 50	4500 \square 5500
Pedal down:	4500 \square 5500	0 \square 50

3-B If these resistances are wrong, it is because the pot itself is faulty, the wires to the pot are broken, or the pedal and its linkage are not moving the potbox lever through its proper travel. Actuate the pedal and verify that the potbox lever moves from contacting the pedal-up stop to nearly contacting the pedal-down stop. If the mechanical operation looks okay, replace the potbox.

- 3-C** While you have the potbox wires off the controller, use an ohmmeter to check for shorts between these wires and the vehicle frame. You should see a resistance of at least 1 megohm. If it is lower than that, inspect the wiring for damaged insulation or contact with acid. If necessary, replace the potbox.
- 3-D** Push the wires back on the controller terminals. It doesn't matter which wire goes on which terminal.
- 3-E** Inspect the terminal area of the controller closely. Occasionally a buildup of dirt or acid residue of a conductive nature causes electrical leakage between the throttle input terminals and the B- or M- terminals, leading to faulty controller operation. To check for this problem, measure the voltage at the appropriate throttle input terminal (the upper terminal for 0–5k Ω pots, the lower terminal for 5k Ω –0 pots), by connecting the voltmeter (-) lead to the controller's B- terminal. The keyswitch must be on and a direction selected for this test.

	THROTTLE INPUT VOLTAGE (in volts)	
	STANDARD	
	0–5k Ω POT UPPER TERMINAL	5k Ω –0 POT LOWER TERMINAL
Pedal up:	2.7	3.1
Pedal down:	7.0	7.4

Compare your readings with these; if they are different by more than a few tenths of a volt, contamination is probably the cause.

- 3-F** Carefully clean off the terminal area of the controller with a cotton swab or clean rag moistened with water, and dry thoroughly.

CAUTION

Be sure to turn everything off before cleaning.

Now test the controller to see if proper operation is restored. If so, take steps to prevent this from happening again: dirt and water must be kept from reaching the terminal area of the controller. If the voltages are still out of range, the controller is at fault and should be replaced.

TEST 4 Check for controller output

- 4-A** The first step is to measure the output drive voltage to the motor at the controller's M- terminal.
- 4-B** Connect the voltmeter (+) lead to the controller's B+ terminal. Connect the voltmeter (-) lead to the controller's M- terminal.
- 4-C** Turn on the keyswitch with the forward/reverse switch in neutral, and then select a direction and watch the voltmeter as you depress the pedal. The voltmeter should read zero (or close to zero) before you apply the pedal, and should read full battery voltage with the pedal fully depressed. If it does not, the controller is defective and must be replaced.
- 4-D** The next step is to measure the current in the controller's M- lead. If you have a means of measuring this high dc current, such as a shunt/meter setup or a clamp-on dc ammeter, use it. If not, we recommend that you buy an inexpensive ammeter of the type that is simply held against the wire being tested. These are readily available at auto parts stores, and their accuracy is adequate for this test.
- 4-E** Turn on the keyswitch with the forward/reverse switch in neutral, and then select a direction and watch the ammeter while depressing the pedal.
- 4-F** If you see no current flowing in the M- lead, the problem is an open circuit in the motor or the wiring between the motor and the controller. Check the forward/reverse switch. If your vehicle uses contactors for reversing, check to see that they are operating and that their contacts are closing. If these are okay, check the motor armature and field for opens.
- 4-G** If you do see a high current flowing in the M- lead, but the motor does not turn, the problem is a short in the motor circuit, a miswired motor, or a short in the controller's internal plug diode. Test the plug diode as follows:
1. Remove power by opening the battery circuit. Take the cable off the controller's A2 terminal.
 2. Use an ohmmeter to check the resistance between the controller's A2 and B+ terminals. You are testing for the presence of a diode inside the controller, so swap the two leads of the ohmmeter and look for a low resistance one way and a much higher one the other way. If your meter has a diode test function, use it.

3. If you find the diode to be shorted, the controller is defective.

4-H Put the A2 cable back on the controller and reconnect the battery.

4-I If the plug diode is okay, there is a short in the motor circuit. The short could be in the forward/reverse switch, so look there first. Because the resistance of the motor is so low, the motor must be tested separately if it is suspected of having a shorted winding.

BENCH TESTING

First, before starting any bench testing, pick up the controller and shake it. If anything rattles around inside, the unit should be returned.

CAUTION

Protect yourself during bench testing. Wear safety glasses and use insulated tools.

Equipment Needed

The simple setup shown in Figure 18 is required for testing these controllers on the bench. You will need:

- a POWER SUPPLY with a voltage equal to the rating of the controller you want to test. You can use either a string of batteries or a regulated line-operated power supply. Because only low power tests will be described, a 10 amp fuse should be wired in series with the batteries to protect both operator and controller against accidental shorts. A battery charger alone should not be used as a power supply, because without a battery load its output voltage may exceed the rating of the controller.
- a THROTTLE POTBOX. For controllers with the standard throttle input configuration (a 5 k Ω pot wired as a two-terminal rheostat), a Curtis PMC potbox or any 5 k Ω pot will work fine. For controllers with other input options, use whatever kind of throttle is used on the vehicle.
- a POWER SWITCH to disconnect all power from the test setup.
- a MAIN CONTACTOR with a 250 ohm, 5 watt resistor across its high-power contacts and a KEYSWITCH to turn it on and off.

- FORWARD/REVERSE CONTACTORS and a single-pole, center-off FORWARD/REVERSE SWITCH.
- a BYPASS CONTACTOR if one is used in the vehicle.
- a TEST LOAD consisting of incandescent light bulbs wired in series to get the same voltage as your power supply. (For example, with a 36 volt battery, use three 12 volt bulbs.)
- a FAULT SWITCH (a simple on/off switch) to simulate a fault condition.
- a general purpose VOLT OHMMETER or DIGITAL VOLT-METER.

Pin detail for Fig. 18

- P1 □ KSI input
- P2 □ F/R output
- P3 □ Bypass output
- P4 □ (n/c)
- P5 □ FWD input
- P6 □ REV input

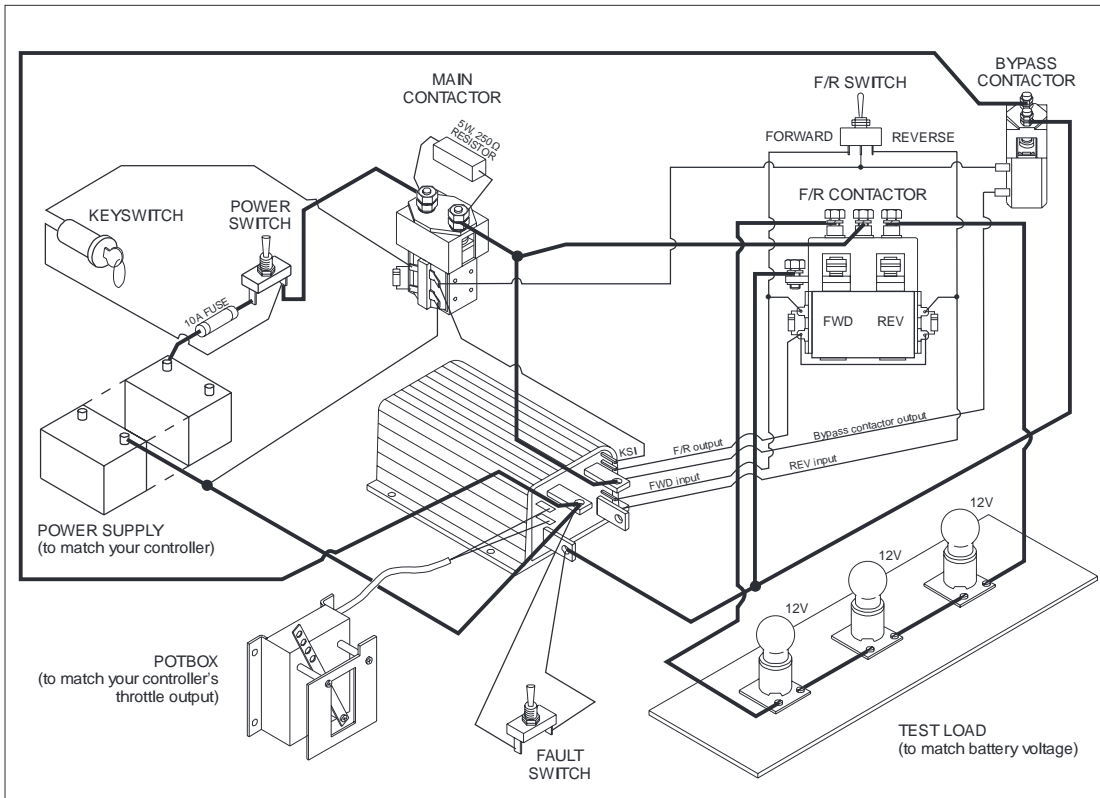

Fig. 18 Setup for bench testing

Bench Test Procedure

- A. Hook up the controller as shown. Connect the voltmeter leads to the controller's B+ and B- terminals. Make sure the fault switch is OFF!
- B. Turn on the power switch (not the keyswitch) and watch the voltmeter. Its reading should build up slowly over several seconds to within a couple of volts of full battery voltage. If this voltage does not come up, the controller is bad.
- C. Now turn on the keyswitch. The main contactor should turn on and the voltage at the controller's B+ and B- terminals should now equal the full battery voltage. Move the throttle through its range. The lamps should remain off.
- D. Select "forward" with the forward/reverse switch. The forward contactor should turn on. Increase the throttle and watch the lamp brightness. The lamps should go smoothly from full off to full on over the throttle range. If a bypass contactor is connected, it should turn off quickly when the throttle is returned to full off.
- E. Repeat step D, selecting "reverse" with the forward/reverse switch.
- F. If the controller has the SRO option, test it as follows:
 1. Turn off the keyswitch (which will serve as the SRO interlock for this test).
 2. Select "forward" with the forward/reverse switch. The forward contactor should remain off.
 3. Turn on the keyswitch. The forward contactor should still remain off, and the lamps should not turn on when the throttle is moved through its range.
 4. Move the forward/reverse switch back to "neutral" (center), and then select "forward" again. This time, the forward contactor should turn on; moving the throttle through its range should change lamp brightness; and the bypass contactor (if one is used) should turn on a couple of seconds after the throttle reaches full on and should turn off quickly when the throttle is returned to full off.
- G. With the controller on and operating in the forward direction, check the controller's fault detect feature as follows:
 1. Move the throttle to full on. The lamps should be at full brightness.

2. Turn on the fault switch, shorting M- to B-. The lamps should remain at full brightness.
 3. Move the throttle to at least halfway toward off. The forward contactor and the lamps should turn off.
 4. Move the forward/reverse switch to neutral and then back to forward. The forward contactor should not turn on, because the fault is still on.
 5. Turn off the fault switch.
 6. Move the forward/reverse switch to neutral and then back to forward. The forward contactor should now turn on and the controller should operate properly.
- H. If the controller has HPD, test this feature as follows:
1. Turn off the keyswitch.
 2. Select neutral.
 3. Move the throttle to about halfway.
 4. Turn the keyswitch switch on and select a direction. Verify that the lamps do not come on until the throttle is moved most of the way toward OFF and then moved back up.
- I. Test the controller's throttle fault protection feature by pulling off one of the throttle's two connections to the controller's throttle input terminals while the lamps are on (throttle in the ON position). The lamps should turn off. With the throttle still in the ON position, reconnect the wire. The lamps should smoothly increase in brightness to their previous level.
- J. Finally, remove the controller from the test setup and check its internal plug diode, as described in Troubleshooting Procedure **4-G**.

6

GLOSSARY: FEATURES and FUNCTIONS

Acceleration rate

A built-in acceleration rate circuit maintains a maximum rate of power increase to the motor. If the throttle is applied full on at start-up, the acceleration rate setting determines how quickly the controller output increases. The standard setting is such that with the throttle full on, the controller requires approximately one second to reach full output. This feature contributes to smooth, gentle starts.

The acceleration rate is adjustable via an externally accessible trimpot; see Section 4 for adjustment instructions. The deceleration rate is fixed, and cannot be adjusted.

Arcless contactor switching

Each time the forward/reverse switch passes through neutral, the controller's output is rapidly turned off (even if the throttle is held on) so that all motor current has stopped by the time the forward/reverse contactor drops out. Controller output always starts at zero and increases smoothly at the set acceleration rate each time a new direction is selected. As a result, forward/reverse switching is arcless.

Bypass contactor switching is also arcless, provided the current being interrupted is below the controller's current limit.

Bypass (1A) [OPTIONAL FEATURE]

If the throttle input is greater than 90% for more than one second, the controller's bypass contactor output is turned on. This closes the bypass contactor that connects M- directly to B-, thus connecting the motor directly to the battery. Bypass allows the motor current to exceed the maximum controller current limit, giving the operator access to more torque (for getting the vehicle out of a hole, for example, or up a ramp). A fuse should be installed in the power wiring circuit to protect the motor when using bypass.

Curtis PMC controllers are so efficient that the difference in efficiency when operating with and without bypass is negligible. The main advantage of bypass is the additional torque it can provide in overload conditions.

The 1204X/1205X/1209/1221 controllers are available with or without the bypass feature in the 12V and 24-36V models. The bypass option is not available in the higher powered models.

Controller fault protection

Faults can be caused internally (e.g., failed electronic components) or externally (e.g., wrench dropped across controller terminals). When a fault is detected, the controller's forward/reverse and bypass contactor outputs are turned off.

Faults are detected by monitoring the controller's M- output. M- should periodically go high; if it remains low for more than 20 ms, a fault is detected. Fault protection is disabled for throttle input greater than 80%; this prevents full speed and normal bypass mode from being detected as faults.

To recover from a fault, the forward/reverse switch must be turned off and back on again. For controllers with SRO, the SRO sequence must be initiated. If the fault has been corrected, the controller will turn back on.

Current limiting

Curtis PMC controllers limit the motor current to a preset maximum. This feature protects the controller from damage that might result if the current were limited only by motor demand.

In addition to protecting the controller, the current limit feature also protects the rest of the system. By eliminating high current surges during vehicle acceleration, stress on the motor and batteries is reduced and their efficiency and service life are improved. Similarly, there is less wear and tear on the vehicle drivetrain, as well as on the ground on which the vehicle rides (an important consideration with golf courses and tennis courts, for example).

The maximum motor current can be factory-set to a lower value than the standard maximum, if requested. In addition, the current limit is field adjustable (see Section 4).

Current multiplication

During acceleration and during reduced speed operation, the Curtis PMC controller allows more current to flow into the motor than flows out of the battery. The controller acts like a dc transformer, taking in low current and high voltage (the full battery voltage) and putting out high current and low voltage. The battery needs to supply only a fraction of the current that would be required by a conventional controller (in which the battery current and motor current are always equal). The current multiplication feature gives vehicles using Curtis PMC controllers dramatically greater driving range per battery charge.

Emergency reverse [OPTIONAL FEATURE]

Emergency reverse (labeled "Emergency Reverse") switches can be mounted on the handles of walkie vehicles. The emergency reverse switch is wired to the controller, reverse contactor, and throttle pot in such a way that if the button is pressed against the

operator by the advancing vehicle, the controller provides enhanced plug braking current to stop the vehicle quickly and reverse its direction.

The 1204X/1205X/1209/1221 controllers are available either with or without the emergency reverse feature.

Environmental protection

Curtis PMC 1204X/1205X/1209/1221 controllers are housed in rugged anodized aluminum extrusions that provide environmental protection. Controllers must be kept clean and dry, however, to ensure long life.

ET-series electronic throttles

The ET-XXX is a wigwag-style throttle control assembly, manufactured by Hardellet for Curtis. It provides a 0–5V signal in both the forward and reverse directions along with high side coil drivers for the forward and reverse contactor coils.

High current coil drivers

The 1204X/1205X/1209/1221 controllers are available, on request, with high current drivers for the forward/reverse and bypass contactor coil inputs. These high current coil drivers, which are rated at 2 amps rather than the standard 1 amp, are necessary to accommodate contactors with rated coil currents above 1 amp. The recommended Albright contactors do not require high current coil drivers.

High pedal disable (HPD) [OPTIONAL FEATURE]

By preventing the vehicle from being turned on with the throttle applied, HPD ensures the vehicle starts smoothly and safely. If the operator attempts to start the vehicle when the throttle is already applied, the controller (and the vehicle) will remain off. For the vehicle to start, the controller must receive an input to KSI before receiving a throttle input. In addition to providing routine smooth starts, HPD also protects against accidental sudden starts if problems in the throttle linkage (e.g., bent parts, broken return spring) give a throttle input signal to the controller even with the throttle released.

The 1204X/1205X/1209/1221 controllers are available either with or without the HPD feature.

KSI

KSI (Key Switch Input) provides power to the controller's logic circuitry via both the keyswitch and the footpedal microswitch. KSI should be used to turn the controller on and off.

MOSFET

A MOSFET (Metal Oxide Semiconductor Field Effect Transistor) is a type of transistor characterized by its fast switching speeds and very low losses.

Overtemperature

See Thermal protection.

Overvoltage cutoff

Overvoltage cutoff inhibits the PWM and opens the contactors, preventing operation when battery voltages are too high for proper functioning. This protects the controller and motor from possible damage due to the overvoltage condition. Overvoltage can result during battery charging or from an improperly wired controller. Controller operation resumes when the voltage is brought within the acceptable range. The cutoff voltage and re-enable voltage are percentages of the battery voltage and are set at the factory.

Plug braking

The vehicle can be braked electrically by selecting the opposite direction with the forward/reverse switch without releasing the throttle. When the motor is reversed, the armature acts as a generator; the controller regulates the current in the motor field winding to give an appropriate level of plug braking torque. The vehicle brakes smoothly to a stop, then accelerates in the other direction. (NOTE: The controller may be unable to provide plug braking if the vehicle is moving too slowly for the motor to generate the necessary plug braking current.)

The plug current limit is factory set to meet customer requirements. In addition, the plug current limit is adjustable via an externally accessible trimpot; see Section 4 for adjustment instructions.

Two types of plug braking control are available: variable and fixed. Variable plug braking allows the amount of plug braking to be adjusted via the throttle. When direction is reversed, the plug braking current increases as a function of the throttle position. Maximum plug braking will occur at maximum applied throttle. Fixed plug braking, on the other hand, applies the specified amount of braking when the direction is reversed regardless of the amount of throttle applied.

If plug braking is not desired, the vehicle can be wired so that moving the forward/reverse switch through neutral causes the vehicle to freewheel as long as the accelerator is applied. If the throttle is released and reapplied, plug braking will then occur. To inhibit plug braking in this way, your controller must have the optional HPD feature. Wiring details are provided in Section 3.

A 1 kHz tone may be heard during plug braking. This noise is normal and indicates that plugging is taking place. The noise will stop when the plug braking stops.

Pot fault

See Throttle pot fault protection.

PTC

A PTC (Positive Temperature Coefficient) resistor is a resistive element that changes value depending on its temperature. At low temperatures, it has a very low resistance value. As current flows through the PTC, it heats up and at a certain temperature it trips to a higher resistance value. PTCs are used on the keyswitch, forward, and reverse controller inputs to improve performance in freezer and moisture-intensive environments. Their addition increases the standby current to approximately 250 mA on 12V models and 100 mA on 24–36V models.

PWM

PWM (Pulse Width Modulation), also called "chopping," is a technique that switches battery voltage to the motor on and off very quickly, thereby controlling the speed of the motor. Curtis PMC 1200 series controllers use high frequency PWM—15 kHz—which permits silent, efficient operation. PWM is described in more detail in Appendix B.

Smooth, stepless operation

Like all Curtis PMC 1200 Series controllers, 1204X/1205X/1209/1221 models allow superior operator control of the vehicle's drive motor speed. The amount of current delivered to the motor is set by varying the "on" time (duty cycle) of the controller's power MOSFET transistors. This technique—pulse width modulation (PWM)—permits silent, stepless operation.

Static return to off (SRO) [OPTIONAL FEATURE]

The SRO feature prevents the vehicle from being started when "in gear." If the operator attempts to start the vehicle while in forward or reverse, the controller (and the vehicle) will remain off. For the vehicle to start, the controller must receive an input to KSI from the designated SRO interlock before receiving a forward or reverse input from the forward/reverse switch. Like HPD, this safety feature ensures smooth starts.

The 1204X/1205X/1209/1221 controllers are available either with or without the SRO feature.

Temperature compensation

Internal temperature compensation ensures that the controller's current limit remains constant over varying controller temperatures. This eliminates perfor-

mance variations resulting from variations in controller operating environment temperatures.

Thermal protection

Because of their efficiency and thermal design, Curtis PMC controllers should barely get warm in normal operation. Overheating can occur, however, if the controller is undersized for its application or otherwise overloaded. If the internal temperature of the controller exceeds 75°C (167°F), the main and plug current limits decrease steadily until they are reduced to zero at 95°C (200°F). At the reduced performance level, the vehicle can be maneuvered out of the way and parked. The controller shifts frequency during overtemperature from its normal 15 kHz to 1 kHz, providing an audible tone alerting the operator to the overtemperature. (NOTE: The plug current limit can be made independent of temperature. This ensures full braking capability even in overtemperature conditions. However, it may result in premature plug diode failure due to excessive thermal stresses.)

Full current limit and performance return automatically after the controller cools down. Although this action is not damaging to the controller, it does suggest a mismatch. If thermal cutback occurs often in normal vehicle operation, the controller is probably undersized for the application and a higher current model should be used.

The controller is similarly protected from undertemperature. Should its internal temperature fall below -25°C (-13°F), the current limit decreases to approximately one-half of the set current. When the controller warms up, full current limit and performance return automatically.

Throttle pot fault protection (runaway protection)

To prevent uncontrolled operation, these controllers shut off the motor in the event of an open circuit fault in the throttle or its wiring. The standard configuration is a two-wire pot ranging from 0 ohms for full off to 5000 ohms for full on; if the controller detects an abnormally high throttle input (more than about 1.5 times the normal input resistance), it shuts off its output to the motor, thus preventing a runaway. The controller returns to normal operation when the fault (e.g., broken potbox wiring, broken connectors) has been repaired.

Undertemperature

See Thermal protection.

Undervoltage protection

The control circuitry requires a minimum battery voltage to function properly. The controller is therefore designed so its output is gradually reduced if the

battery voltage falls below a certain level. Cutback voltages for the various models are listed in the specifications (Appendix C). Reducing the output to the motor allows the battery voltage to recover, and an equilibrium is established in which the battery supplies as much current as it can without falling below the cutback voltage.

APPENDIX A

FUNCTIONAL DESCRIPTION

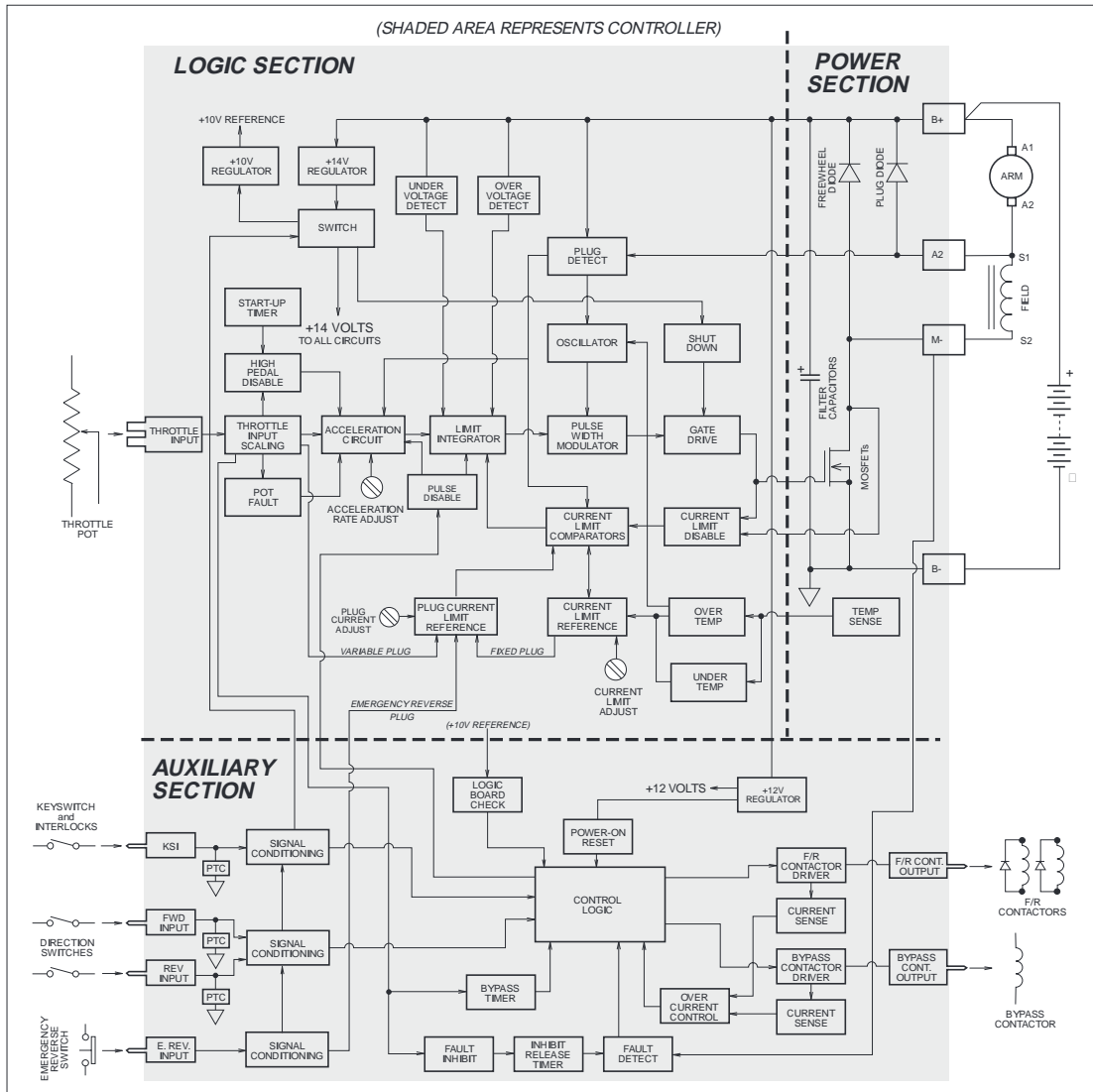

Fig. A-1 Block diagram, Curtis PMC 1204X/1205X/1209/1221 controllers

These controllers consist of three sections: (1) a **POWER SECTION**, (2) a **LOGIC SECTION**, which drives the power section, and (3) an **AUXILIARY SECTION**, which enables and monitors the power and logic sections.

POWER SECTION

An array of paralleled power metal oxide semiconductor field effect transistors (MOSFETs) switches pulses of current from the battery to the motor. During the interval when the MOSFETs are off, the motor current continues to flow in the freewheel diode, which is actually a number of paralleled fast recovery rectifiers. An array of filter capacitors connected directly across the battery provides the instantaneous current required by the power switching circuitry and in this way provides battery ripple current filtering and voltage spike suppression. The plug diode provides a path for armature current to flow during plug braking.

LOGIC SECTION

B- is the ground return for all of the logic and auxiliary circuitry. For systems over 12 volts, the battery supply is regulated down to 14 volts to power the logic circuitry. The output of the 14 volt regulator is switched on and off (switch) by the keyswitch input (KSI) from the auxiliary section to power up the control circuitry when the vehicle is in use and to power it down (shutdown) when the vehicle is not in use. Controller output (PWM pulses) will be inhibited (pulse disable) by the auxiliary section if a fault is detected or until the proper control sequencing is applied to the keyswitch input and forward and reverse inputs.

The speed control input (throttle input) is usually a 5000 ohm, two-wire pot, but other types can be accommodated, so a flexible throttle input scaling circuit conditions the control input to a standard level. This standardized throttle input goes to the acceleration circuit, which limits the rate at which the controller output can increase. The acceleration rate is set by a resistance, and is adjustable via a user accessible trimpot (acceleration ramp adjust).

The output of the throttle input scaling also goes to a pot fault circuit, which turns the controller output off in the event of inputs (e.g., broken wires) that would otherwise cause a runaway. An optional protective feature, high pedal disable (HPD), inhibits controller output if the controller is turned on with the throttle applied. After an interval measured (start-up timer) from the moment the KSI input is turned on, the HPD circuit checks the throttle position. If an applied throttle condition is detected, controller output is held off until the throttle input is returned to zero and then normal operation is allowed.

The control signal then goes to the limit integrator, which reduces the controller output in response to undervoltage, overvoltage, or overcurrent. The time-averaged response of this circuit gives a stable limiting action. The undervoltage detector gives an output when the battery voltage is too low. The reduction in output allows the battery voltage to recover and an equilibrium to be established at a voltage high enough to allow the controller to function properly. The overvoltage detector produces an output when battery voltage is too high (e.g., overcharged batteries) to protect the controller from excessive voltage transients. The current limit function is explained in more detail below.

The heart of the logic circuitry is the pulse width modulator in which the control input derived from the previous stages is compared in magnitude to a 15 kHz sawtooth wave from the oscillator. The resulting pulse output can be smoothly varied between full off and full on. These pulses become the input to the controller's main power MOSFET switch via a gate drive circuit that provides the high pulse currents needed to turn the

power MOSFETs on and off (see Fig. B-1). The shape of the sawtooth wave can be altered so that most of the pulse width change occurs in the earlier or in the latter part of the control input range, giving more sensitive throttle response at high or at low speeds.

Current limiting is done by sensing the voltage drop across the main power MOSFET switch when it is on. This voltage is compared (current limit comparators) with a current limit reference; when it exceeds the reference, an overcurrent signal acts on the limit integrator to reduce the controller output and thus hold the current at the limit. Because the voltage across the power MOSFET switch is high when it is off, the current limit comparison is inhibited during the off interval by the current limit disable circuit. The current limit is set as follows:

1. During manufacture, the current limit is set to the model's nominal rating; it is also user-adjustable by a trimpot (current limit adjust) to currents lower than the nominal rating.
2. During operation at extreme high or low temperatures, current limit is reduced to protect the controller from damage. From a thermal sensor (temp sense) on the heatsink, signals are produced to cut back the current limit at temperatures above 75°C or below -25°C (overtemp, undertemp). The controller's operating frequency shifts to 1 kHz during overtemperature operation, producing an audible tone to alert the operator.
3. During plug braking operation, the current limit is reduced to give an appropriate motor braking torque. The plug braking current is set during manufacture; it is also user-adjustable by a trimpot (plug current adjust).
4. The fixed plug option provides one level of plug braking current independent of throttle position (provided it is at least minimally applied). For the fixed plugging option, the plug current limit reference is derived from the current limit reference.
5. The variable plug option provides variable plug braking current corresponding to the position of the throttle. This allows much smoother braking under control of the operator. For the variable plugging option, the plug current limit reference is derived from the throttle input scaling.
6. The emergency reverse plug option (enhanced plug braking current) is enabled by the emergency reverse input (belly-button switch) from the auxiliary section. This signal increases the plug current limit reference to a fixed value. Plug current limit will be at this enhanced level, independent of accelerator position, even if the variable plug option is installed. Emergency reverse plug current level is set to customer specifications during manufacture and is not user adjustable.

The transition to the plug braking mode is detected (plug detect) by monitoring the voltage across the plug diode. When this diode becomes forward biased, it indicates that the motor field has been reversed and the controller has gone into plug mode. The current limit is reduced as described, and the frequency of the oscillator is reduced from 15 kHz to 1 kHz, to allow finer control of the controller output while plugging. During plug braking operation, the acceleration circuit is reset to a low level so that when drive operation resumes, the controller will go through a normal acceleration ramp. When the motor has come to a stop, the plug diode will again become reverse biased and the controller will revert to normal drive operation.

AUXILIARY SECTION

The auxiliary section accepts all user control from the keyswitch, forward, reverse, and emergency reverse inputs, provides contactor drivers for the direction and optional bypass contactors, and monitors and controls the logic and power sections. Input signal conditioning filters and clamps all inputs to provide logic level signals for the control logic. Three PTC resistors protect the keyswitch, forward, and reverse inputs against erroneous activation from external leakage paths, which can be created by moisture or conductive material that settles between the controller's connections during vehicle use or cleaning. A 12V regulator powered by B+ provides power for all auxiliary section circuits. The auxiliary section power supply is independent of the logic section power supply; logic section failures therefore do not affect the ability of the auxiliary section to detect faults. Power-on reset initializes the control logic when B+ is connected to the controller.

Controllers with SRO (static return to off) must have the proper sequencing of KSI and forward/reverse input, as determined by the control logic, to enable the controller and allow it to operate. KSI must turn on before forward or reverse for the control logic to release pulse disable (thereby turning on the controller). If KSI is turned on simultaneously with or later than forward or reverse, pulse disable will remain on (controller disabled).

Controllers without the SRO option may require a keyswitch input (dependent on vehicle wiring) if the controller has HPD.

A valid turn-on sequence enables the logic section so it will respond to throttle inputs, and turns on the forward/reverse contactor driver to actuate the selected direction contactor. If a fault is detected (fault detect) or the logic board's power supply is out of range (logic board check), the controller and contactor driver will not be allowed to operate even if a valid turn-on sequence occurs.

The bypass contactor driver will turn on the bypass contactor if the requested throttle input level is at least 90% for at least one second (bypass timer). When it reduces below 90%, the bypass contactor is turned off instantly.

Both contactor drivers are short circuit protected. Current sense detects contactor driver current, which then signals over-current control in the event of a shorted contactor. Over-current control responds very rapidly ($\approx 10\mu\text{s}$) to turn off the contactor driver(s) and then waits approximately 10 ms before trying to turn them back on again. If the coil short is still present, over-current control will keep trying to turn back off and on until

the short is removed or the controller turned off. This 10- μ s-on, 10-ms-off timing produces very low power dissipation in the drivers while protecting them from the shorted load.

Fault detect monitors M- to confirm that it periodically goes high. If M- remains low for more than 20 ms, a fault is assumed (internal or external to the controller); the forward/reverse contactor driver is turned off and the logic board pulses are disabled. The controller will remain off until the proper input switch sequencing is re-applied. If the fault is still present, the controller will remain off; otherwise, it will turn back on. Fault detect is inhibited (fault inhibit) for throttle inputs greater than 80% to avoid sensing a false fault when the bypass contactor turns on at 90% throttle input (bypass looks like full speed at M-). The inhibit release timer keeps fault detect inhibited for about 50 ms after the throttle request decreases below 80% duty cycle to allow time for the bypass contactor to drop out. This delay avoids detecting a slowly releasing bypass contactor as a fault.

The emergency reverse input causes the controller to go into plug braking mode with increased current limit. Increasing the current limit is necessary because the standard plug braking current limit is usually not high enough to slow the vehicle fast enough for emergency reversing. The emergency reverse switch is externally wired to a relay that simultaneously selects \square reverse \square and \square full speed \square . The vehicle is suddenly reversed (if in forward) and the controller goes into enhanced plug braking mode to slow the vehicle to a stop before it accelerates away from the operator in reverse.

APPENDIX C

ELECTRICAL SPECIFICATIONS

TABLE C-1 Electrical Specifications, 1204X/1205X

NOMINAL INPUT VOLTAGE	12V, 24–36V, and 36–48V
PWM OPERATING FREQUENCY	15 kHz
CONTROL INPUT LEVEL	
KSI/forward/reverse	from 8 V to 1.5 × maximum battery voltage
Emergency reverse	from undervoltage cutback level to 1.5 × max. battery voltage
STANDBY CURRENT	less than 250 mA
STANDARD THROTTLE INPUT	0–5kΩ ±10% (others available)

MODEL NUMBER	NOMINAL BATTERY VOLTAGE (volts)	CURRENT LIMIT (amps)	2 MIN RATING (amps)	5 MIN RATING (amps)	1 HOUR RATING (amps)	VOLTAGE DROP @ 100 AMPS (volts)	UNDER-VOLTAGE CUTBACK (volts)	MAX TOTAL F/R + 1A CURRENT (amps)
1204X -12XX	12	275	275	200	125	0.35	9	2
-14XX	12	400*	300	210	135	0.25	9	2
-42XX	24–36	275	275	200	125	0.35	16	2
-44XX	24–36	400*	300	210	135	0.25	16	2
-52XX	36–48	275	275	200	125	0.35	21	1
1205X -14XX	12	400	400	275	175	0.25	9	2
-16XX	12	500*	425	285	185	0.20	9	2
-44XX	24–36	400	400	275	175	0.25	16	2
-46XX	24–36	500*	425	285	185	0.20	16	2
-53XX	36–48	350	350	250	150	0.35	21	1

*30-second rating

Table C-2 Electrical Specifications, 1209/1221

NOMINAL INPUT VOLTAGE	24–36V, 36–48V, 48–72V, 48–80V, and 72–120V
PWM OPERATING FREQUENCY	15 kHz
CONTROL INPUT LEVEL	
KSI/forward/reverse	from 8 V to 1.5 x maximum battery voltage
Emergency reverse	from undervoltage cutback level to 1.5 x max. battery voltage
STANDBY CURRENT	less than 100 mA
STANDARD THROTTLE INPUT	0–5k Ω \pm 10% (others available)

MODEL NUMBER	NOMINAL BATTERY VOLTAGE (volts)	CURRENT LIMIT (amps)	2 MIN RATING (amps)	5 MIN RATING (amps)	1 HOUR RATING (amps)	VOLTAGE DROP @ 100 AMPS (volts)	UNDER-VOLTAGE CUTBACK (volts)	MAX TOTAL F/R + 1A CURRENT (amps)
1209 -46XX	24–36	500	500	350	225	0.15	16	2
-55XX	36–48	450	450	300	200	0.30	21	1
-64XX	48–72	400	400	275	175	0.30	32	1
-6A5XX	48–80	450	450	300	200	0.25	32	1
-72XX	72–120	275	275	175	100	0.70	48	1
1221 -48XX	24–36	600	600	425	250	0.10	16	2
-57XX	36–48	550	550	375	225	0.25	21	1
-66XX	48–72	500	500	350	200	0.25	32	1
-6A7XX	48–80	550	550	375	225	0.20	32	1
-74XX	72–120	400	400	250	150	0.50	48	1