

Project Name					
DIGITAL STORAGE OSCILLOSCOPE					
Title					
ADC (CHANNEL 1)					
A			Date		A
			Date		
			Date		
Date:			Sheet of		

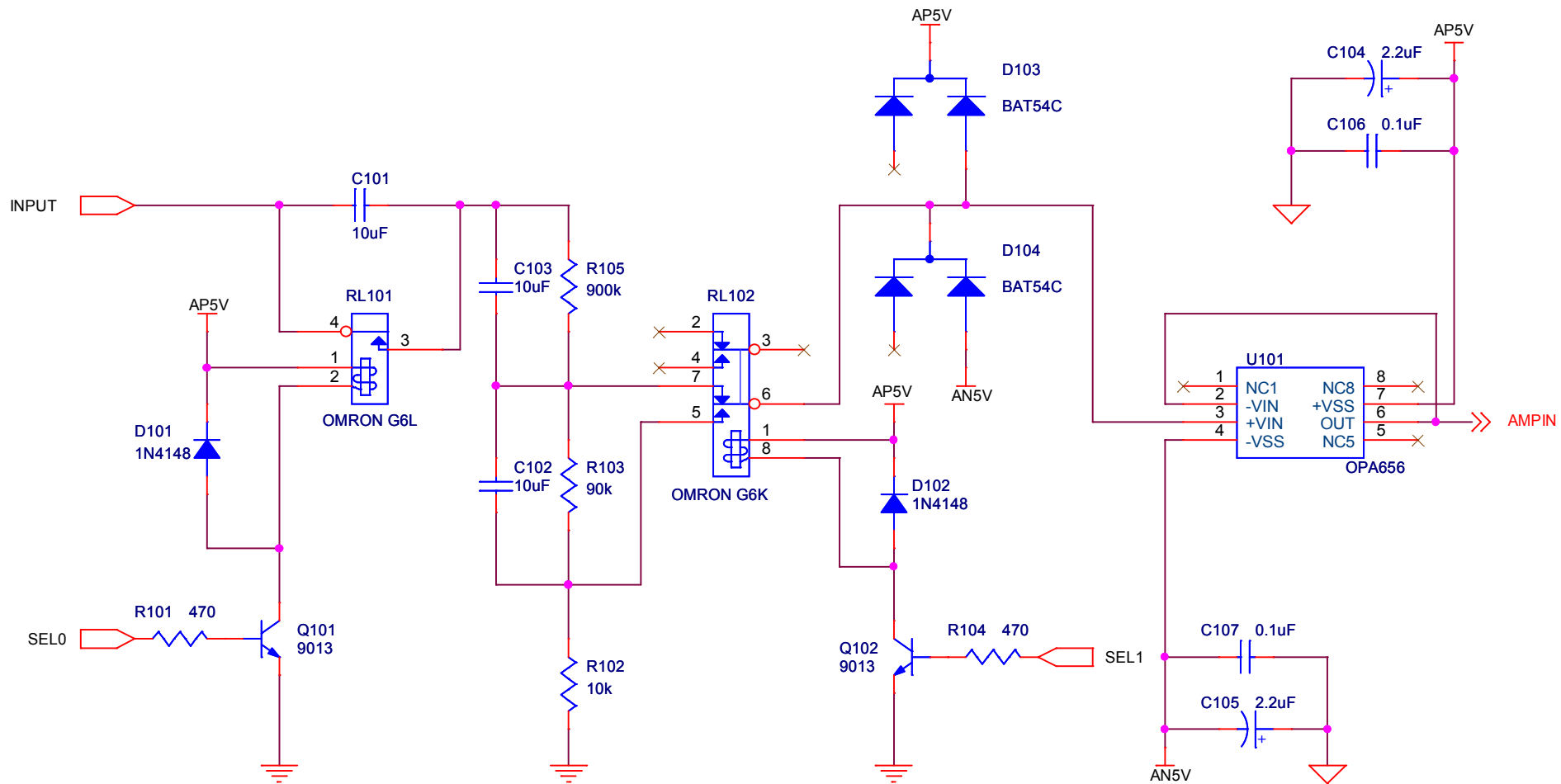

Project Name		DIGITAL STORAGE OSCILLOSCOPE	
Title		ANALOG FRONT END (CHANNEL 1) ATTENUATOR AND COUPLE	
A		Date	
		Date	
		Date	
Date:		Sheet 1 of 1	

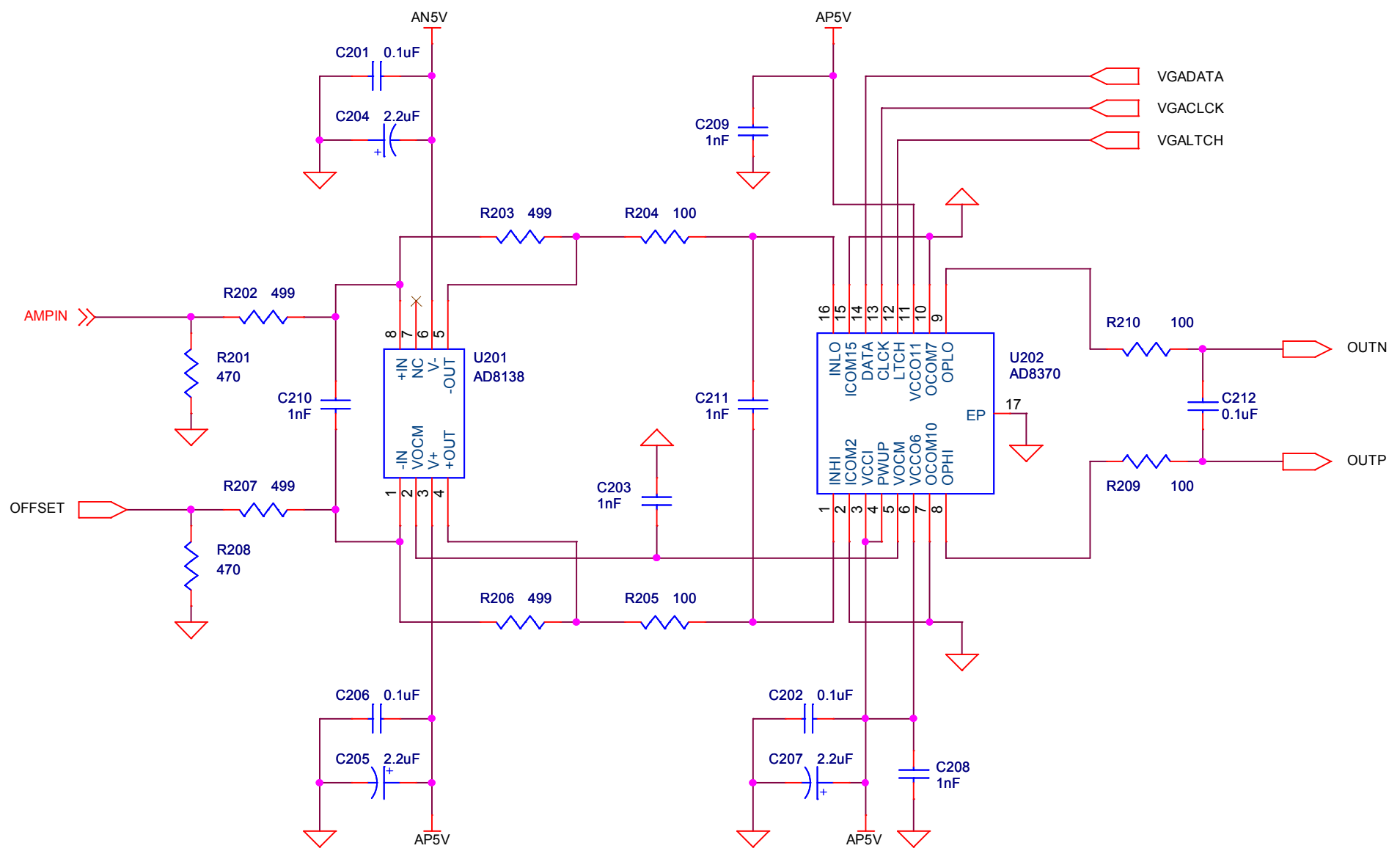

Project Name				DIGITAL STORAGE OSCILLOSCOPE	
Title				ANALOG FRONT END (CHANNEL 1) VARIABLE GAIN AMPLIFIER	
A	Q.C.	Date			A
		Date			
		Date			
Date:				Sheet 1 of	