

Package Outline Drawing of SOIC-8 150 mils

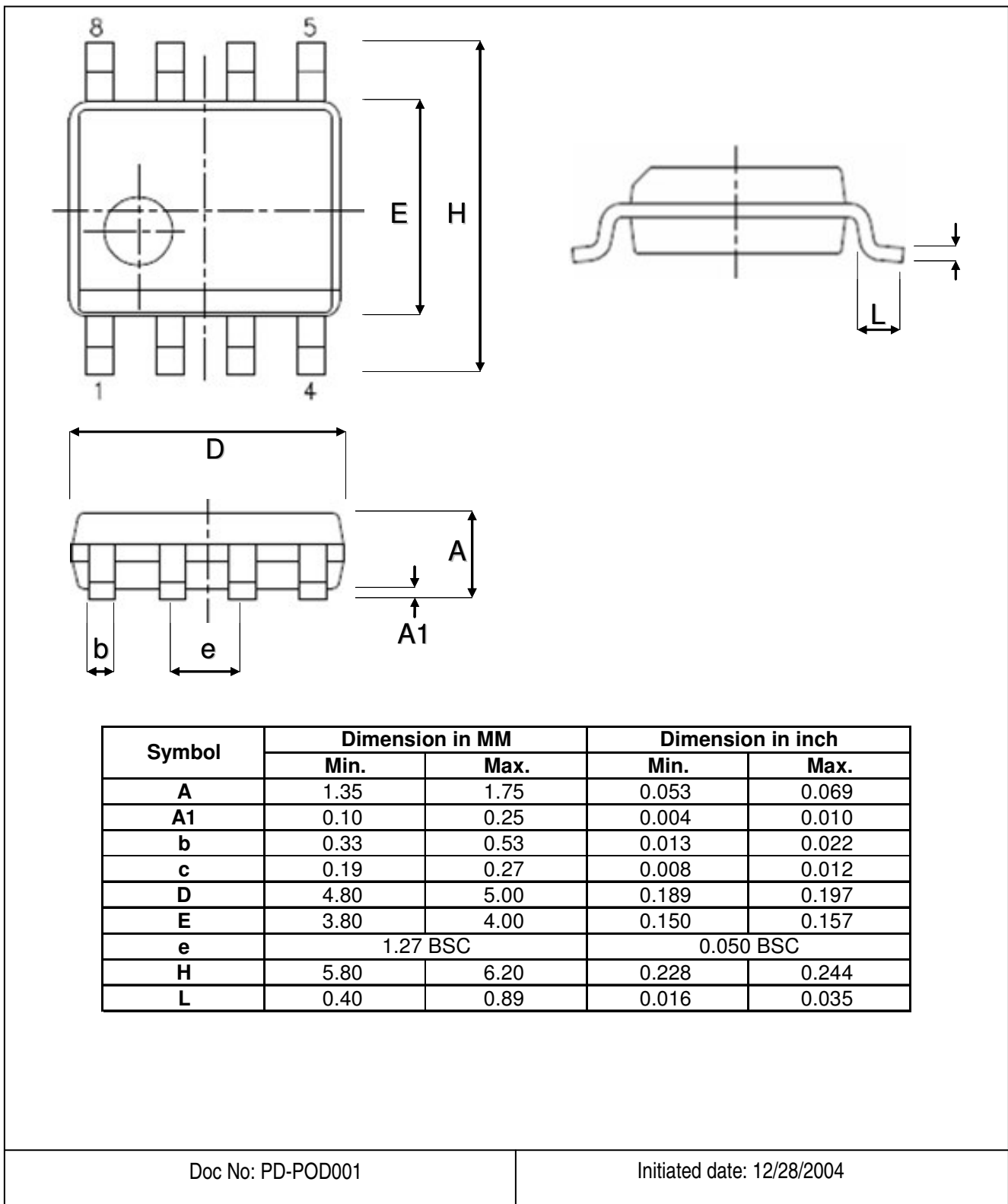

Package Outline Drawing of SOIC-8 150 mils

1. The packing of Tape and reel/Tube:

- Packing quantity:
Packing quantity for T&R production

Package Type	Tape Width (mm)	Package Pitch (mm)	Devices For 13" Reel	Empty Pockets	
				Leader (mm)	Trailer (mm)
SOIC 8L 150mil	12	8	2500 EA	500	500

Packing quantity for tube production

Count NO.	PART NO.	Pin 1/start Plug color	Ending Plug color	Qty / Tube	Tube / Box	Inner box/Qty
SOIC 8L 150mil	14-0020-000A	White	Blue	100	200	20000

- Trailer length 500mm (63 empty pockets) minimum of empty sealed pockets and leader length minimum of 500 mm (63 empty pockets) consisting of empty sealed pockets.
- The between of products of a reel not have any empty pocket.

2. Pull test range : 20g~90g/The range of peel force:20g~90g

3. Orientation of pin 1 of the packages should be towards the circular sprocket hole as follows.

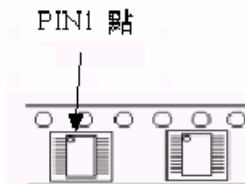

PS: All devices must have same orientation..

4. The same Mother Lot can be merged, use T&R. The packing of the remainder use tube

5. The label of inner carton.

CUSTOMER : P.L.L.
DEVICE NO. : ED8913FTS
LOT NO. : PA98118.1
TEST : FT[] OS[] B/I[]
Q. C. : QTY: TAIWAN

Package Outline Drawing of SOIC-8 150 mils

• LABEL FORMAT DESCRIPTION:

Label format field	Contrast process traveler field
CUSTOMER	CUSTOMER NAME
DEVICE NO.	DEVICE NAME
LOT NO.	CUST LOT NO
TEST	CHOOSE TEST ITEM AS : FT [], OS [], B/I []
Q.C.	N/A
QTY	INNER BOX QTY

6. The packing of inner carton

• The packing of the inner box for tape and reel:

- Use the protective bands to protect it for Carrier tape. Use black adhesive tape on the protective bands
- Complete reel, have a minimum 2 units of desiccant bag, ESD label and BOX label.

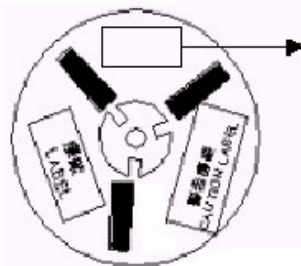

2 單位乾燥劑

A minimum 2 units of desiccant bag

Please use black adhesive tape on the desiccant bag.

- Complete reel must put in antistatic bag, and barrier bag must use ESD label, the pizza box must fill in bubble wrap.

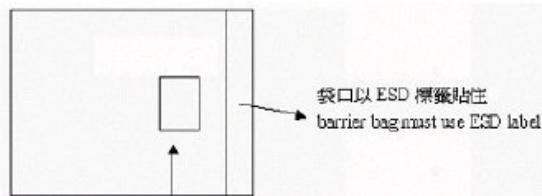

袋口以 ESD 標籤貼住
barrier bag must use ESD label

ESD Logo



Package Outline Drawing of SOIC-8 150 mils

- The packing of the inner box for tube:
 - Input tube use 98ea per tube but output tube must change 100ea per tube on the machine of lead scan. The P/N is 14-0020-000A of 100ea per tube for SOP 150MIL 8L.
 - Don't use filler foam fill in a tube, if the tube is not full.
 - Complete tube must put in antistatic bag (P/N:92-0130-029B), and barrier bag must use ESD label.

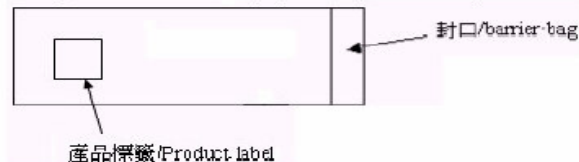

- The inner box of the tube must use OSE box (P/N:16-000-34007).
- The inner box must fill in bubble wrap.

7. The paste of inner carton label.



8. The paste of the outer carton:

- A outer carton must have six inner carton.
- The label of outer carton.



- The paste of the outer carton:

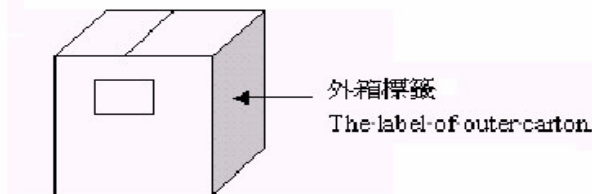

- End of File -

PhaseLink Corporation, reserves the right to make changes in its products or specifications, or both at any time without notice. The information furnished by PhaseLink is believed to be accurate and reliable. However, PhaseLink makes no guarantee or warranty concerning the accuracy of said information and shall not be responsible for any loss or damage of whatever nature resulting from the use of, or reliance upon this product.