

SPECIFICATIONS

STK392-570

外形図 18ピン (別紙外形図面参照)
Case Outline 18pins (See attached case outline dimension.)

機能 電力増幅
Function Power Amplification

用途 プロジェクションTV等
Application Projection TV etc. use

特長 コンバージェンス補正出力 3チャンネル + 出力ミュート回路
Features Convergence Correction Circuit 3 channels and Output Muting Circuit

最大定格/Ta=25°C
Absolute Maximum Ratings at Ta=25°C

項目 Parameter	記号 Symbol	条件 Conditions	最大定格値 Ratings	単位 Unit
電源電圧 Supply Voltage	Vcc max		±50	V
コレクタ電流 Collector Current	Ic max	TR9,10,17,18,25,26	±8	A
熱抵抗 Thermal Resistance	θ_{j-c}	TR9,10,17,18,25,26 (一石当り)(Per TR)	2.0	°C/W
接合部温度 Junction Temperature	Tj max		150	°C
動作時IC基板温度 Operating IC Substrate Temperature	Tc max		125	°C
保存周囲温度 Storage Temperature	Tstg		-30 ~ +125	°C

動作特性/Tc=25°C, Vcc=±40V, 別紙測定回路図参照
Operating Characteristics at Tc=25°C, Vcc=±40V, See attached Test Circuit

項目 Parameter	記号 Symbol	条件 Conditions	規格値 Ratings			単位 Unit
			min.	typ.	max.	
無信号時電流 Quiescent Current	Icco		35	80	110	mA
中点電圧 Neutral Voltage	VN		-50	-	+50	mV
スルーレート Slew Rate	SR		-	50	-	V/μs
ミュート端子入力電圧 Mute Pin Input Voltage	V _{IH}	2 pin	2.0	-	-	V
	V _{IL}		-	-	0.8	

備考
Note

- 検査時の電源には、指定のないかぎり定電圧電源を使用する。
Use a constant-voltage power supply during test unless otherwise specified.

M. Yamugishi
K. Arai, H. Asado

SP392570A

端子機能図
Pin Description

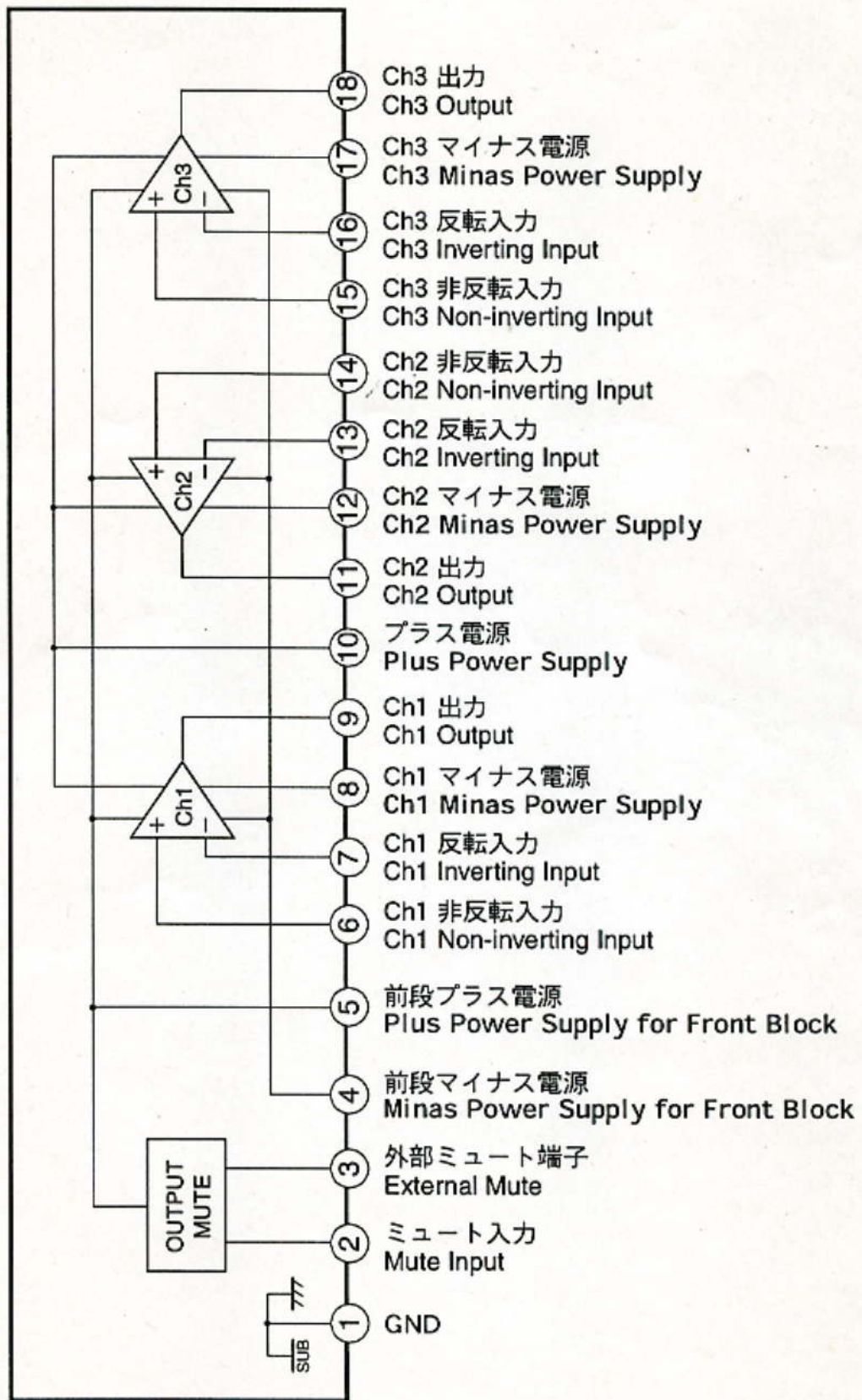

AX392500XAA0

内部等価回路
Equivalent Circuit

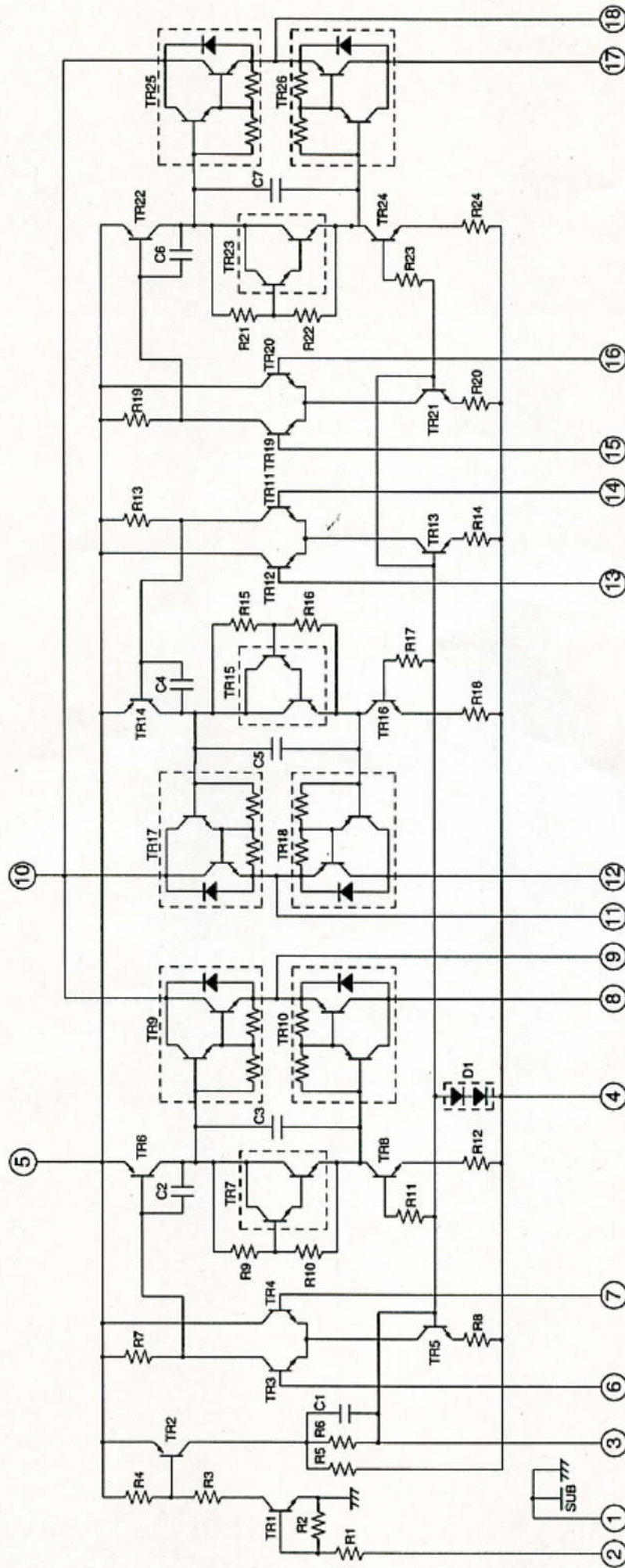

測定回路
Test Circuit

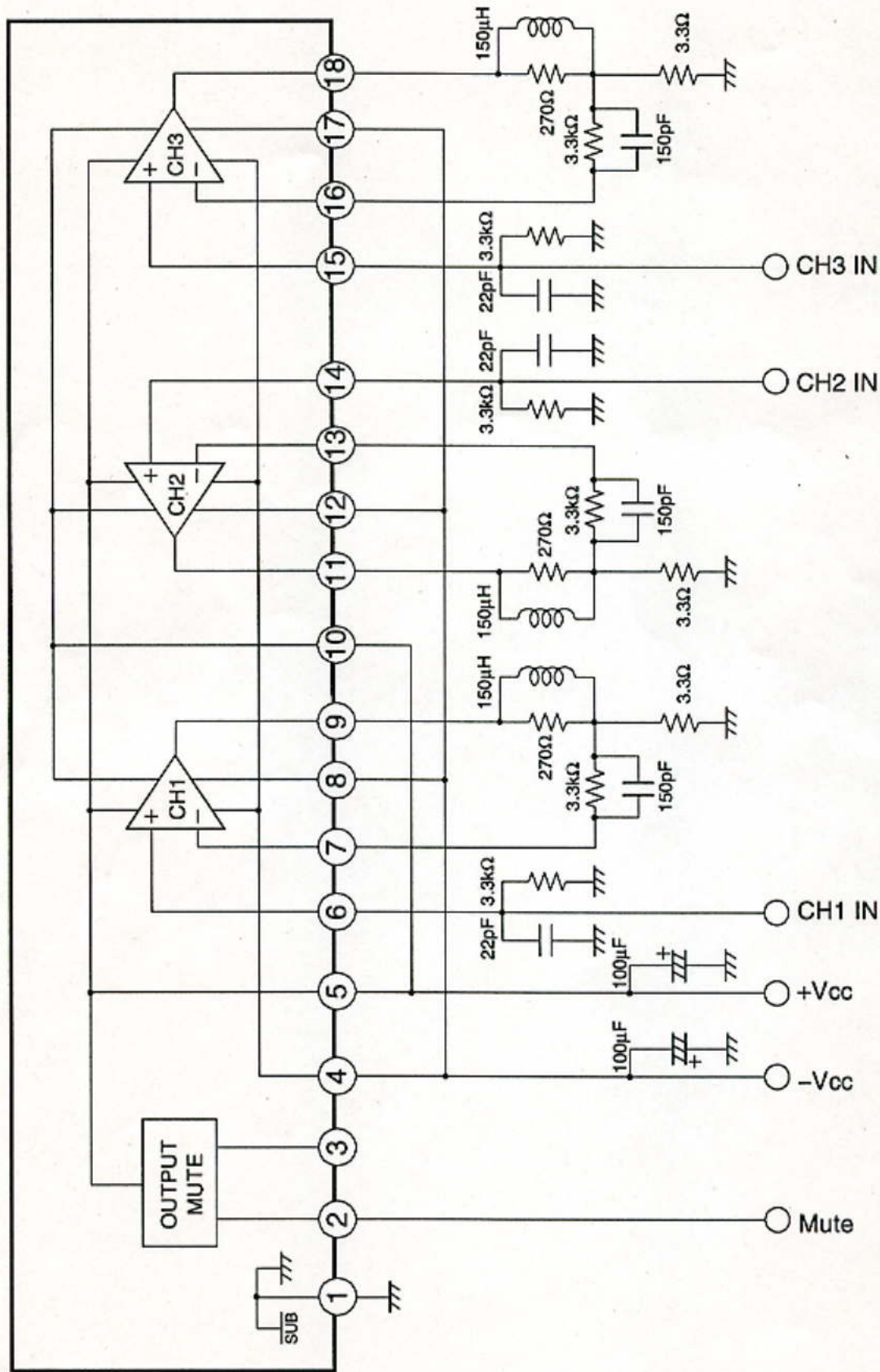

Mute Input
Low : Output Disabled
High : Output Enabled

AX392500XMA0

応用回路例

Sample Application Circuit

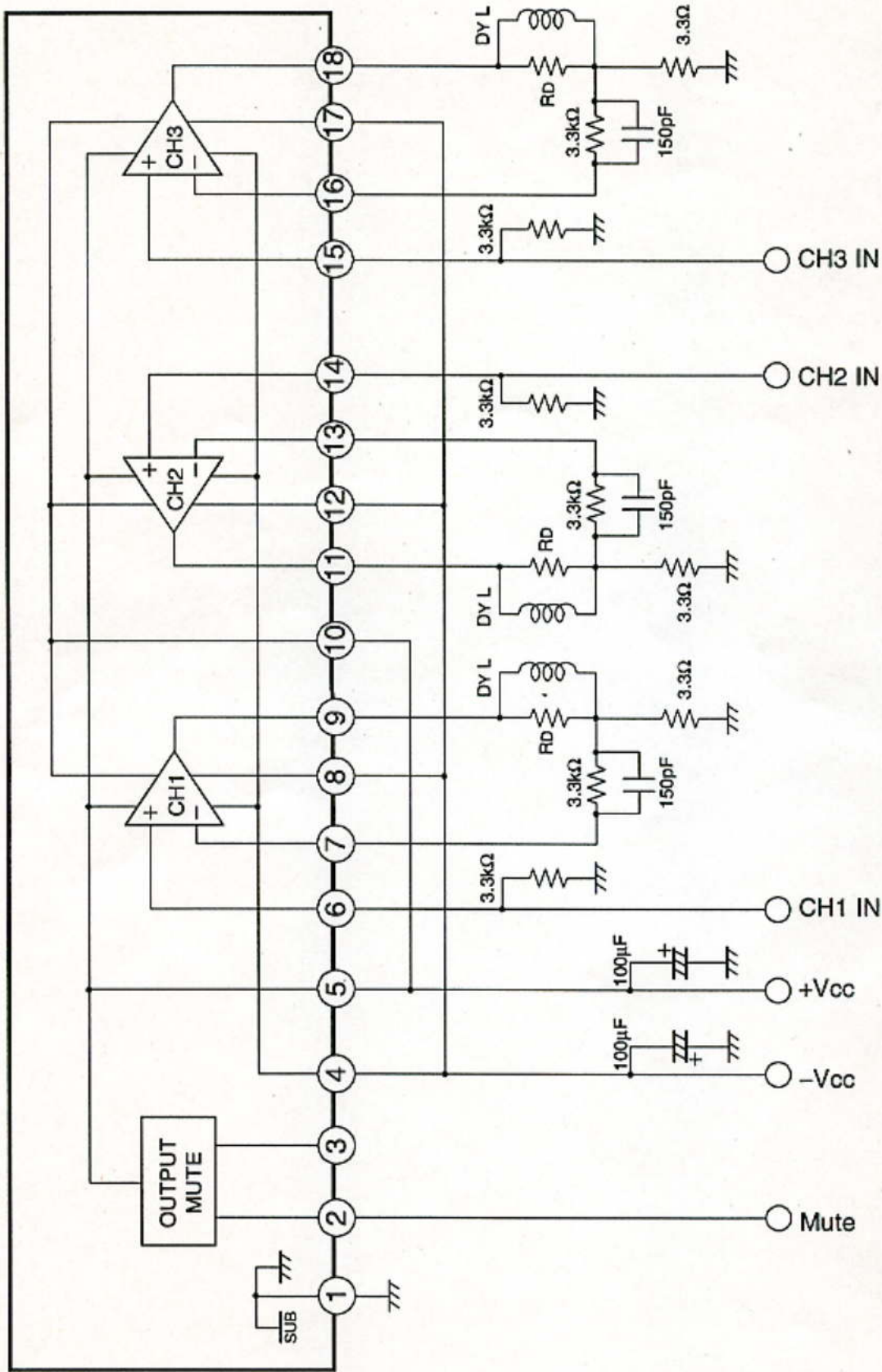

Mute Input
 Low : Output Disabled
 High : Output Enabled

AX392500XAB0

PACKAGE DIMENSION

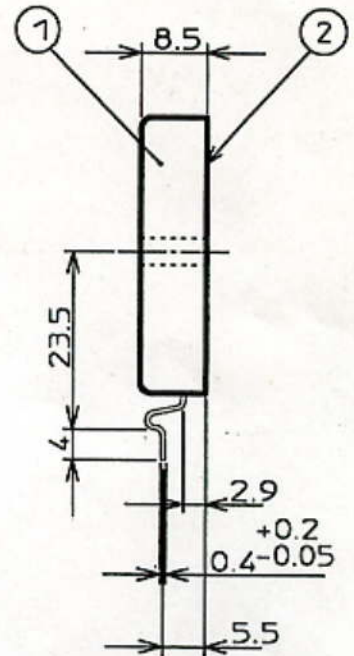
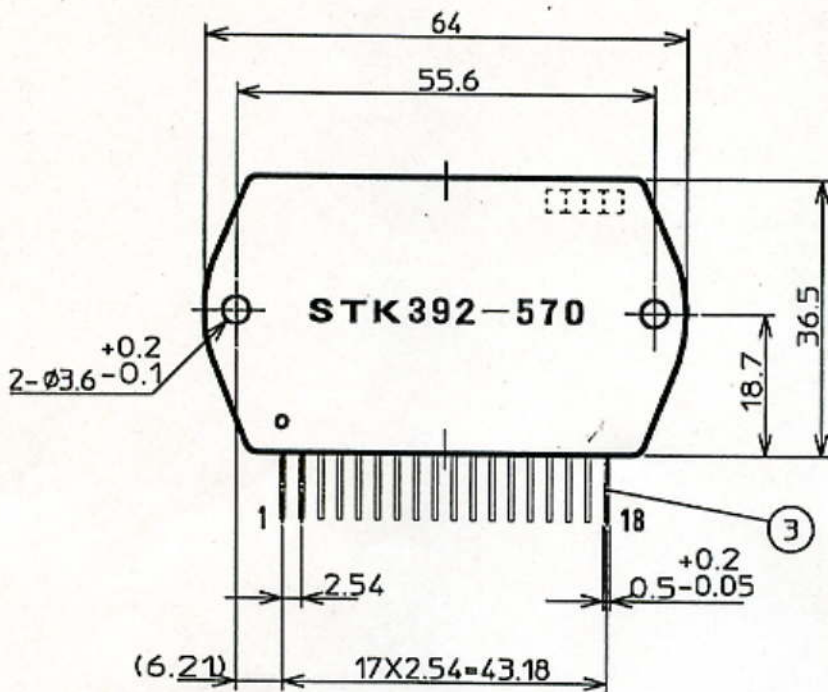

5 - 5461

(*) : A dimple mark for No1 pin identification

SCALE : 1 / 1	UNIT : mm
TOLERANCES UNLESS OTHERWISE SPECIFIED : ± 0.5	

DO NOT SCALE THIS DRAWING

	MATERIAL	TREATMENT		
①	PET(FR)			
②	IMST SUBSTRATE			
③	SPCC-SB	COPPOR/SOLDER PLATING		

DR.	<i>O. Nakamoto</i>	DATE	<i>Dec 14 / 1999</i>	NAME	STK392-570	PART No.	
CK.	<i>N. Sakamoto</i>	APPR.	<i>M. Yamaguchi</i>	OUTLINE	EIAJ _____ JEDEC _____ SANYO _____		