

**Features**

- Wide 5V to 65V Operation Voltage
- Output Adjustable from 1.25V to 25V
- Maximum Duty Cycle 100%
- Minimum Drop Out 1V
- Fixed 200KHz Switching Frequency
- Maximum 0.5A Output Current
- Recommend output power less than 8W
- Internal Optimize HV Power Transistor
- High efficiency up to 85%
- Excellent line and load regulation
- TTL shutdown capability
- Built in thermal shutdown function
- Built in output short Protection Function
- Built in current limit function
- SOP8-EP (Exposed PAD) package

**Applications**

- Ebike Controller Power Supply
- Telecom / Networking Equipment

**General Description**

The XL7005 is a 200KHz fixed frequency PWM buck (step-down) DC/DC converter, capable of driving a 0.5A load with high efficiency, low ripple and excellent line and load regulation. Requiring a minimum number of external components, the regulator is simple to use and include internal frequency compensation and a fixed-frequency oscillator.

The PWM control circuit is able to adjust the duty ratio linearly from 0 to 100%. An enable function, an over current protection function is built inside. When output short protection function happens, the operation frequency will be reduced from 200KHz to 45KHz. An internal compensation block is built in to minimize external component count.

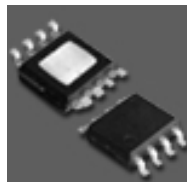

Figure1. Package Type of XL7005

## Pin Configurations

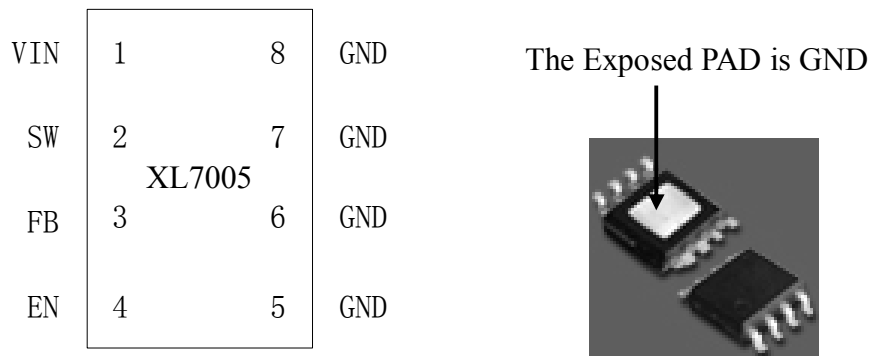

Figure2. Pin Configuration of XL7005 (Top View)

Table 1 Pin Description

Pin Number	Pin Name	Description
1	VIN	Supply Voltage Input Pin. XL7005 operates from a 5V to 65V DC voltage. Bypass Vin to GND with a suitably large capacitor to eliminate noise on the input.
2	SW	Power Switch Output Pin (SW). Output is the switch node that supplies power to the output.
5~8	GND	Ground Pin. Care must be taken in layout. This pin should be placed outside of the Schottky Diode to output capacitor ground path to prevent switching current spikes from inducing voltage noise into XL7005. The exposed PAD is GND.
3	FB	Feedback Pin (FB). Through an external resistor divider network, Feedback senses the output voltage and regulates it. The feedback threshold voltage is 1.25V.
4	EN	Enable Pin. Drive EN pin low to turn on the device, drive it high to turn it off. Floating is default low.

**0.5A 200KHz 65V Buck DC to DC Converter** **XL7005**

### Function Block

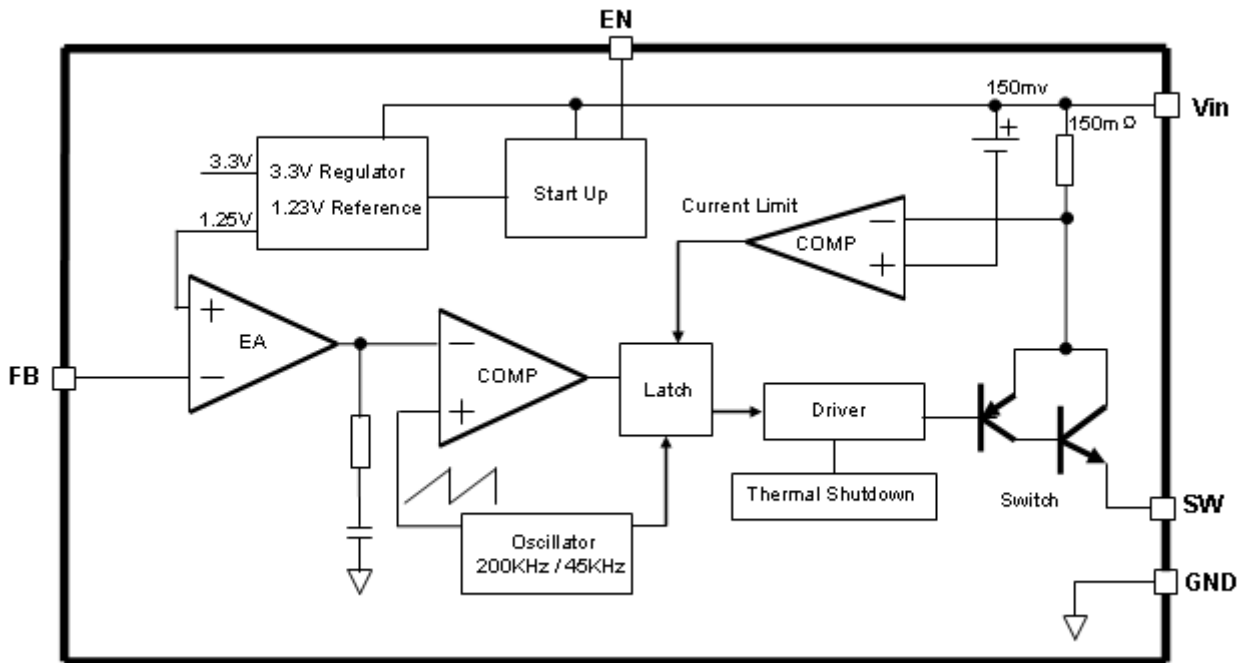

Figure3. Function Block Diagram of XL7005

### Typical Application Circuit

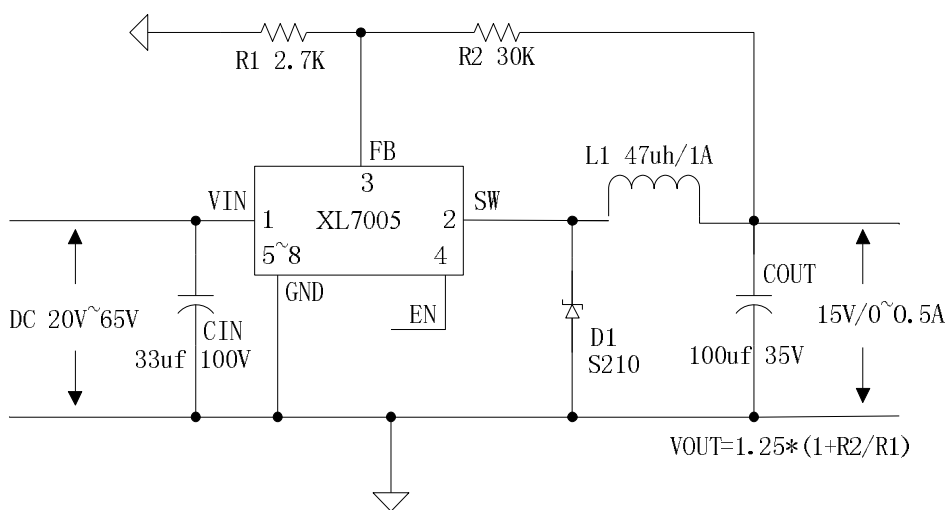

Figure4. XL7005 Typical Application Circuit

### 0.5A 200KHz 65V Buck DC to DC Converter

XL7005

#### Ordering Information

Order Information	Marking ID	Package Type	Packing Type Supplied As
XL7005E1	XL7005E1	SOP8-EP	2500 Units on Tape & Reel

XLSEMI Pb-free products, as designated with “E1” suffix in the par number, are RoHS compliant.

#### Absolute Maximum Ratings (Note1)

Parameter	Symbol	Value	Unit
Input Voltage	$V_{in}$	-0.3 to 70	V
Feedback Pin Voltage	$V_{FB}$	-0.3 to $V_{in}$	V
EN Pin Voltage	$V_{EN}$	-0.3 to $V_{in}$	V
Output Switch Pin Voltage	$V_{SW}$	-0.3 to $V_{in}$	V
Power Dissipation	$P_D$	800	mW
Thermal Resistance (SOP8-EP) (Junction to Ambient, No Heatsink, Free Air)	$R_{JA}$	60	°C/W
Operating Junction Temperature	$T_J$	-40 to 125	°C
Storage Temperature	$T_{STG}$	-65 to 150	°C
Lead Temperature (Soldering, 10 sec)	$T_{LEAD}$	260	°C
ESD (HBM)		>3000	V

**Note1:** Stresses greater than those listed under Maximum Ratings may cause permanent damage to the device. This is a stress rating only and functional operation of the device at these or any other conditions above those indicated in the operation is not implied. Exposure to absolute maximum rating conditions for extended periods may affect reliability.

### 0.5A 200KHz 65V Buck DC to DC Converter

### XL7005

#### XL7005 Electrical Characteristics

$T_a = 25^\circ\text{C}$ ; unless otherwise specified.

Symbol	Parameter	Test Condition	Min.	Typ.	Max.	Unit
<i>System parameters test circuit figure4</i>						
VFB	FB Voltage	$V_{in} = 20\text{V to } 65\text{V}$ $I_{load} = 0.05\text{A to } 0.5\text{A}$	1.213	1.25	1.287	V
Efficiency	$\eta$	$V_{in} = 36\text{V}, V_{out} = 15\text{V}$ $I_{out} = 0.5\text{A}$	-	83	-	%
Efficiency	$\eta$	$V_{in} = 48\text{V}, V_{out} = 15\text{V}$ $I_{out} = 0.5\text{A}$	-	81	-	%
Efficiency	$\eta$	$V_{in} = 60\text{V}, V_{out} = 15\text{V}$ $I_{out} = 0.5\text{A}$	-	76	-	%

#### Electrical Characteristics (DC Parameters)

$V_{in} = 48\text{V}$ ,  $GND = 0\text{V}$ ,  $V_{in}$  &  $GND$  parallel connect a  $33\mu\text{f}/100\text{V}$  capacitor;  $I_{out} = 0.2\text{A}$ ,  $T_a = 25^\circ\text{C}$ ; the others floating unless otherwise specified.

Parameters	Symbol	Test Condition	Min.	Typ.	Max.	Unit
Input operation voltage	$V_{in}$		5		65	V
Shutdown Supply Current	$I_{STBY}$	$V_{EN} = 2\text{V}$		85	200	$\mu\text{A}$
Quiescent Supply Current	$I_q$	$V_{ON/OFF} = 0\text{V}$ , $V_{FB} = V_{in}$		2.5	5	mA
Oscillator Frequency	$F_{osc}$		150	200	275	KHz
Switch Current Limit	$I_L$	$V_{FB} = 0$		1		A
EN Pin Threshold	$V_{EN}$	High (Regulator OFF) Low (Regulator ON)		1.6 0.8		V
EN Pin Input Leakage Current	$I_H$	$V_{EN} = 2.5\text{V (OFF)}$		6	20	$\mu\text{A}$
	$I_L$	$V_{EN} = 0.5\text{V (ON)}$		1	10	$\mu\text{A}$
Output Saturation Voltage	$V_{CE}$	$V_{FB} = 0\text{V}$ $I_{out} = 0.5\text{A}$		0.88	1	V
Max. Duty Cycle	$D_{MAX}$	$V_{FB} = 0\text{V}$		100		%

## Typical System Application

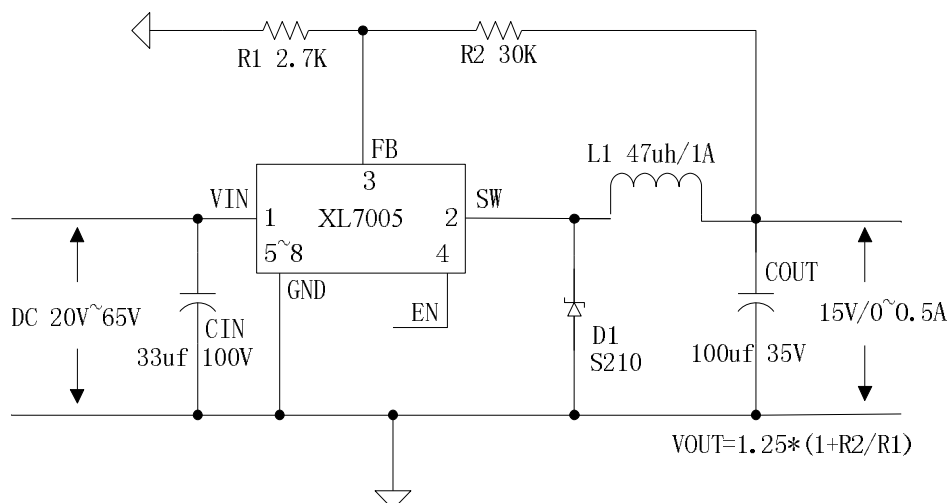
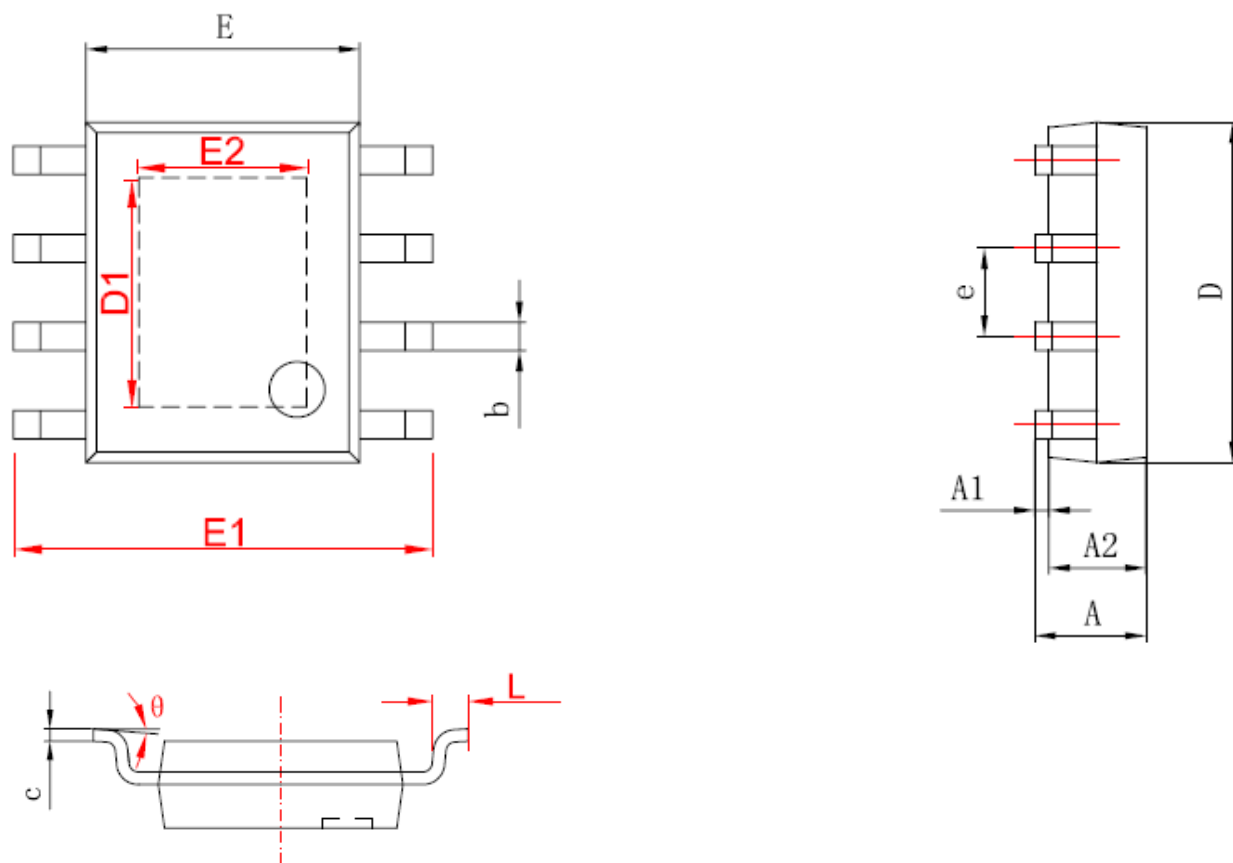

Figure5. XL7005 System Application ( $V_{IN}=20V \sim 65V$ ,  $V_{OUT}=15V$ )

## Package Information

### Package Information (SOP8-EP)



字符	Dimensions In Millimeters		Dimensions In Inches	
	Min	Max	Min	Max
A	1.350	1.750	0.053	0.069
A1	0.050	0.150	0.004	0.010
A2	1.350	1.550	0.053	0.061
b	0.330	0.510	0.013	0.020
c	0.170	0.250	0.006	0.010
D	4.700	5.100	0.185	0.200
D1	3.202	3.402	0.126	0.134
E	3.800	4.000	0.150	0.157
E1	5.800	6.200	0.228	0.244
E2	2.313	2.513	0.091	0.099
e	1.270 (BSC)		0.050 (BSC)	
L	0.400	1.270	0.016	0.050
θ	0°	8°	0°	8°