

THIS DRAWING IS THE PROPERTY OF ANALOG DEVICES INC. IT IS NOT TO BE REPRODUCED OR COPIED, IN WHOLE OR IN PART, OR USED IN FURNISHING INFORMATION TO OTHERS, OR FOR ANY OTHER PURPOSE DETRIMENTAL TO THE INTERESTS OF ANALOG DEVICES. THE EQUIPMENT SHOWN HEREON MAY BE PROTECTED BY PATENTS OWNED OR CONTROLLED BY ANALOG DEVICES.

### RELAY CONTROL CHART

CONTROL	CODE	DEVICE	FUNCTION	CONNECTOR

JUMPER TABLE		
JP#	ON	OFF
1		
2		
3		
4		
5		

\* SEE ASSEMBLY INSTRUCTIONS

REVISIONS			
REV	DESCRIPTION	DATE	APPROVED
A	INITIAL RELEASE	NOV-2016	M. BANCISOR
B	AS PER ECR-068314	NOV-2016	M. BANCISOR
C	AS PER ECR-070284	SEP-2017	M. BANCISOR

P.O SPEC.	BK/BD SPEC.	SOCKET OEM	OEM PART#	HANDLER

TEMPLATE ENGINEER N/A	DATE	<b>SCHEMATIC</b>	
HARDWARE SERVICES R. AMARILLE	NOV-2016		
HARDWARE SYSTEMS N/A			
TEST ENGINEER N/A			
COMPONENT ENGINEER G. CELEDONIO	NOV-2016	HW TYPE : Customer Evaluation Z	Product(s) : ad9963 : ad9963
TEST PROCESS N/A		PACKAGE : N/A-lead N/A N/A-family : Pitch-pitch Style Vendor Style	<User Define>
HARDWARE RELEASE R. AMARILLE	NOV-2016	<User Define>	<User Define>
DESIGNER M . JOSE	NOV-2016	MASTER PROJECT TEMPLATE TBD	TESTER TEMPLATE no_template
PTD ENGINEER M. BANCISOR	NOV-2016	DRAWING NO. <b>02_042233</b>	
CHECKER N/A		REV. <b>C</b>	
UNLESS OTHERWISE SPECIFIED DIMENSIONS ARE IN INCHES			
TOLERANCES		SIZE	SCALE
DECIMALS X.XX +0.010 X.XXX +0.005	FRACTIONS +1/32	ANGLES +2	CODE ID NO. CodeID
		<b>D</b>	1:1
SHEET 1			OF 18

REVISIONS			
REV	DESCRIPTION	DATE	APPROVED

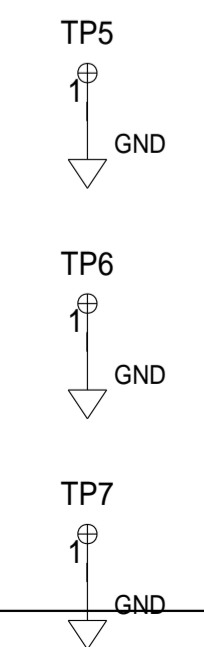
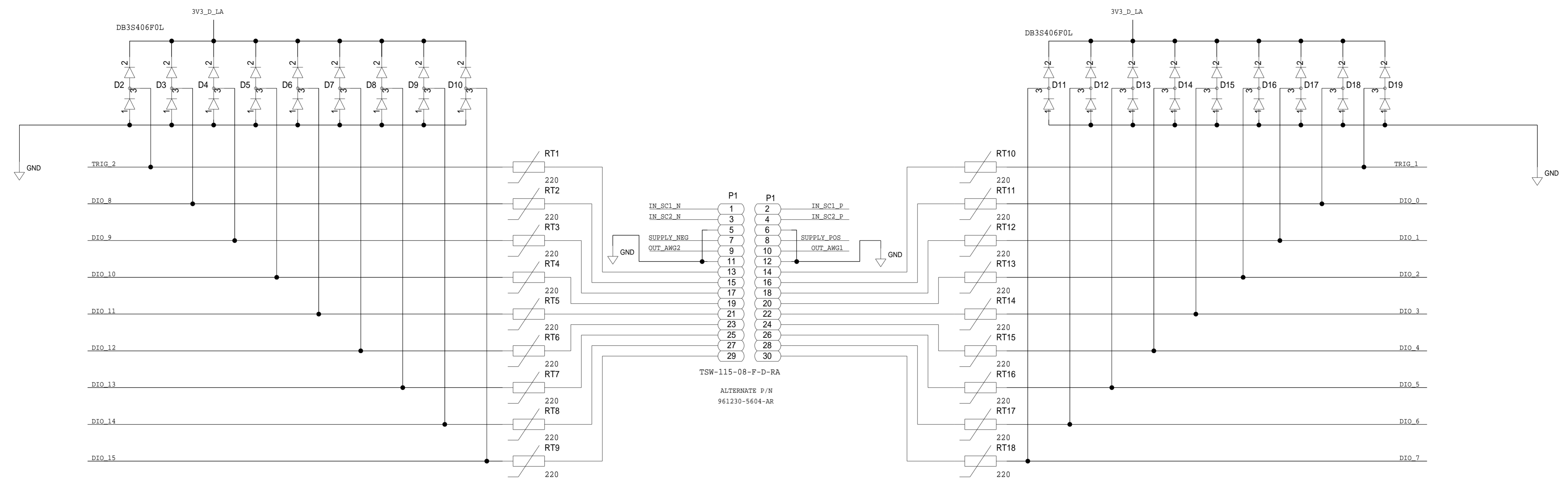

	<b>SCHEMATIC</b>		
	HW TYPE : Customer Evaluation Z Product(s) : ad9963 : ad9963		
	DESIGN VIEW <DESIGN_VIEW>	DRAWING NO. 02_042233	REV C
PTD ENGINEER M. BANCISOR	SIZE D	SCALE 1:1	SHEET 2 OF 18

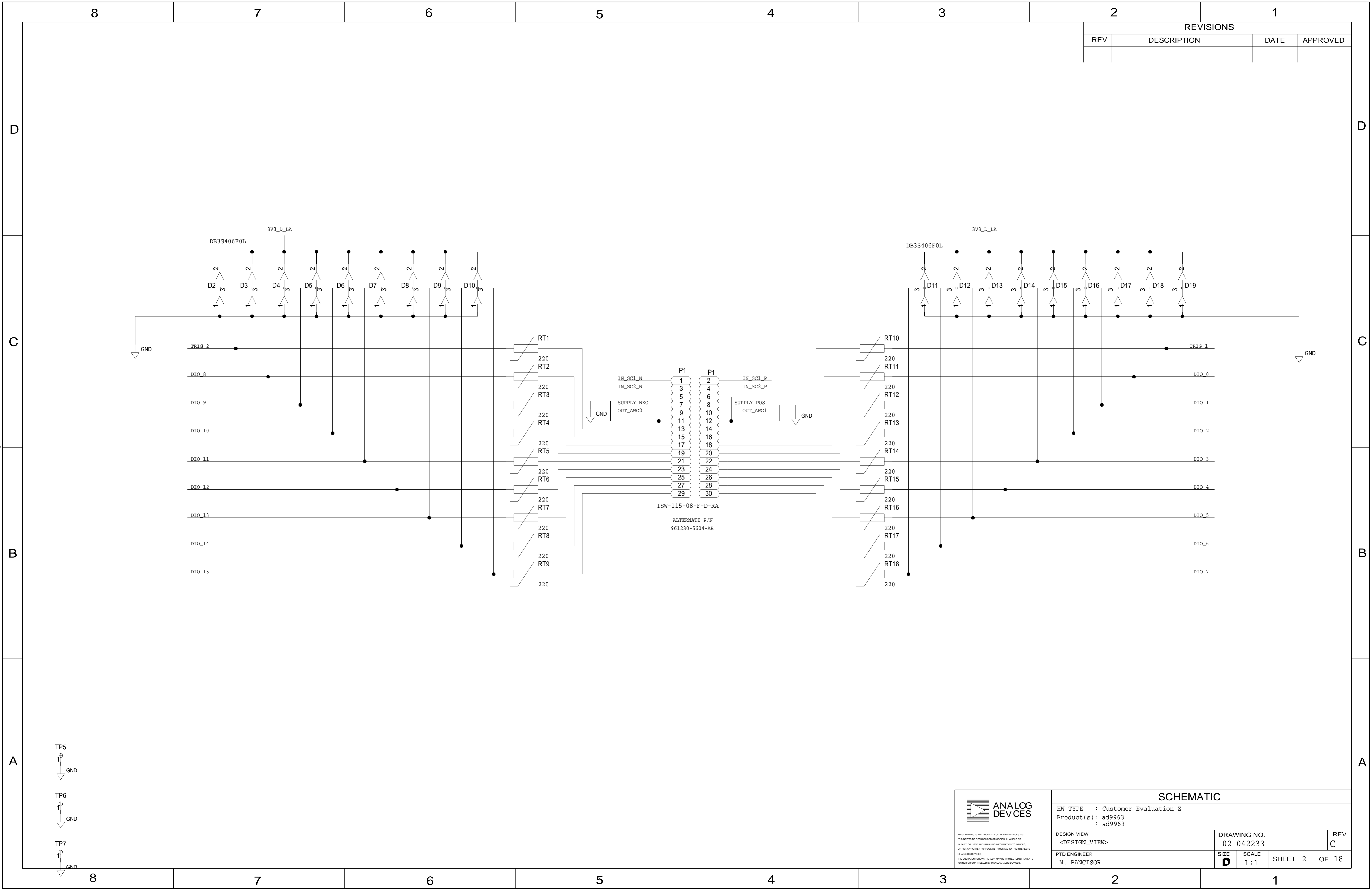

# ADC/DAC AD9963

REVISIONS			
REV	DESCRIPTION	DATE	APPROVED

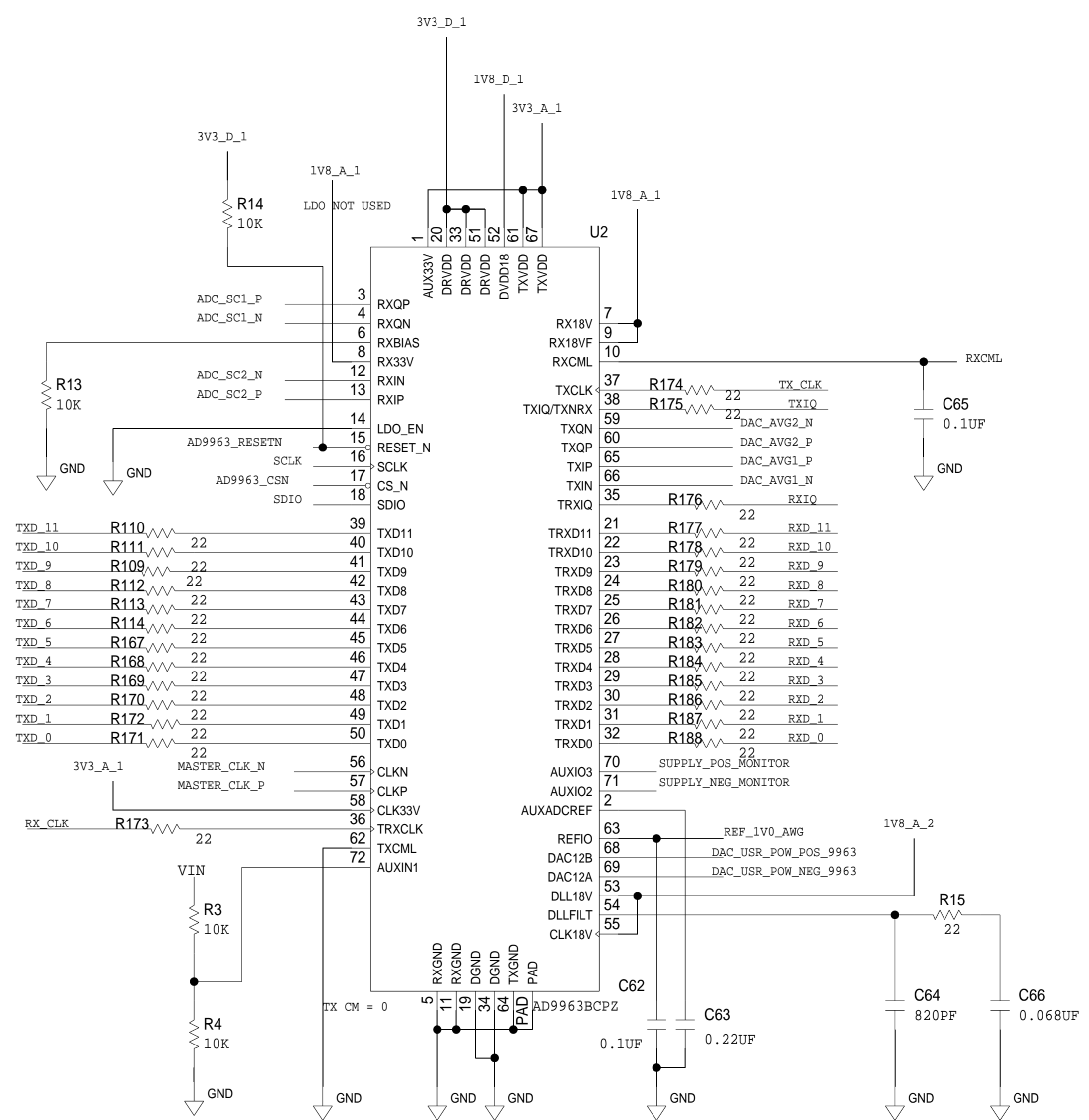
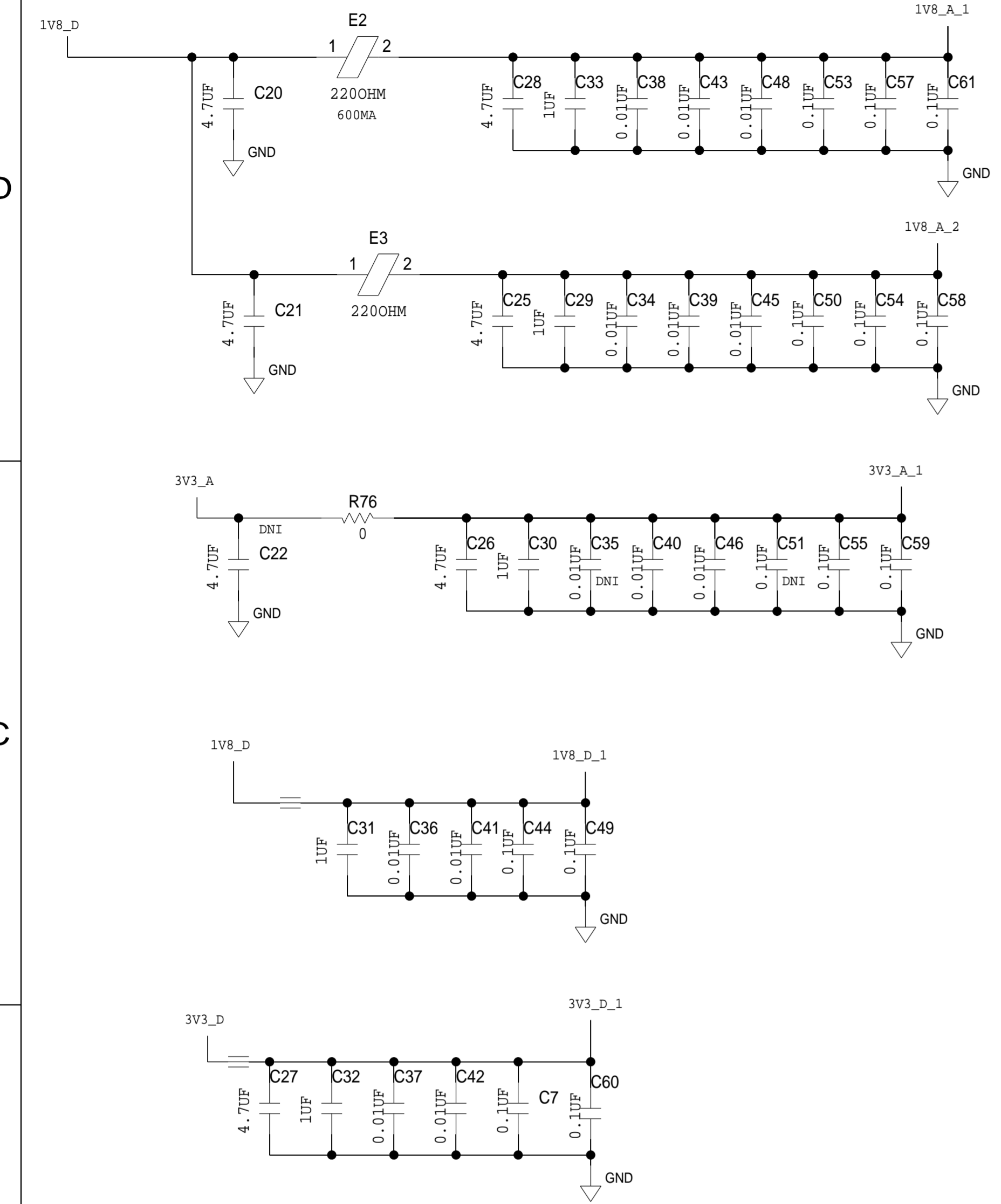

	<b>SCHEMATIC</b>		
	HW TYPE : Customer Evaluation Z Product(s) : ad9963 : ad9963		
DESIGN VIEW <DESIGN_VIEW>	DRAWING NO. 02_042233	REV C	
PTD ENGINEER M. BANCISOR	SIZE D	SCALE 1:1	SHEET 3 OF 18

THIS DRAWING IS THE PROPERTY OF ANALOG DEVICES INC. IT IS NOT TO BE REPRODUCED OR COPIED, IN WHOLE OR IN PART, OR USED IN FURNISHING INFORMATION TO OTHERS, OR FOR ANY OTHER PURPOSE DETRIMENTAL TO THE INTERESTS OF ANALOG DEVICES. THE EQUIPMENT SHOWN HEREIN MAY BE PROTECTED BY PATENTS OWNED OR CONTROLLED BY ANALOG DEVICES.

REVISIONS			
REV	DESCRIPTION	DATE	APPROVED

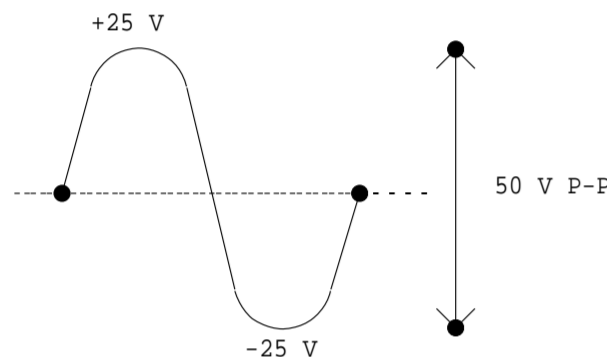
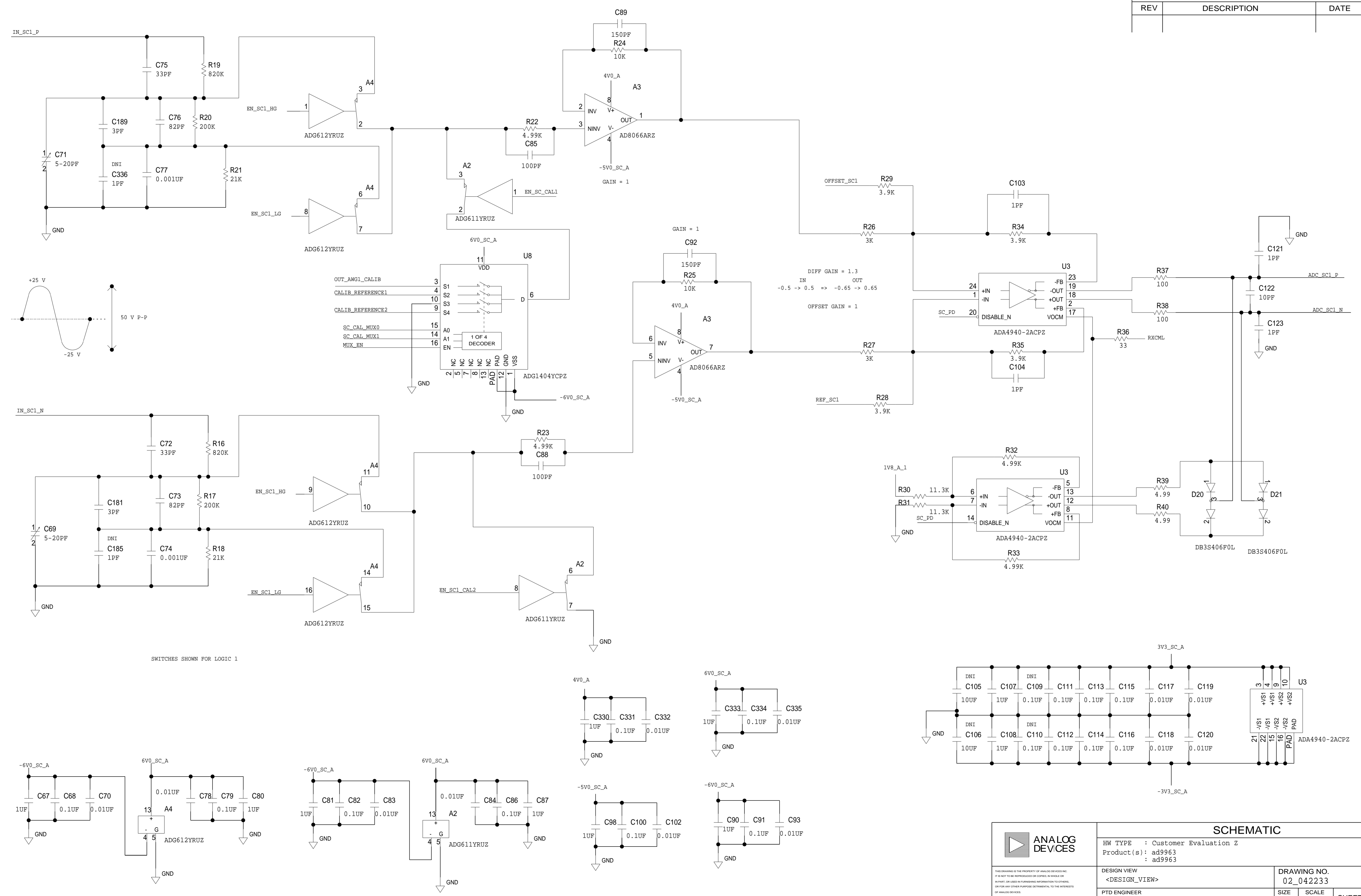

SWITCHES SHOWN FOR LOGIC 1

	<b>SCHEMATIC</b>		
	HW TYPE : Customer Evaluation Z Product(s) : ad9963 : ad9963		
DESIGN VIEW <DESIGN_VIEW>	DRAWING NO. 02_042233	REV C	
PTD ENGINEER M. BANCISOR	SIZE D	SCALE 1:1	SHEET 4 OF 18

REVISIONS			
REV	DESCRIPTION	DATE	APPROVED

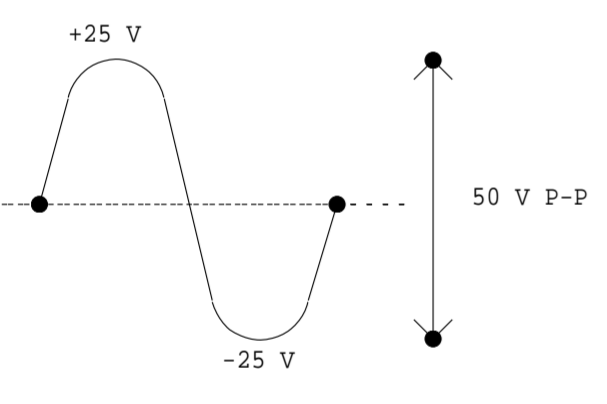
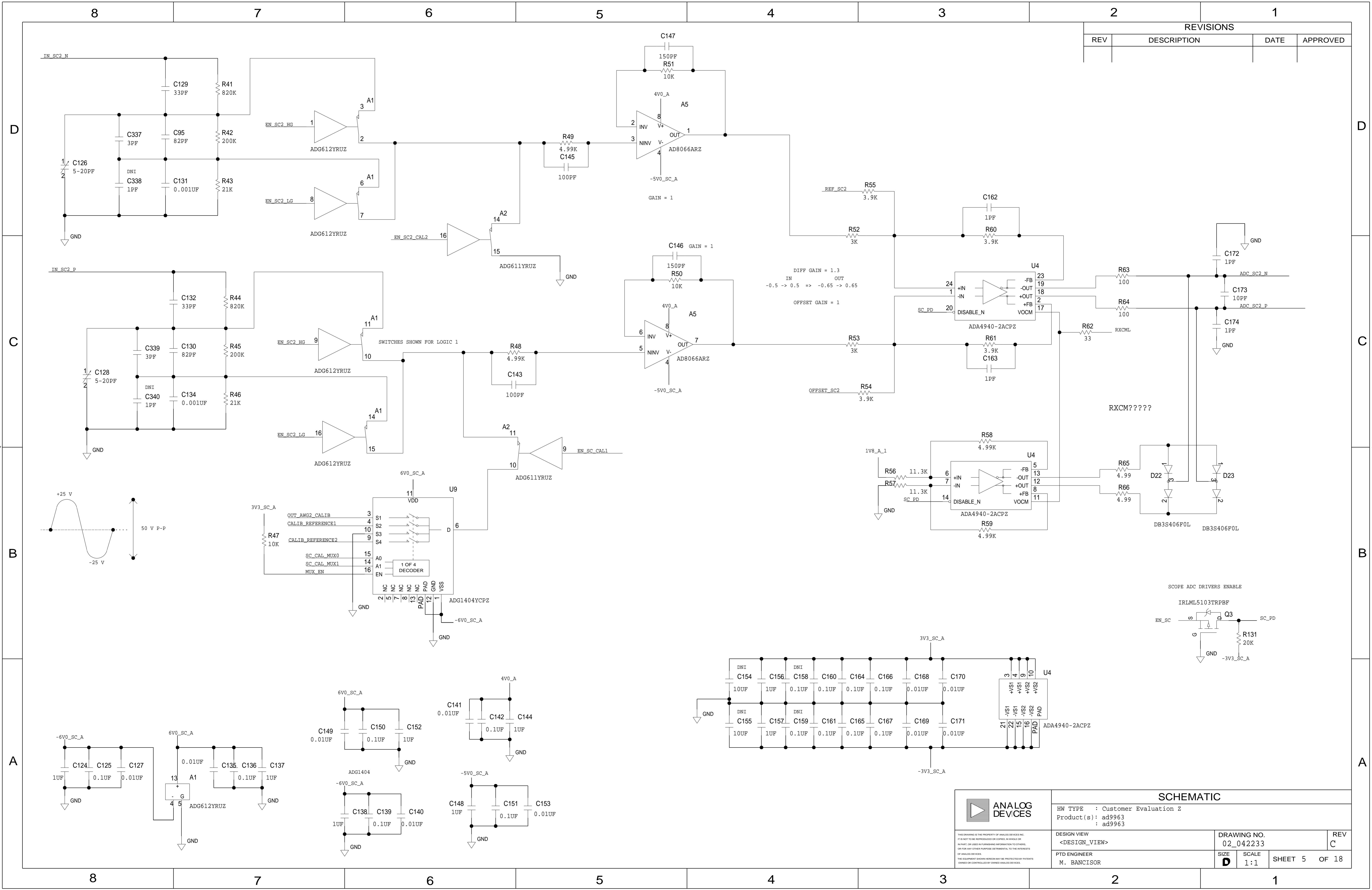

ANALOG DEVICES			
HW TYPE : Customer Evaluation Z Product(s) : ad9963 : ad9963		<b>SCHEMATIC</b>	
DESIGN VIEW <DESIGN_VIEW>	DRAWING NO. 02_042233	REV C	
PTD ENGINEER M. BANCISOR	SIZE D	SCALE 1:1	SHEET 5 OF 18

# AWG FRONT END

REVISIONS			
REV	DESCRIPTION	DATE	APPROVED

## CURRENT->VOLTAGE

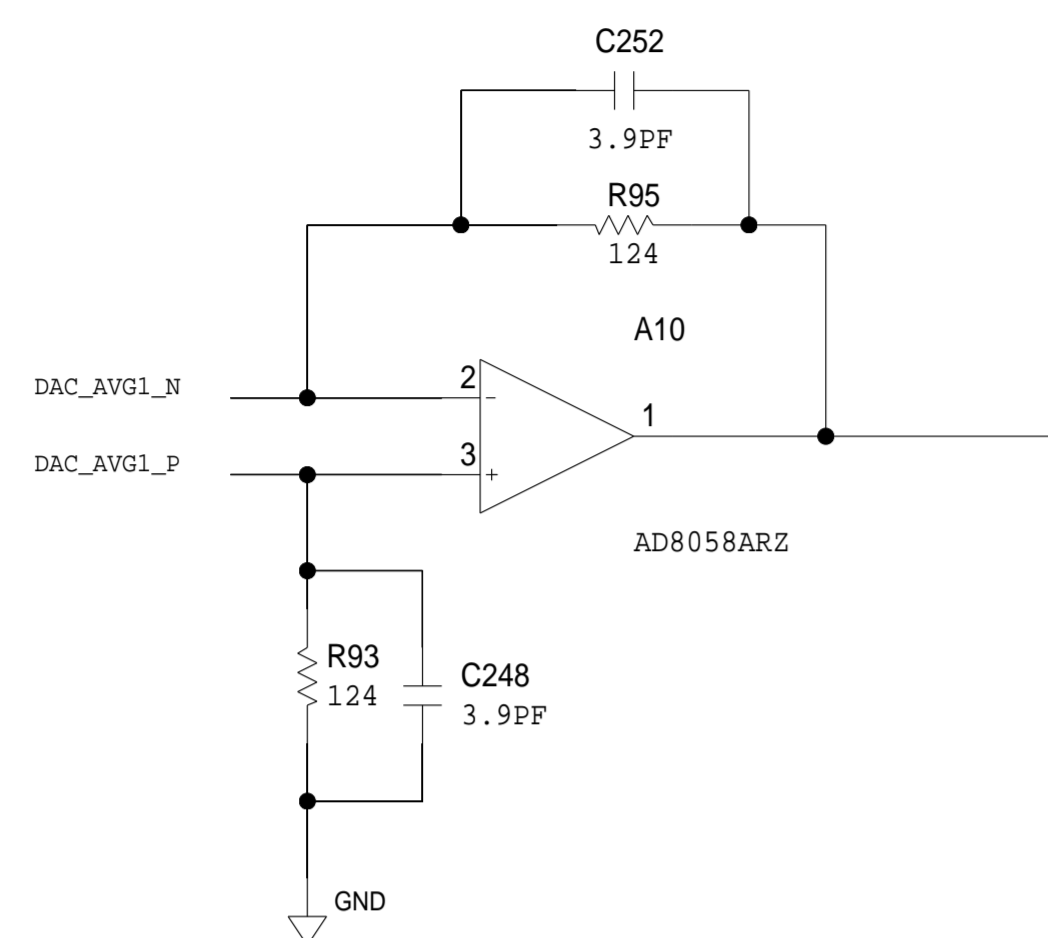

## GAIN + OFFSET

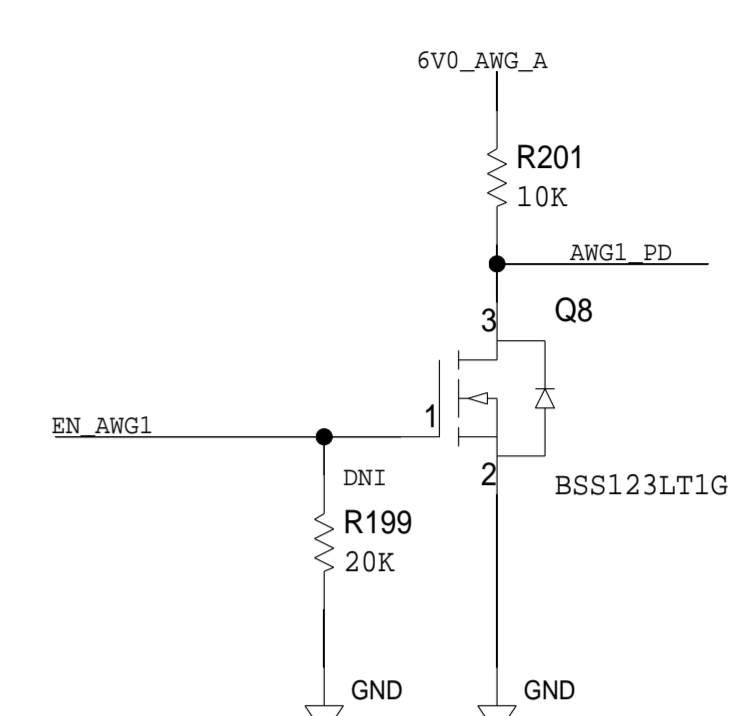
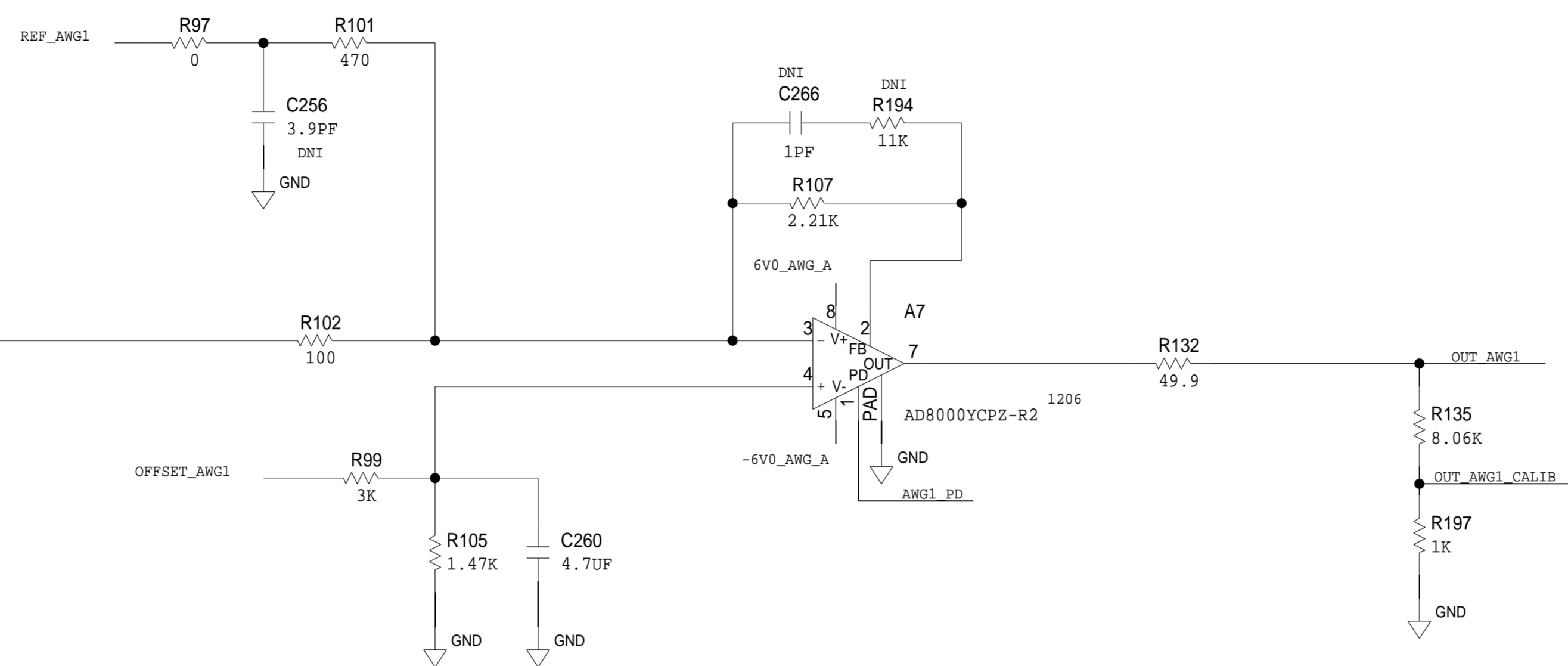

IN            OUT  
 4MA FS => -0.496 -> 0.496  
 1MA FS => -0.124 -> 0.124

SIGNAL GAIN = -11  
 IN            OUT  
 -0.496 -> 0.496 => 5.456 -> -5.456  
 -0.124 -> 0.124 => 1.364 -> -1.364

REF GAIN = -4.583  
 OFFSET GAIN = 9.075  
 IN            OUT  
 0 -> 1.2 => -5.5 -> 5.5

## CURRENT->VOLTAGE

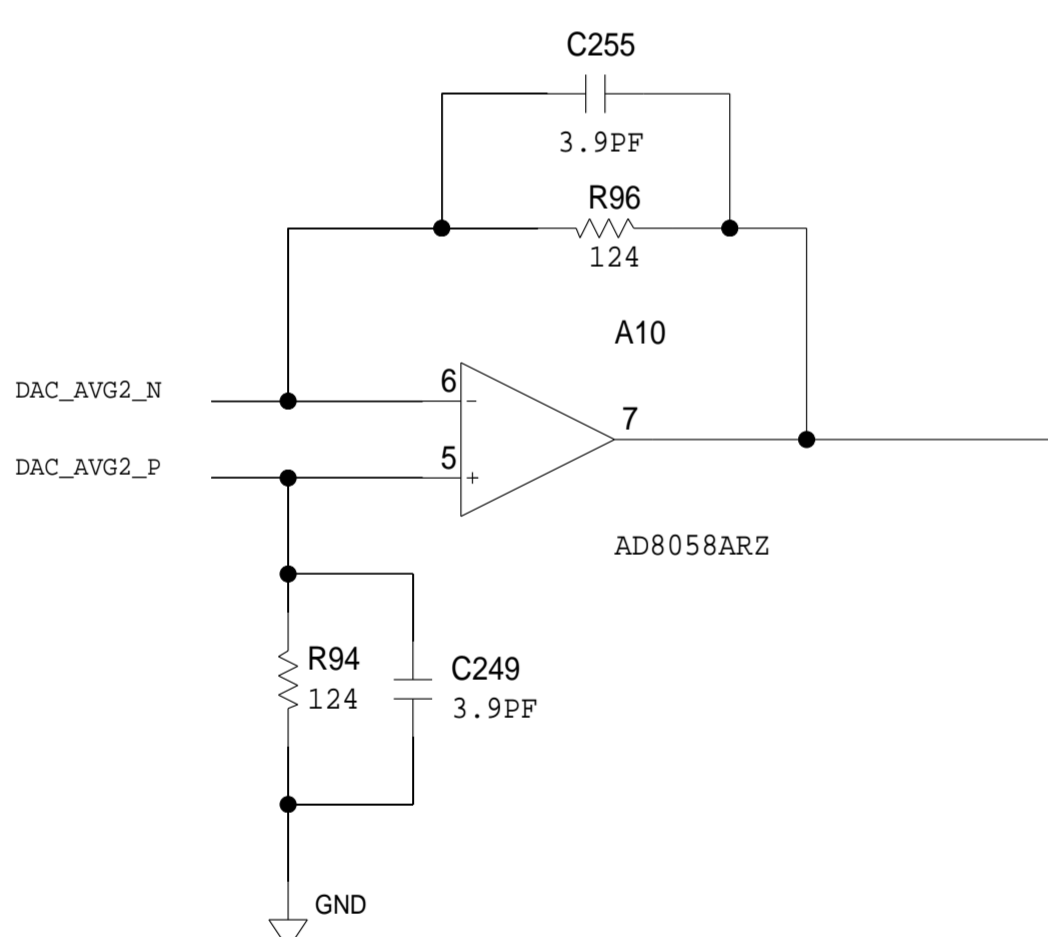

## GAIN + OFFSET

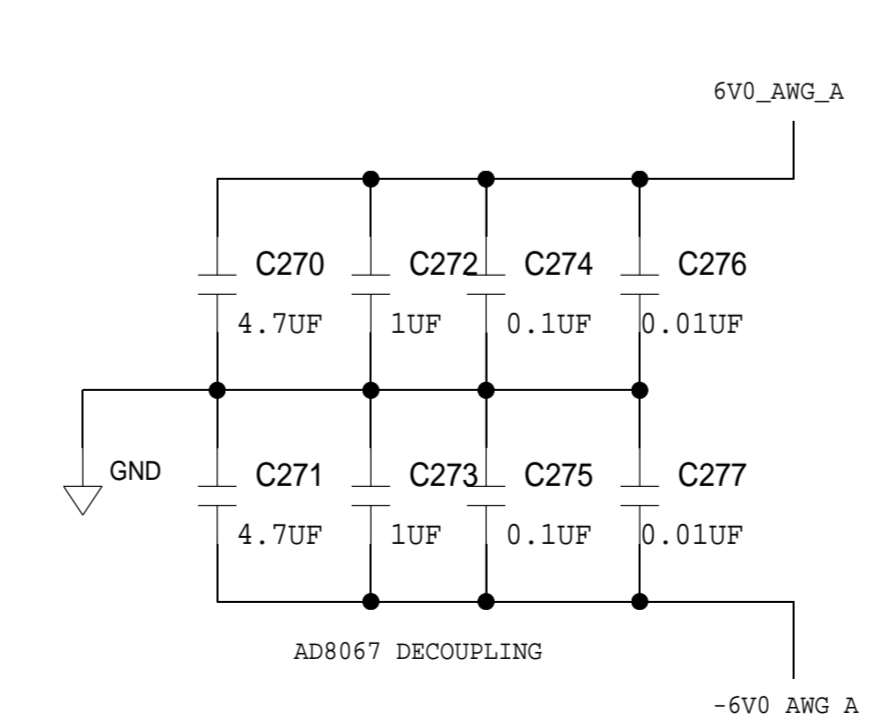
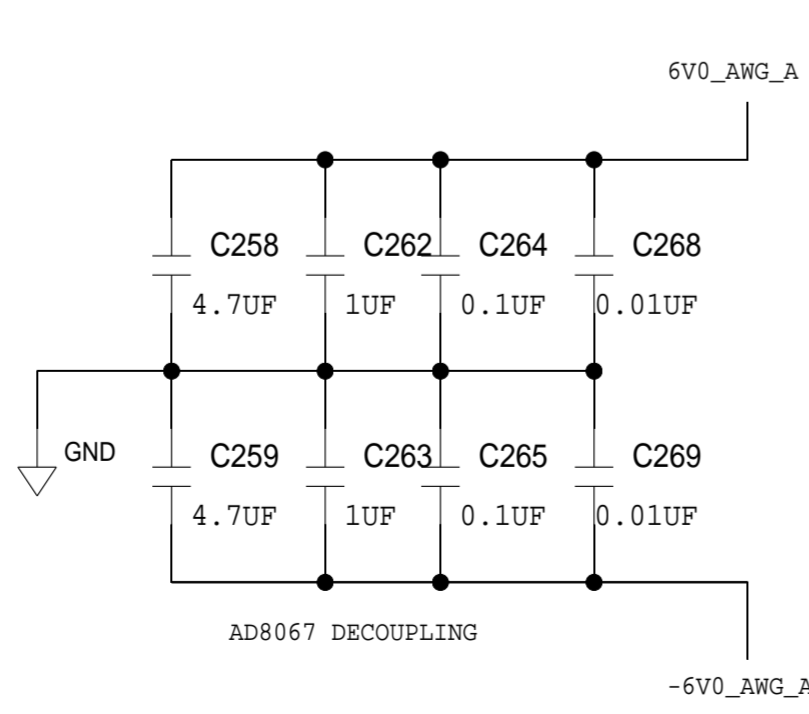
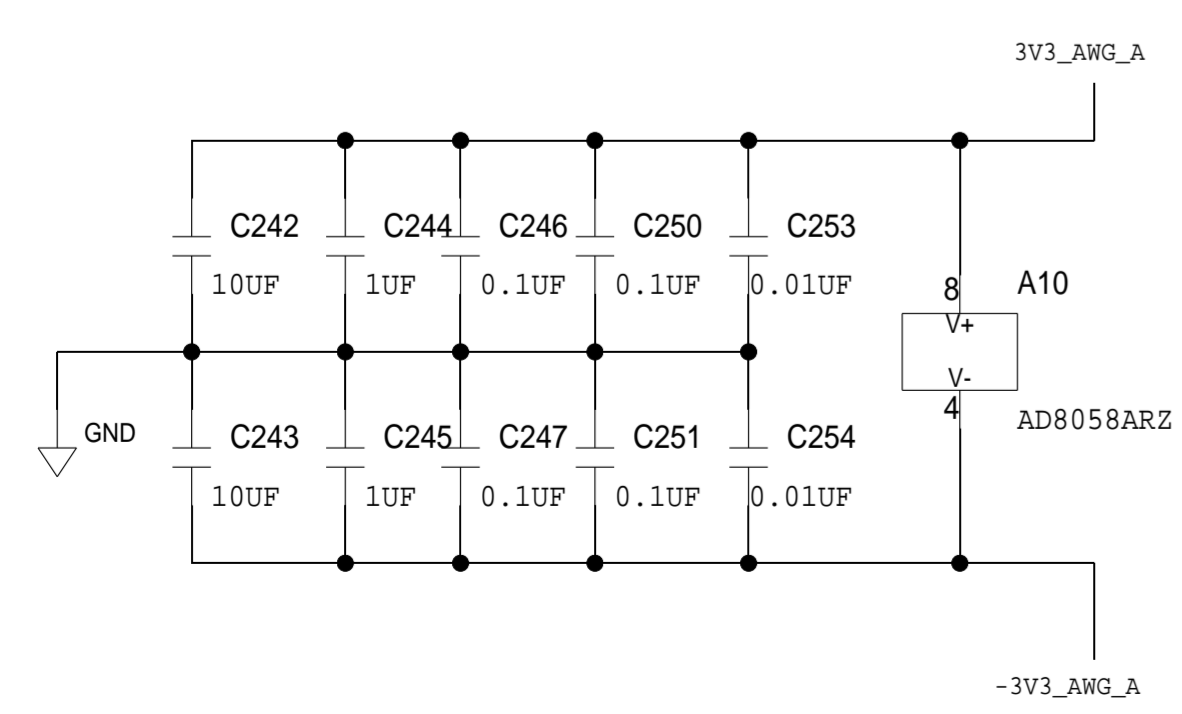
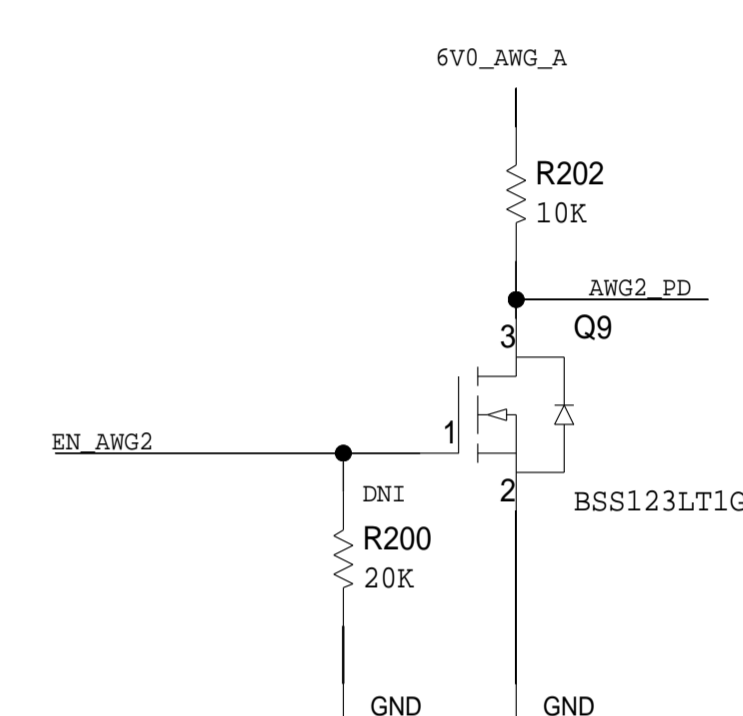
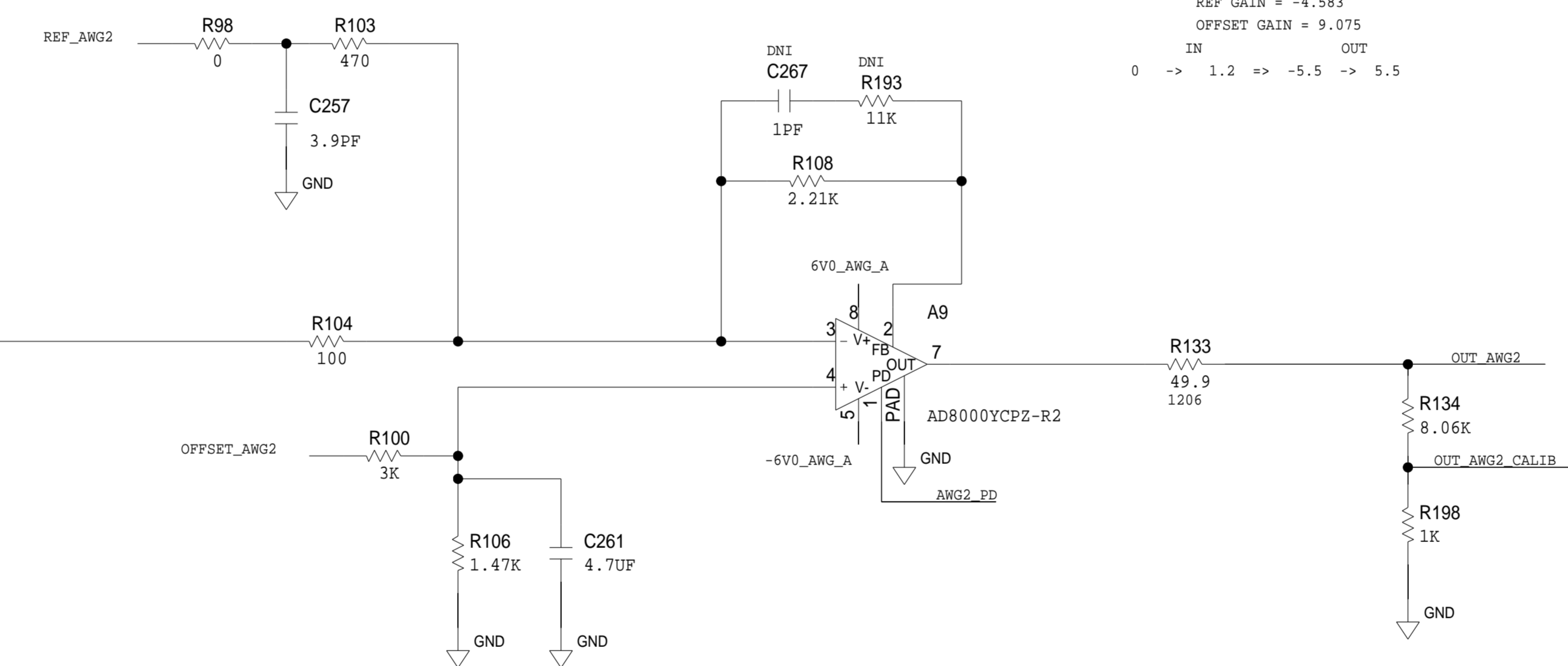

	<b>SCHEMATIC</b>		
	HW TYPE : Customer Evaluation Z Product(s) : ad9963 : ad9963		
	DESIGN VIEW <DESIGN_VIEW>	DRAWING NO. 02_042233	REV C
	PTD ENGINEER M. BANCISOR	SIZE D	SCALE 1:1
		SHEET 6 OF 18	

# REFERENCES AND OFFSET

REVISIONS			
REV	DESCRIPTION	DATE	APPROVED

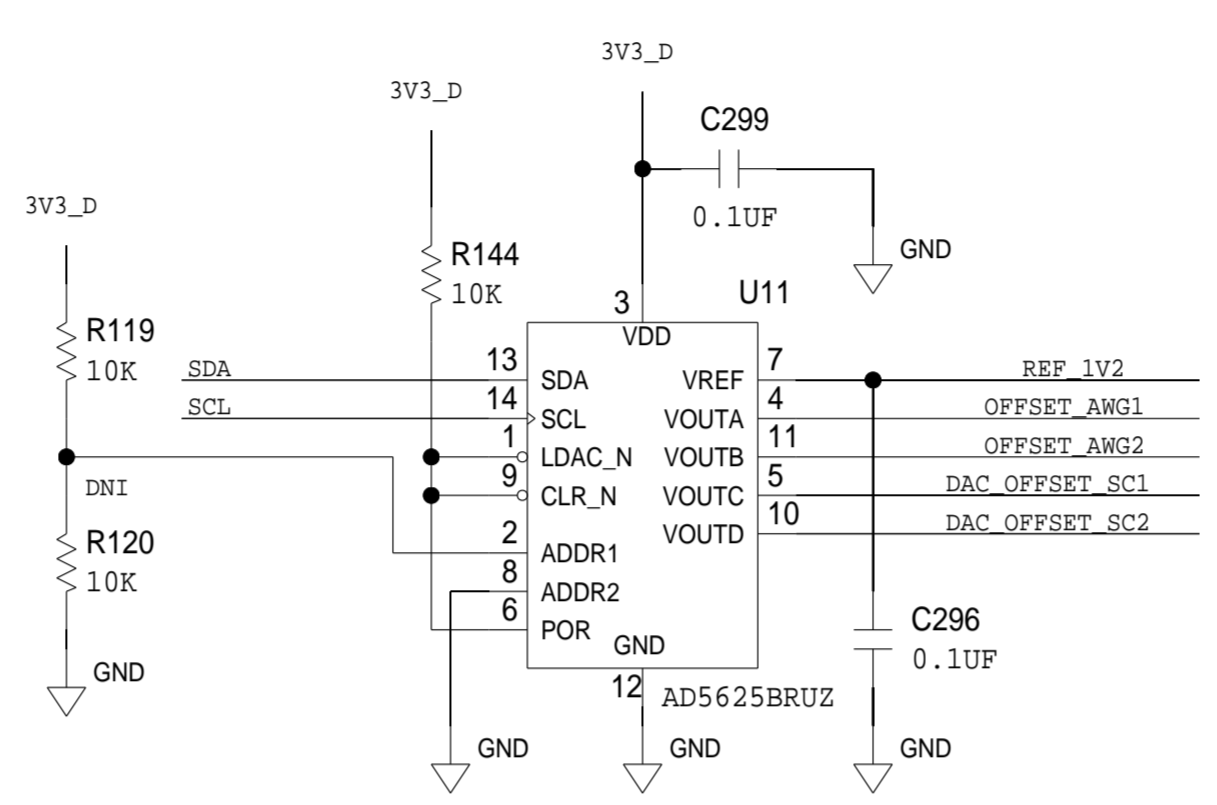
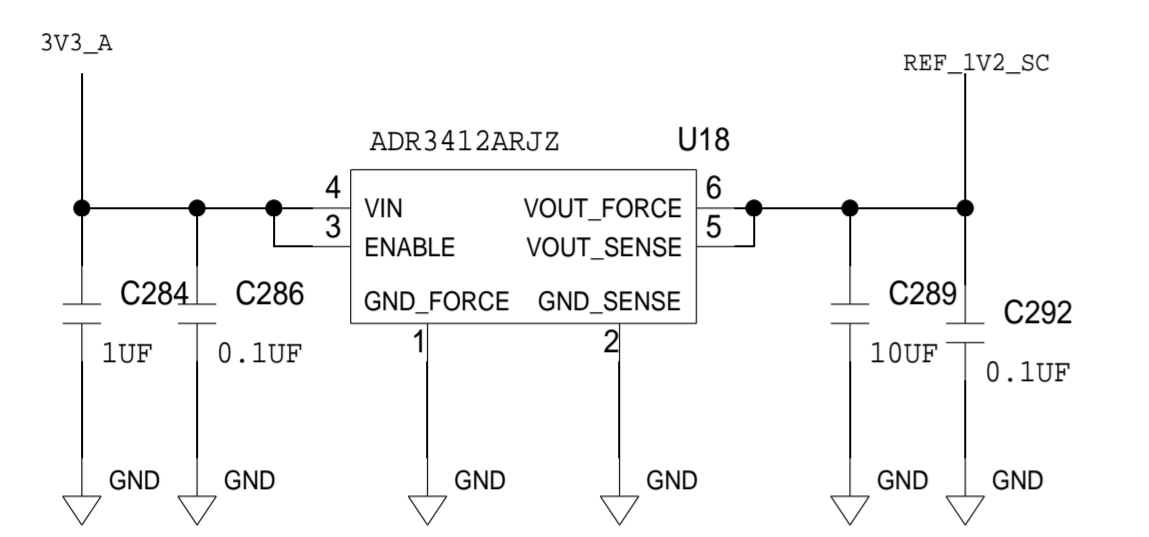
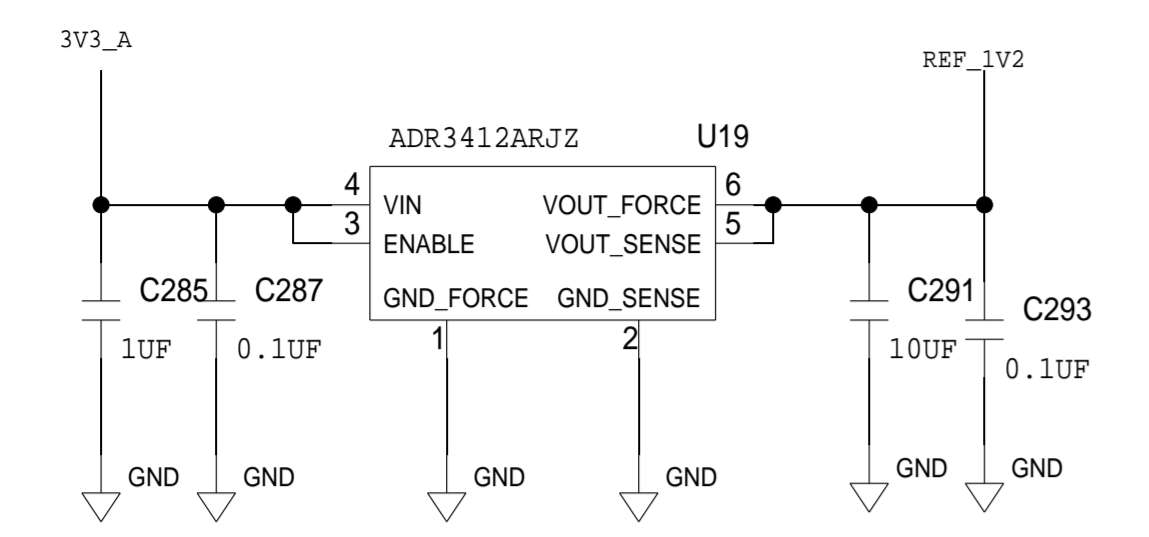

SIGNAL GAIN = 2.693  
IN 0 -> 1.2 => 0 -> 3.23

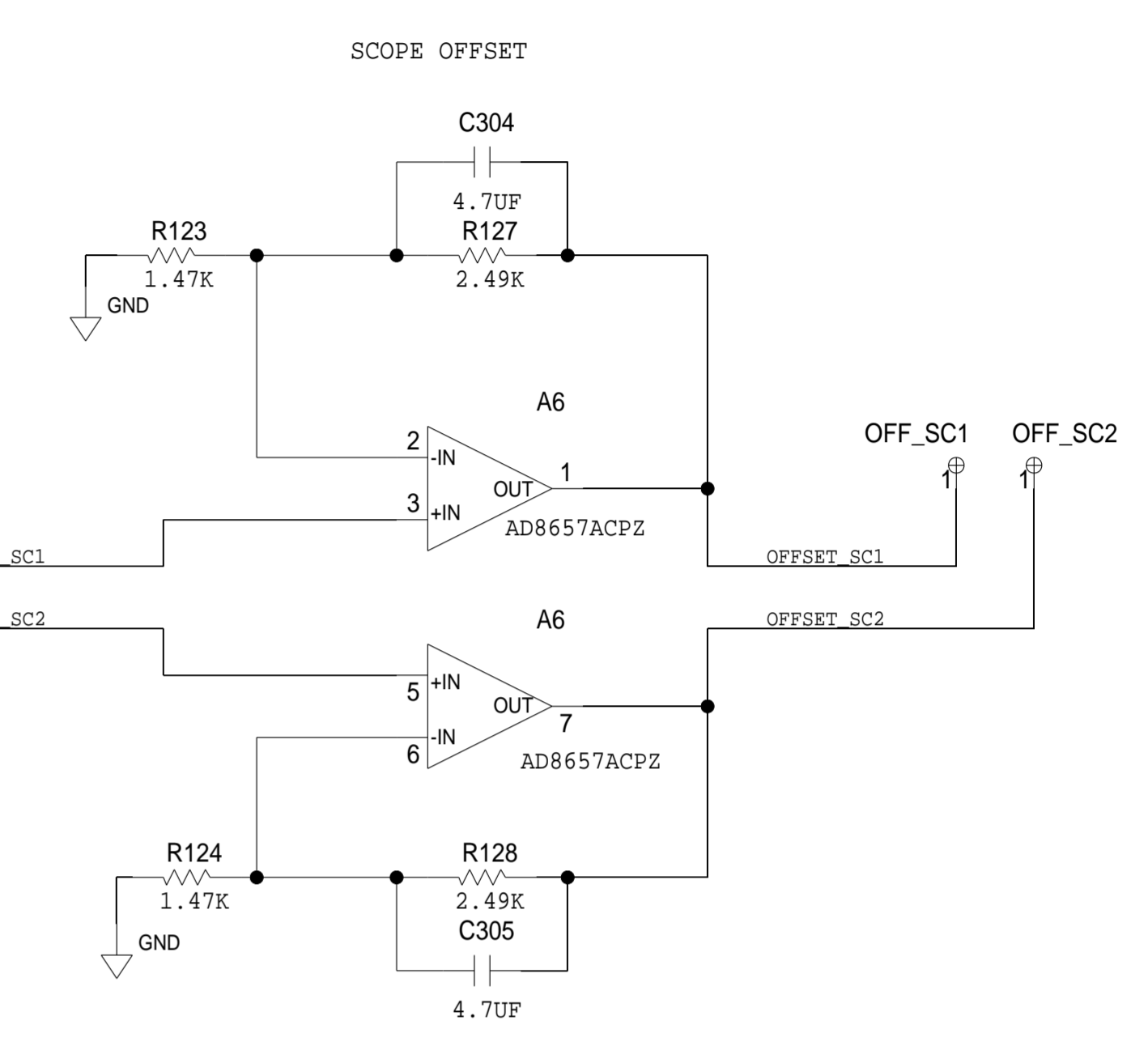

## DAC REFERENCE

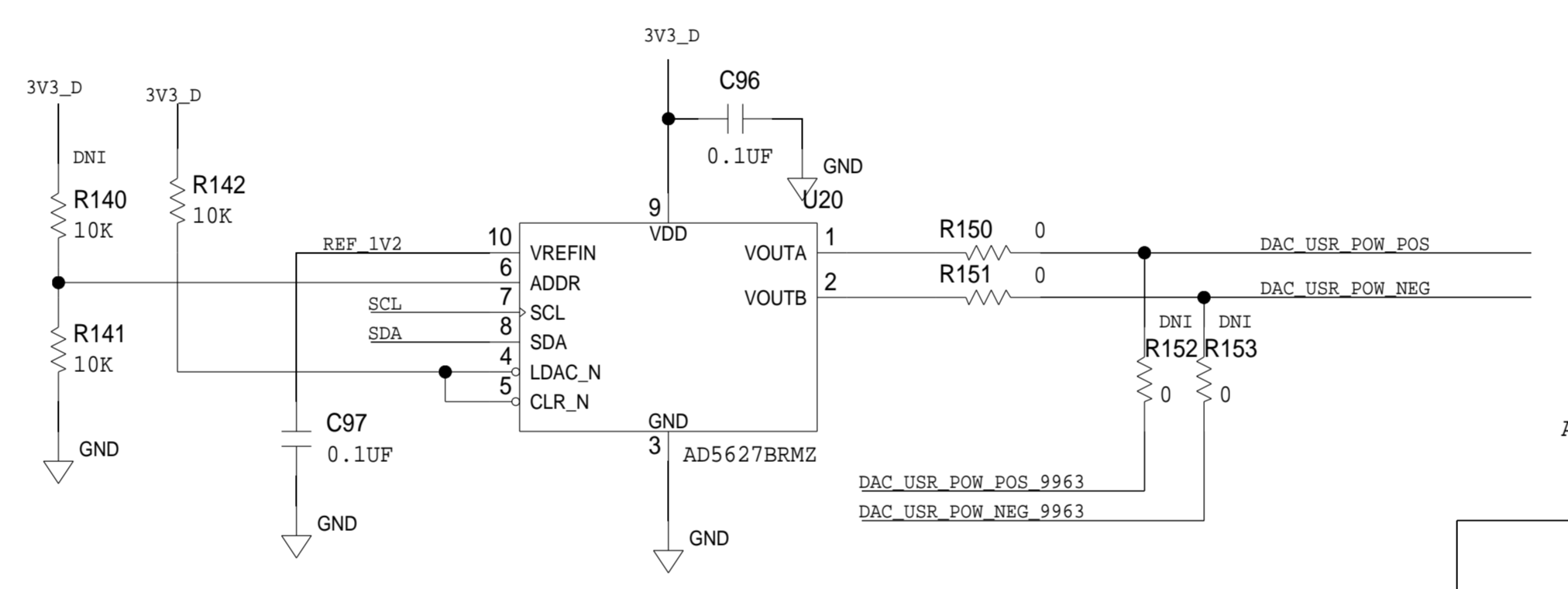
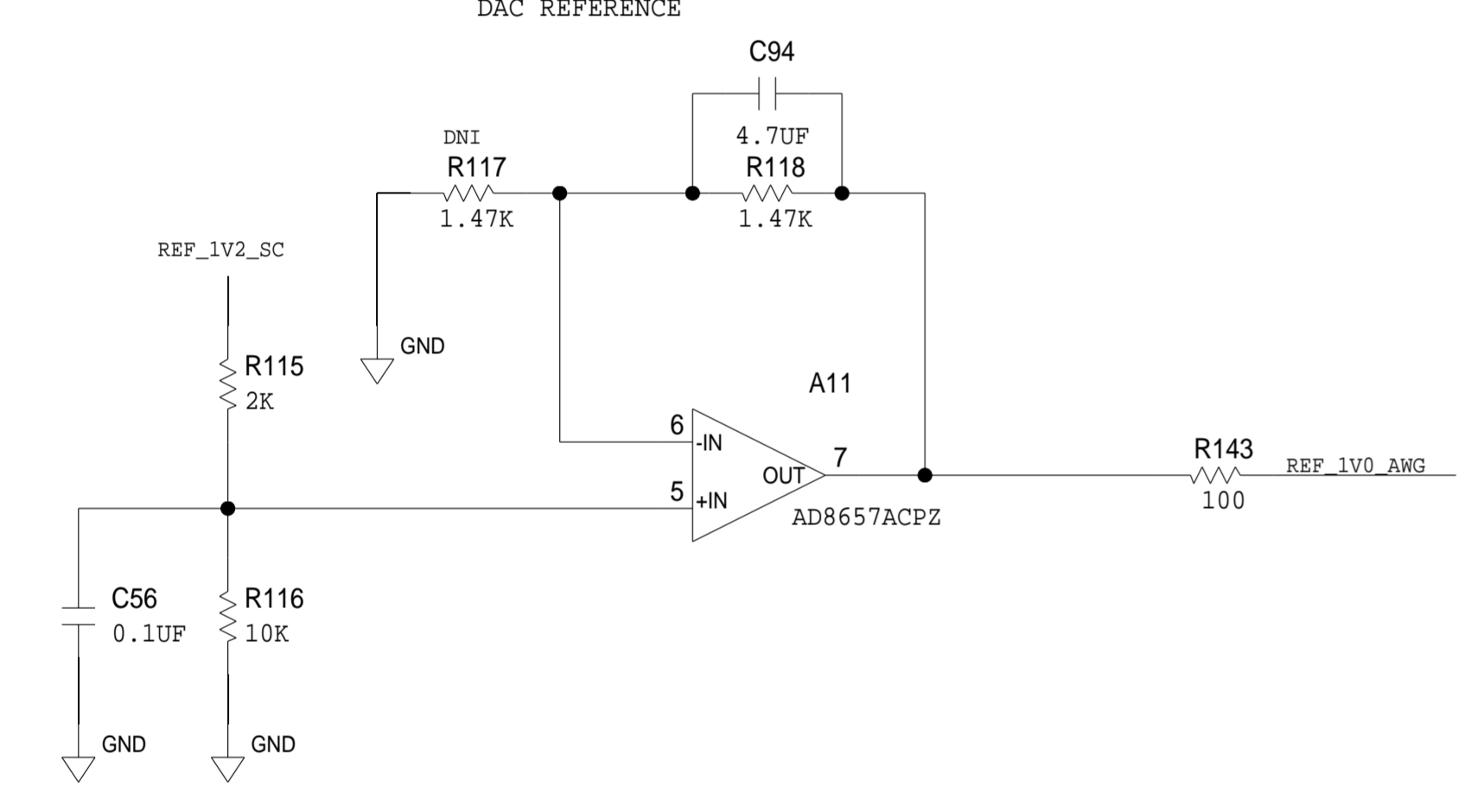

## AWG REFERENCE

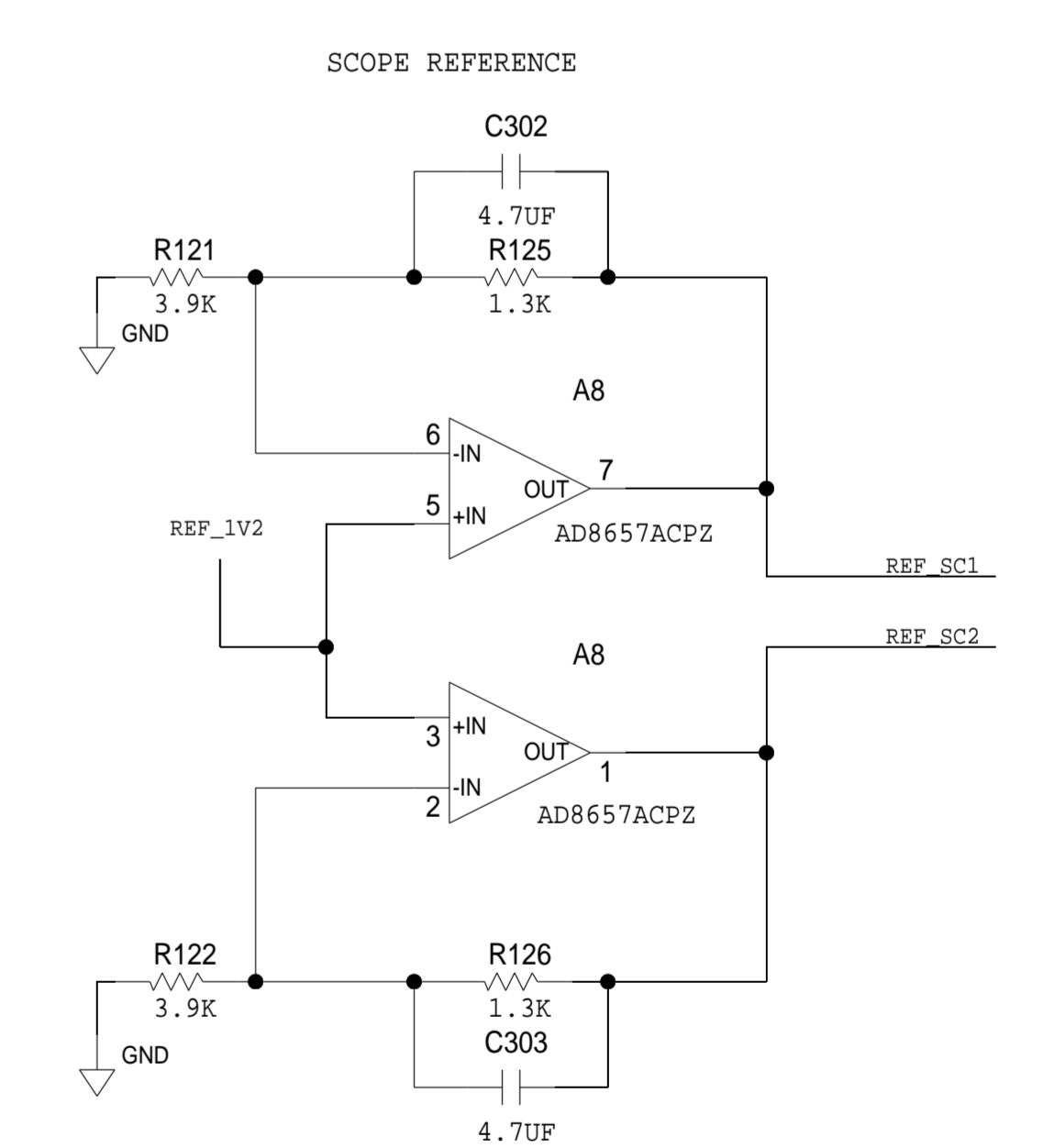
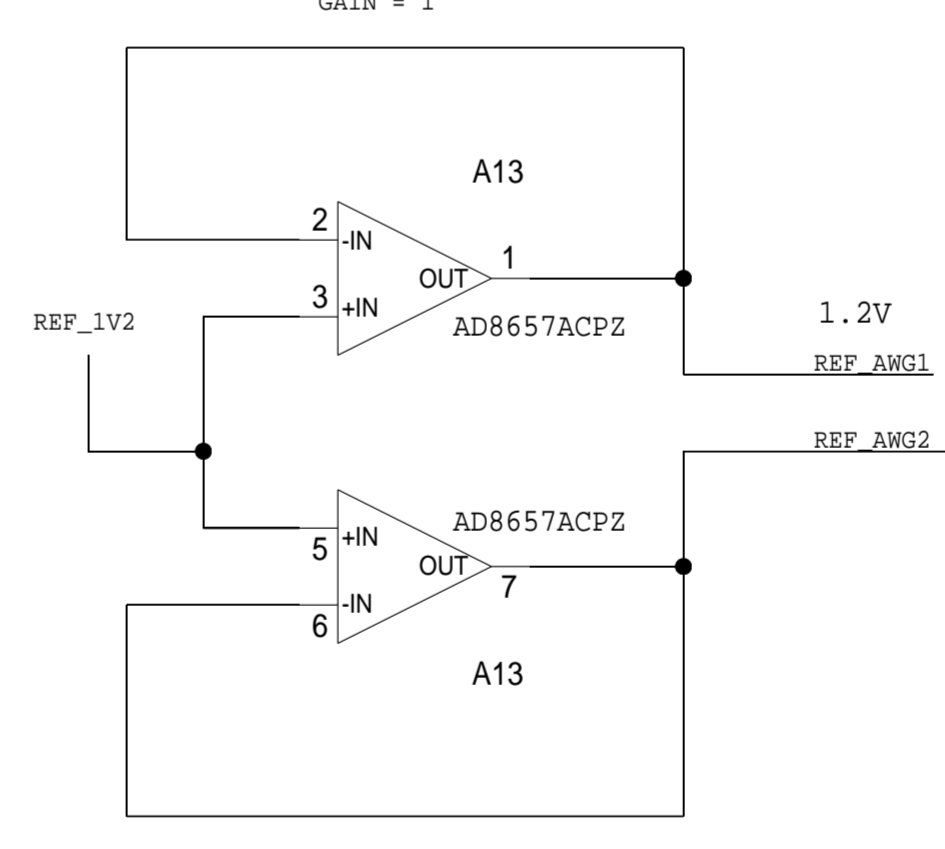

SIGNAL GAIN = 1.333  
IN 1.2 => 1.6

## SCOPE CALIBRATION VOLTAGES

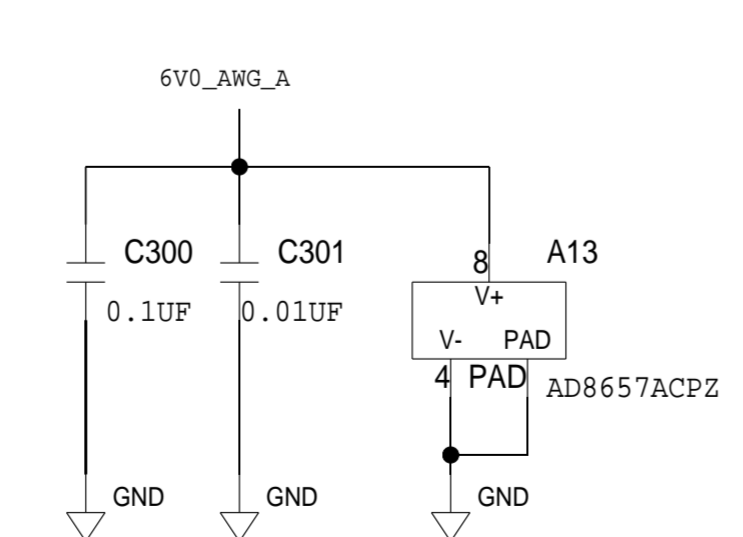
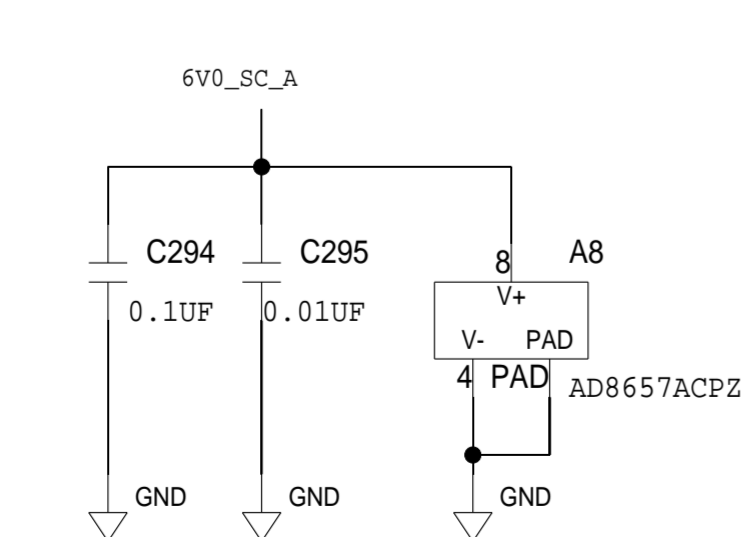
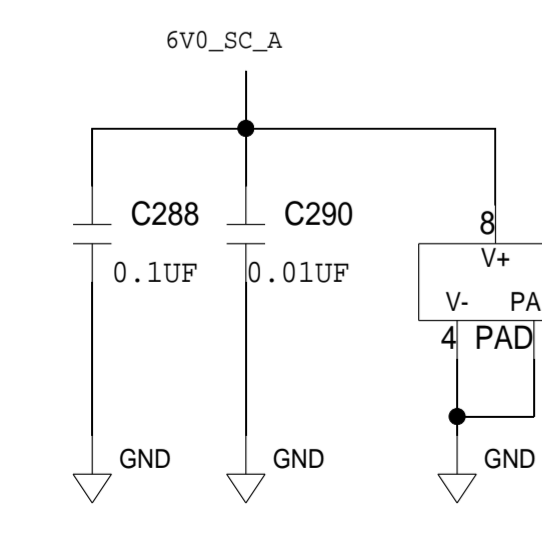
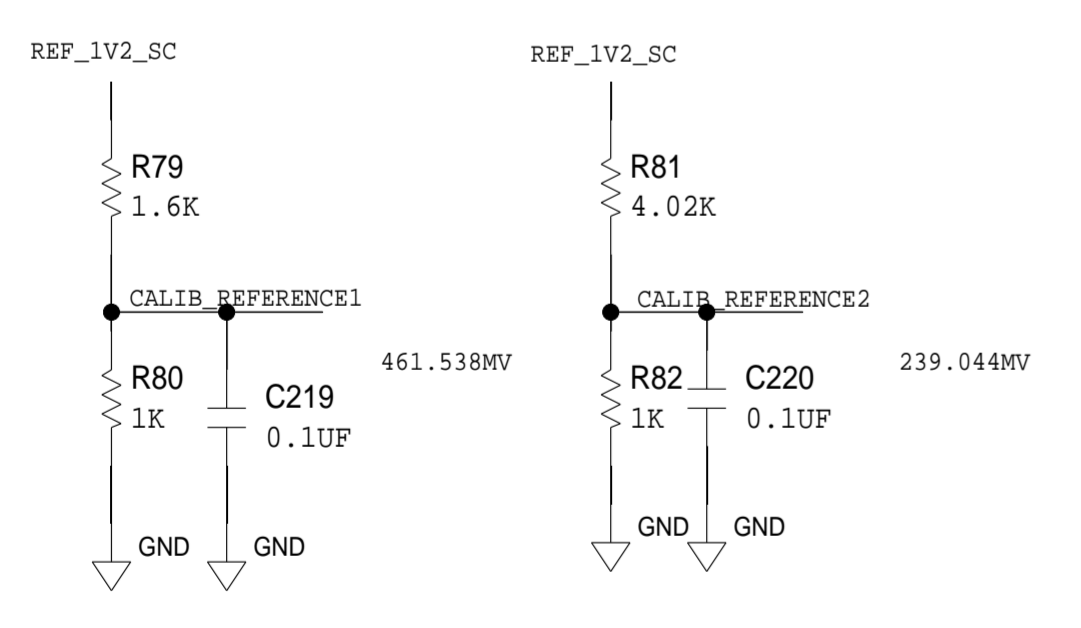

SCHEMATIC			
ANALOG DEVICES		HW TYPE : Customer Evaluation Z	
Product(s) : ad9963		Product(s) : ad9963	
DESIGN VIEW	<DESIGN_VIEW>	DRAWING NO.	02_042233
PTD ENGINEER	M. BANCISOR	REV	C
SIZE	D	SCALE	1:1
SHEET 7		OF 18	

ADA4051 DECOUPLING

ADA4051 DECOUPLING

REVISIONS			
REV	DESCRIPTION	DATE	APPROVED

# USER POWER SUPPLIES

PULLING THE SHUTDOWN PIN TO >1 V BELOW MIDSUPPLY TURNS THE DEVICE OFF

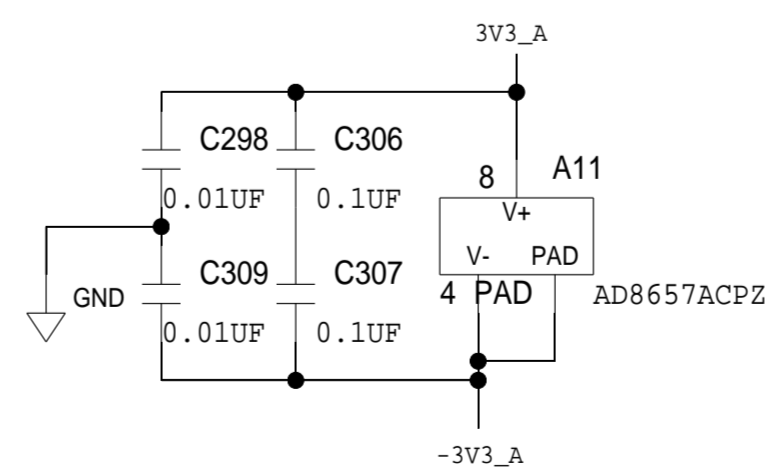
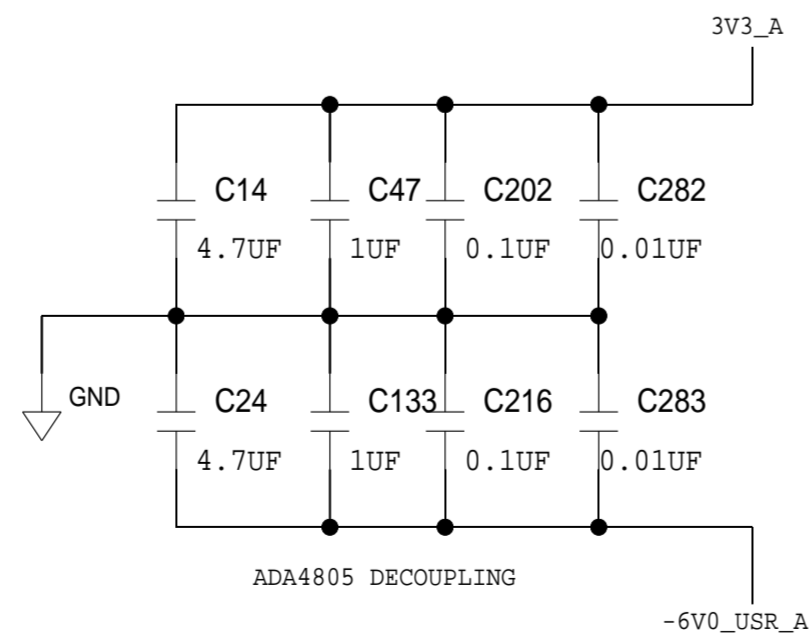
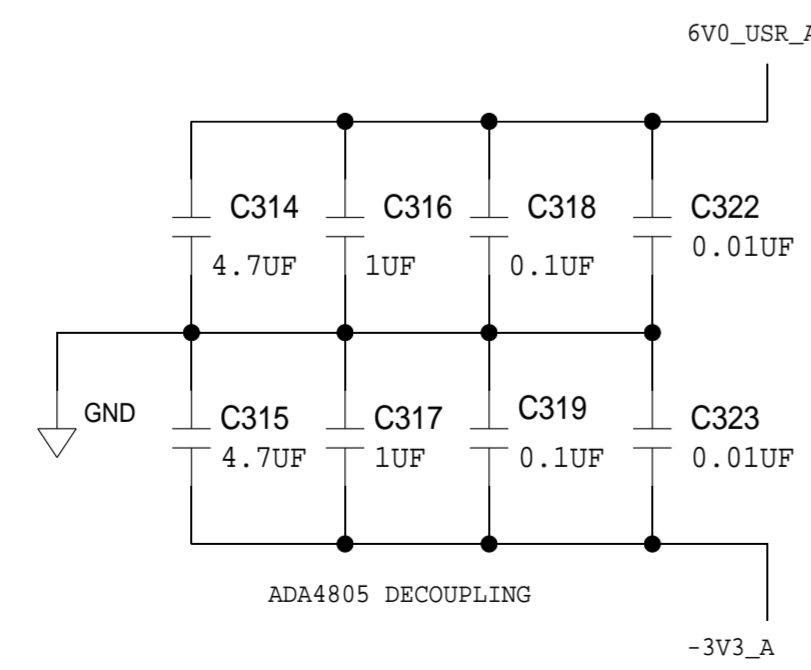
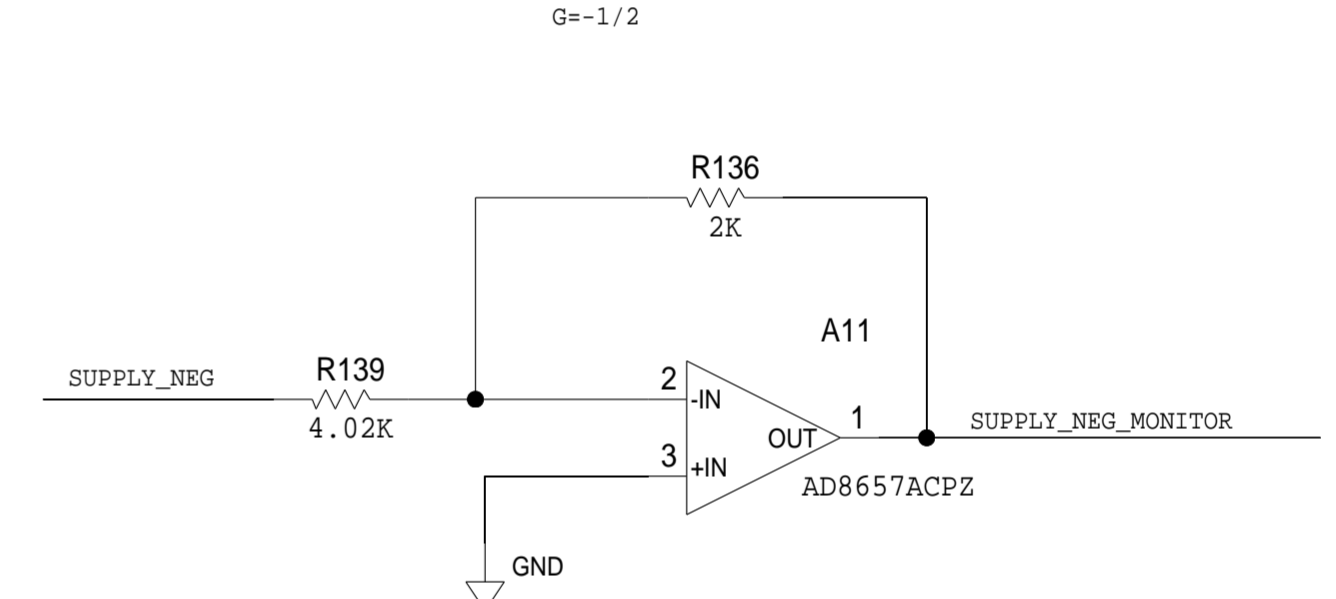
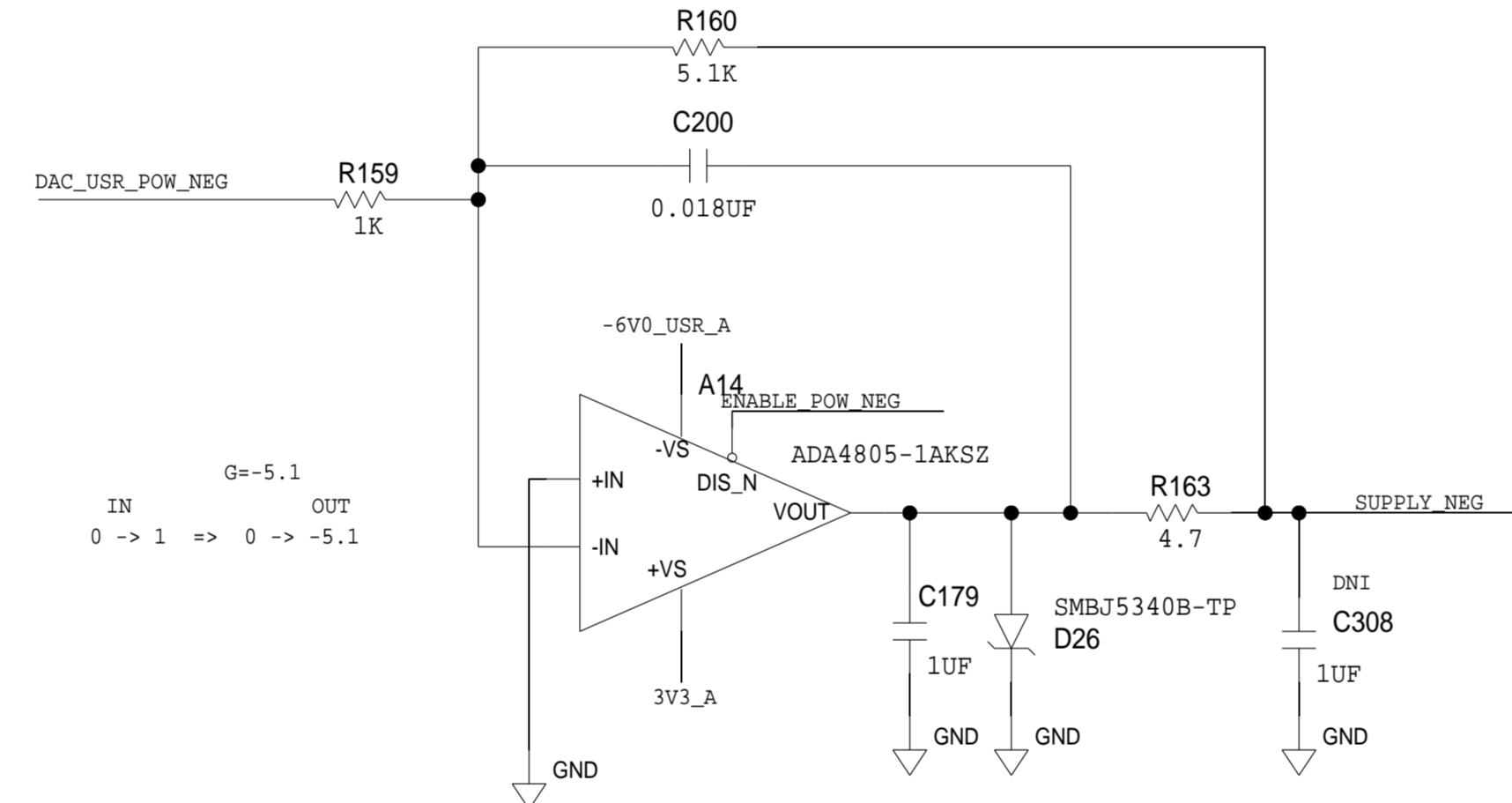
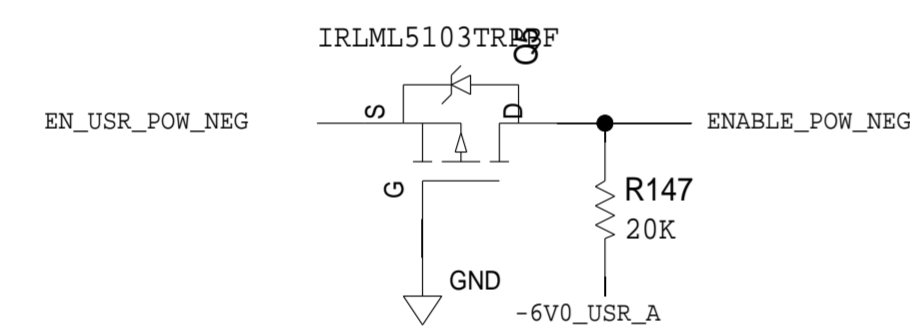
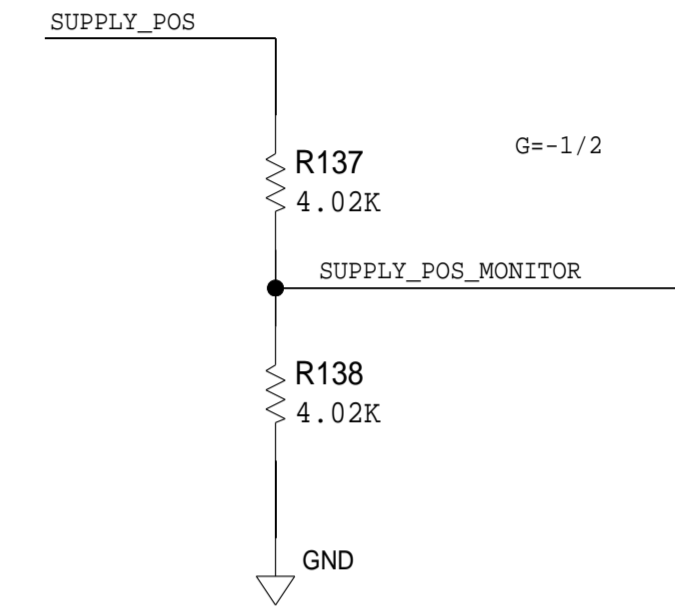
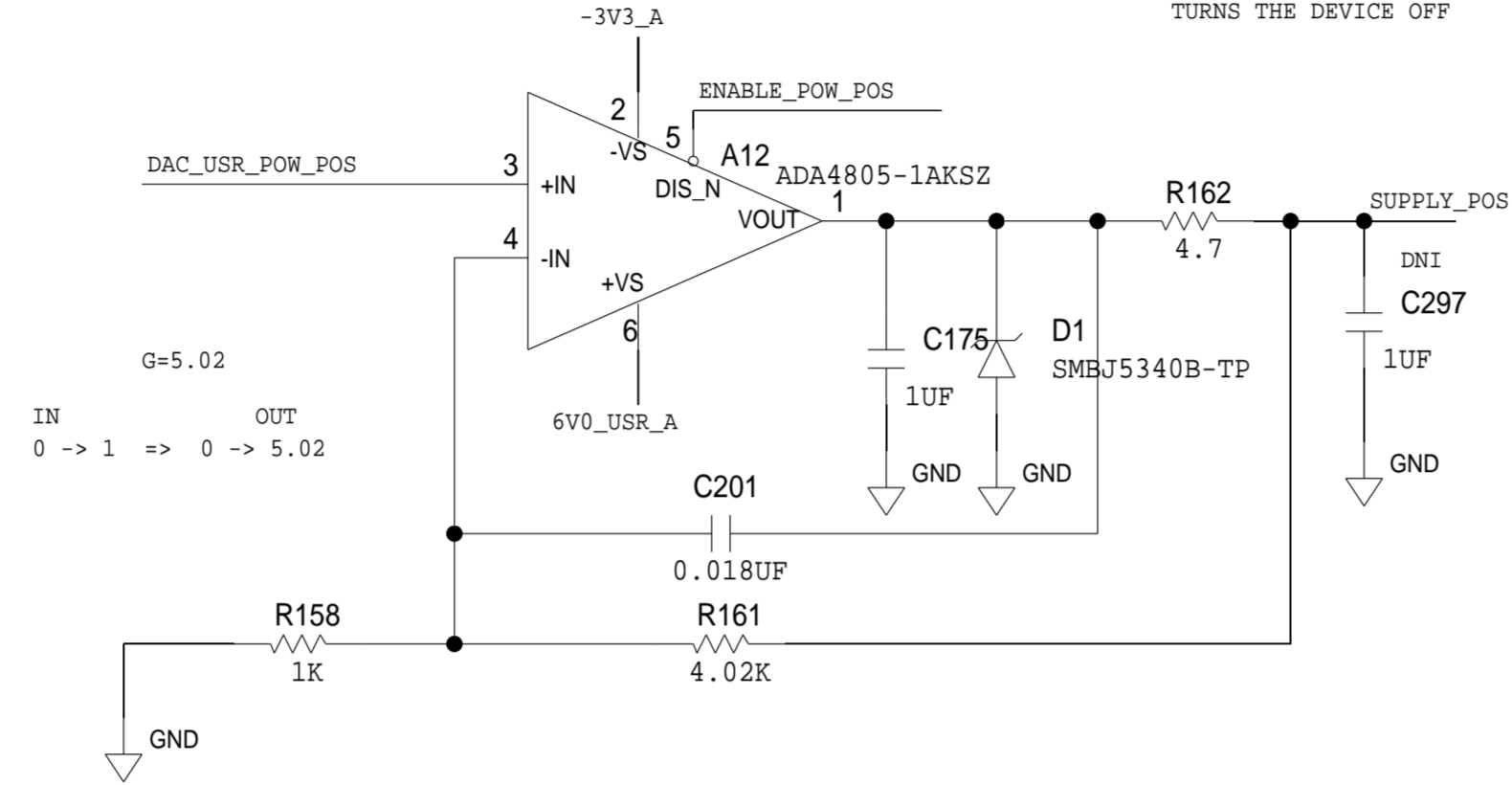
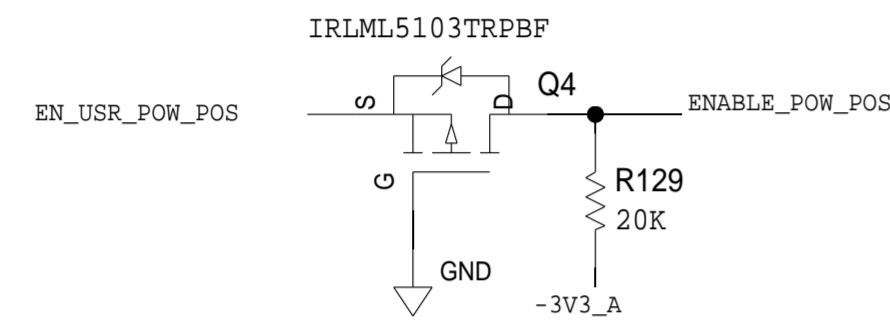

	<b>SCHEMATIC</b>		
	HW TYPE : Customer Evaluation Z Product(s) : ad9963 : ad9963		
	DESIGN VIEW <DESIGN_VIEW>	DRAWING NO. 02_042233	REV C
	PTD ENGINEER M. BANCISOR	SIZE D	SCALE 1:1
		SHEET 8 OF 18	



REVISIONS			
REV	DESCRIPTION	DATE	APPROVED

# CLOCKING

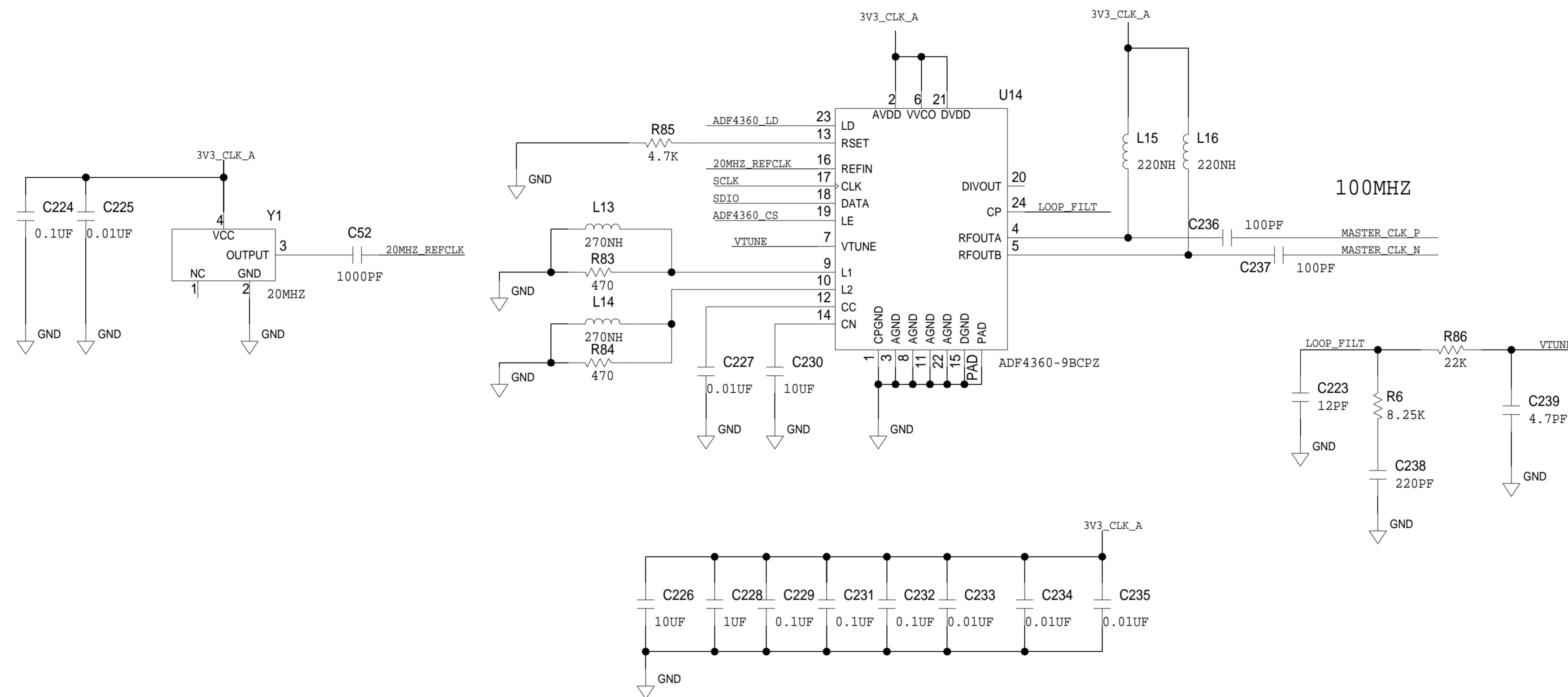

<p>THIS DRAWING IS THE PROPERTY OF ANALOG DEVICES INC. IT IS NOT TO BE REPRODUCED OR COPIED, IN WHOLE OR IN PART, OR USED IN FURNISHING INFORMATION TO OTHERS, OR FOR ANY OTHER PURPOSE DETRIMENTAL TO THE INTERESTS OF ANALOG DEVICES. THE EQUIPMENT SHOWN HEREON MAY BE PROTECTED BY PATENTS OWNED OR CONTROLLED BY ANALOG DEVICES.</p>	<b>SCHEMATIC</b>		
	HW TYPE : Customer Evaluation Z Product(s) : ad9963 : ad9963		
	DESIGN VIEW <DESIGN_VIEW>	DRAWING NO. 02_042233	REV C
	PTD ENGINEER M. BANCISOR	SIZE D	SCALE 1:1
		SHEET 9 OF 18	

REVISIONS			
REV	DESCRIPTION	DATE	APPROVED

### USB PHY

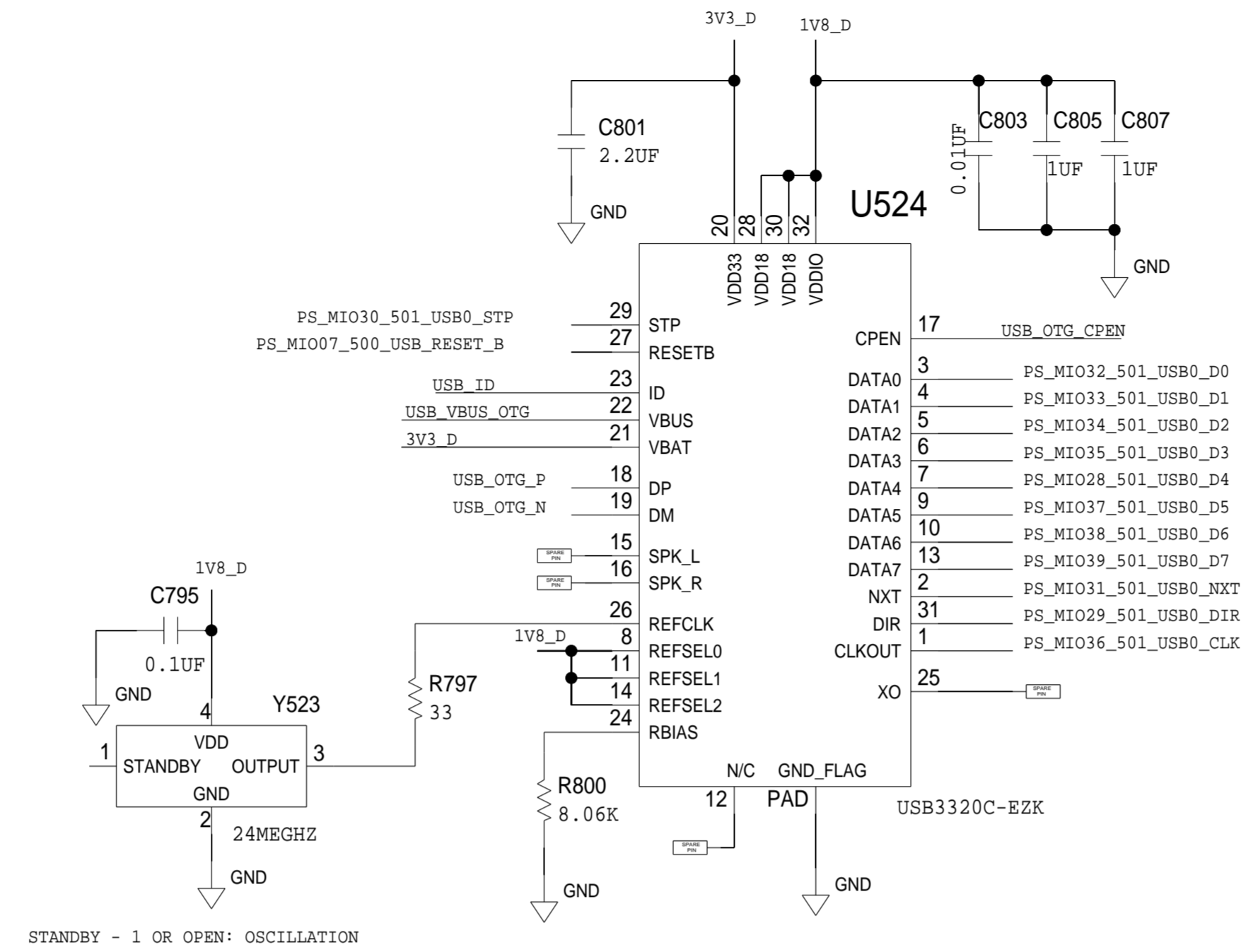

### ZYNQ BANK 501

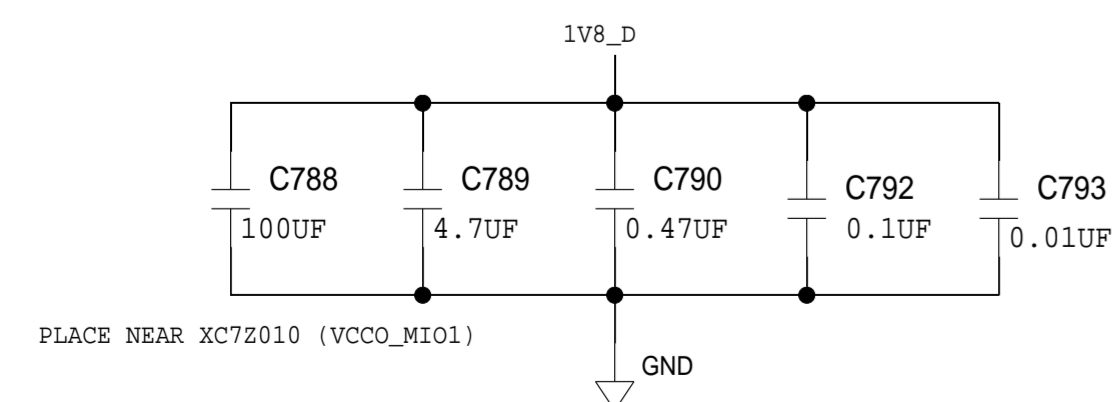
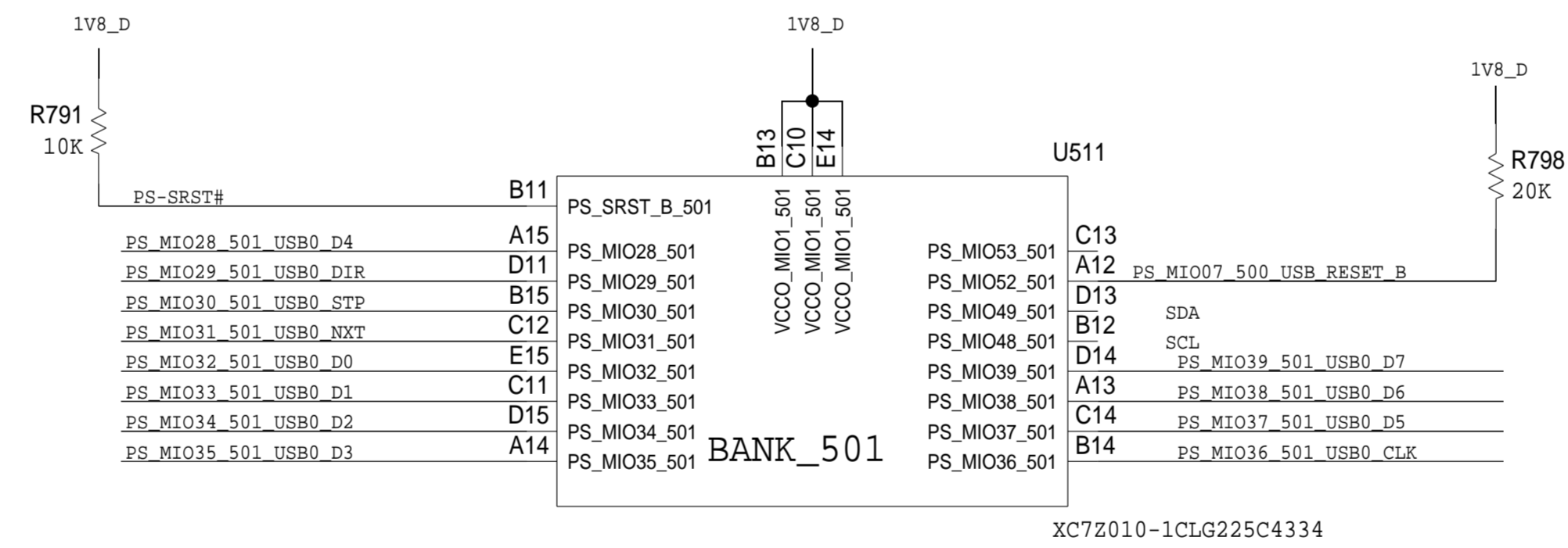

	<b>SCHEMATIC</b>		
	HW TYPE : Customer Evaluation Z Product(s) : ad9963 : ad9963		
DESIGN VIEW <DESIGN_VIEW>	DRAWING NO. 02_042233	REV C	
PTD ENGINEER M. BANCISOR	SIZE D	SCALE 1:1	SHEET 10 OF 18

REVISIONS			
REV	DESCRIPTION	DATE	APPROVED

### QSPI FLASH

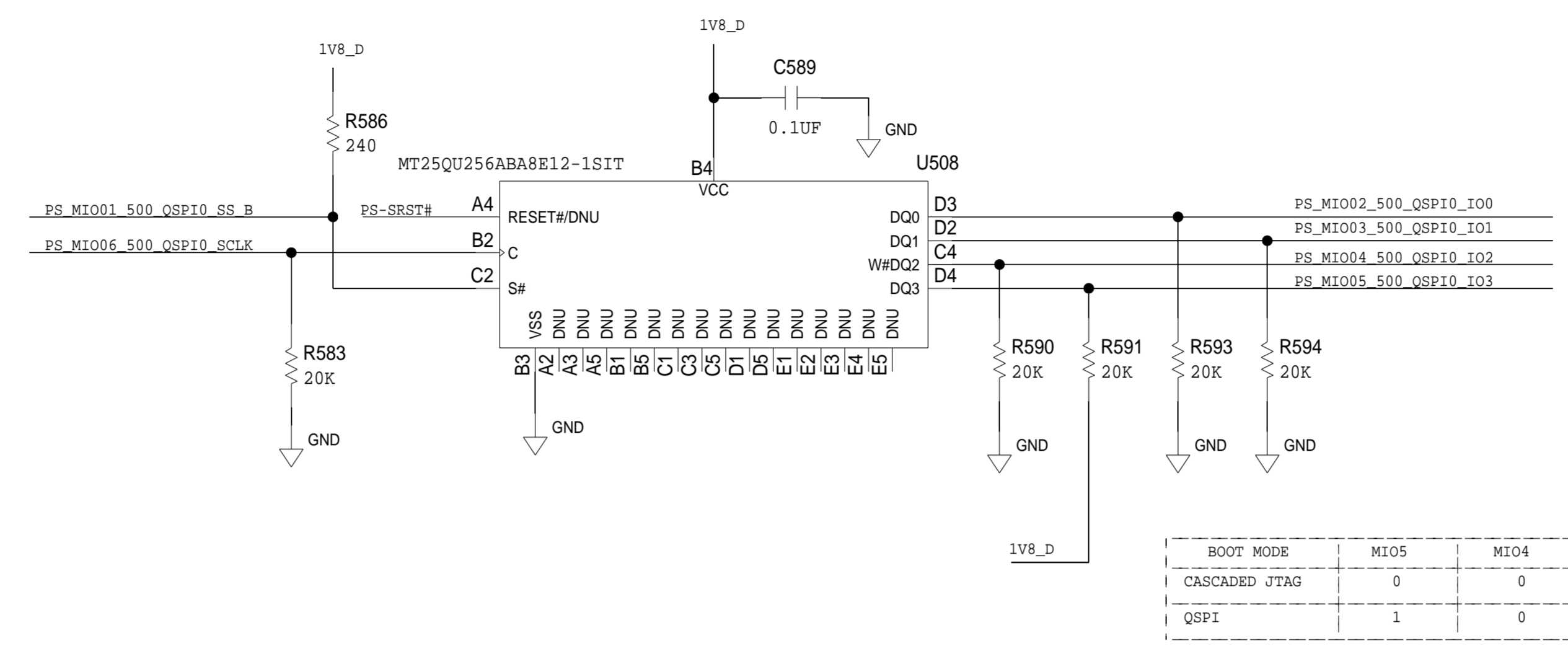

MIO5 CAN BE SHORTED TO GND BY INSERTING A JUMPER ON THE JTAG ADAPTER

WHEN USING THE ADAPTER, AND WANTING TO HAVE JTAG BOOT (DEVICE DOESN'T BOOT U-BOOT, OR KERNEL):

- INSERT THE JUMPER ON THE ADAPTER (JTAG BOOT)
- POWER UP PLUTO
- REMOVE THE JUMPER ON THE ADAPTER, SO YOU CAN TALK TO THE SPI FLASH
- DEBUG AS NORMAL.

<https://www.xilinx.com/support/answers/47596.html>

### ZYNQ BANK 500

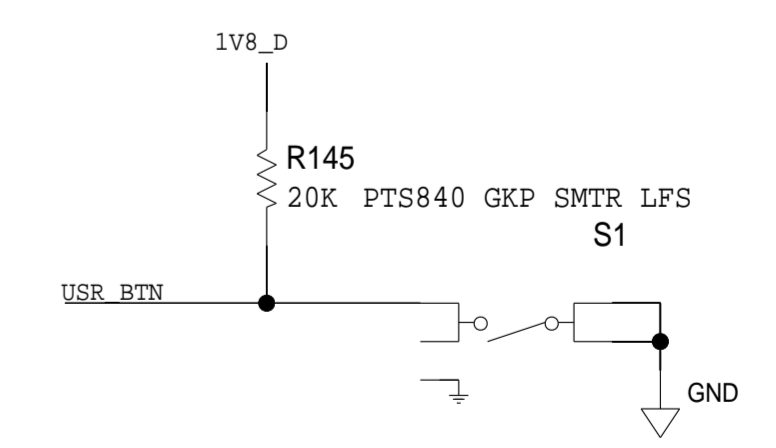
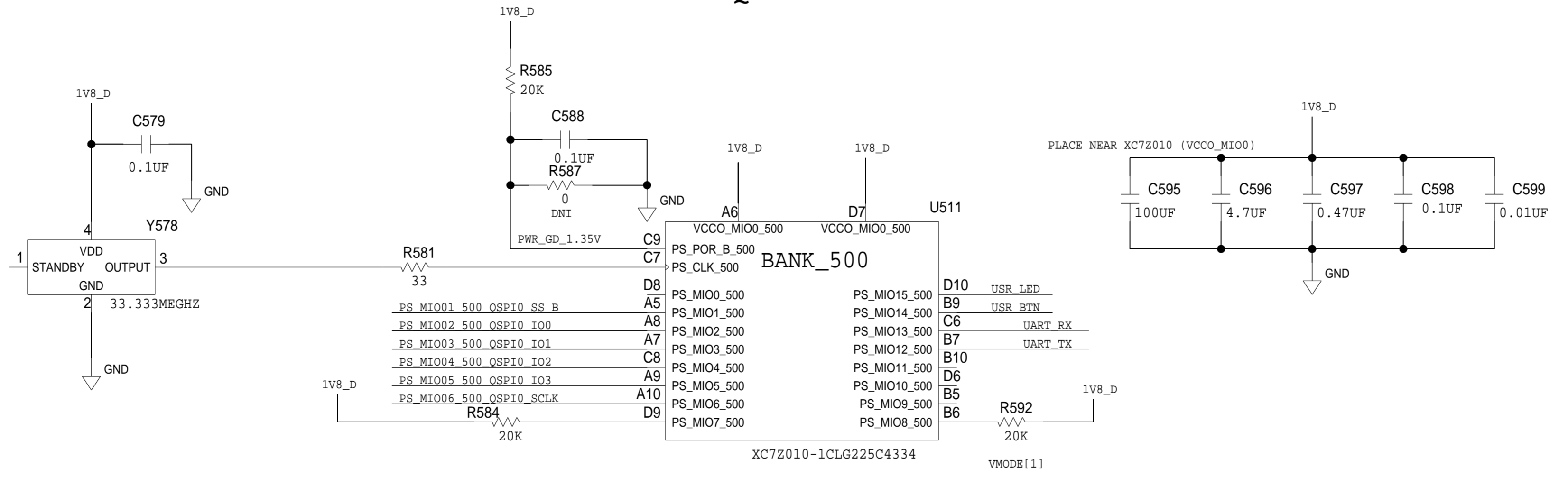

	<b>SCHEMATIC</b>		
	HW TYPE : Customer Evaluation Z Product(s) : ad9963 : ad9963		
	DESIGN VIEW <DESIGN_VIEW>	DRAWING NO. 02_042233	REV C
PTD ENGINEER M. BANCISOR	SIZE D	SCALE 1:1	SHEET 11 OF 18

# DDR 3

REVISIONS			
REV	DESCRIPTION	DATE	APPROVED

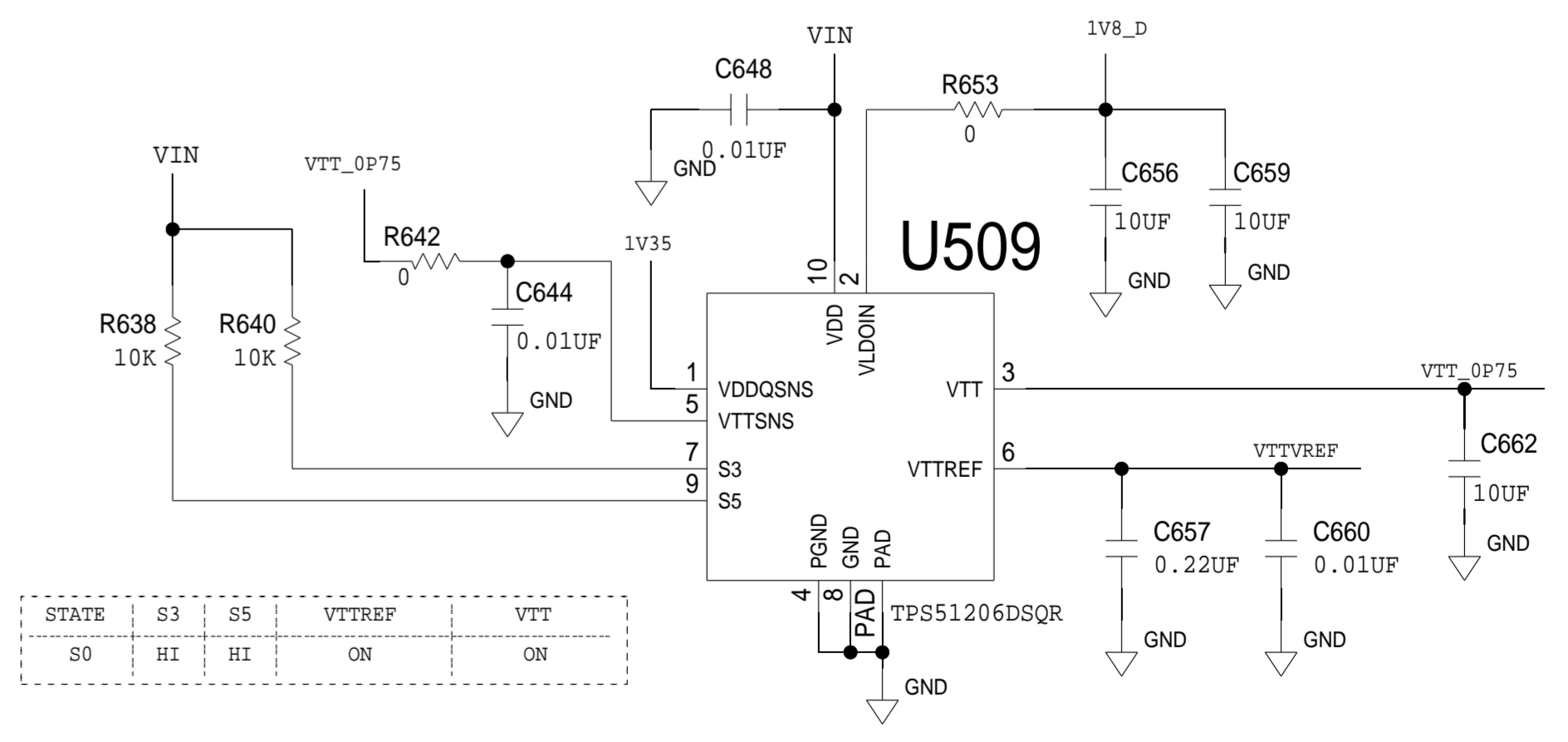
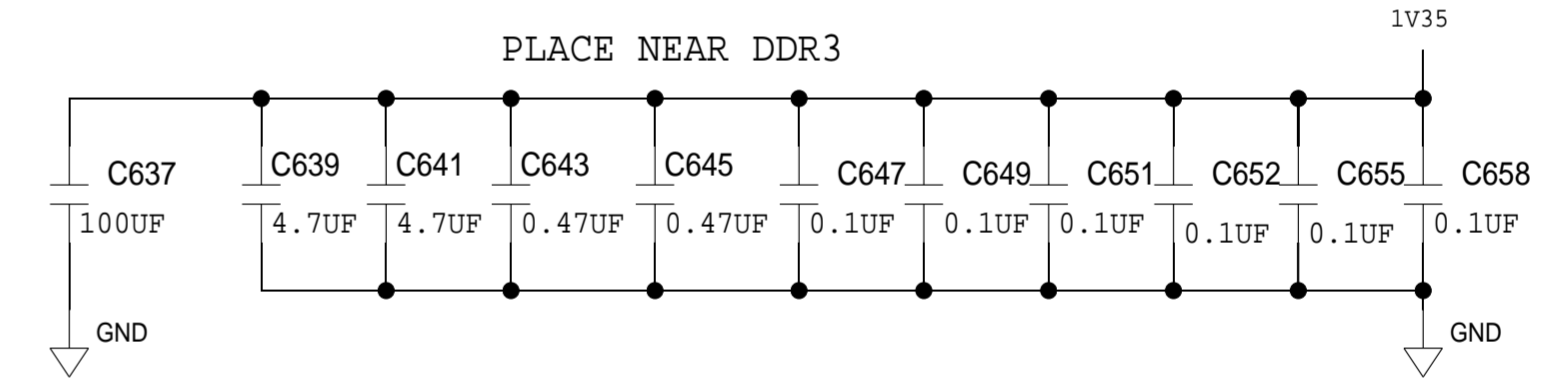
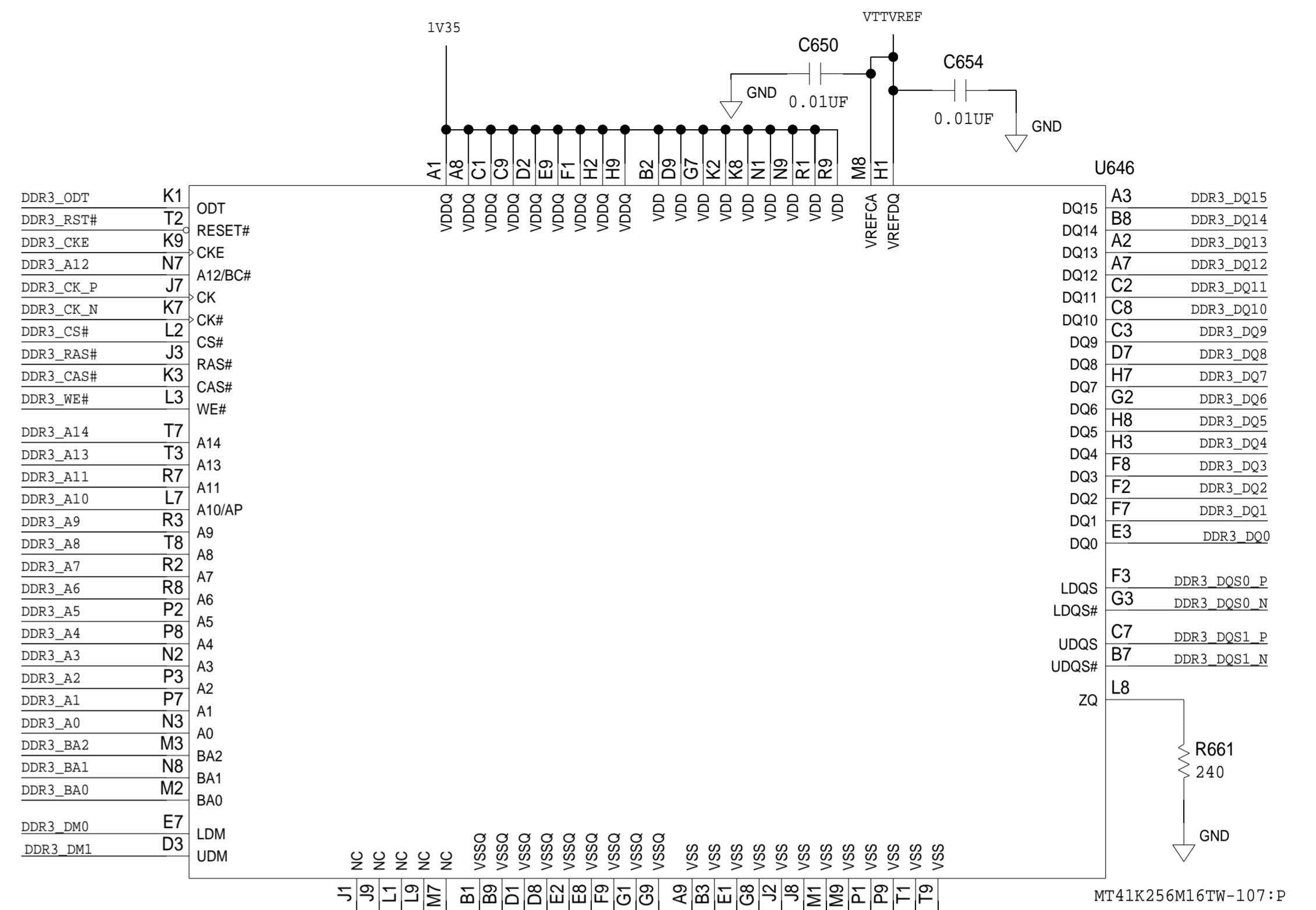
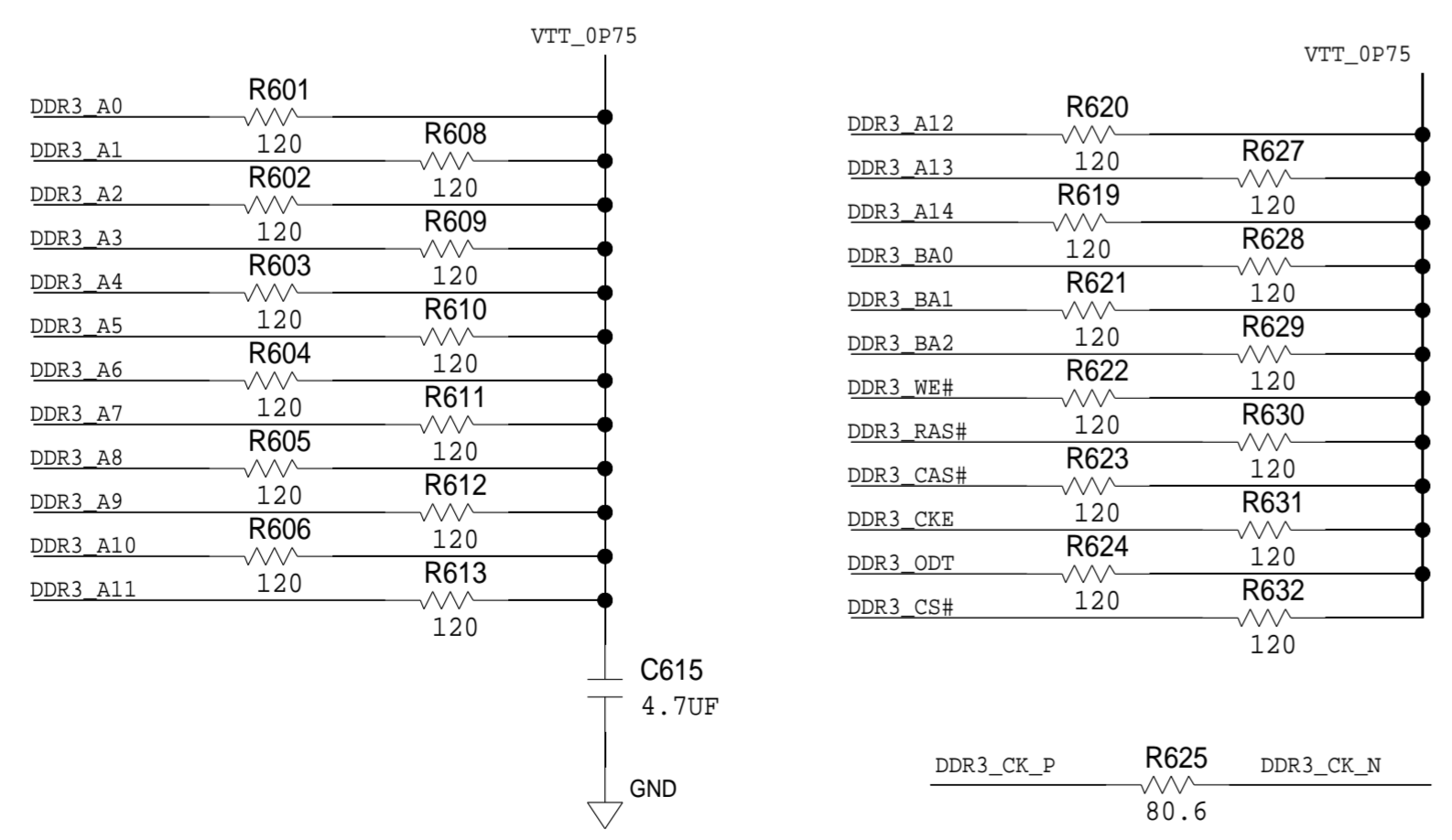
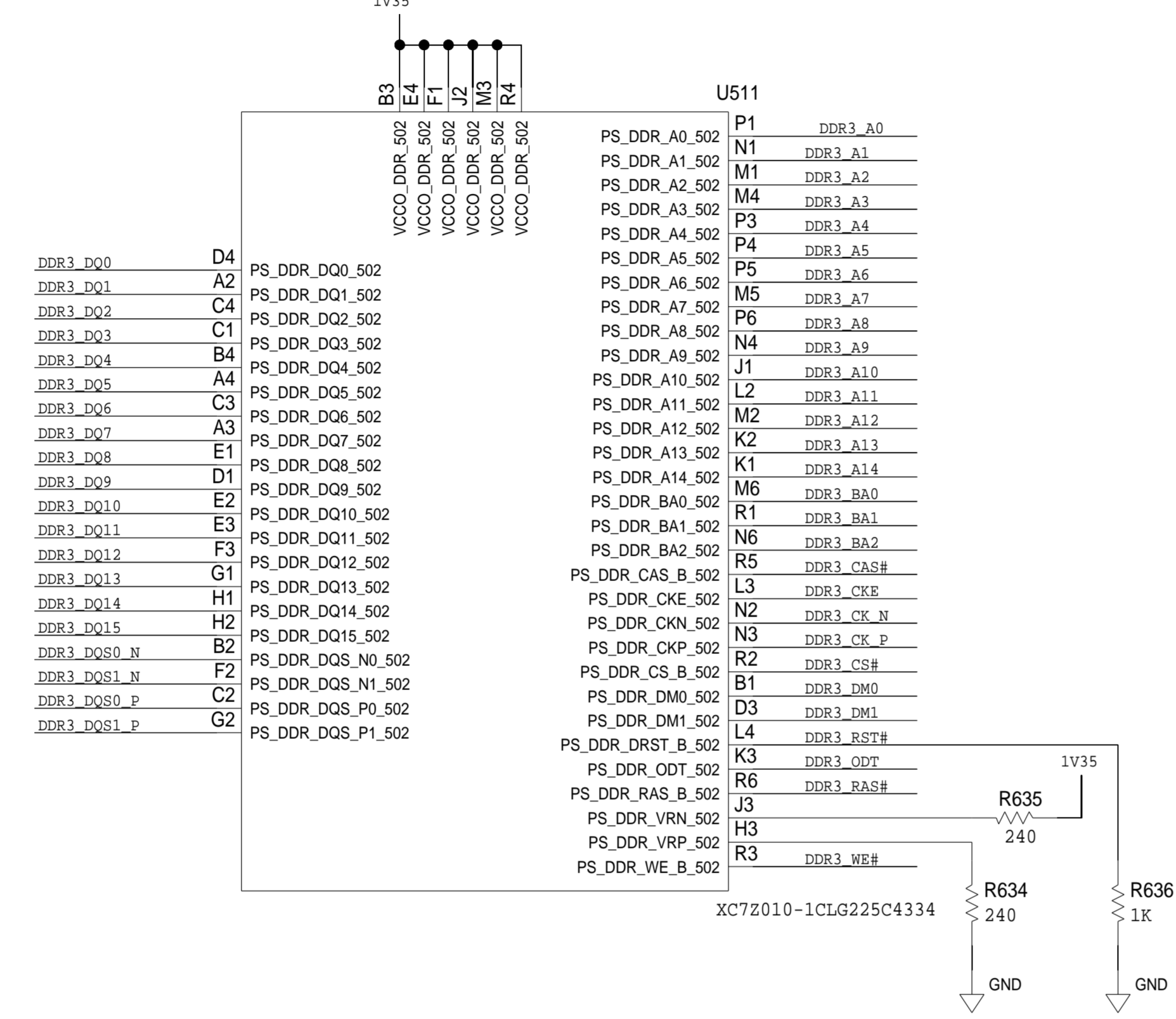
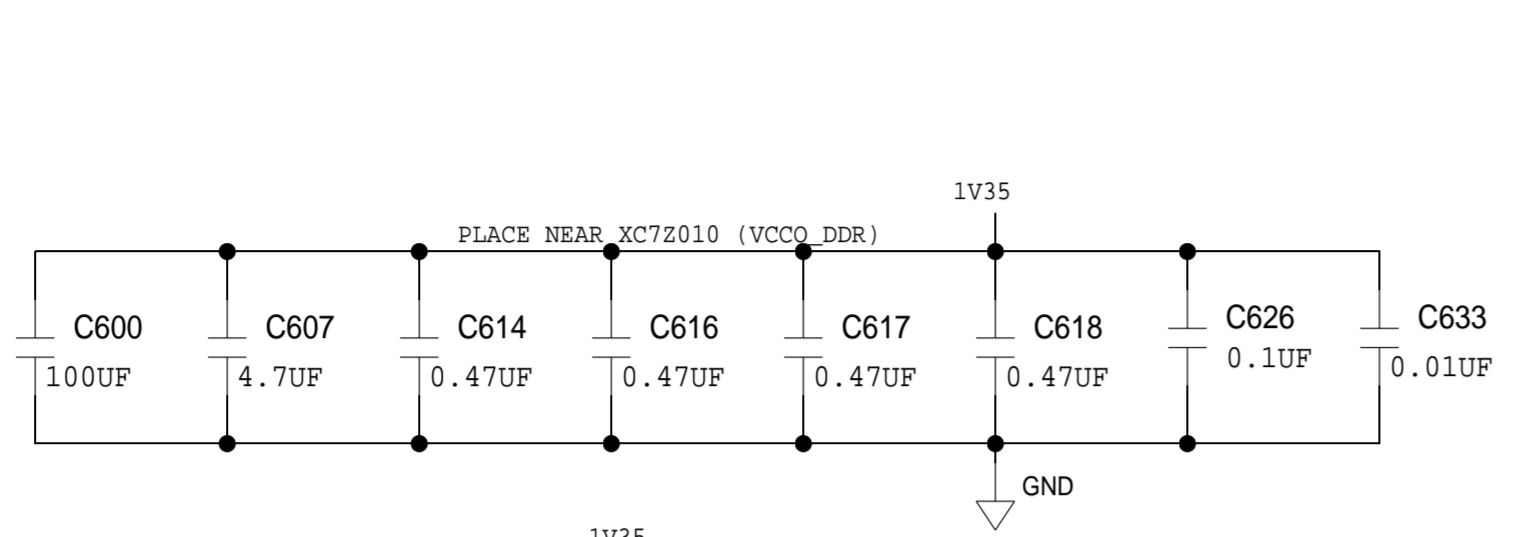

	<b>SCHEMATIC</b>		
	HW TYPE : Customer Evaluation Z Product(s) : ad9963 : ad9963		
DESIGN VIEW <DESIGN_VIEW>	DRAWING NO. 02_042233	REV C	SIZE D
PTD ENGINEER M. BANCISOR	SCALE 1:1	SHEET 12 OF 18	REV C

REVISIONS			
REV	DESCRIPTION	DATE	APPROVED

0.05 PITCH JTAG AND UART CONNECTOR

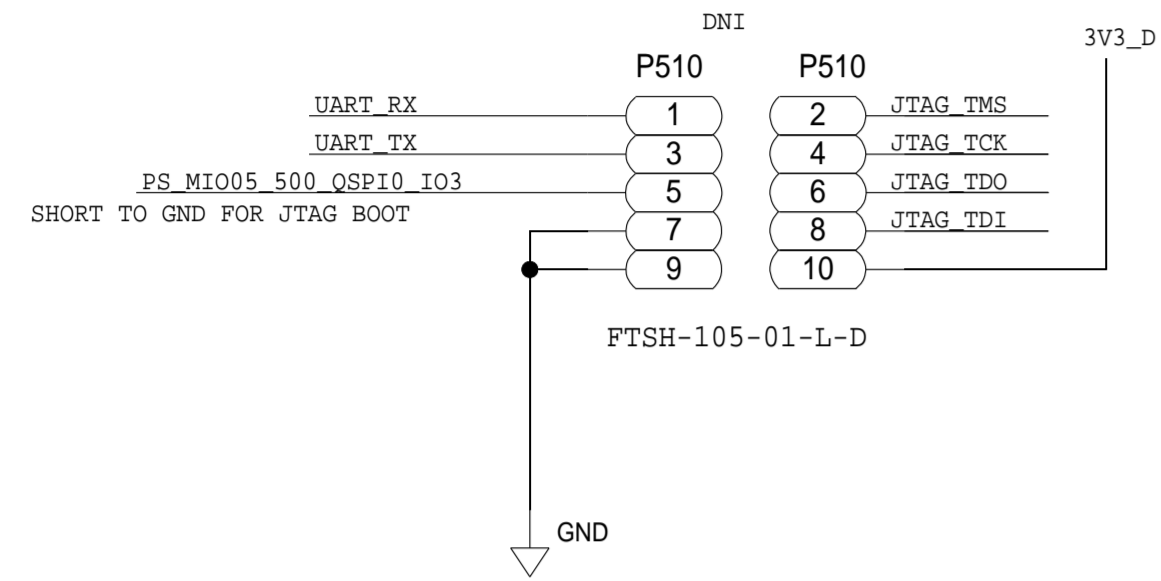

ZYNQ BANK 0

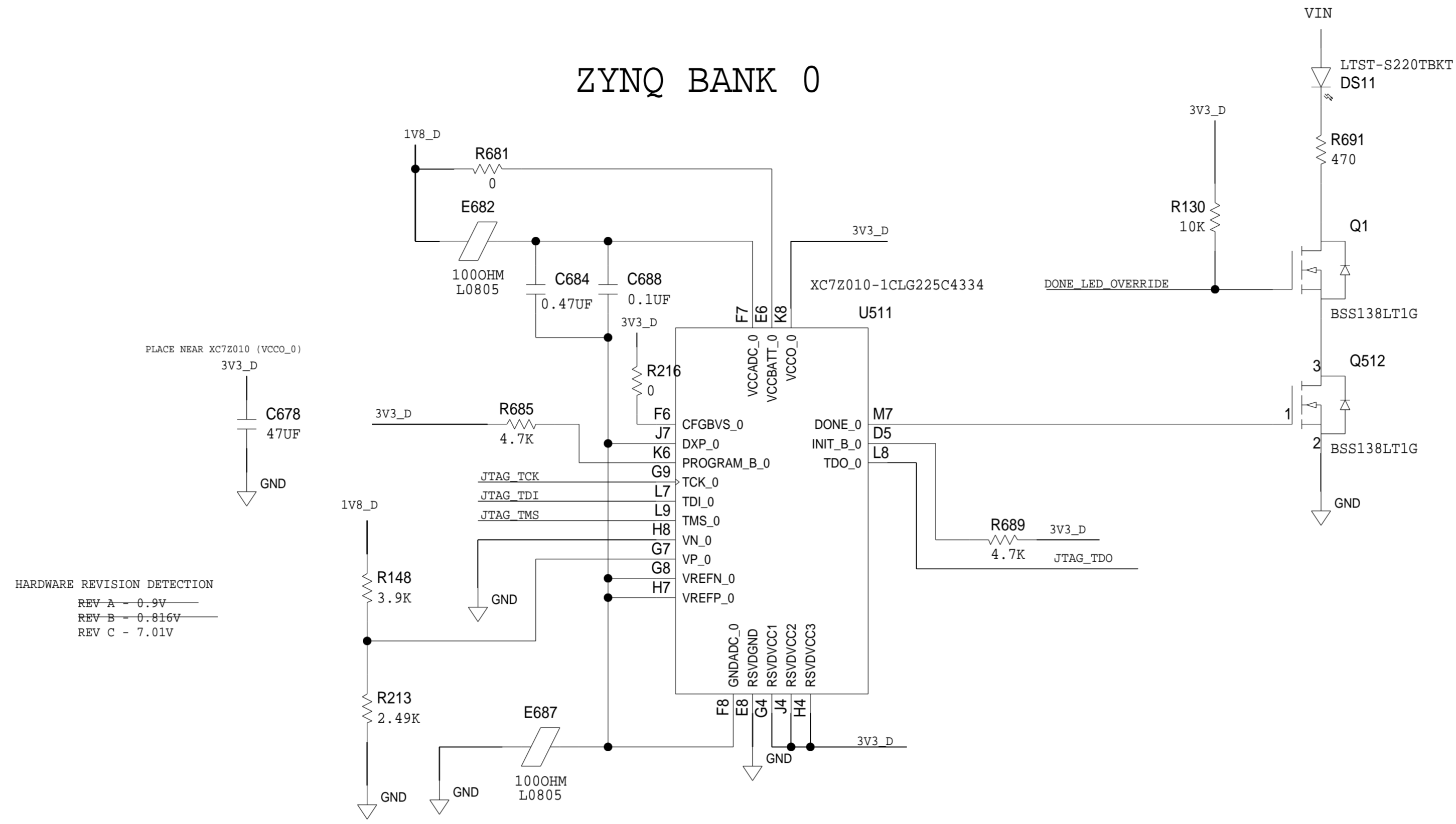

HARDWARE REVISION DETECTION  
 REV A - 0.9V  
 REV B - 0.816V  
 REV C - 7.01V

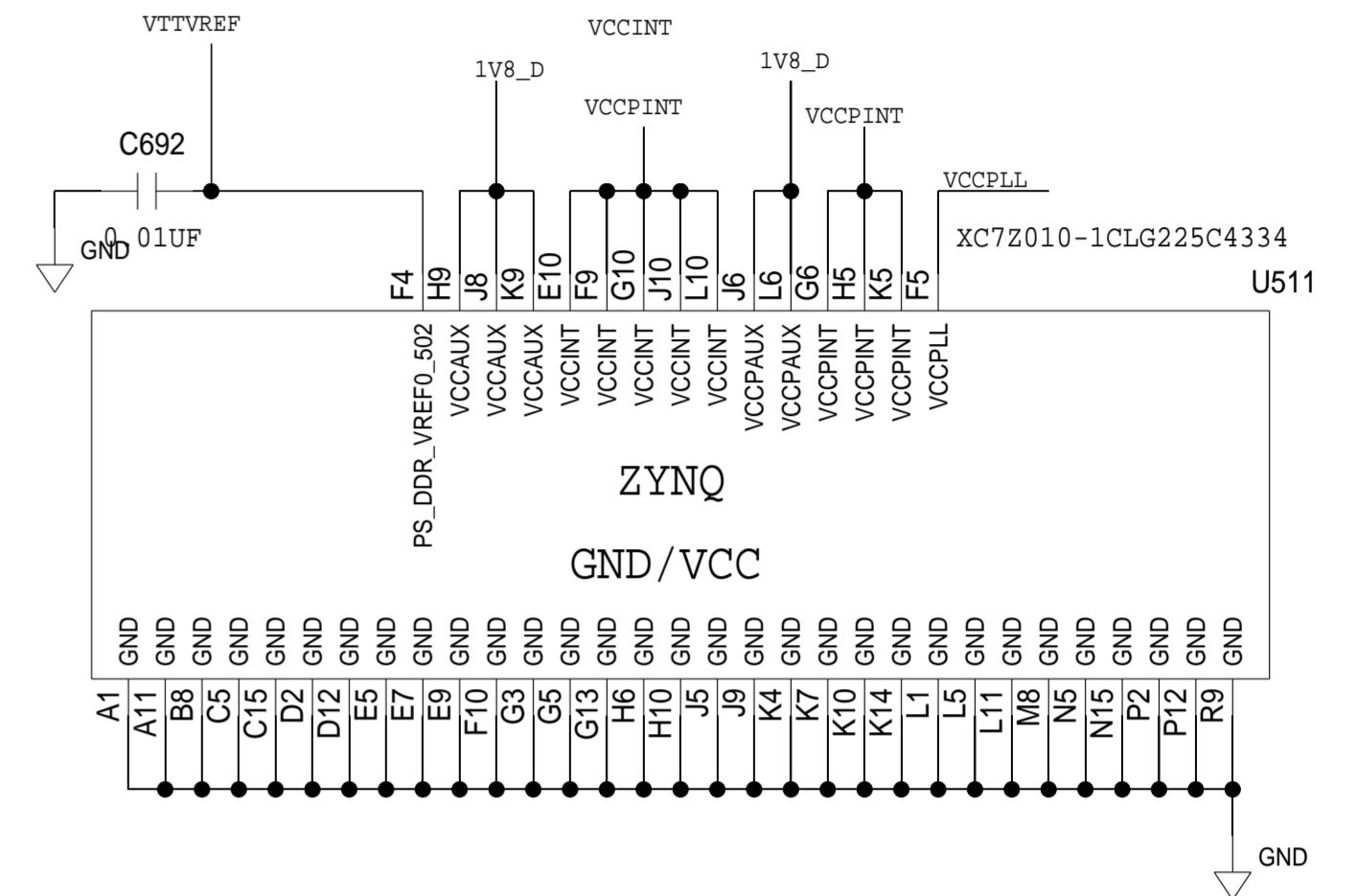

USER LED

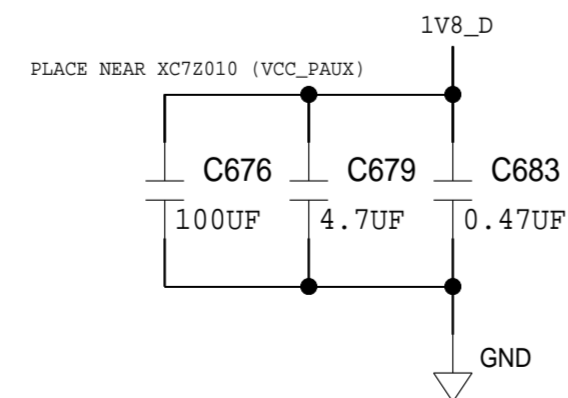
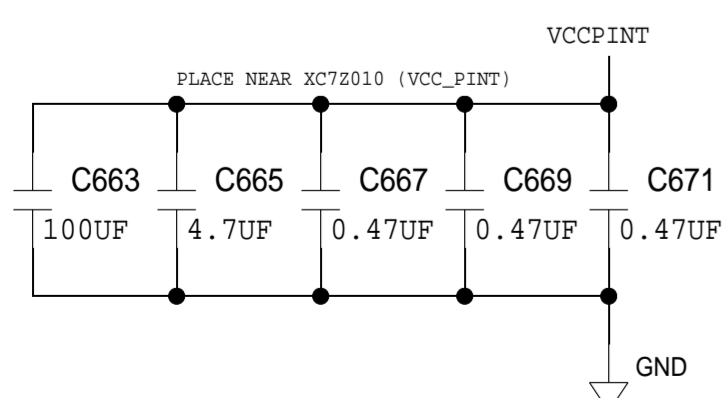
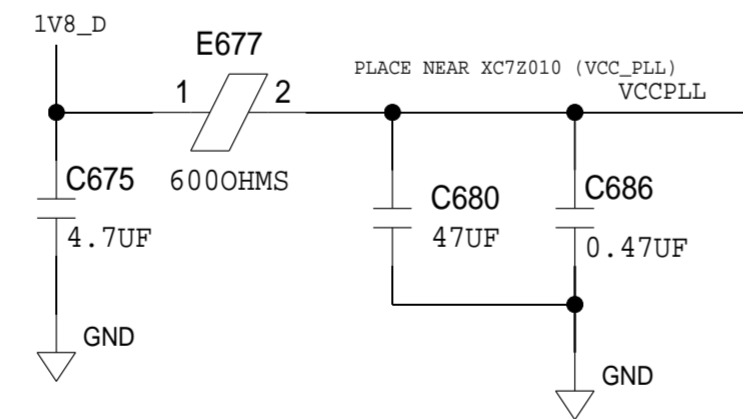
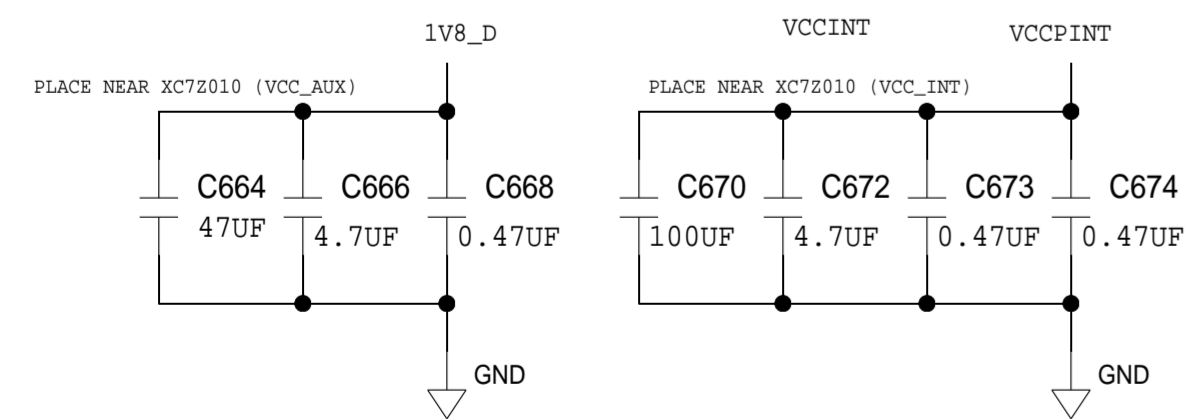
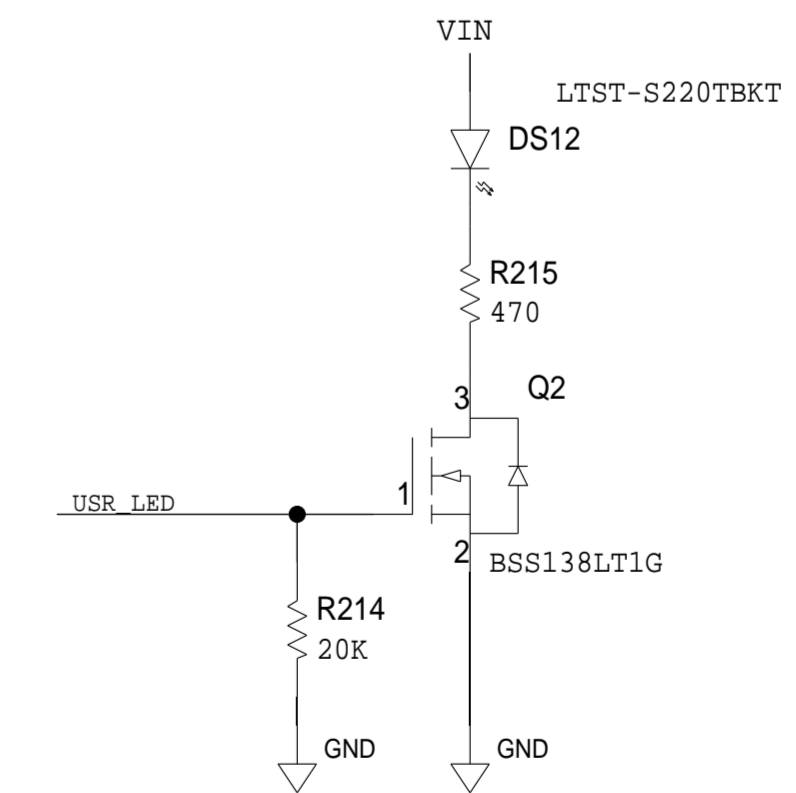

ANALOG DEVICES				SCHEMATIC			
<small>THIS DRAWING IS THE PROPERTY OF ANALOG DEVICES INC. IT IS NOT TO BE REPRODUCED OR COPIED, IN WHOLE OR IN PART, OR USED IN ANY MANNER THAT MIGHT BE DETRIMENTAL TO THE INTERESTS OF ANALOG DEVICES. THE EQUIPMENT SHOWN HEREIN MAY BE PROTECTED BY PATENTS OWNED OR CONTROLLED BY ANALOG DEVICES.</small>				HW TYPE : Customer Evaluation Z			
				Product(s) : ad9963 : ad9963			
DESIGN VIEW <DESIGN_VIEW>		DRAWING NO. 02_042233		REV C			
PTD ENGINEER M. BANCISOR		SIZE D	SCALE 1:1	SHEET 13 OF 18			

# ZYNQ BANK 34,35

REVISIONS			
REV	DESCRIPTION	DATE	APPROVED

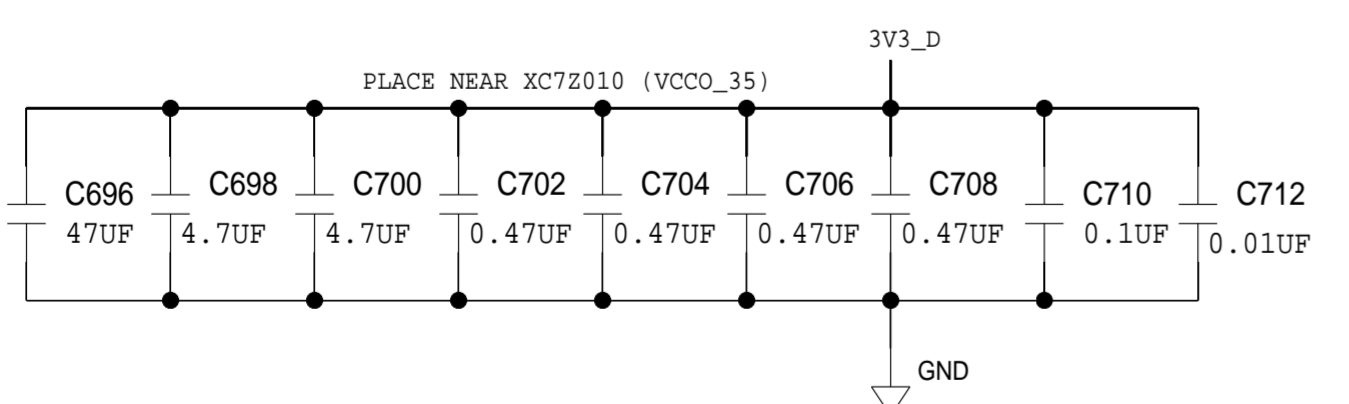
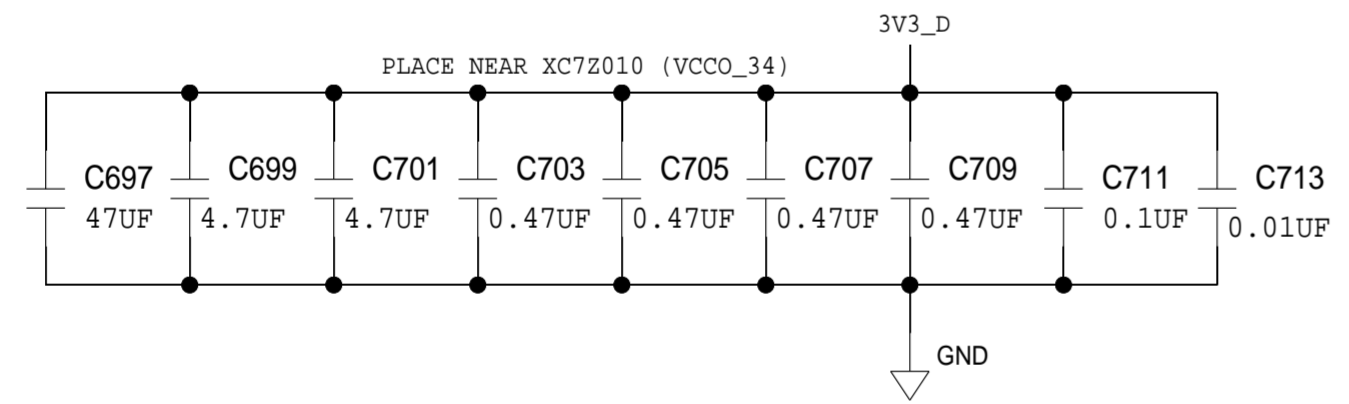
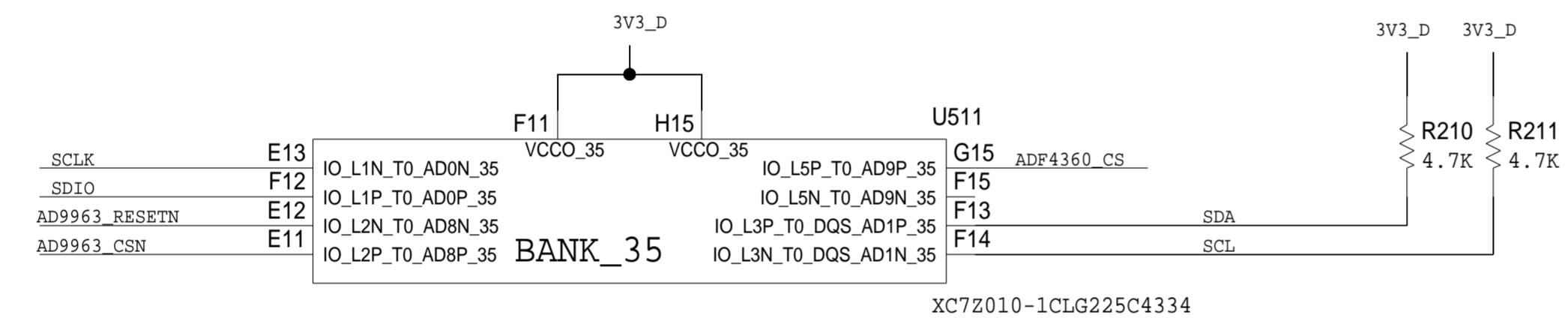
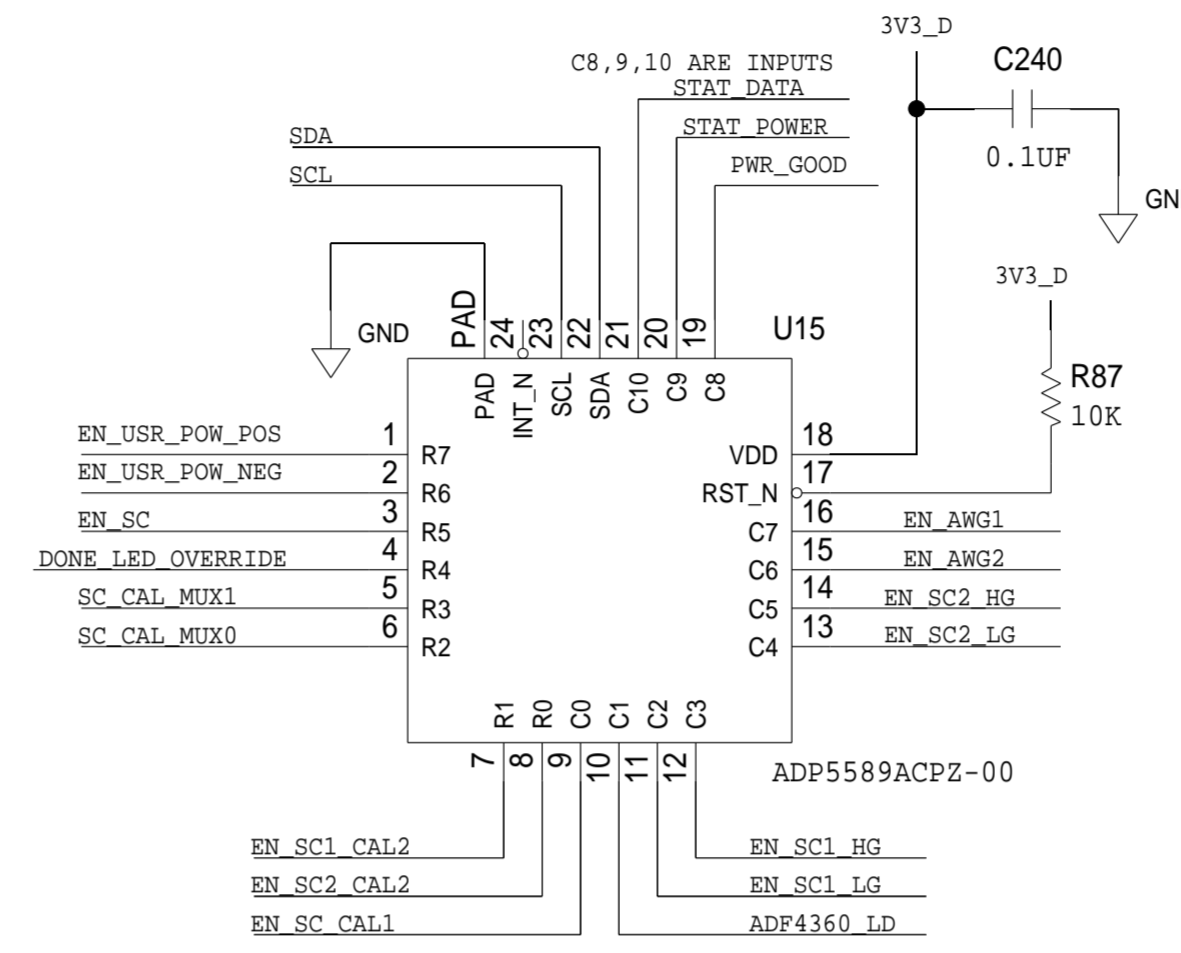
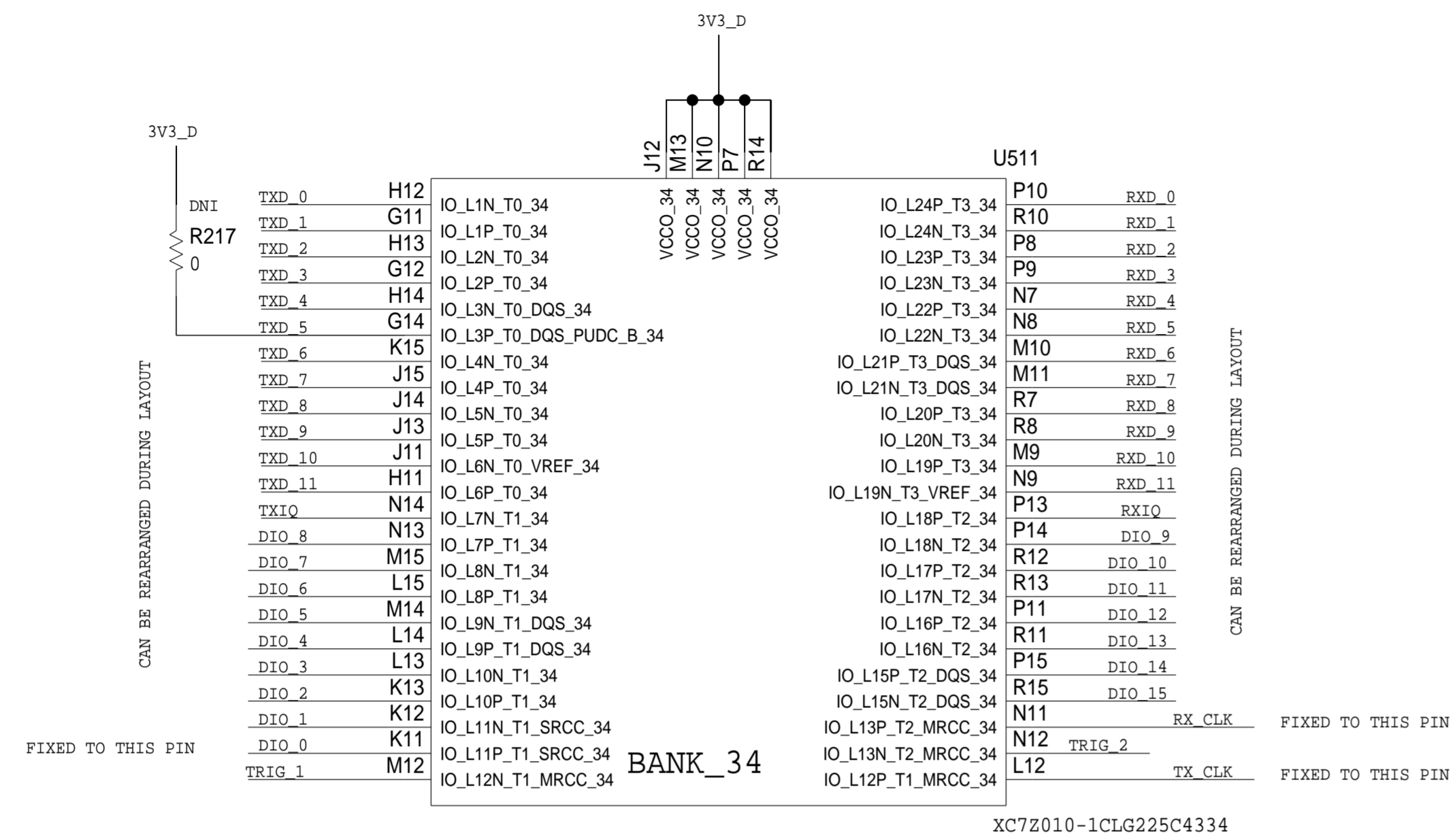

I2C DEVICE	ADDRESS
ADM1177-1	???
M24C02	???
56 PINS	

	<b>SCHEMATIC</b>		
	HW TYPE : Customer Evaluation Z Product(s) : ad9963 : ad9963		
DESIGN VIEW <DESIGN_VIEW>	DRAWING NO. 02_042233	REV C	
PTD ENGINEER M. BANCISOR	SIZE D	SCALE 1:1	SHEET 14 OF 18

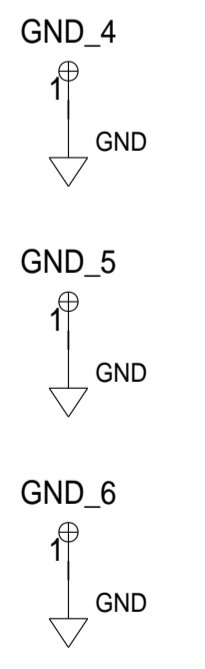

# POSITIVE POWER SUPPLIES- ANALOG STAGE

REVISIONS			
REV	DESCRIPTION	DATE	APPROVED

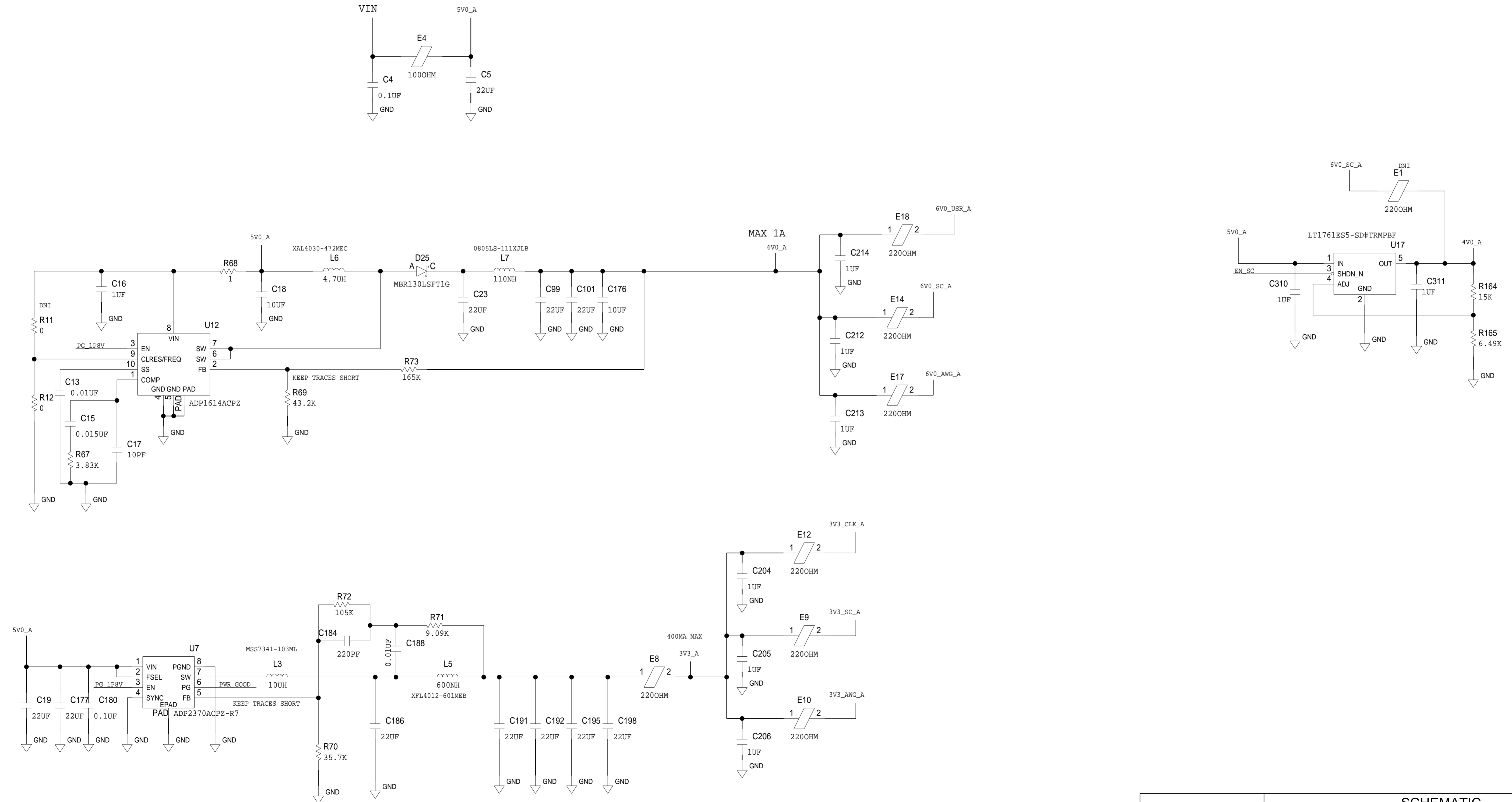

SCHEMATIC			
		HW TYPE : Customer Evaluation Z Product(s) : ad9963 : ad9963	
DESIGN VIEW <DESIGN_VIEW>	DRAWING NO. 02_042233	REV C	
PTD ENGINEER M. BANCISOR	SIZE D	SCALE 1:1	SHEET 15 OF 18

# NEGATIVE POWER SUPPLIES- ANALOG STAGE

REVISIONS			
REV	DESCRIPTION	DATE	APPROVED

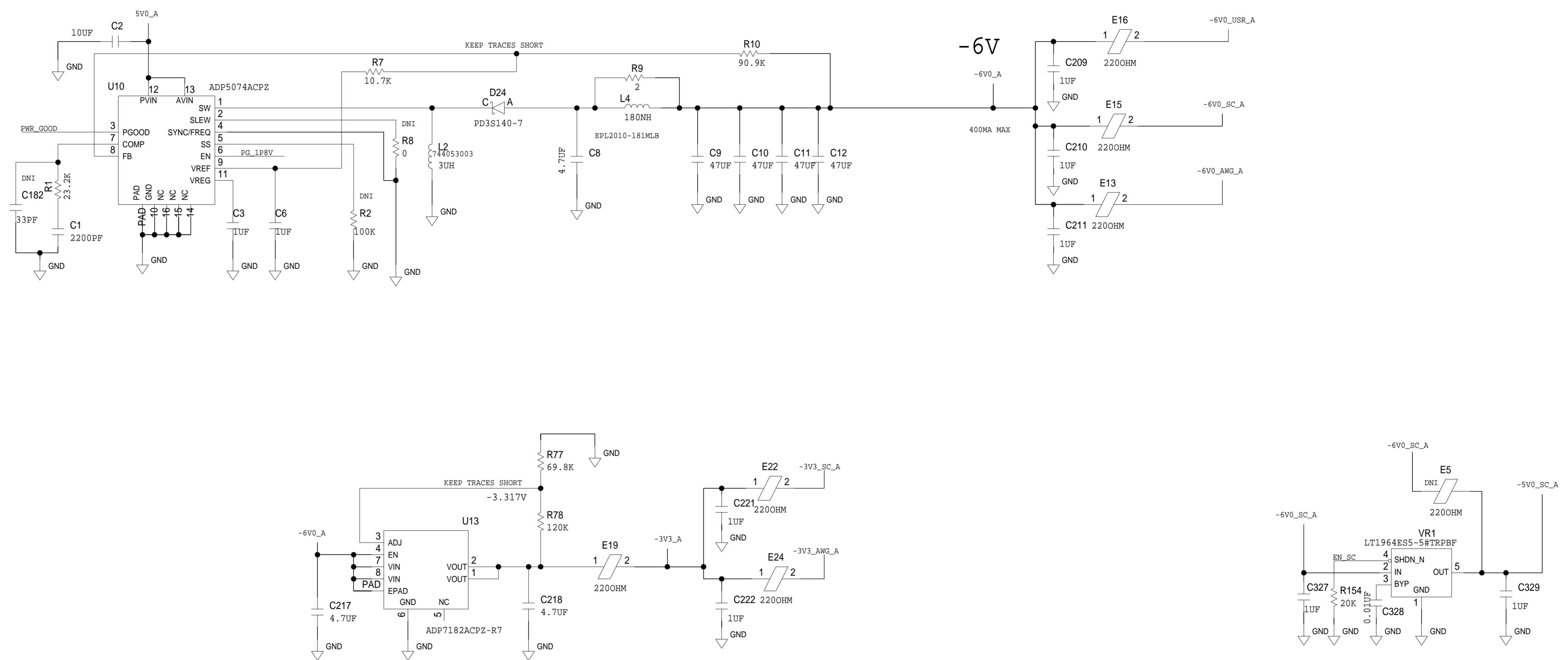

<p>THIS DRAWING IS THE PROPERTY OF ANALOG DEVICES INC. IT IS NOT TO BE REPRODUCED OR COPIED, IN WHOLE OR IN PART, OR USED IN FURNISHING INFORMATION TO OTHERS, OR FOR ANY OTHER PURPOSE DETRIMENTAL TO THE INTERESTS OF ANALOG DEVICES. THE EQUIPMENT SHOWN HEREIN MAY BE PROTECTED BY PATENTS OWNED OR CONTROLLED BY ANALOG DEVICES.</p>	<b>SCHEMATIC</b>		
	HW TYPE : Customer Evaluation Z Product(s) : ad9963 : ad9963		
	DESIGN VIEW <DESIGN_VIEW>	DRAWING NO. 02_042233	REV C
	PTD ENGINEER M. BANCISOR	SIZE D	SCALE 1:1
		SHEET 16 OF 18	



REVISIONS			
REV	DESCRIPTION	DATE	APPROVED

POWER MANAGEMENT SECTION

USB CONNECTORS

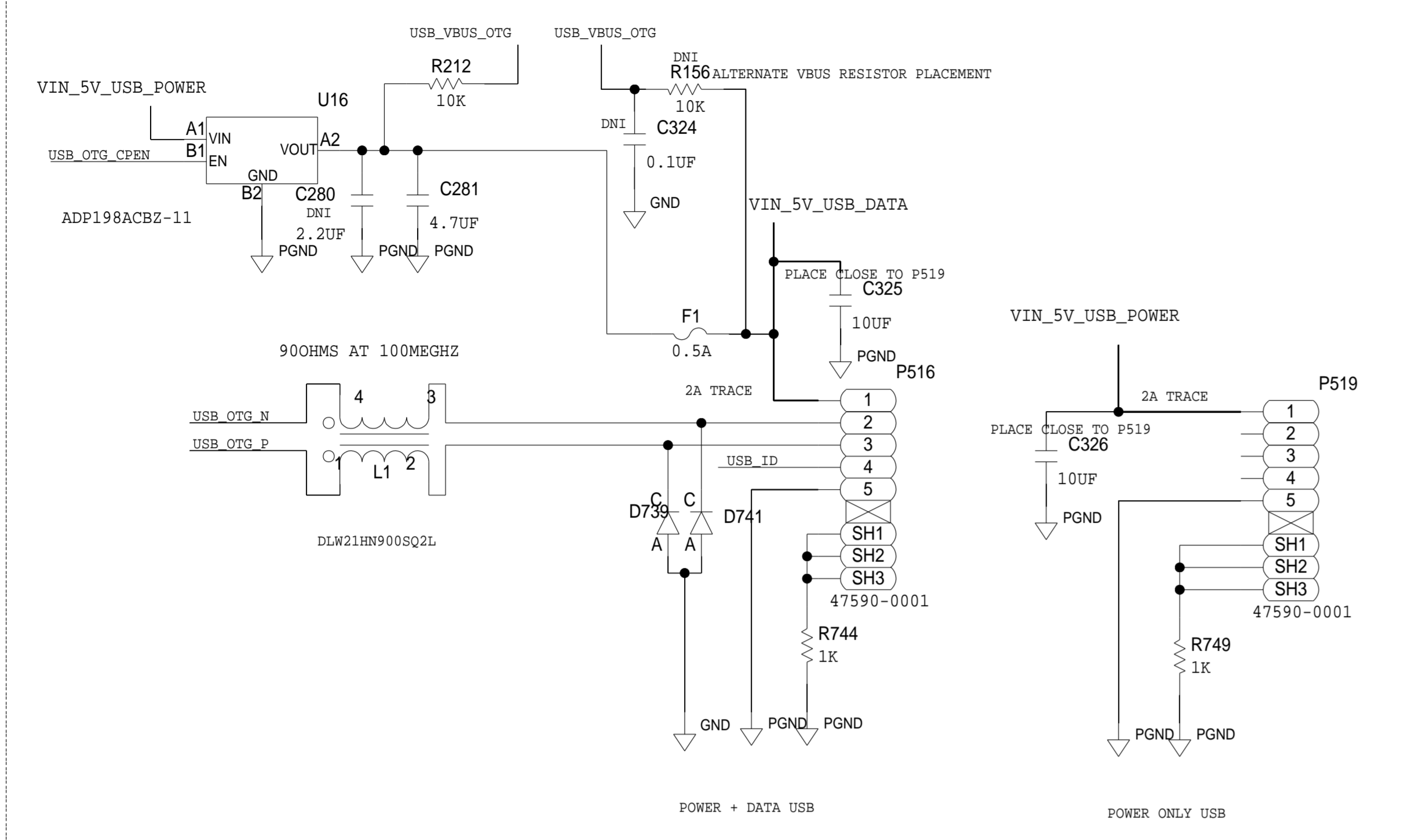

POWER SELECTOR  
INRUSH AND OVERCURRENT PROTECTION

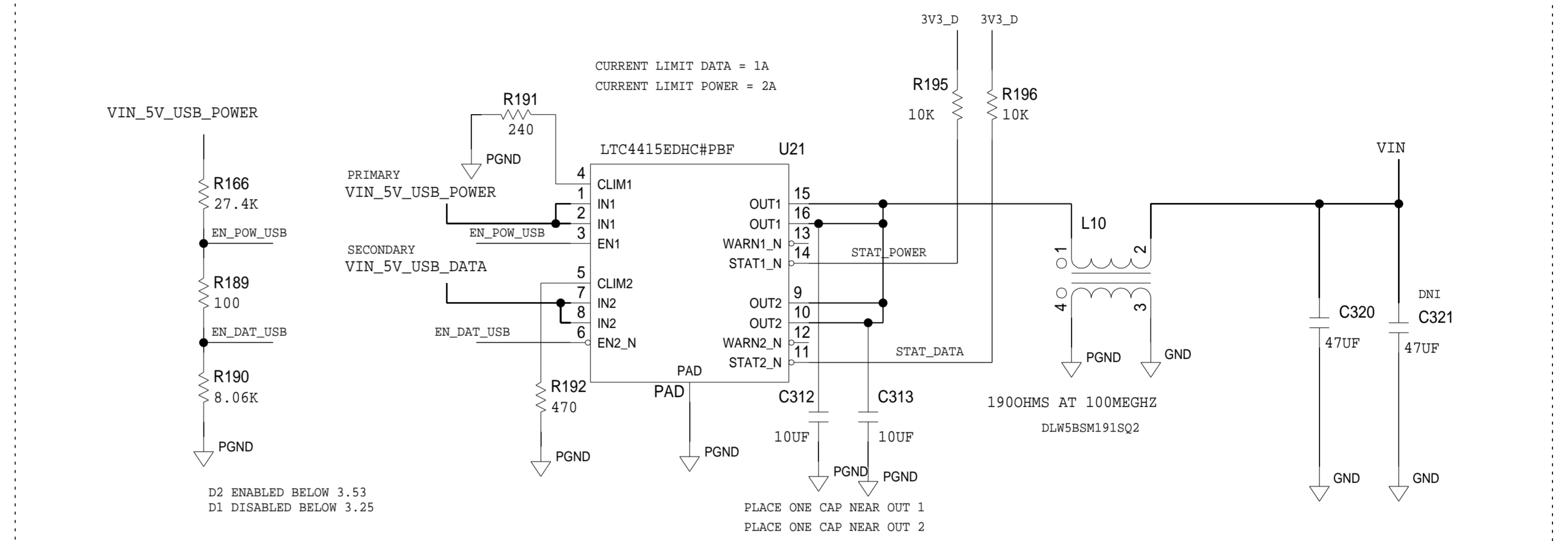

TESTPOINTS FOR FACTORY CALIBRATION

JTAG & UART

- TMS JTAG\_TMS
- TCK JTAG\_TCK
- TDO JTAG\_TDO
- TDI JTAG\_TDI
- RX UART\_RX
- TX UART\_TX
- IO3 PS\_MI005\_500\_OSPI0\_IO3

- VIN VIN
- 1V8\_D 1V8\_D
- 1V35 1V35
- VCCPINT VCCPINT
- 3V3\_D 3V3\_D
- 6V0\_A 6V0\_A
- 6V0\_A -6V0\_A
- 3V3\_A 3V3\_A
- 3V3\_A -3V3\_A
- 4V0\_A 4V0\_A

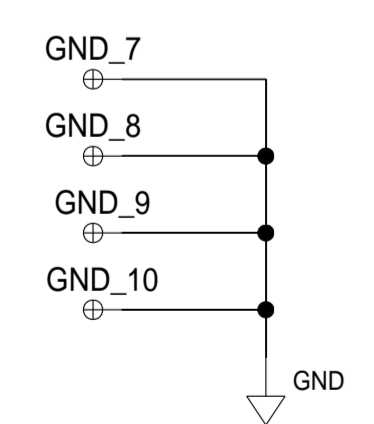

REFERENCES

- CALIB\_REF1 CALIB\_REFERENCE1
- CALIB\_REF2 CALIB\_REFERENCE2

DIGITAL POWER SEQUENCE:

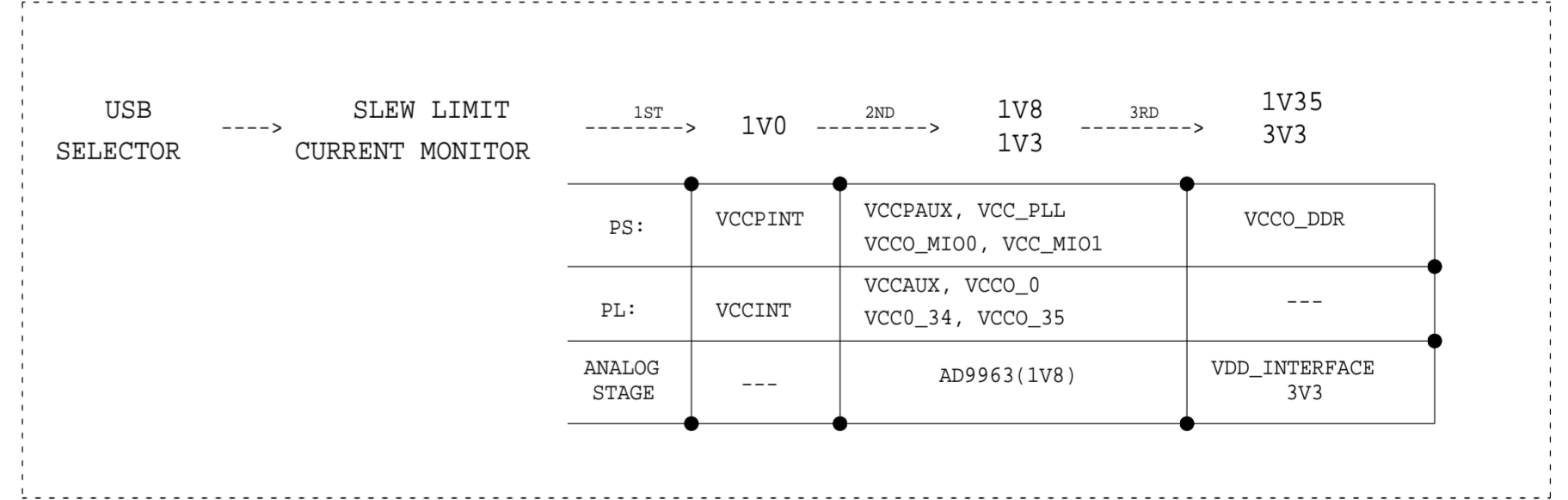

	<b>SCHEMATIC</b>		
	HW TYPE : Customer Evaluation Z Product(s): ad9963 : ad9963		
DESIGN VIEW <DESIGN_VIEW>	DRAWING NO. 02_042233	REV C	
PTD ENGINEER M. BANCISOR	SIZE D	SCALE 1:1	SHEET 17 OF 18

# DIGITAL POWER SUPPLIES

REVISIONS			
REV	DESCRIPTION	DATE	APPROVED

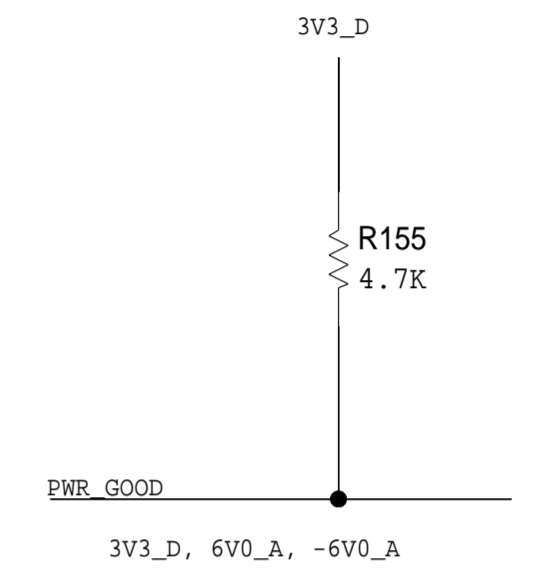
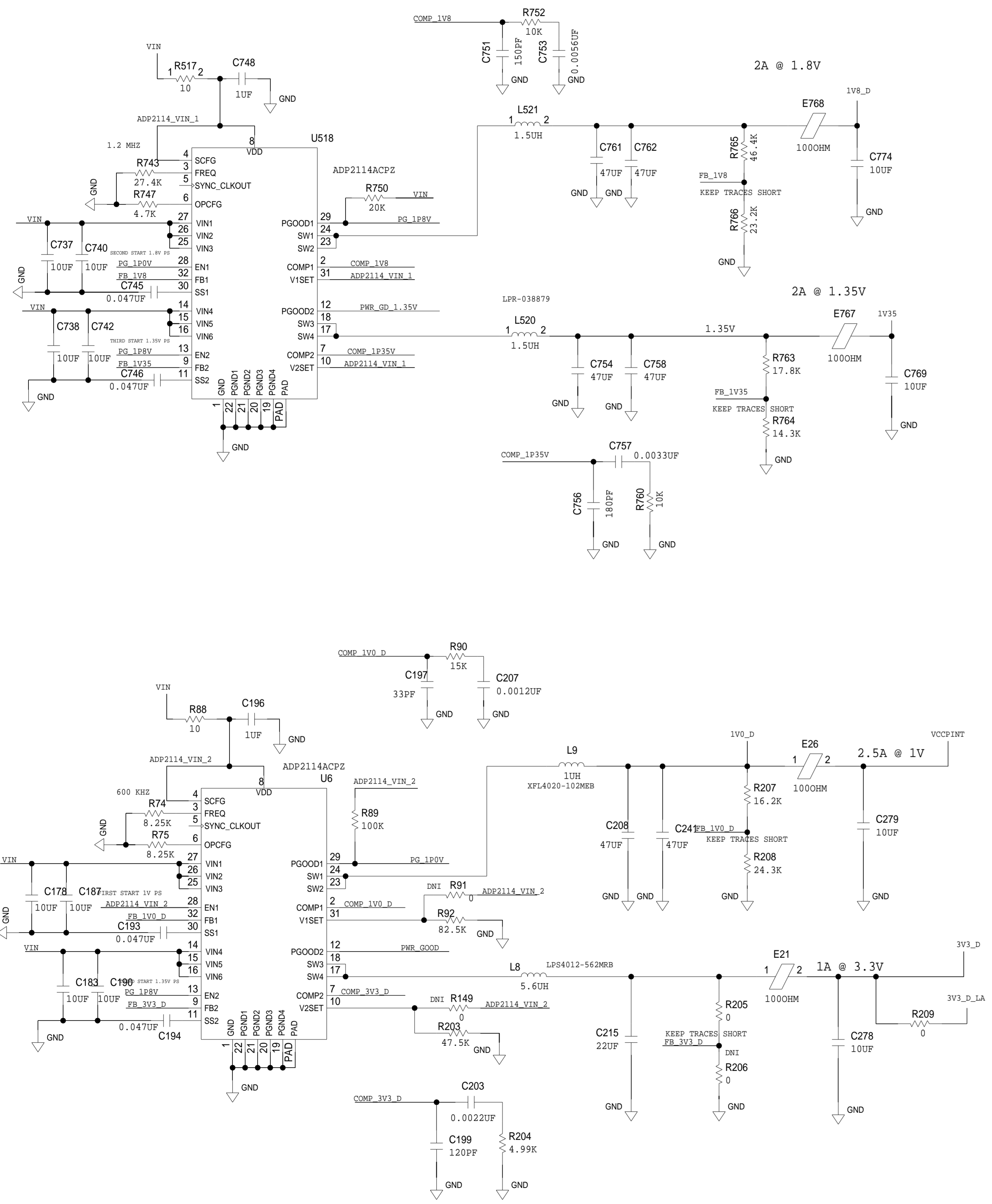

	<b>SCHEMATIC</b>		
	HW TYPE : Customer Evaluation Z Product(s) : ad9963 : ad9963		
THIS DRAWING IS THE PROPERTY OF ANALOG DEVICES INC. IT IS NOT TO BE REPRODUCED OR COPIED, IN WHOLE OR IN PART, OR USED IN ANY MANNER WITHOUT THE WRITTEN PERMISSION OF ANALOG DEVICES. THE EQUIPMENT SHOWN HEREIN MAY BE PROTECTED BY PATENTS OWNED OR CONTROLLED BY ANALOG DEVICES.	DESIGN VIEW <DESIGN_VIEW>	DRAWING NO. 02_042233	REV C
PTD ENGINEER M. BANCISOR	SIZE D	SCALE 1:1	SHEET 18 OF 18