

Single N-Channel Enhancement Mode MOSFET

Features

- 60V/11A
 $R_{DS(ON)} = 12\text{ m}\Omega$ (typ.) @ $V_{GS} = 10\text{V}$
 $R_{DS(ON)} = 13.5\text{ m}\Omega$ (typ.) @ $V_{GS} = 4.5\text{V}$
- Avalanche Rated
- Reliable and Rugged
- Lead Free and Green Devices Available (RoHS Compliant)

Pin Description

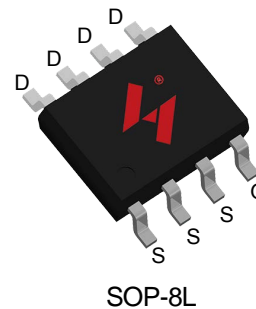

Applications

- Power Management for Inverter Systems
- Switching application
- DC/DC Converter

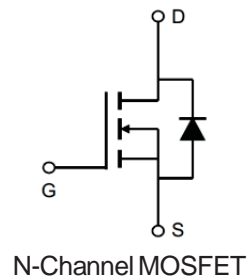

Ordering and Marking Information

 S HY1106 YYXXXJWW G	Package Code S : SOP-8 Date Code YYXXX WW Assembly Material G : Lead Free Device
--	---

Note: HUAYI lead-free products contain molding compounds/die attach materials and 100% matte tin plate Termination finish; which are fully compliant with RoHS. HUAYI lead-free products meet or exceed the lead-free requirements of IPC/JEDEC J-STD-020 for MSL classification at lead-free peak reflow temperature. HUAYI defines “Green” to mean lead-free (RoHS compliant) and halogen free (Br or Cl does not exceed 900ppm by weight in homogeneous material and total of Br and Cl does not exceed 1500ppm by weight).

HUAYI reserves the right to make changes, corrections, enhancements, modifications, and improvements to this product and/or to this document at any time without notice.

Absolute Maximum Ratings

Symbol	Parameter	Rating	Unit	
Common Ratings ($T_C=25^{\circ}\text{C}$ Unless Otherwise Noted)				
V_{DSS}	Drain-Source Voltage	60	V	
V_{GSS}	Gate-Source Voltage	± 20		
T_J	Maximum Junction Range	-55 to 175	$^{\circ}\text{C}$	
T_{STG}	Storage Temperature Range	-55 to 175	$^{\circ}\text{C}$	
I_S	Diode Continuous Forward Current	$T_C=25^{\circ}\text{C}$	11	A
Mounted on Large Heat Sink				
I_{DM}	Pulsed Drain Current *	$T_C=25^{\circ}\text{C}$	44**	A
I_D	Continuous Drain Current	$T_C=25^{\circ}\text{C}$	11	A
		$T_C=70^{\circ}\text{C}$	8.2	
P_D	Maximum Power Dissipation	$T_C=25^{\circ}\text{C}$	3.5	W
		$T_C=70^{\circ}\text{C}$	2.4	
$R_{\theta JC}$	Thermal Resistance-Junction to Case		43	$^{\circ}\text{C/W}$
$R_{\theta JA}$	Thermal Resistance-Junction to Ambient		75	
Avalanche Ratings				
E_{AS}	Avalanche Energy, Single Pulsed	$L=0.1\text{mH}$	84***	mJ

Note : * Repetitive rating ; pulse width limited by junction temperature
 ** Drain current is limited by junction temperature
 *** Limited by T_{Jmax} , starting $T_J=25^{\circ}\text{C}$, $L = 0.1\text{mH}$, $V_{DS} = 48\text{V}$, $V_{GS} = 10\text{V}$.

Electrical Characteristics ($T_C = 25^{\circ}\text{C}$ Unless Otherwise Noted)

Symbol	Parameter	Test Conditions	HY1106			Unit
			Min.	Typ.	Max.	
Static Characteristics						
BV_{DSS}	Drain-Source Breakdown Voltage	$V_{GS}=0\text{V}$, $I_{DS}=250\mu\text{A}$	60	-	-	V
I_{DSS}	Zero Gate Voltage Drain Current	$V_{DS}=60\text{V}$, $V_{GS}=0\text{V}$ $T_J=85^{\circ}\text{C}$	-	-	1	μA
			-	-	30	
$V_{GS(th)}$	Gate Threshold Voltage	$V_{DS}=V_{GS}$, $I_{DS}=250\mu\text{A}$	1.0	2.0	3.0	V
I_{GSS}	Gate Leakage Current	$V_{GS}=\pm 20\text{V}$, $V_{DS}=0\text{V}$	-	-	± 100	nA
$R_{DS(ON)}$ *	Drain-Source On-state Resistance	$V_{GS}=10\text{V}$, $I_{DS}=11\text{A}$	-	12	15	$\text{m}\Omega$
		$V_{GS}=4.5\text{V}$, $I_{DS}=8\text{A}$		13.5	17	$\text{m}\Omega$
Diode Characteristics						
V_{SD} *	Diode Forward Voltage	$I_{SD}=1\text{A}$, $V_{GS}=0\text{V}$	-	0.7	1.0	V
t_{rr}	Reverse Recovery Time	$I_{DS}=11\text{A}$, $dI_{SD}/dt=100\text{A}/\mu\text{s}$	-	15	-	ns
Q_{rr}	Reverse Recovery Charge		-	55	-	nC

Electrical Characteristics (Cont.) ($T_c = 25^\circ\text{C}$ Unless Otherwise Noted)

Symbol	Parameter	Test Conditions	HY1106			Unit
			Min.	Typ.	Max.	
Dynamic Characteristics						
R_G	Gate Resistance	$V_{GS}=0V, V_{DS}=0V, F=1\text{MHz}$	-	1.0	-	Ω
C_{iss}	Input Capacitance	$V_{GS}=0V,$ $V_{DS}=25V,$ Frequency=1.0MHz	-	2286	-	pF
C_{oss}	Output Capacitance		-	188	-	
C_{rss}	Reverse Transfer Capacitance		-	142	-	
$t_{d(ON)}$	Turn-on Delay Time	$V_{DD}=30V, R_G=6\Omega,$ $I_{DS}=11A, V_{GS}=10V,$	-	8	-	ns
T_r	Turn-on Rise Time		-	4	-	
$t_{d(OFF)}$	Turn-off Delay Time		-	27	-	
T_f	Turn-off Fall Time		-	3	-	
Gate Charge Characteristics						
Q_g	Total Gate Charge	$V_{DS}=48V, V_{GS}=10V,$ $I_{DS}=11A$	-	52.5	-	nC
Q_{gs}	Gate-Source Charge		-	6.4	-	
Q_{gd}	Gate-Drain Charge		-	15.3	-	

Note * : Pulse test ; pulse width $\leq 300\mu\text{s}$, duty cycle $\leq 2\%$.

Typical Operating Characteristics

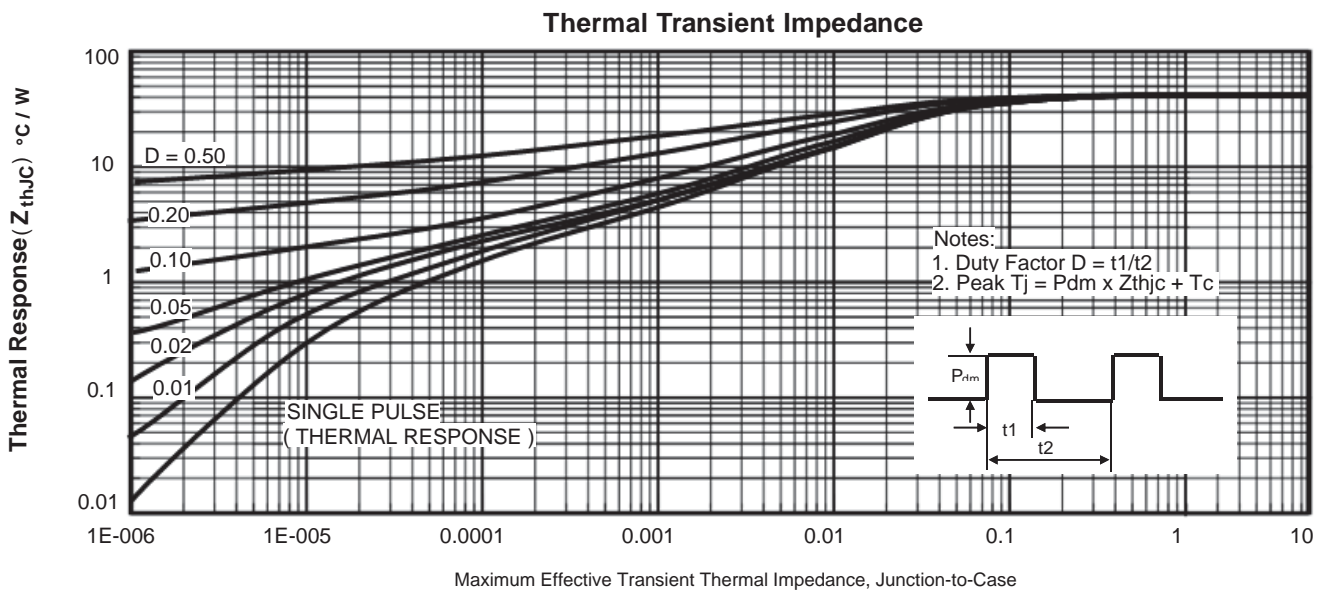
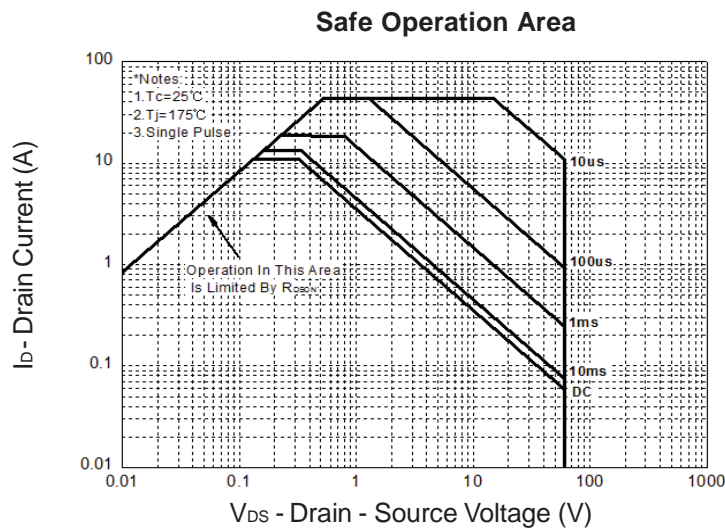
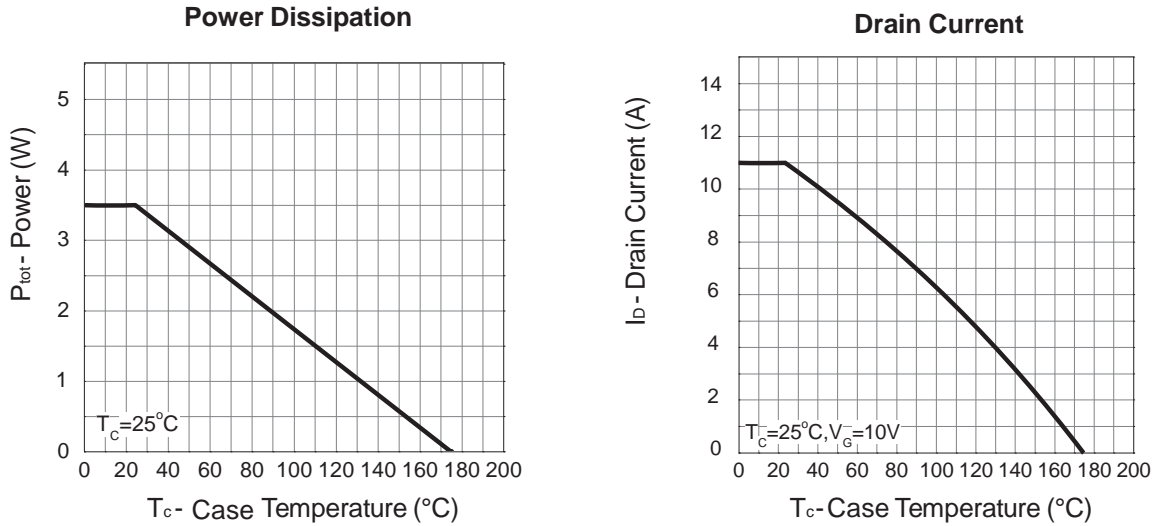

Typical Operating Characteristics (Cont.)

Output Characteristics

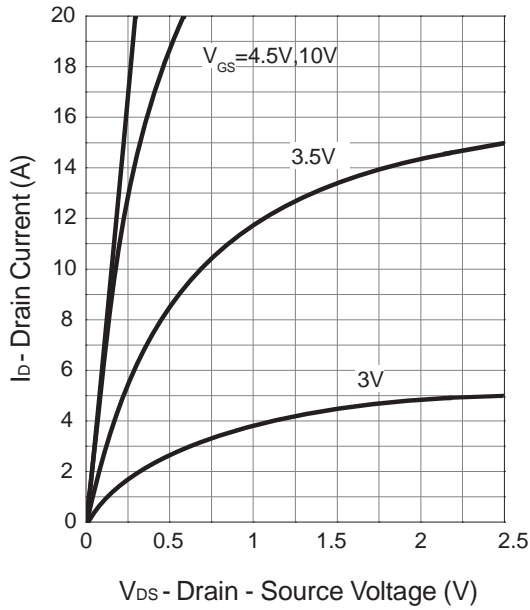

Drain-Source On Resistance

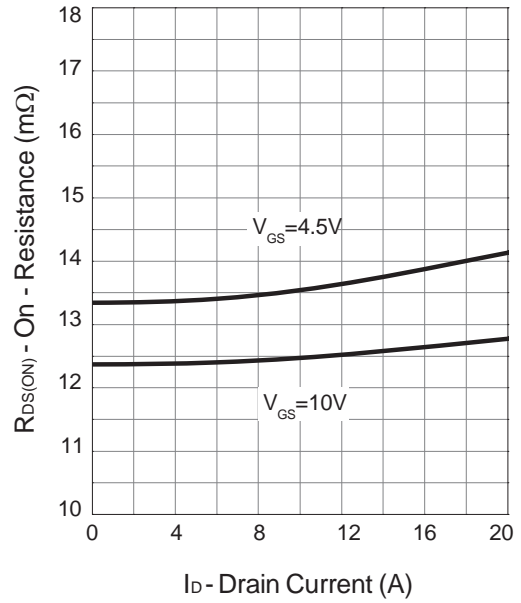

Gate-Source On Resistance

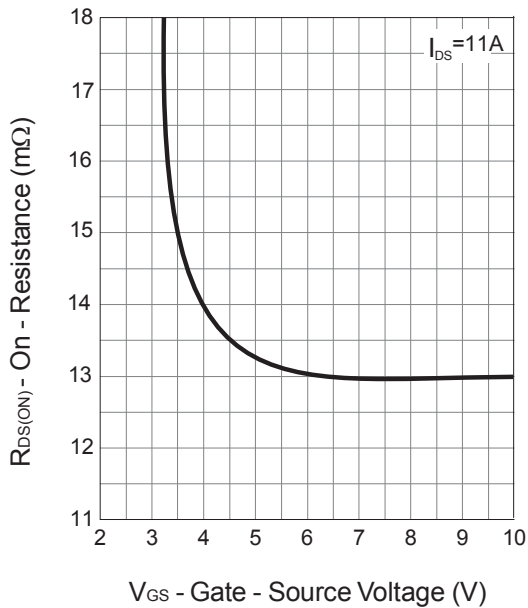

Gate Threshold Voltage

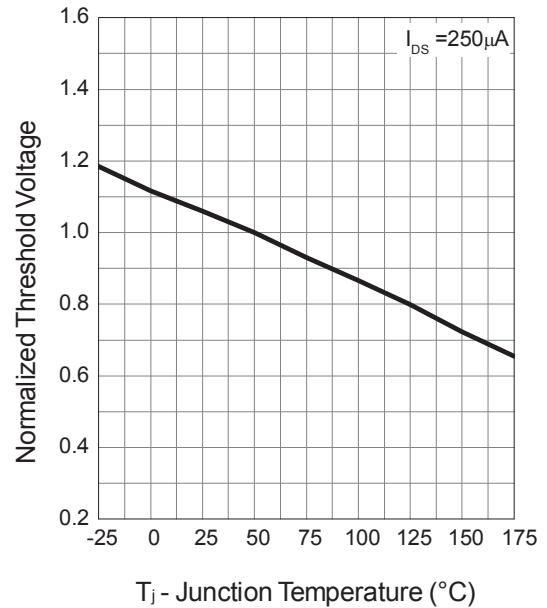

Typical Operating Characteristics (Cont.)

Drain-Source On Resistance

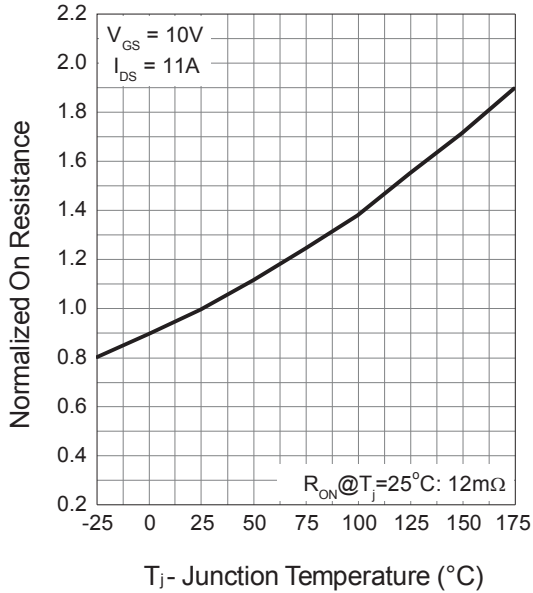

Source-Drain Diode Forward

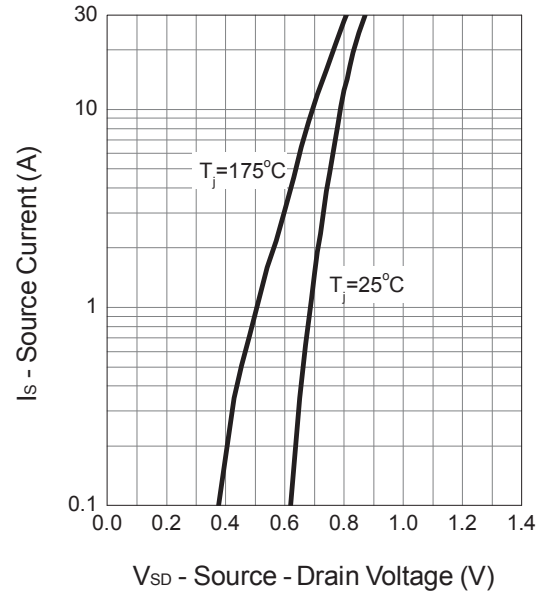

Capacitance

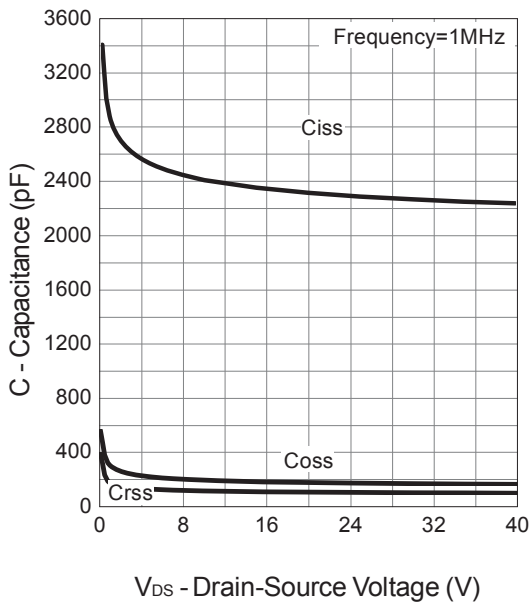

Gate Charge

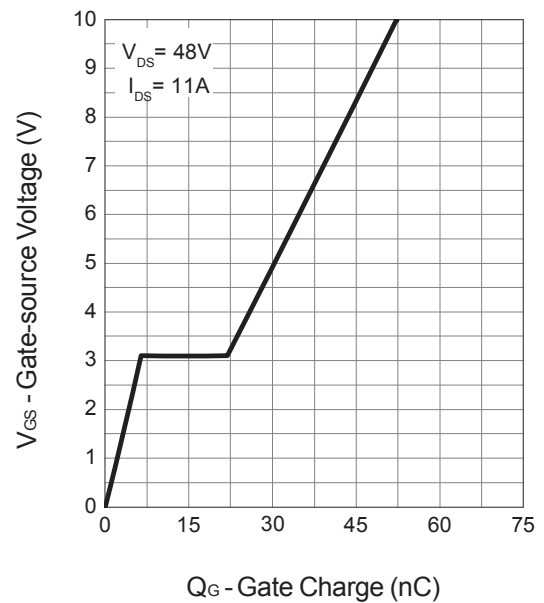

Avalanche Test Circuit

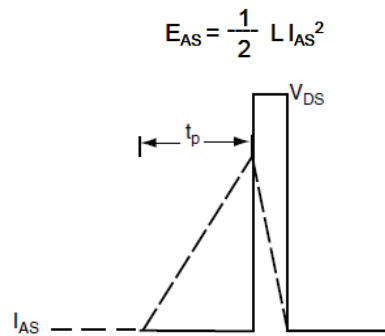
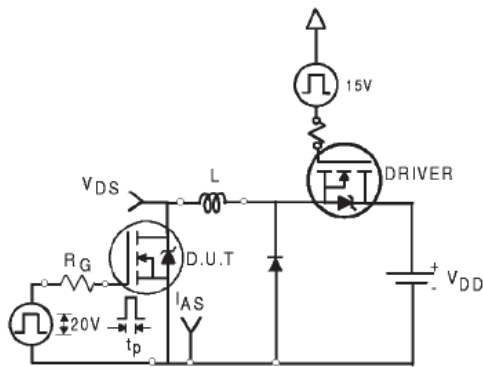

Switching Time Test Circuit

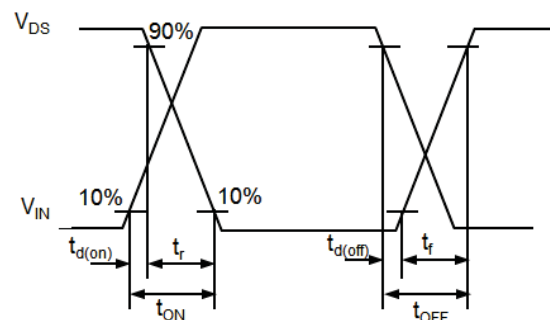
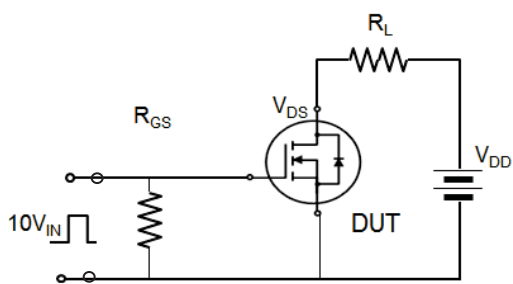

Gate Charge Test Circuit

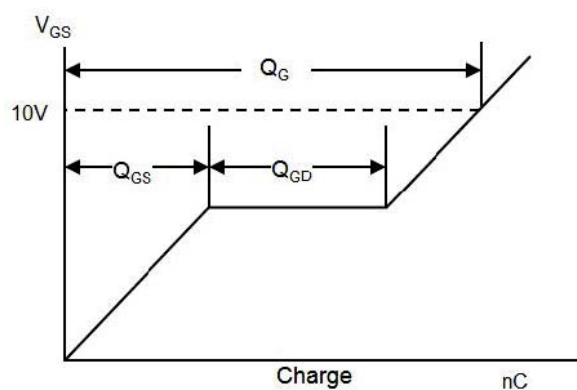
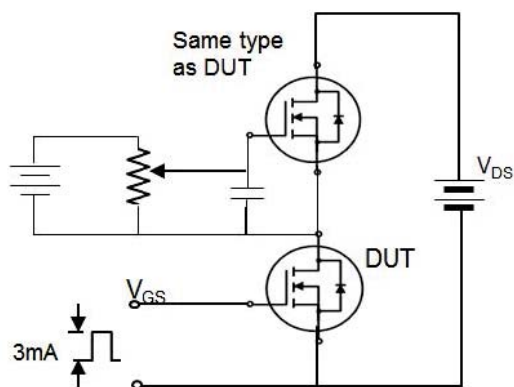

Package Information

SOP-8

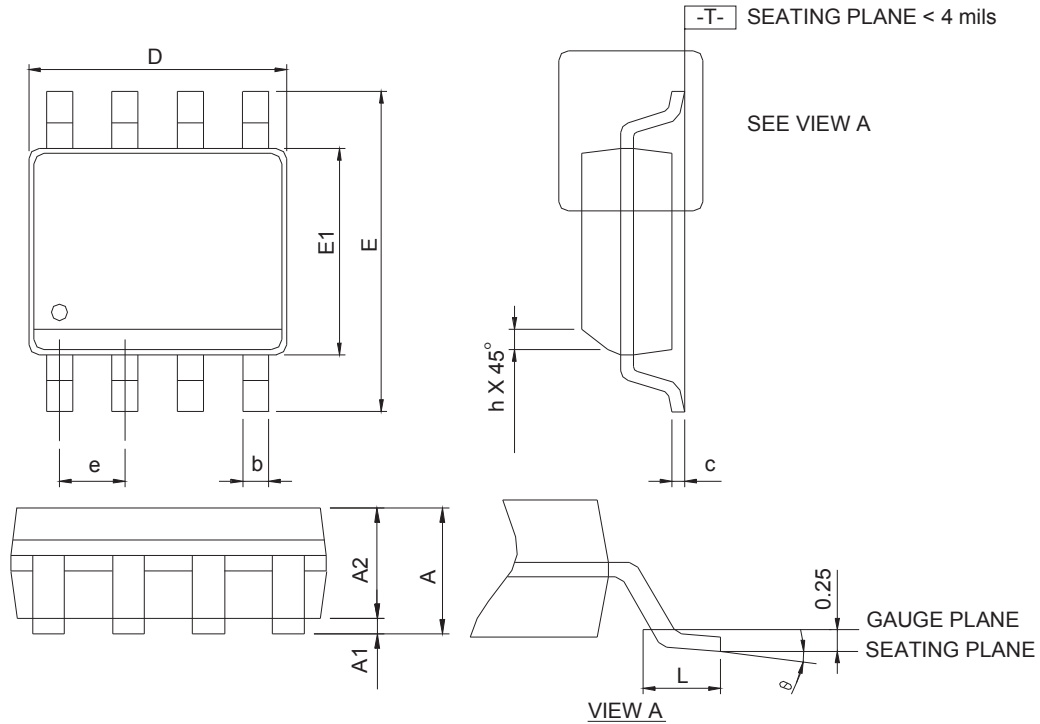

DIMENSIONS	SOP-8			
	MILLIMETERS		INCHES	
	MIN.	MAX.	MIN.	MAX.
A	-	1.75	-	0.069
A1	0.10	0.25	0.004	0.010
A2	1.25	-	0.049	-
b	0.31	0.51	0.012	0.020
c	0.17	0.25	0.007	0.010
D	4.80	5.00	0.189	0.197
E	5.80	6.20	0.228	0.244
E1	3.80	4.00	0.150	0.157
e	1.27 BSC		0.050 BSC	
h	0.25	0.50	0.010	0.020
L	0.40	1.27	0.016	0.050
θ	0°	8°	0°	8°

RECOMMENDED LAND PATTERN

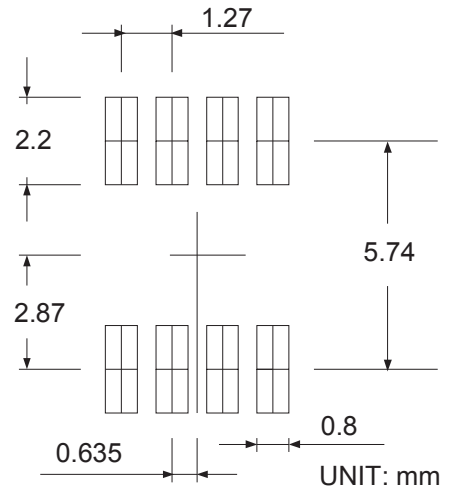

- Note: 1. Follow JEDEC MS-012 AA.
 2. Dimension "D" does not include mold flash, protrusions or gate burrs. Mold flash, protrusion or gate burrs shall not exceed 6 mil per side.
 3. Dimension "E" does not include inter-lead flash or protrusions. Inter-lead flash and protrusions shall not exceed 10 mil per side.

Carrier Tape & Reel Dimensions

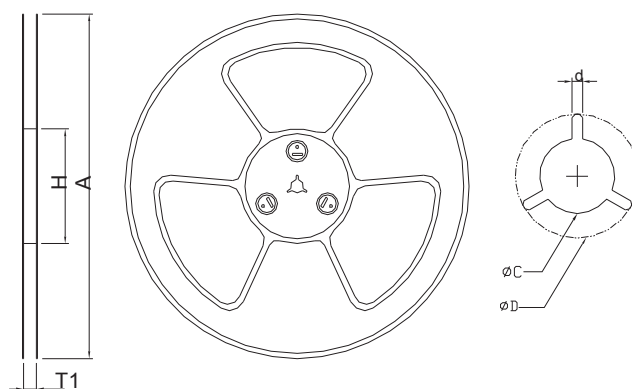
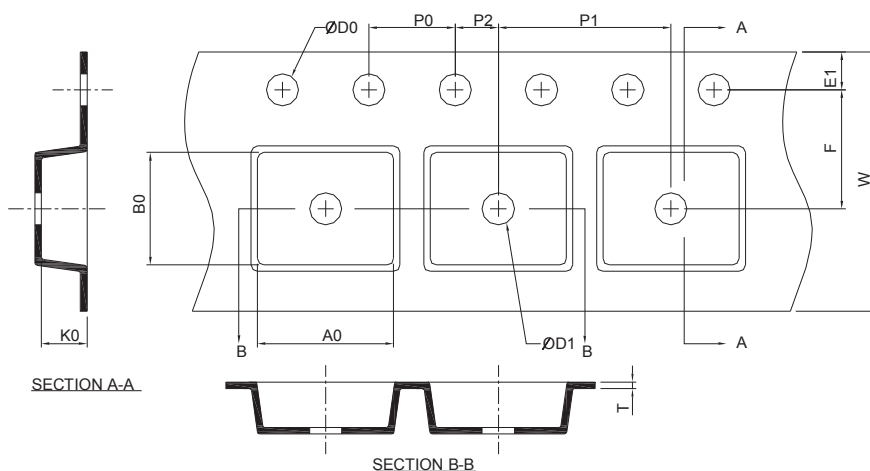

Application	A	H	T1	C	d	D	W	E1	F
SOP-8	330.0 2.00	50 MIN.	12.4+2.00 -0.00	13.0+0.50 -0.20	1.5 MIN.	20.2 MIN.	12.0 0.30	1.75 0.10	5.5 0.05
	P0	P1	P2	D0	D1	T	A0	B0	K0
	4.0 0.10	8.0 0.10	2.0 0.05	1.5+0.10 -0.00	1.5 MIN.	0.6+0.00 -0.40	6.40 0.20	5.20 0.20	2.10 0.20

(mm)

Devices Per Unit

Package Type	Unit	Quantity
SOP-8L	Reel	2500

Taping Direction Information

SOP-8

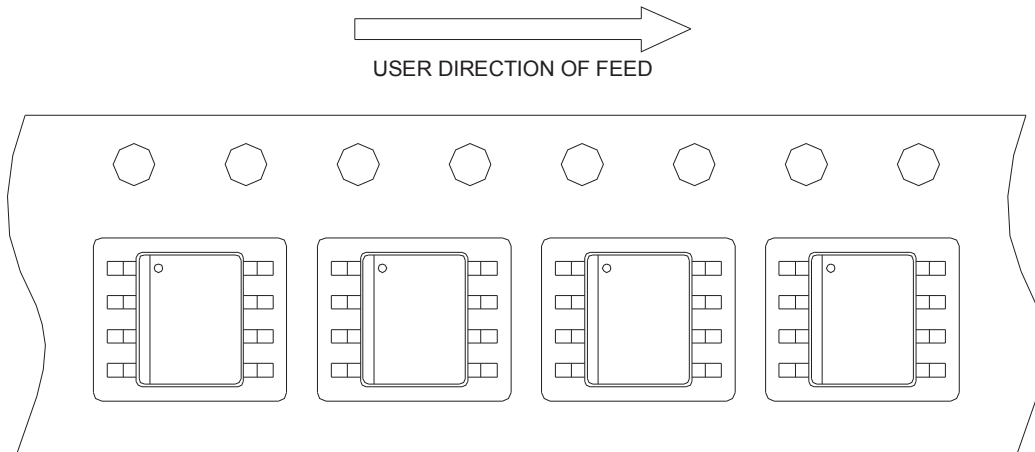

Classification Profile

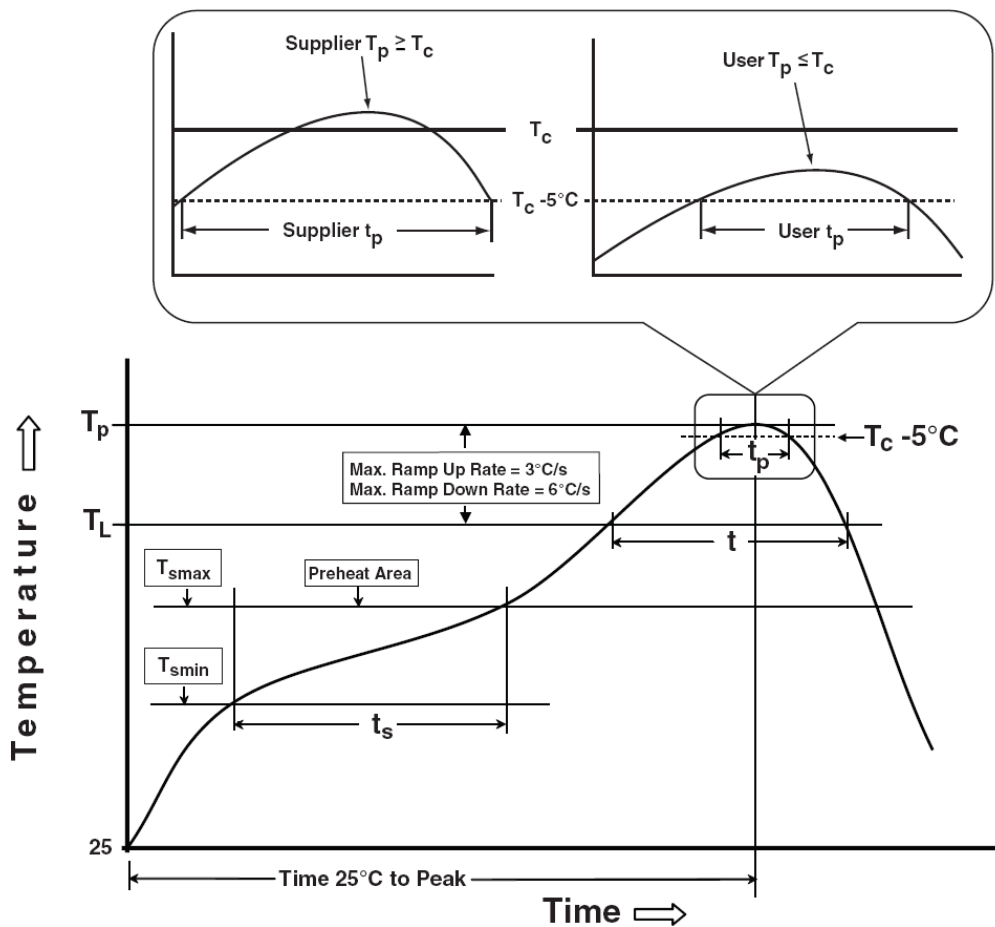

Classification Reflow Profiles

Profile Feature	Sn-Pb Eutectic Assembly	Pb-Free Assembly
Preheat & Soak		
Temperature min (T_{smin})	100 °C	150 °C
Temperature max (T_{smax})	150 °C	200 °C
Time (T_{smin} to T_{smax}) (t_s)	60-120 seconds	60-120 seconds
Average ramp-up rate (T_{smax} to T_P)	3 °C/second max.	3°C/second max.
Liquidous temperature (T_L)	183 °C	217 °C
Time at liquidous (t_L)	60-150 seconds	60-150 seconds
Peak package body Temperature (T_P)*	See Classification Temp in table 1	See Classification Temp in table 2
Time (t_P)** within 5°C of the specified classification temperature (T_c)	20** seconds	30** seconds
Average ramp-down rate (T_P to T_{smax})	6 °C/second max.	6 °C/second max.
Time 25°C to peak temperature	6 minutes max.	8 minutes max.
* Tolerance for peak profile Temperature (T_P) is defined as a supplier minimum and a user maximum.		
** Tolerance for time at peak profile temperature (t_P) is defined as a supplier minimum and a user maximum.		

Table 1. SnPb Eutectic Process – Classification Temperatures (T_c)

Package Thickness	Volume mm ³ <350	Volume mm ³ ≥350
<2.5 mm	235 °C	220 °C
≥2.5 mm	220 °C	220 °C

Table 2. Pb-free Process – Classification Temperatures (T_c)

Package Thickness	Volume mm ³ <350	Volume mm ³ 350-2000	Volume mm ³ >2000
<1.6 mm	260 °C	260 °C	260 °C
1.6 mm – 2.5 mm	260 °C	250 °C	245 °C
≥2.5 mm	250 °C	245 °C	245 °C

Reliability Test Program

Test item	Method	Description
SOLDERABILITY	JESD-22, B102	5 Sec, 245°C
HTRB	JESD-22, A108	168 Hrs/500 Hrs/1000 Hrs, 80% of VDS max @150°C
HTGB	JESD-22, A108	168 Hrs/500 Hrs/1000 Hrs, 100% of VGS max @150°C
PCT	JESD-22, A102	96 Hrs, 100%RH, 2atm, 121°C
TCT	JESD-22, A104	500 Cycles, -55°C~150°C

Customer Service

Worldwide Sales and Service: sales@hymexa.com

Technical Support:Technology@hymexa.com

Xi'an Huayi Microelectronics Co., Ltd.

No.8928,Shangji Road,Economic and Technological Development Zone,Xi'an,China

TEL: (86-029) 86685706

FAX: (86-029) 86685705

E-mail: sales@hymexa.com

Web net: www.hymexa.com