

POWER MANAGEMENT

Primary Side Control CC/CV Controller

Features

- Constant-Current (CC) and Constant-Voltage (CV) Control with Primary Side Control
- $\pm 5\%$ Constant Voltage Regulation
- $\pm 10\%$ Constant Current Regulation
- Eliminates Opto-Coupler and TL431
- External Power NPN Transistor for Low Cost
- Operation Frequency Modulation Improve System EMI
- Built-in Line Compensation
- Cycle-by-Cycle Current Limiting
- Over Voltage Protection (OVP)
- Over Temperature Protection (OTP)
- Open Circuit Protection
- Short Circuit Protection
- Pb-Free Device

TYPICAL APPLICATION

- Adapter/Charger for Cell/Cordless Phones,
- PDAs, MP3 and Other Portable Apparatus
- Standby and Auxiliary Power Supplies
- Set Top Boxes (STB)
- LED Driver

The 3653A controller device is optimized for low cost, low power switching mode power supply applications that not needed cable compensation . The 3653A facilitates CC/CV charger design by eliminating an opto-coupler and TL431. Its highly integrated functions such as Under Voltage Lockout (UVLO), Leading Edge Blanking (LEB), Built-in line compensation and Cycle-by-Cycle current limiting offer the users a high efficiency and low cost solution for AC/DC power applications.

Furthermore, 3653A features fruitful protections like OTP (Over Temperature Protection), OVP (Over Voltage Protection), and Open Circuit Protection, Short Circuit Protection to eliminate the external protection circuits and provide reliable operation. ART3653A is available in SOT23-5 packages.

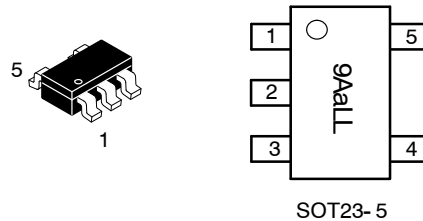
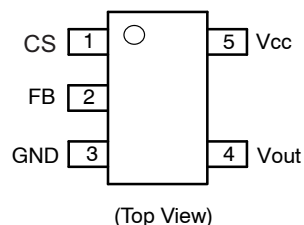

9Aa : Product code
LL : Lot code or datecode abbreviation (From A~Z)

ORDERING INFORMATION

Device	Marking Code	Package	Shipping [†]
ART3653A	9AaLL	SOT23-5	3000 / Tape & Reel

ELECTRICAL CHARACTERISTICS

(For typical values Tj=25°C, Vcc=10V, unless otherwise noted)

Characteristic	Symbol	Min	Typ	Max	Unit
Current Sense					
Maximum Current Threshold	Vcs_max	0.49	0.5	0.51	V
Pre-drive Current Threshold	Vcs_pre	0.44	0.45	0.46	V
Vcs_limit Temperature Stability (-40°C~125°C)			1		%
Leading Edge Blanking Duration	Tleb		400		ns
Propagation Delay (OUT=1.0nF to GND)	Tpd			200	ns
Feedback Section					
Feedback Voltage Threshold	Vfb	2.97	3	3.03	V
FB Pin minimum current	Ifb_open		50		μA
OVP Protection Threshold Level	Vovp	4.55	4.65	4.75	V
CCM protection Threshold Level	Vcp		0.1		V
Supply Section					
Start Up Threshold Voltage	Vcc_on	13.5	15	17.2	V
Under Voltage Lockout Voltage	Vcc_off	4.8	5.4	6	V
VCC Start Up Current	Istart_up		6		uA
Operating Current	Iop		1.1		mA
Protection Section					
Feedback Loop Open Protection	Ifb_open		150		uA
Over Temperature Protection	Tsd		140		°C
Base Driver					
Output Maximum Sink current	Isink	50			mA
Output Maximum Source current			30		mA
Compensation					
Line Compensation (Ifb=1mA)	Vline		45		mV
Driver Input Characteristics					
AC Input Voltage Rating	Vac	90		264	V
AC Input Frequency		50		60	Hz
Environmental					
Operating Temperature		-10		+85	°C
Storage Temperature		-40		+125	°C
Operating Frequency			47		kHz

TYPICAL APPLICATION CIRCUIT

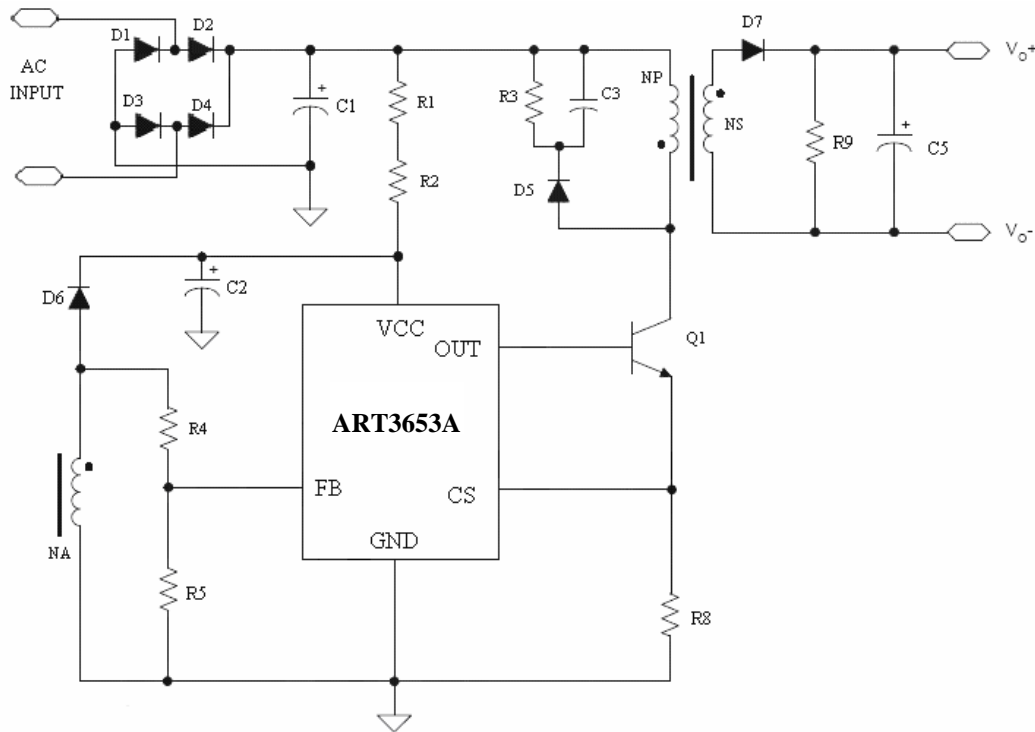

Figure 1: Typical Application Circuit

ABSOLUTE MAXIMUM RATINGS

FB to GND.....	-0.3V to +9V
CS to GND.....	-0.3V to +9V
VCC to GND.....	-0.3V to +18V
OUT to GND.....	-0.3V to +9V
Operating Temperature Range.....	-40°C to +125°C
Junction Temperature.....	-40°C to +150°C
Storage Temperature Range	-60°C to +150°C
ESD Protection HBM.....	2000V
MM.....	500V

Stresses exceeding Maximum Ratings may damage the device. Maximum Ratings are stress ratings only. Functional operation above the Recommended Operating Conditions is not implied. Extended exposure to stresses above the Recommended Operating Conditions may affect device reliability.

BLOCK DIAGRAM

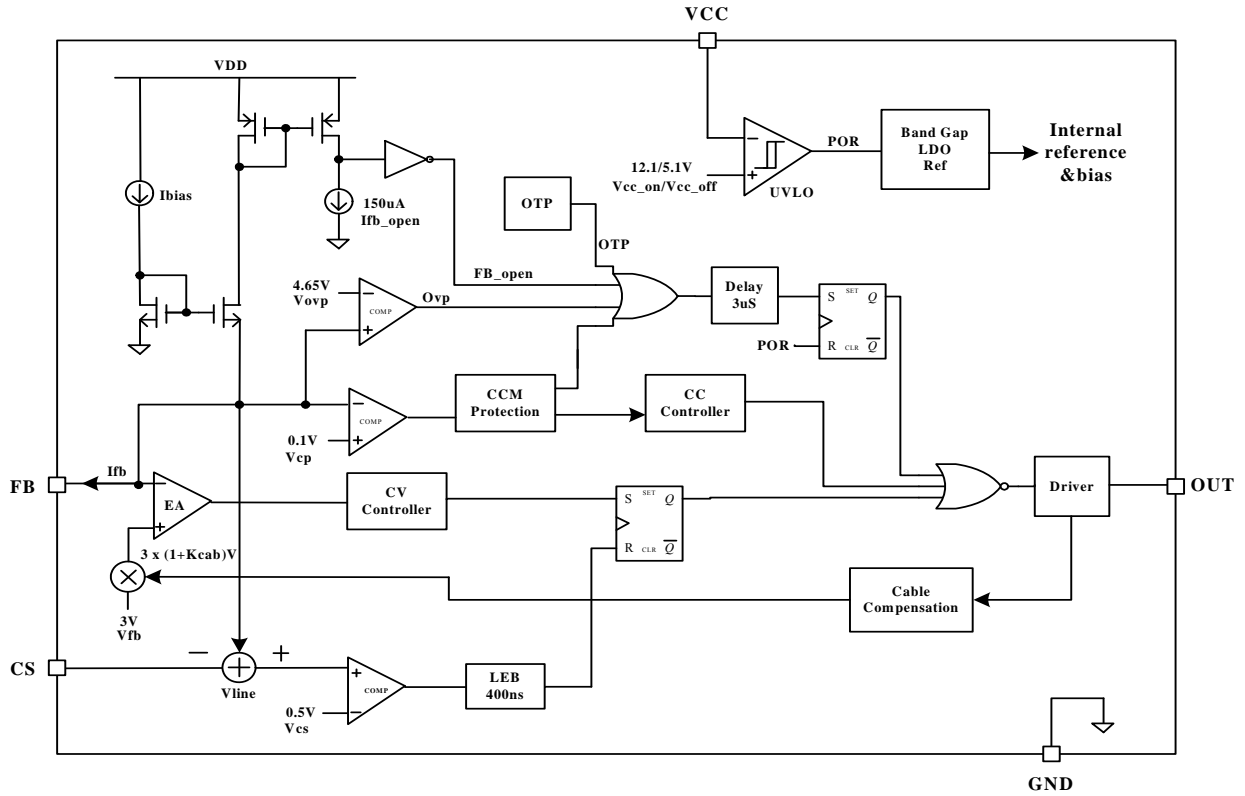
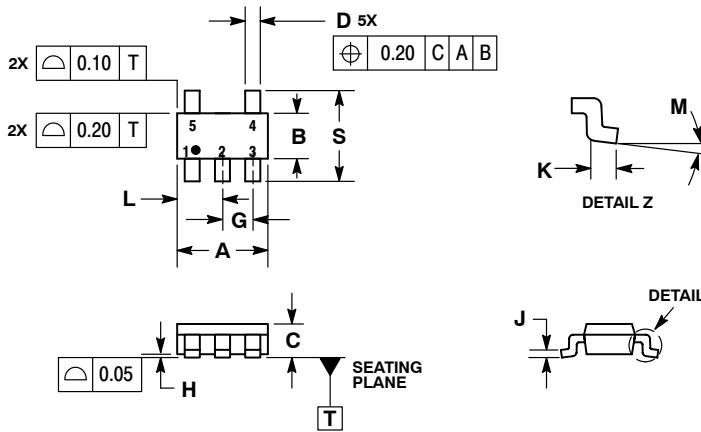

Figure 4: ART3653A Block Diagram

PACKAGE INFORMATION



NOTES:

1. DIMENSIONING AND TOLERANCING PER ASME Y14.5M, 1994.
2. CONTROLLING DIMENSION: MILLIMETERS.
3. MAXIMUM LEAD THICKNESS INCLUDES LEAD FINISH THICKNESS. MINIMUM LEAD THICKNESS IS THE MINIMUM THICKNESS OF BASE MATERIAL.
4. DIMENSIONS A AND B DO NOT INCLUDE MOLD FLASH, PROTRUSIONS, OR GATE BURRS.
5. OPTIONAL CONSTRUCTION: AN ADDITIONAL TRIMMED LEAD IS ALLOWED IN THIS LOCATION. TRIMMED LEAD NOT TO EXTEND MORE THAN 0.2 FROM BODY.

DIM	MILLIMETERS	
	MIN	MAX
A	3.00 BSC	
B	1.50 BSC	
C	0.90	1.10
D	0.25	0.50
G	0.95 BSC	
H	0.01	0.10
J	0.10	0.26
K	0.20	0.60
L	1.25	1.55
M	0°	10°
S	2.50	3.00

SOLDERING FOOTPRINT*

