



Linear Technology Corporation

1630 McCarthy Blvd.
Milpitas, CA 95035-7417
Tel: 408-432-1900

www.linear.com

WF08098KU

VOL 3

Telecom, Datacom and Industrial Power Products

High Performance Analog ICs



Contents

Page Description

Simplified DC/DC Conversion Block Diagrams

- 01 Isolated Block Diagram
- 02 Nonisolated Block Diagram

Hot Swap™/Ideal Diode Controllers

- 03 Overvoltage Protection Regulator and Inrush Current Limiter
- 04–05 Hot Swap Controllers
- 06–08 Ideal Diode Controllers
- 07 48V Fuse Monitor

Isolated DC/DC Conversion

- 09–10 Flyback Controllers
- 10–11 Forward Controllers/Smart Drivers
- 12 Demonstration Boards – Telecom/Datacom (18V to 75V)
- 13 Industrial Power Conversion (9V to 36V)
- 14–15 Push-Pull, Half- and Full-Bridge Controllers

Nonisolated DC/DC Conversion, Up to 100V Input

- 16 Buck and Boost High Voltage Controllers
- 17 Forward Controllers
- 18 Buck-Boost μ Module® Regulators and Controllers
- 19 Monolithic Buck Regulators/Linear Regulators
- 20 MOSFET Drivers/Opto Drivers/Reference Voltage

PoE, Interface, System Monitoring and Control

- 21 Power over Ethernet Controllers
- 22–23 Rugged Serial Interface Transceivers
- 24 I²C and SMBus Buffers and Accelerators
- 25 Voltage Monitors and Supervisors
- 25 Pushbutton Controllers
- 26 Coulomb Counter/Battery Gas Gauge
- 27 High Voltage I²C Current and Voltage Monitor
- 28 Supply Trackers, Sequencers and Margining Controllers

Isolated DC/DC Conversion

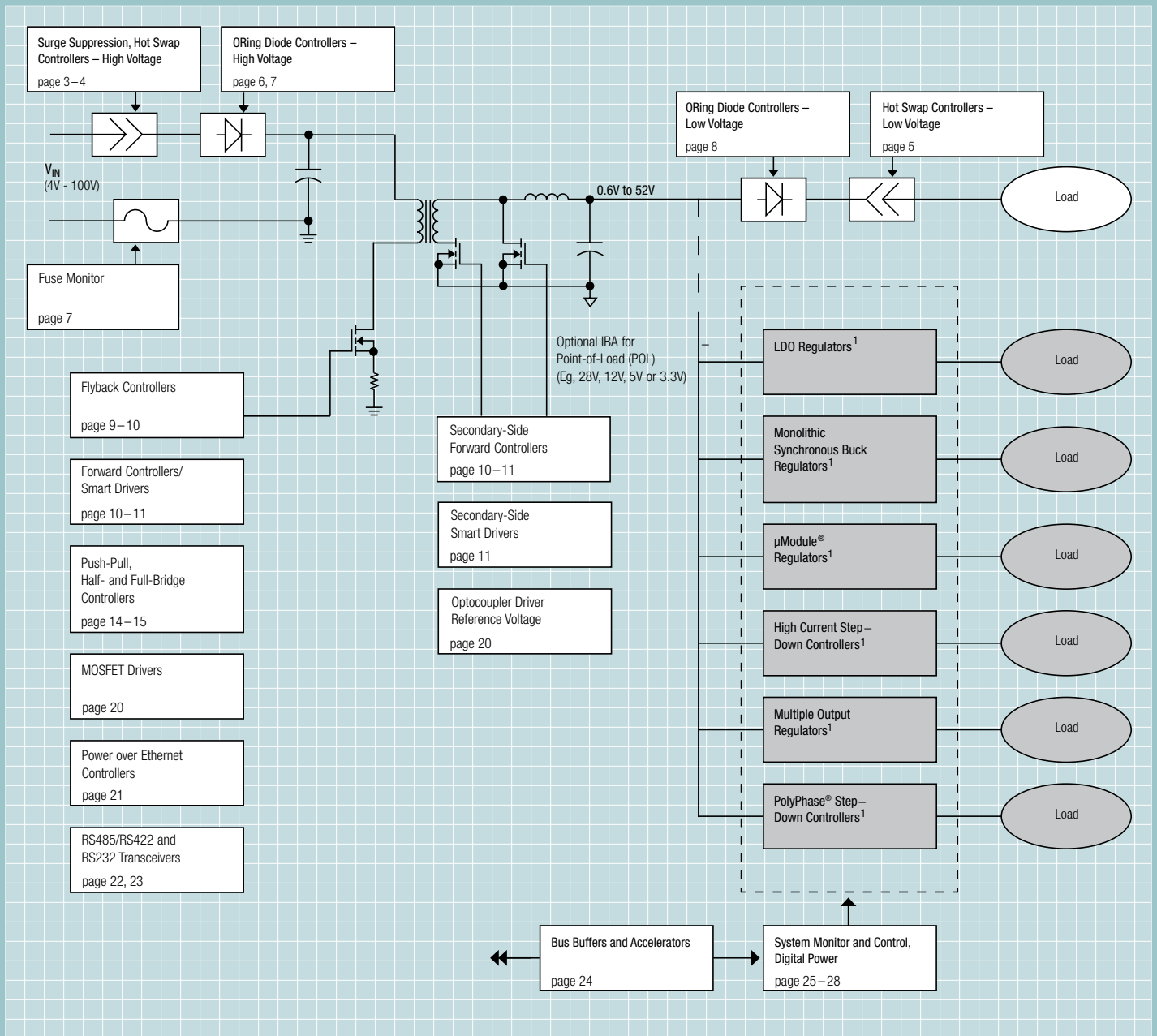

¹ For descriptions of these products, visit www.linear.com.

Nonisolated DC/DC Conversion

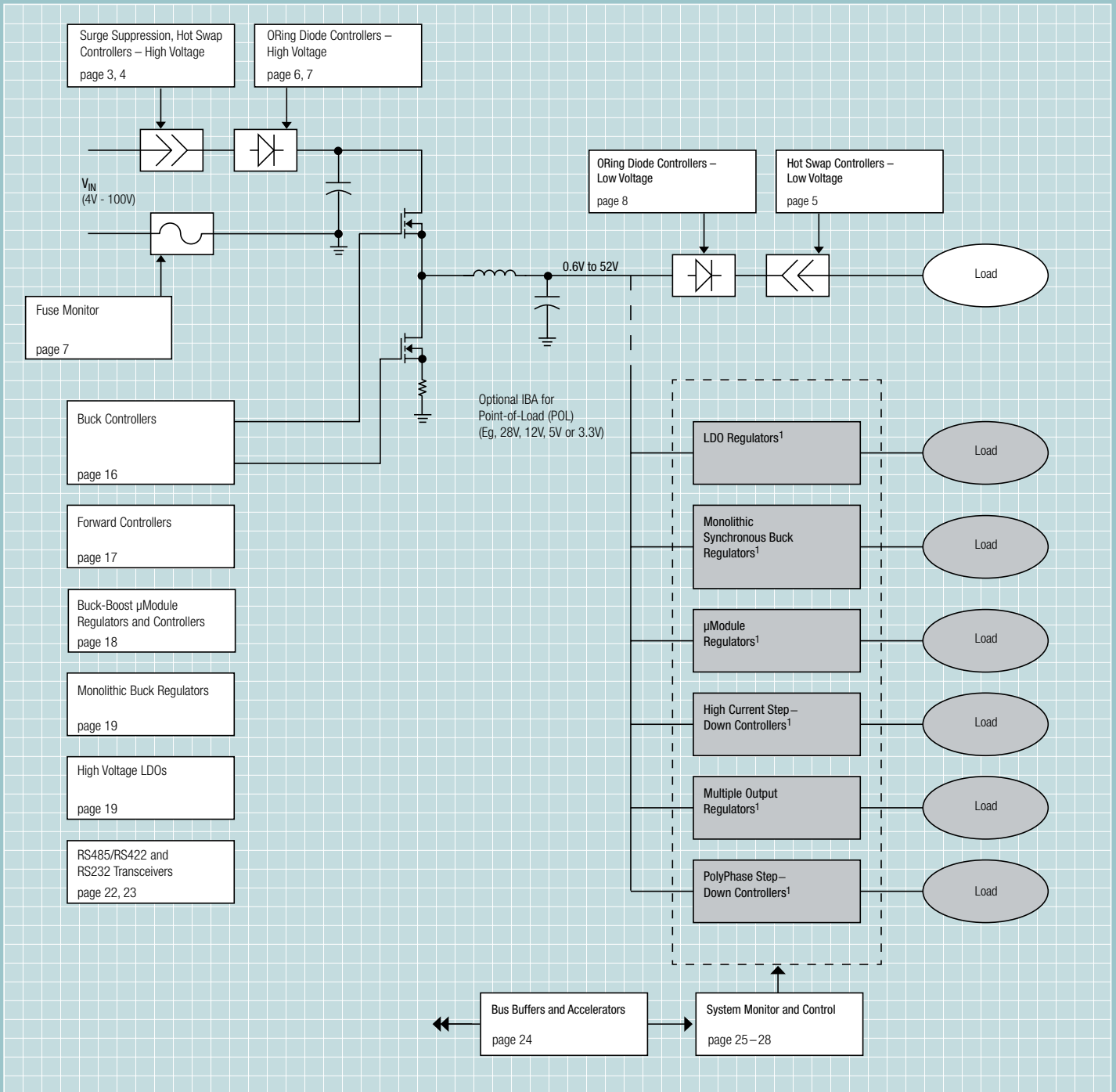

¹For descriptions of these products, visit www.linear.com.

LT4356 Surge Stopper: Overvoltage Protection Regulator and Inrush Current Limiter

In industrial applications, high voltage power supply spikes with durations ranging from a few microseconds to hundreds of milliseconds are commonly encountered. The electronics in these systems must not only survive transient voltage spikes, but in many cases also operate reliably throughout the event.

The LT[®]4356 Surge Stopper reduces the need for bulky filtering components (capacitors, inductors, TVS diodes, fuses) by isolating low voltage circuitry from damaging spikes and surges found in industrial systems. The LT4356 offers complete front end protection, guards against overloads and short circuits, and withstands input voltage reversal with a simple IC/MOSFET solution. The LT4356 also protects against DC overvoltage and overcurrent, which ordinary surge suppressors cannot do.

Under normal conditions, the LT4356 drives the MOSFET fully on, so that input power passes through directly to the load, with very little loss. If the input voltage rises above an adjustable output threshold, the LT4356 regulates the output at a safe level. The regulating action eliminates the need to use high voltage rated components downstream. Instead, less costly components may be used, because the LT4356 blocks high voltages from reaching them.

The LT4356 provides the ability to ride out transients for continued system operation. If the fault persists, an adjustable timer sets a time limit to ensure the MOSFET stays within its operating limits before the load is disconnected and the system is shut down. The timer capacitor is charged with a current proportional to the voltage drop, V_{ds} . For an overcurrent fault, the timer charging current is increased. This unique feature takes more advantage of the Safe Operating Area (SOA) of the MOSFET than would a fixed timer interval, allowing the user to size the MOSFET appropriately for their surge requirements.

LT4356 Features:

- Stops High Voltage Surges
- Adjustable Output Clamp Voltage
- Overcurrent Protection
- Wide Operation Range: 4V to 80V
- Reverse Input Protection to -60V
- Low 7 μ A Shutdown Current, LT4356-1/LT4356-3
- Adjustable Fault Timer
- Inrush Current Limiting
- Controls N-Channel MOSFET
- Shutdown Pin Withstands -60V to 100V
- Fault Output Indication
- Spare Amplifier for Level Detection Comparator or Linear Regulator Controller
- Guaranteed Operation to 125°C
- Latchoff Operation (LT4356-3)
- Automatic Retry (LT4356-1, LT4356-2)
- Available in (4mm \times 3mm) 12-Pin DFN, 10-Pin MSOP or 16-Pin SO Packages

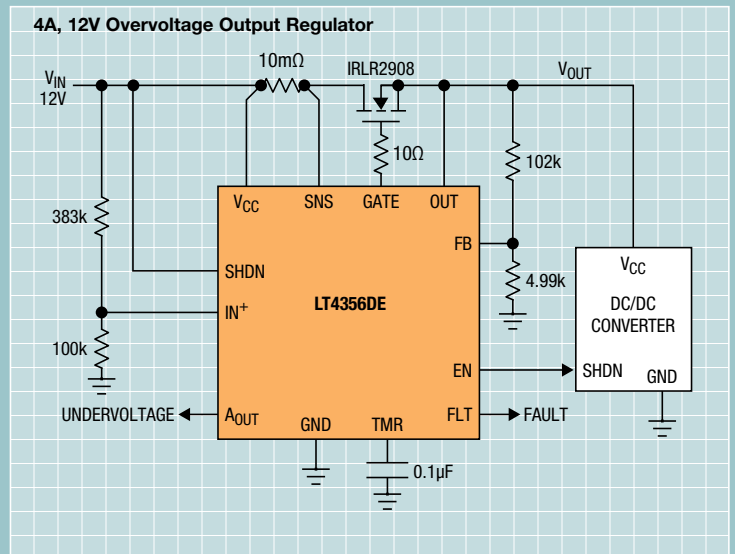

Overvoltage Protection Regulates Output at 27V During Transient

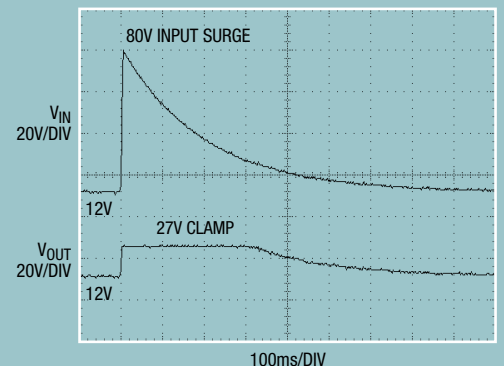

Hot Swap Controllers – High Voltage

Hot Swap controllers allow a circuit board to be safely inserted and removed from a live backplane. Using an N-channel pass MOSFET, the board supply voltage can be ramped at an adjustable rate. Product features include independent adjustable inrush current and overcurrent limits to minimize stresses on the pass MOSFET during start-up, input step, and output step short-circuit conditions. Newer generation devices include an onboard ADC for board voltage and current monitoring, and an I²C interface for microcontroller interaction.

LTC[®]4260: Positive High Voltage Hot Swap Controller with I²C Compatible Monitoring

Features:

- Allows Safe Insertion into Live Backplane
- 8-Bit ADC Monitors Current and Voltage
- I²C/SMBus Interface
- Wide Operating Voltage Range: 8.5V to 80V
- High Side Drive for External N-Channel MOSFET
- Input Overvoltage/Undervoltage Protection
- Optional Latchoff or Autoretry After Faults
- Alerts Host After Faults
- Foldback Current Limiting

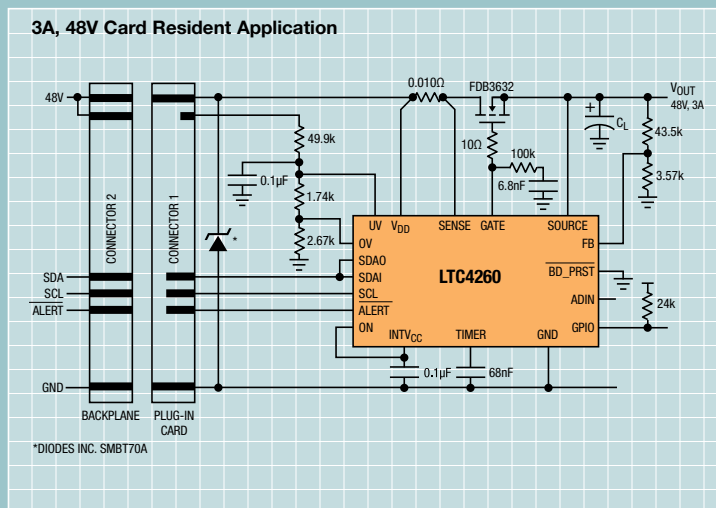

Part Number	Input Voltage Range	Inrush Control	Overcurrent Control	UV	OV	Fault Output	PWRGD/Reset	Description	Package
High Voltage Hot Swap Controllers									
LT4250	-18V to -80V	Ramp	ACL ¹	Yes	Yes		Yes	LT1640A Pin-Compatible with Active Current Limiting	SO-8
LTC4252A-1/2	-15V to -100V (Floating)	Active or Ramp	ACL ¹	Yes	Yes		Yes	Soft-Start Limits Inrush dI/dt Drain Accelerated Response. ±1% Undervoltage/Overvoltage Threshold Accuracy for AdvancedTCA Applications	MSOP-8 MSOP-10
LT4256-1/2/3	10.8V to 80V	Active or Ramp	ACL ¹	Yes	Yes		Yes	LT4256-1/2 Pin-Compatible Upgrade to LT1641. Open Circuit Detect Output. Latchoff/ Auto-Retry Operation	SO-8 SSOP-16
LTC4260	8.5V to 80V	Active or Ramp	ACL ¹	Yes	Yes	Yes	Yes	Onboard 8-Bit ADC for Card Voltage and Current Monitoring, I ² C Interface. Programmable Latchoff or Auto-Retry	5x5 QFN-32 SSOP-24 SO-24
LTC4261	-12V to -100V (Floating)	Ramp	ACL ¹	Yes	Yes	Yes	Delayed	Onboard 10-Bit ADC for Card Voltage and Current Monitoring, I ² C Interface. Programmable Latchoff or Auto-Retry	4x5 QFN-24 SSOP-28
LT4356-1/2/3	4V to 80V	Active or Ramp	ACL ¹			Yes	Yes	Surge Stopper: Overvoltage Protection and Inrush Limiting. Spare Amplifier for UV/OV Monitoring or Linear Regulator. Latchoff/Auto-Retry Operation	4x3 DFN-12 MSOP-10 SO-16

¹ACL = Active Current Limit

Hot Swap Controllers – Low Voltage

Low voltage Hot Swap controllers include independent high side gate drivers to control single or dual voltages, as well as voltage power-up and power-down ramp control, current foldback and inrush limiting. Our latest LTC4217 and LTC4218 Hot Swap products allow the current limit threshold to be adjusted dynamically using an external pin. Additional features include a current monitor output that amplifies the sense resistor voltage for ground referenced current sensing and a MOSFET temperature monitor output. Dedicated 12V versions contain preset 12V-specific thresholds.

LTC4215: Hot Swap Controller with I²C Compatible Monitoring

Features:

- Allows Safe Insertion into Live Backplane
- 8-Bit ADC Monitors Current and Voltage
- I²C/SMBus Interface
- Wide Operating Voltage Range: 2.9V to 15V
- dI/dt Controlled Soft-Start
- High Side Drive for External N-Channel MOSFET
- No External Gate Capacitor Required
- Input Overvoltage/Undervoltage Protection
- Optional Latchoff or Auto-Retry After Faults
- Alerts Host After Faults
- Inrush Current Limit with Foldback
- Available in 24-Lead (4mm × 5mm) QFN and 16-Lead Narrow SSOP Packages

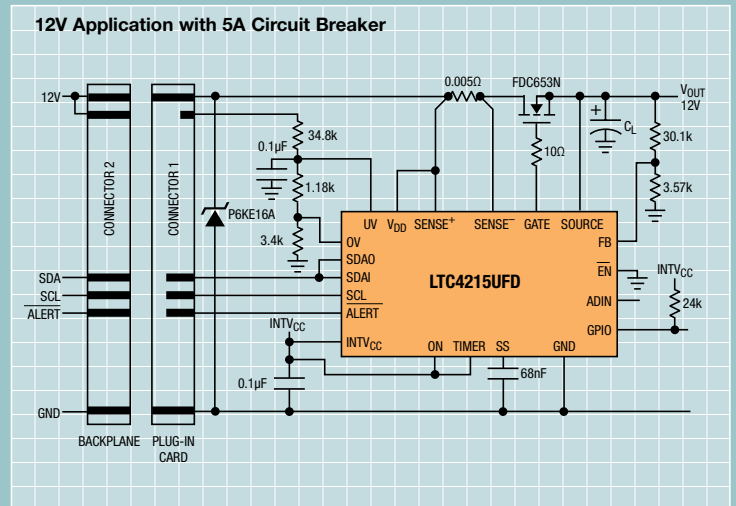

Part Number	Channels	Input Voltage Range	Inrush Control	Overcurrent Control	Fault Output	PWRGD/Reset	Description	Package
Low Voltage Hot Swap Controllers								
LTC4210-1/2/3/4	1	2.7V to 16.5V	Active or Ramp	ACL ¹	Yes		Active Current Limiting with a Circuit Breaker. Latchoff/Auto-Retry Operation	SOT-23
LTC4211	1	2.5V to 16.5V	Active or Ramp	ECB ²	Yes	Delayed	No Gate Capacitor Required	SO-8 MSOP-8 MSOP-10
LTC4215-1/2/3	1	2.9V to 16.5V	Active or Ramp	ACL ¹	Yes	Yes	I ² C/SMBus Interface, Internal 8-bit ADC, dI/dt Controlled Soft-Start	SSOP-16 4x5 QFN-24
LTC4216	1	0V to 6V	Active or Ramp	ACL ¹		Delayed	Ultralow Voltage Hot Swap Controller for 0V to 6V, with a Separate Supply of 2.3V to 6V. Adjustable Current Limit, Soft-Start and Response Time for Overcurrent Protection	MSOP-10 4x3 DFN-12
LTC4217/-12	1	2.9V to 26.5V	Active or Ramp	ACL ¹	Yes	Yes	Small Footprint 2A Hot Swap Controller. Integrated 33mΩ MOSFET and R _{SENSE} . Adjustable, 5% Accurate Current Limit. 2% Accurate Undervoltage and Overvoltage Protection. A Dedicated 12V Version (LTC4217-12) Contains Preset 12V Specific Thresholds	TSSOP-10 5x3 DFN-16
LTC4218/-12	1	2.9V to 26.5V	Active or Ramp	ACL ¹	Yes	Yes	Adjustable, 5% Accurate (15mV) Current Limit. 2% Accurate Undervoltage and Overvoltage Protection. A Dedicated 12V Version (LTC4218-12) Contains Preset 12V Specific Thresholds	SSOP-16 5x3 DFN-16
LTC4222	2	2.9V to 29V	Active or Ramp	ACL ¹		Yes	I ² C/SMBus Interface, Internal 10-bit ADC, dI/dt Controlled Soft-Start. Latchoff/Auto-Retry Operation	5x5 QFN-32 SSOP-36
LTC4223-1/2	2	10V to 14V 2.7V to 6V	Active or Ramp	ACL ¹	Yes	Yes	Controls 12V and 3.3V Auxiliary Supplies. Integrated 0.3Ω AUX Switch. Adjustable Current Limit with Circuit Breaker. Latchoff/Auto-Retry Operation	5x5 QFN-32 SSOP-36

¹ACL = Active Current Limit

²ECB = Electronic Circuit Breaker

ORing Ideal Diode Controllers

Linear's family of ideal diode controllers reduces forward voltage drop and power dissipation in ORing applications, eliminating the heat sinks required by conventional rectifiers. They deliver smooth switchover without chatter and are free from oscillation in load sharing applications, yet respond quickly when called upon to block DC current in the reverse state. Our controllers prevent backfeeding between supplies and are easily configured to protect against reverse polarity inputs.

Ideal Diode Controllers – High Voltage

LTC4354: Negative Voltage Diode-OR Controller and Monitor

The LTC4354 is a negative voltage and the LTC4355 is a positive voltage diode-OR controller that drive two external N-channel MOSFETs. Each replaces two Schottky diodes and the associated heat sink, saving power and space. The power dissipation is greatly reduced by using N-channel MOSFETs as the pass transistors. Power sources can be easily ORed together to increase total system power and reliability.

LTC4355: Positive High Voltage Dual Ideal Diode-OR with Input Supply and Fuse Monitors

The LTC4355 can diode-OR two positive supplies or the return paths of two negative supplies, such as in a -48V system. Power fault detection indicates if the input supplies are not in regulation, the inline fuses are blown, or the voltages across the MOSFETs are greater than the fault threshold.

Features:

- Replaces Power Schottky Diodes
- Controls N-Channel MOSFETs
- $0.5\mu\text{s}$ Turn-Off Time Limits Peak Fault Current
- Wide Operating Voltage Range: 9V to 80V
- Smooth Switchover without Oscillation
- No Reverse DC Current
- Monitors V_{IN} , Fuse and MOSFET Diode
- Available in 14-Lead (4mm \times 3mm) DFN, 16-Lead MS and SO Packages

Power Dissipation vs Load Current

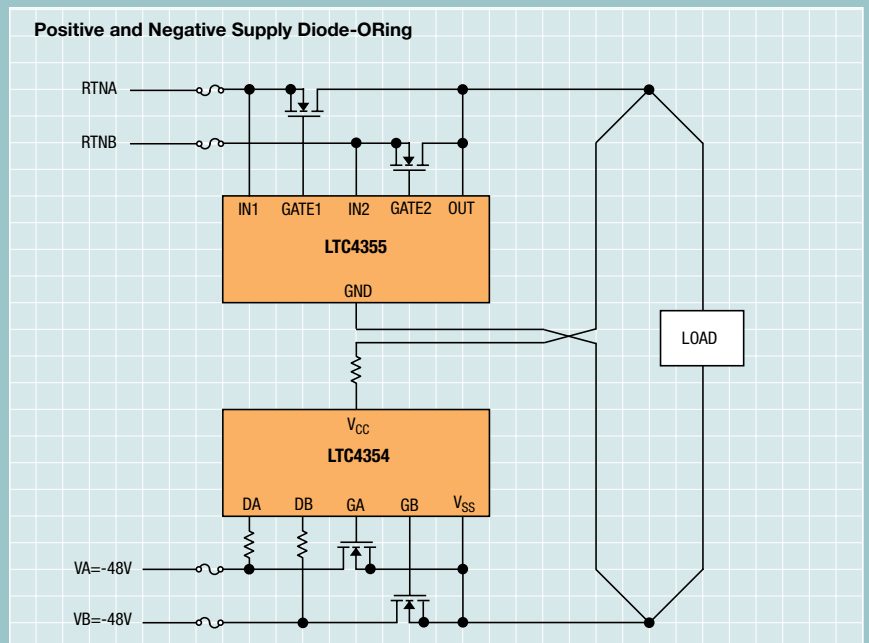
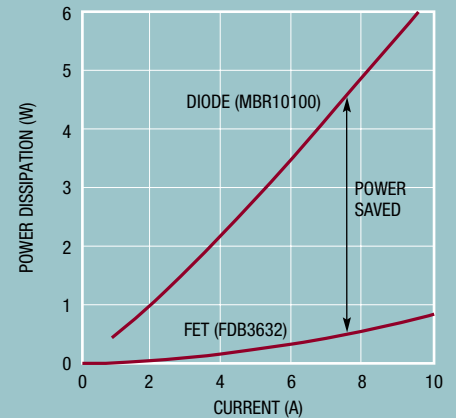

LTC4357: Positive High Voltage Ideal Diode Controller

The LTC4357 easily ORs power sources to increase total system reliability. In diode-OR applications, the LTC4357 controls the forward voltage drop across the MOSFET to ensure smooth current transfer from one path to the other without oscillation. If the power source fails or is shorted, a fast turn-off minimizes reverse current transients.

Features:

- Reduces Power Dissipation by Replacing a Power Schottky Diode with an N-Channel MOSFET
- 0.5µs Turn-Off Time Limits Peak Fault Current
- Wide Operating Voltage Range: 9V to 80V
- Smooth Switchover without Oscillation
- No Reverse DC Current
- Available in 6-Lead (2mm × 3mm) DFN and 8-Lead MSOP Packages

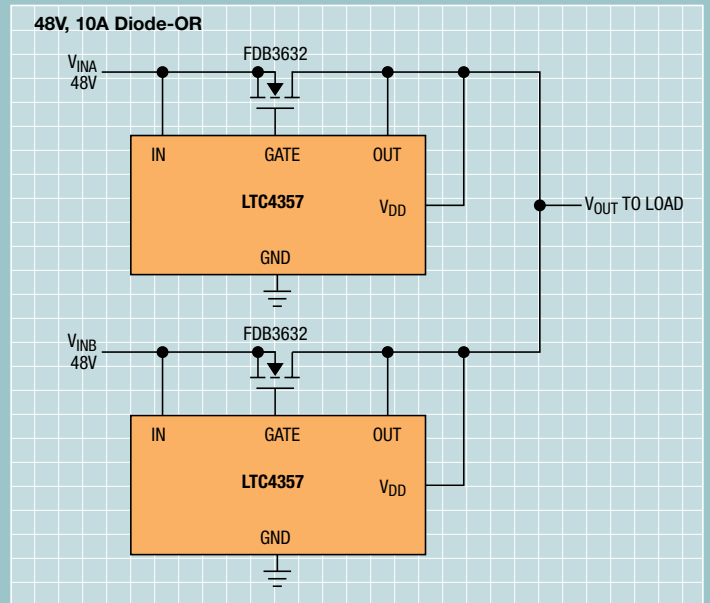

Part Number	Input Supply Range	Ideal Diode	External FET	Fault Monitoring	Package
High Voltage Ideal Diode Controllers					
LTC4354	-4.5V to -100V (Floating)	Dual	N-Channel	Yes	3x2 DFN-8, SO-8
LTC4355	9V to 80V	Dual	N-Channel	Yes	4x3 DFN-14, SO-16, MSOP-16
LTC4357	9V to 80V	Single	N-Channel	No	2x3 DFN-6, MSOP-8

48V Fuse Monitor

The LTC1921 monitors two independent -48V supplies, including their fuses and drives up to three optoisolators to indicate status. Requiring only three noncritical resistors and optoisolators, the LTC1921 replaces multiple voltage comparators, a voltage reference and several precision resistors.

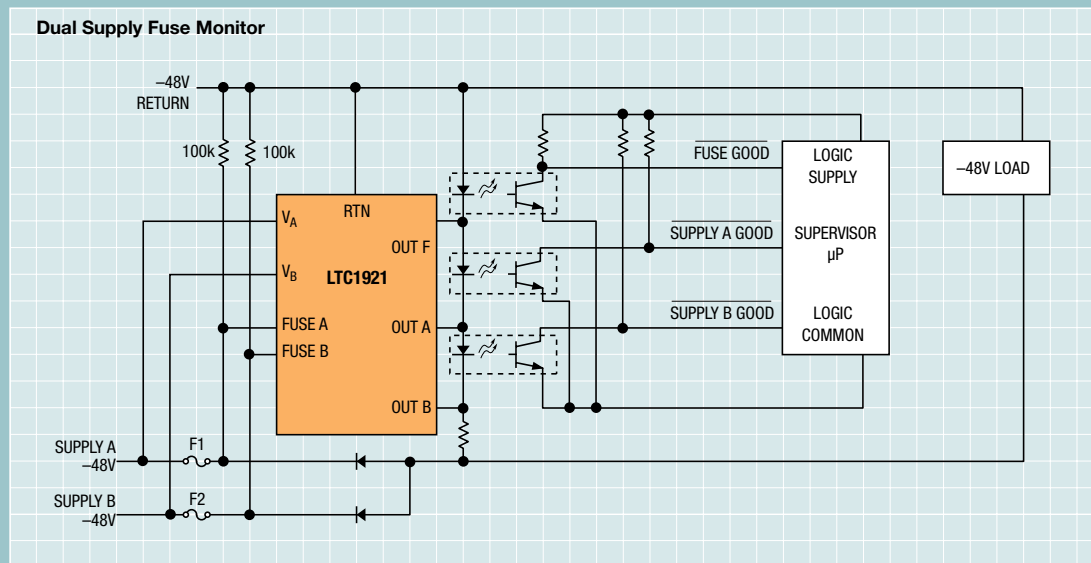

Part Number	Input Voltage Range	UV	OV	Package
Fuse Monitor				
LTC1921	-10V to -80V	Yes	Yes	MSOP-8, SO-8

Ideal Diodes and Controllers – Low Voltage

LTC4352: Low Voltage Ideal Diode Controller with Monitoring

The LTC4352 is a 0V to 18V ideal diode controller that enables low loss ORing of multiple power sources with minimal disturbance to supply voltages. A fast turn-on reduces the load voltage drop during supply switchover. Power passage is disabled during undervoltage or overvoltage conditions. The controller also features an open MOSFET detect circuit that flags excessive voltage drop across the pass transistor in the on state. A REV pin enables reverse current, overriding the diode behavior when desired.

Features:

- Low Loss Replacement for Power Diode
- Controls N-Channel MOSFET
- 0V to 18V Supply ORing or Holdup
- 0.5µs Turn-On and Turn-Off Time
- Undervoltage and Overvoltage Protection
- Open MOSFET Detect
- Status and Fault Outputs
- Hot Swappable
- Reverse Current Enable Input
- 12-Pin MSOP and DFN (3mm × 3mm) Packages

LTC4358: 5A Ideal Diode

The LTC4358 is a 5A ideal diode that uses an internal 20mΩ N-channel MOSFET to replace a Schottky diode when used in diode-OR and high current diode applications. The LTC4358 reduces power consumption, heat dissipation, and PC board area.

Features:

- Replaces a Power Schottky Diode
- Internal 20mΩ N-Channel MOSFET
- 0.5µs Turn-Off Time Limits Peak Fault Current
- Operating Voltage Range: 9V to 26.5V
- Smooth Switchover without Oscillation
- No Reverse DC Current
- Available in 14-Pin (4mm × 3mm) DFN and 16-Lead TSSOP Packages

Part Number	Input Supply Range	Ideal Diode	External FET	Package
5A Ideal Diode				
LTC4352	0V to 18V	Single, Fast Turn-On and Turn-Off	N-Channel	3x4 DFN-12 MSOP-12
LTC4358	9V to 28V	Single	Internal 5A FET	4x3 DFN-14 TSSOP-16
LTC4412	2.5V to 28V	Single	P-Channel	ThinSOT™
LTC4412HV	2.5V to 36V	Single	P-Channel	ThinSOT
LTC4414	3V to 36V	Single	P-Channel	MSOP-8

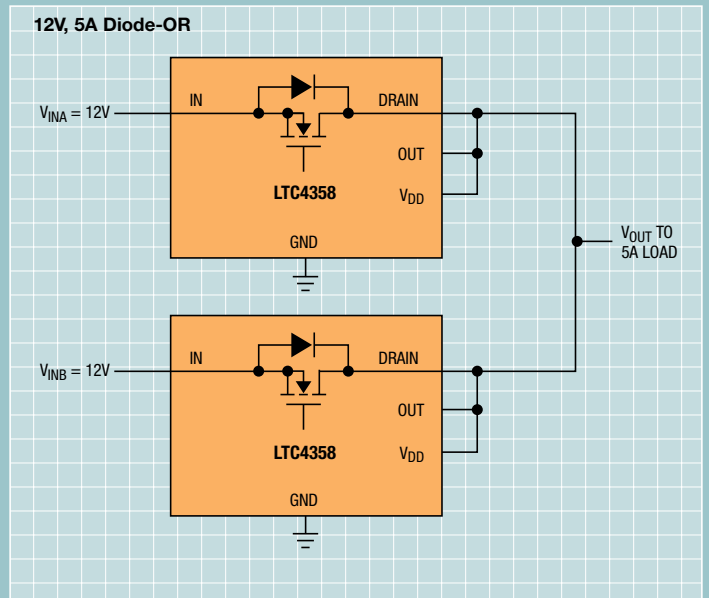
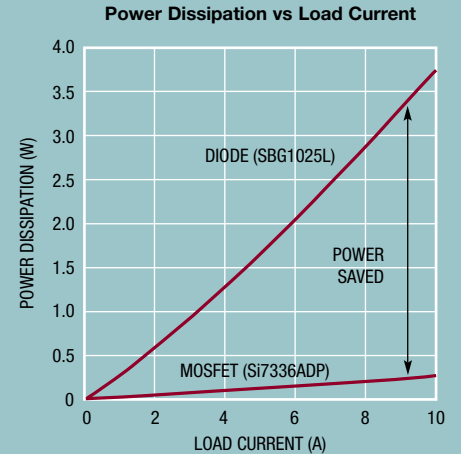
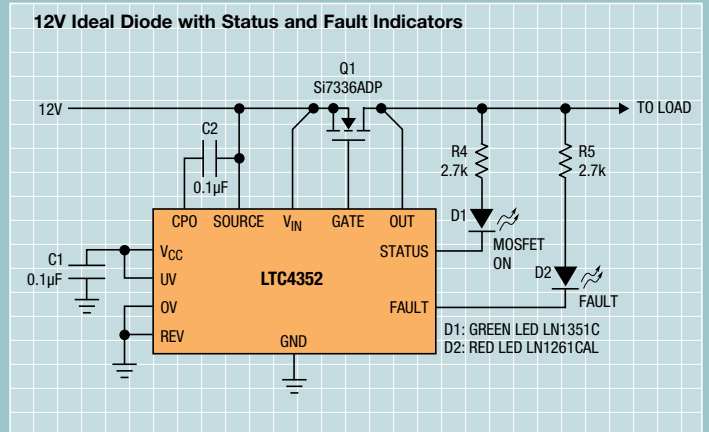

Introduction to DC/DC Controllers

High density power systems require very high efficiency, excellent power density and ease of implementation. Linear Technology offers a family of high performance DC/DC controllers specifically tailored for isolated power conversion for input voltages ranging from 4V to 100V for telecom, datacom and industrial applications. We feature primary- and secondary-side control ICs, which provide synchronous rectification, fast transient response, overvoltage and overcurrent protection and a host of other features. These devices enable output voltages from 0.6V to 52V from flyback, forward, half-bridge, push-pull or full-bridge topologies. Off-the-shelf planar magnetics can be used in many applications, reducing design complexity.

Flyback Controllers – Low Power (Up to 60W)

Synchronous and non-synchronous flyback controllers are offered for output power levels up to 60W. This family of current mode flyback controllers can either regulate the output voltage with integrated primary-side regulation circuitry or can be used with a secondary-side optocoupler driver and optoisolator. Synchronous rectification is easily controlled by the LT3825 or LT3837, which increases conversion efficiency and improves output cross regulation in multiple output power supplies. As an example, the LT3825 can convert an input supply of 36V-75V to an isolated output of 3.3V at 12A with up to 90% efficiency.

Isolated Synchronous Rectified No-Opto Flyback Converter

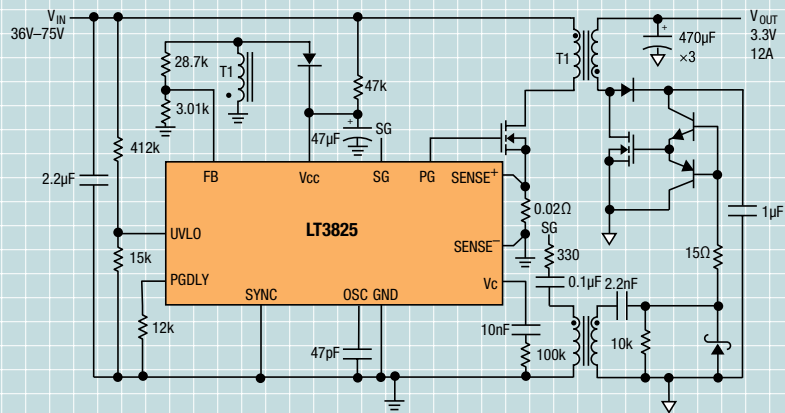

LTC3803-3 Isolated Demo Board

Part Number: DC1100A

V_{IN} : 18V to 75V

Output: 3.3V at 3A



Low Power Isolated Flyback Converter

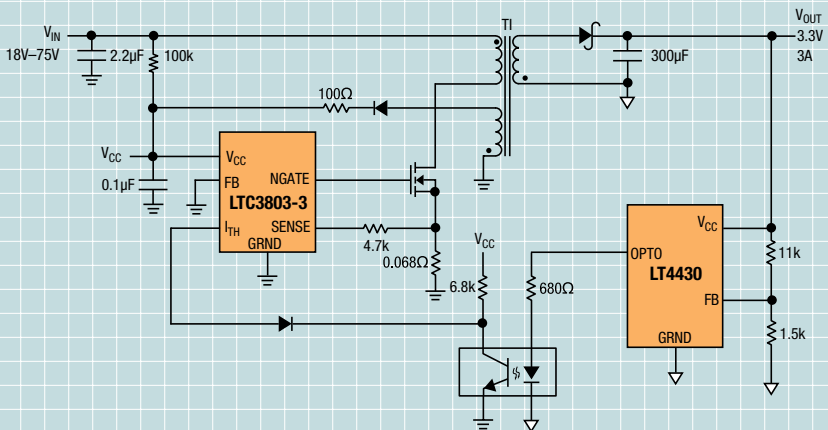

Flyback Controllers/Monolithic – Low Power (Up to 60W)

Part Number	Maximum Output ¹ Power (W)	V _{IN} Range (V)	V _{OUT} ³ Range (V)	Operating Frequency	Package	Description
Primary-Side Flyback Controllers/Monolithic						
LTC3573	7	3 to 40	1.23 to 52	40kHz to 1MHz	MSOP-16E 3x3 QFN-16	No-Opto Flyback with Integrated Power Switch
LTC3803-5	25	4.8 to 75 ³	0.8 to 52	200kHz	ThinSOT	Constant Frequency Current Mode Flyback Controller with 5.7V UVLO
LTC3803-3	25	8.7 to 75 ³	0.8 to 52	200kHz or 300kHz	ThinSOT	Constant Frequency Current Mode Flyback Controller in ThinSOT
LTC3805-5	25	8.4/4.5 to 75 ³	0.8 to 52	70kHz to 700kHz ²	3x3 DFN-10 MSOP-10E	Selectable Frequency Current Mode
LT1737	25	4.5 to 75 ³	1.23 to 52	50kHz to 250kHz ²	S0-16, SSOP-16	No-Opto Flyback Controller
LTC3873/-5	25	8.4/4.1 to 75 ³	1.20 to 52	200kHz	ThinSOT, DFN-8	Constant Frequency Current Mode Controller
LT1725	50	16 to 75 ³	1.20 to 52	50kHz to 250kHz ²	S0-16, SSOP-16	Flyback with or without Optocoupler
LTC1871	50	2.5 to 36	1.23 to 52	50kHz to 1MHz ²	MSOP-10	Wide Input Range Current Mode Controller
LT3825	60	16 to 75 ³	1.23 to 52	50kHz to 250kHz ²	TSSOP-16E	Synchronous Flyback with or without Optocoupler
LT3837	60	4.5 to 75 ³	1.23 to 52	50kHz to 250kHz ²	TSSOP-16E	Synchronous Flyback with or without Optocoupler
LT3757	60	2.9 to 40	1.60 to 52	100kHz to 1MHz ²	MSOP-10E 3x3 DFN-10	Selectable Frequency Current Mode
LT3758	60	5.5 to 100	1.60 to 52	100kHz to 1MHz ²	MSOP-10E 3x3 DFN-10	High Input Voltage Selectable Frequency Current Mode

¹ The maximum output power depends on the choice of external components.

² The operating frequency can be selected within the range indicated.

³ The input and output voltage range depends on external components. For higher voltages, consult factory.

Forward Controllers – Medium Power (Up to 300W)

Linear Technology’s single switch and 2-switch forward controllers normally operate with primary and secondary-side ICs for control, timing and driving of synchronous MOSFETs. The single switch forward converter schematic below shows the LTC3706 as a secondary-side controller with primary-side LTC3725 smart driver. Efficiencies up to 95% are achieved with this circuit for output voltages ranging from 0.6 to 52V.

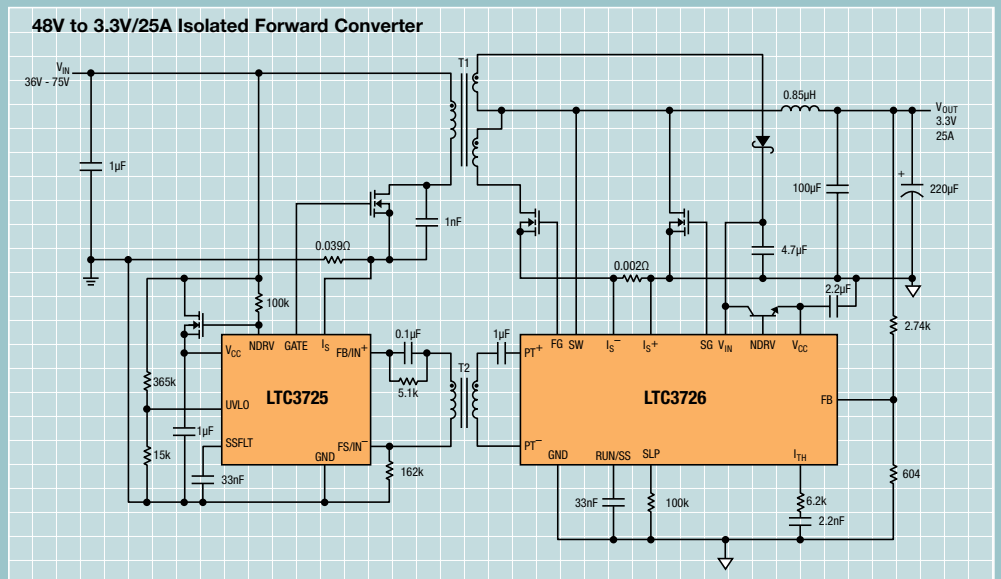
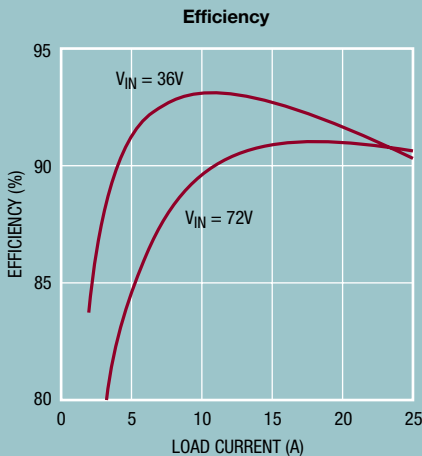

Forward Controllers/Smart Drivers – Medium Power (Up to 300W)

Part Number	MOSFET Drive Current	V_{IN}^3 Range (V)	Operating Frequency ²	Package	Description
Primary-Side Smart Drivers					
LTC3705	2A	9 to 75	70kHz to 700kHz	SSOP-16	2-Switch Forward Smart Gate Driver, Works with Secondary-Side Synchronous Controller LTC3706 or LTC3726
LTC3725	2A	9 to 75	70kHz to 700kHz	MSOP-10E	Single-Switch Forward Smart Gate Driver, Works with Secondary-Side Synchronous Controller LTC3706 or LTC3726

Part Number	Output ¹ Power Range (W)	V_{CC} Range (V)	V_{OUT} Range (V)	Operating Frequency ²	Package	Description
Secondary-Side Controllers						
LTC3706	Up to 300	5 to 30	0.60 to 52	100kHz to 500kHz	SSOP-24	Synchronous Forward Controller with PolyPhase Capability, Can Be Used with Primary Driver LTC3705 or LTC3725
LTC3726	Up to 300	5 to 10	0.60 to 52	100kHz to 500kHz	SSOP-16	Synchronous Forward Controller, Can Be Used with Primary Driver LTC3705 or LTC3725

Part Number	Output ¹ Power Range (W)	V_{IN}^3 Range (V)	V_{OUT} Range (V)	Operating Frequency ²	Package	Description
Primary-Side Controllers						
LT1952/-1	Up to 300	8/15.75 to 75	1.23 to 52	100kHz to 500kHz	SSOP-16	Single-Switch Synchronous Forward Controller, Can Be Used with Secondary-Side LTC3900
LT3781	Up to 300	16 to 75	1.25 to 52	350kHz	SSOP-20	2-Switch Synchronous Forward Controller. Works with LTC1698 MOSFET Driver

Part Number	MOSFET Drive Current	V_{CC} Range (V)	Operating Frequency ²	Package	Description
Secondary-Side Smart Drivers					
LTC3900	2A	4.5 to 11	100kHz to 500kHz	SO-8	Synchronous Rectifier Driver for Forward Converters, Can Be Used with Primary Controller LT1952 or LTC3723
LTC3901	2A	4.5 to 11	100kHz to 500kHz	SSOP-16	Synchronous Rectifier Driver for Push-Pull and Full-Bridge Converters, Can Be Used with Primary Controller LTC3722 or LTC3723
LTC1698	2A	6 to 12.6	350kHz	SSOP-16, SO-16	Synchronous Rectifier Driver for Forward Converters, Can Be Used with Primary Controller LT1952, LTC3723 or LT3781

¹ The maximum output power depends on the choice of external components.

² The operating frequency can be selected within the range indicated.

³ The input voltage range depends on external components. For higher voltages, consult factory.

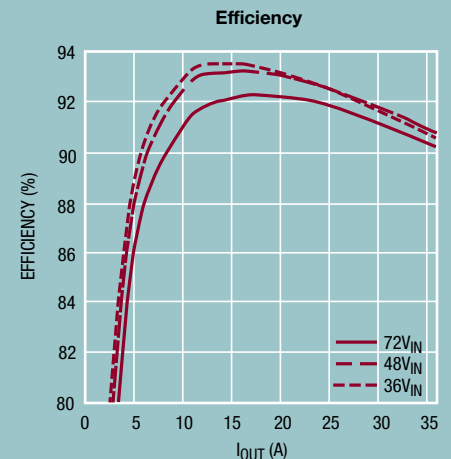
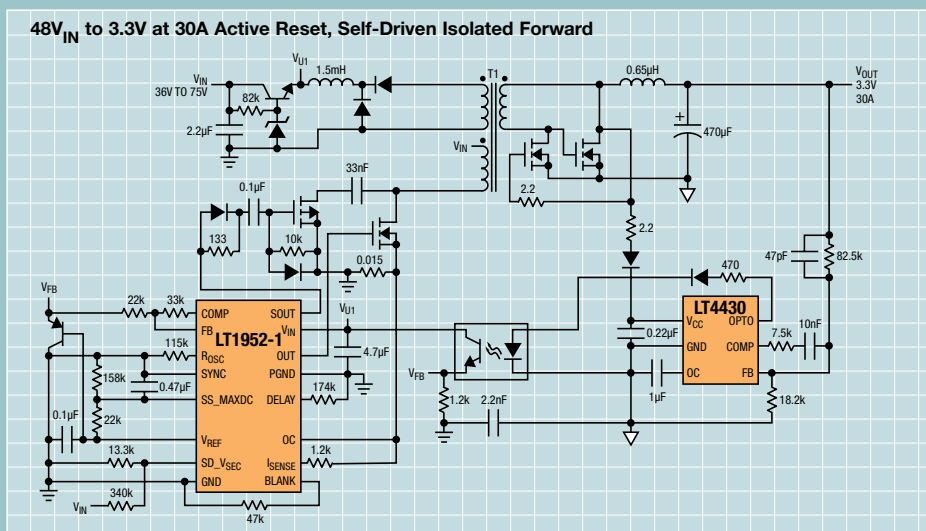

Demonstration Boards – Isolated Solutions for Telecom and Datacom Applications

Linear Technology offers demonstration boards for a wide variety of applications, including isolated and nonisolated power supplies. In addition to the demonstration board, we supply the electrical schematic, bill of materials and Gerber files for the PCB design. We also include a Quick Start Guide that describes the circuit operation and provides performance curves, including load regulation, ripple and noise, efficiency and transient response.

We can also develop customized solutions if the exact demo board for a specific requirement does not exist. Contact your local sales representative for further details.

Below are photos of standard demo boards showing the industry-standard size 1/8 brick, measuring 0.9" x 2.3", and 1/4 brick, measuring 1.45" x 2.3" form factors. Both convert a 36V to 75V input to isolated output voltages ranging from 0.6V to 52V. Efficiencies up to 95% are realized using off-the-shelf planar power transformers and inductors.

1/4 Brick Size Demo Board



1/8 Brick Size Demo Board



Demonstration Board Number	V _{IN} Range (V)	Output Rating(s)	Circuit Size (Inches)	Description
48V Nominal Input Isolated Demonstration Boards				
DC1100A	18 to 75	3.3V/3A	1.63 x 0.56	LTC3803-3 Flyback
DC1311A-A	18 to 75	3.3V/3A	1.50 x 0.63	LTC3805 Flyback
DC1412A	18 to 72	3.3V/3A	1.50 x 0.63	LT3758 Flyback
DC1154A	36 to 75	3.3V/3A	1.50 x 0.63	LTC3873 Flyback
DC649A	36 to 75	5V/2A	1.10 x 1.25	LTC3803 Flyback
DC894A-A	36 to 75	3.3V/12A	1.25 x 1.20	LT3825 Synchronous No-Opto Flyback
DC894A-B	36 to 75	5V/8A	1.25 x 1.20	LT3825 Synchronous No-Opto Flyback
DC894A-C	36 to 75	12V/5A	1.25 x 1.20	LT3825 Synchronous No-Opto Flyback
DC950A-A	36 to 75	5V/2A, 3.3V/3A, 2.5V/3A	1/4 Brick (1.45 x 2.30)	LT3825 Synchronous Flyback Triple Output
DC1031A-A	36 to 75	2.5V/20A	1/8 Brick (0.90 x 2.30)	LTC3725/LTC3726 Synchronous Forward
DC1031A-B	36 to 75	3.3V/20A	1/8 Brick (0.90 x 2.30)	LTC3725/LTC3726 Synchronous Forward
DC968A-A	36 to 75	3.3V/30A	1/8 Brick (0.90 x 2.30)	LT1952-1/LT4430 Synchronous Forward
DC1317A-A ¹	36 to 75	3.3V/30A	1/8 Brick (0.90 x 2.30)	LT1952-1/LT4430 Synchronous Forward
DC759A	36 to 75	5V/20A	1/8 Brick (0.90 x 2.30)	LT1952-1/LT4430 Synchronous Forward
DC1031A-C	36 to 75	5V/20A	1/8 Brick (0.90 x 2.30)	LTC3725/LTC3726 Synchronous Forward
DC1317A-B ¹	18 to 75	5V/25A	1/8 Brick (0.90 x 2.30)	LT1952-1/LT4430 Synchronous Forward
DC968A-C	36 to 75	12V/12A	1/8 Brick (0.90 x 2.30)	LT1952-1/LT4430 Synchronous Forward
DC1032A	36 to 75	12V/12A	1/8 Brick (0.90 x 2.30)	LTC3725/LTC3726 Synchronous Forward
DC1317A-C ¹	18 to 75	12V/10A	1/8 Brick (0.90 x 2.30)	LT1952-1/LT4430 Synchronous Forward
DC1317A-D ¹	18 to 75	24V/5A	1/8 Brick (0.90 x 2.30)	LT1952-1/LT4430 Synchronous Forward
DC968A-D	36 to 75	28V/4A	1/8 Brick (0.90 x 2.30)	LTC3705/LTC3706 Synchronous Forward
DC677A	36 to 75	3.3V/50A	1.70 x 2.90	LT1952/LT4430 Synchronous Forward
DC830A	36 to 75	3.3V/40A	1/4 Brick (1.45 x 2.30)	LT1952/LT4430 Synchronous Forward
DC888A-A ²	36 to 75	3.3V/50A	1/4 Brick (1.45 x 2.30)	LTC3725/LTC3706 Synchronous Forward
DC888A-B ²	36 to 75	5V/40A	1/4 Brick (1.45 x 2.30)	LTC3725/LTC3706 Synchronous Forward
DC888A-C ²	36 to 75	12V/20A	1/4 Brick (1.45 x 2.30)	LTC3725/LTC3706 Synchronous Forward
DC607A	36 to 75	12V/35A	4 X 3	LTC3722-1 Synchronous Full-Bridge

¹ These designs utilize active transformer reset.

² These boards are designed to be paralleled for higher current applications.

Isolated Solutions for Industrial Applications

Many industrial applications demand isolation and high efficiency at lower input voltages. Linear Technology offers multiple controllers specifically designed for isolated power conversion from 12V and 24V sources. Advantages of these solutions include reduced complexity, synchronous rectification and the ability to accommodate other output voltages and power levels with relatively minor changes to existing designs. Leveraging these flyback and forward solutions results in shorter design cycles and flexible designs.



LT3573 Isolated Demo Board

Part Number: DC1228A

V_{IN} : 10V to 30V

Output: 5V at 1A



LTC3725/LTC3726 Isolated Demo Board

Part Number: DC1174A-A

V_{IN} : 9V to 36V

Output: 5V at 10A

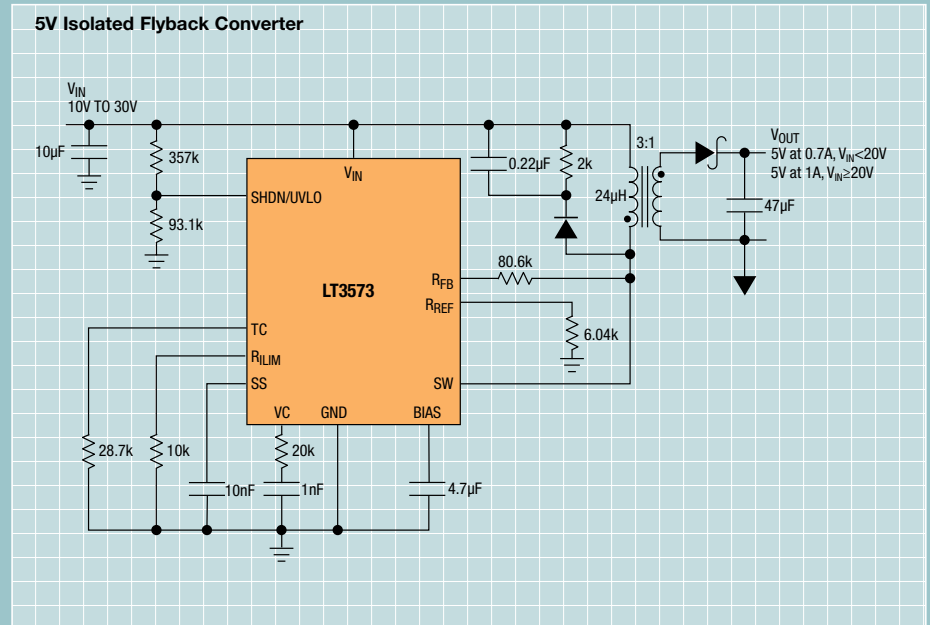

Demonstration Board Number	V_{IN} Range (V)	Output Rating(s)	Circuit Size (Inches)	Description
24V Nominal Input Isolated Flyback and Forward Demonstration Boards				
DC1228A	10 to 30	5V/1A	0.59 x 1.22	LT3573 Monolithic No-Opto Flyback
DC418A	8 to 36	5V/0.2A, $\pm 15V/0.1A$	1.50 x 1.50	LT1737 No-Opto Flyback Triple Output
DC1038A-A	9 to 36	3.3V/10A	1.20 x 1.50	LT3837 Synchronous No-Opto Flyback
DC1038A-B	9 to 36	5V/7A	1.20 x 1.50	LT3837 Synchronous No-Opto Flyback
DC1038A-C	9 to 36	12V/3A	1.20 x 1.50	LT3837 Synchronous No-Opto Flyback
DC950A-B	9 to 36	2.5V/3A, 3.3V/3A, 5V/2A	1/8 Brick (0.90 x 2.30)	LT3837 Synchronous No-Opto Flyback Triple Output
DC1317A-F	9 to 36	3.3V/20A	1/8 Brick (0.90 x 2.30)	LT1952-1/LT4430 Synchronous Forward
DC1174A-A	9 to 36	5V/10A	1/8 Brick (0.90 x 2.30)	LTC3725/LTC3726 Synchronous Forward
DC1174A-B	9 to 36	12V/4A	1/8 Brick (0.90 x 2.30)	LTC3725/LTC3726 Synchronous Forward
DC1317A-G	9 to 36	12V/5A	1/8 Brick (0.90 x 2.30)	LT1952-1/LT4430 Synchronous Forward
DC1174A-C	9 to 36	15V/3.3A	1/8 Brick (0.90 x 2.30)	LTC3725/LTC3726 Synchronous Forward
DC968A-B	18 to 36	5V/20A	1/8 Brick (0.90 x 2.30)	LT1952/LTC3900 Synchronous Forward
DC1317A-H	9 to 36	48V/1.5A	1/8 Brick (0.90 x 2.30)	LT1952-1/LT4430 Synchronous Forward
DC1300A-A	9 to 36	5V/20A	1/4 Brick (1.45 x 2.30)	LTC3725/LTC3726 Synchronous Forward
DC1300A-B	9 to 36	12V/8.4A	1/4 Brick (1.45 x 2.30)	LTC3725/LTC3726 Synchronous Forward
DC1300A-C	9 to 36	15V/6.7A	1/4 Brick (1.45 x 2.30)	LTC3725/LTC3726 Synchronous Forward

Push-Pull, Half- and Full-Bridge Controllers – High Power (100W to 750W)

The LTC3721 and LTC3723 controllers are well suited for power levels from 100W to 750W, providing simple solutions for high power applications. Synchronous and non-synchronous rectification modes of operation are supported. The push-pull, half- and full-bridge configurations offer smaller input filter and output inductors compared to single-ended converters. They also provide up to 40% greater transformer utilization and balanced semiconductor power dissipation over the input voltage range.

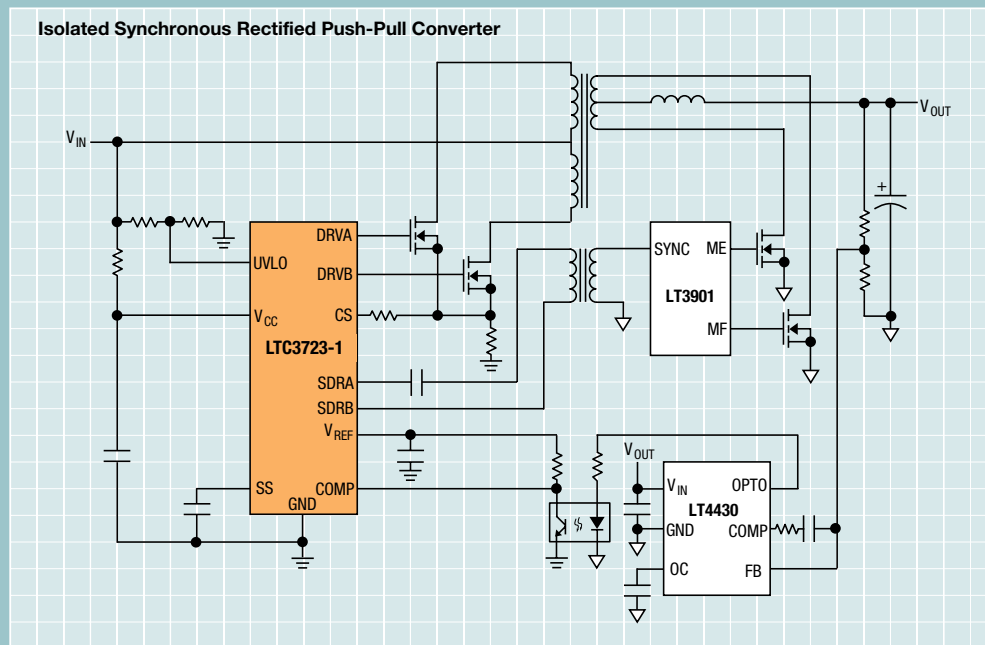
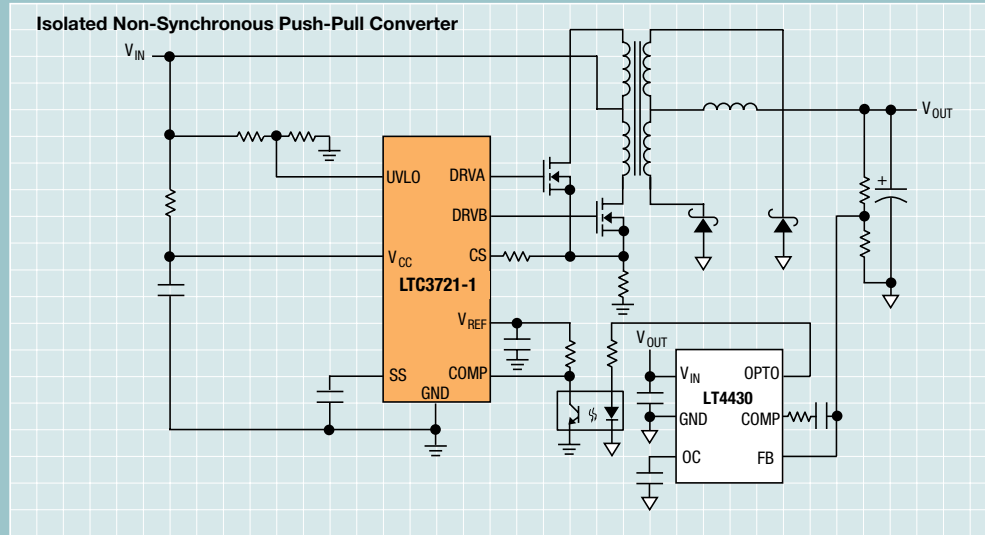

Part Number	Output ¹ Power Range (W)	V _{IN} ³ Range (V)	V _{OUT} Range (V)	Operating Frequency ²	Package	Description
Primary-Side Push-Pull, Half-Bridge and Full-Bridge Controllers						
LTC3721-1	100 to 750	10.7 to 75	1.2 to 52	Up to 1MHz	SSOP-16 4x4 QFN-16	Push-Pull and Full-Bridge Non-Synchronous Topologies
LTC3723-1	100 to 750	10.7 to 75	1.2 to 52	Up to 1MHz	SSOP-16	Push-Pull and Full-Bridge Current Mode Synchronous Topologies
LTC3723-2	100 to 750	10.7 to 75	1.2 to 52	Up to 1MHz	SSOP-16	Push-Pull, Half-Bridge and Full-Bridge Voltage Mode Synchronous Topologies

¹ The maximum output power depends on the choice of external components.
² The operating frequency can be selected within the range indicated.
³ The input voltage range depends on external components. For higher voltages, consult factory.

Full-Bridge Phase-Modulated Controllers – Higher Power (200W to 1KW)

The phase-modulated full-bridge LTC3722 controller employs zero voltage switching (ZVS) with phase-shifted power supply control, intended for isolated offline and distributed power supplies of 200W to 1 kilowatt. This device operates at a selectable fixed frequency with current mode control and adaptive zero voltage delay control over all operating conditions, optimizing efficiency and reducing transformer size and EMI. This controller also provides simple programmability for current limit, leading edge blanking, soft-start and short-circuit protection.

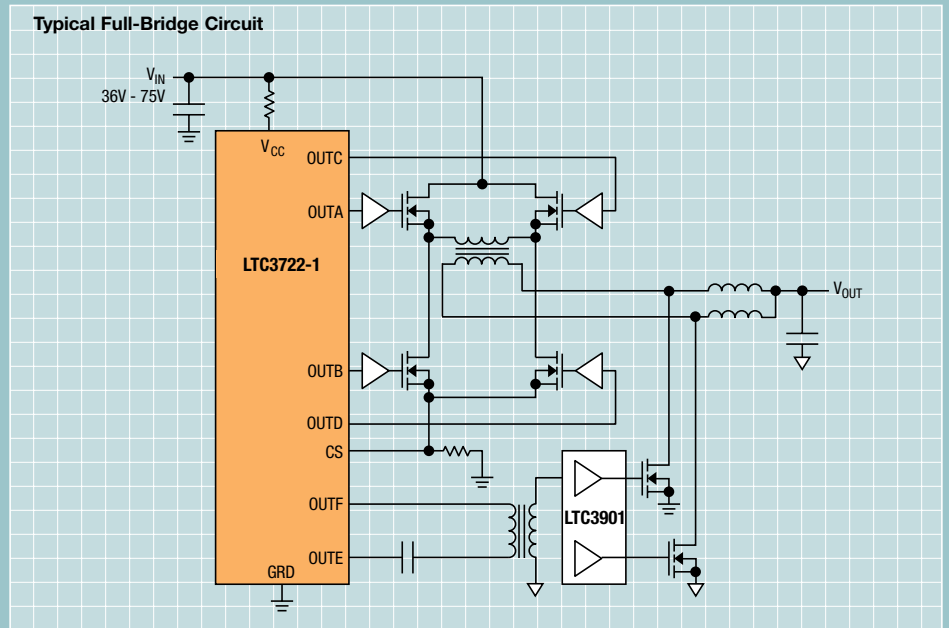

Part Number	Output ¹ Power Range (W)	V_{IN} ³ Range (V)	V_{OUT} Range (V)	Operating Frequency ²	Package	Description
Primary-Side Full-Bridge Controllers						
LTC3722-1	200 to 1K	10.5 to 75	5 to 24	300kHz to 1MHz	SSOP-24	Full-Bridge Synchronous with ZVS, Current Mode Control
LTC3722-2	200 to 1K	10.5 to 75	5 to 24	300kHz to 1MHz	SSOP-24	Full-Bridge Synchronous with ZVS, Voltage Mode Control

¹ The maximum output power depends on the choice of external components.
² The operating frequency can be selected within the range indicated.
³ The input voltage range depends on external components. For higher voltages, consult factory.

LTC3722-1 Isolated Demo Board

Part Number: DC607A
 V_{IN} : 36V to 75V, Output: 12V at 35A



Introduction

Linear Technology offers controllers, monolithic switching regulators and linear regulators for high voltage (up to 100V) nonisolated step-down (buck) and step-up (boost) DC/DC power conversion. Topologies include synchronous and non-synchronous buck, boost, buck-boost, forward and flyback converters. Included are low quiescent current controllers and monolithic parts that help preserve battery life during standby mode.

Buck and Boost Controllers – High Voltage

Shown below are synchronous and non-synchronous buck and boost controllers that operate from input voltages up to 100 volts. Selection parameters include output voltage range, operating frequency, quiescent current and choice of sense resistor.

LTC3810 Demo Board

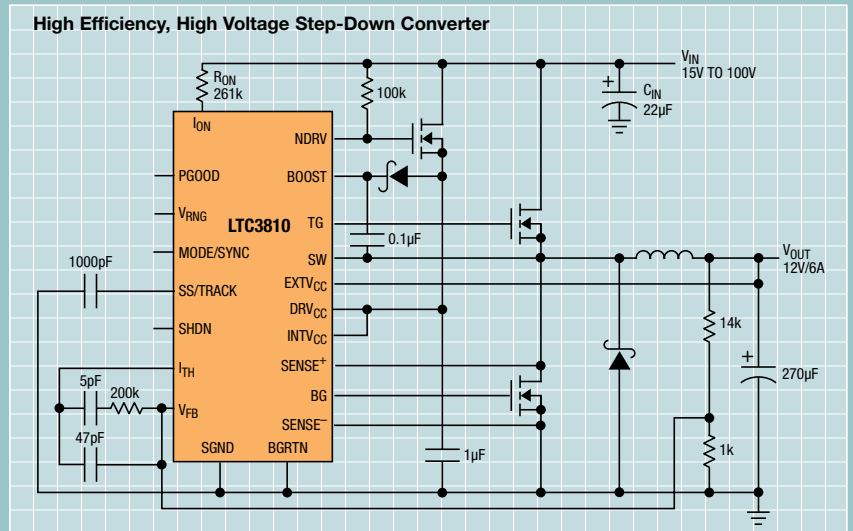
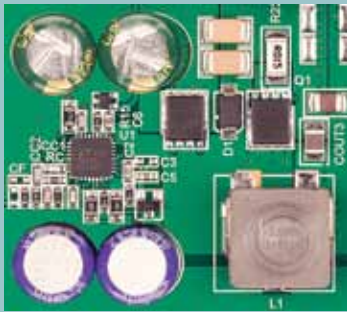

Part Number	V_{IN} Range (V)	V_{OUT} Range (V)	Max Output Current (A) ¹	Synchronous Operation	Operating Frequency ²	No Sense Resistor	Package
Buck Controllers							
LT3724	4 to 60	1.23 to 36	5		200kHz		TSSOP-16E
LTC3824	4 to 60	0.8 to V_{IN}	5		200kHz to 600kHz		MSOP-10E
LTC3703-5	4.1 to 60	0.8 to $0.93V_{IN}$	10	X	100kHz to 600kHz	X	SSOP-16, SSOP-28
LTC3703	9.3 to 100	0.8 to $0.93V_{IN}$	10	X	100kHz to 600kHz	X	SSOP-16, SSOP-28
LT3844	4 to 60	1.23 to 36	10		100kHz to 600kHz		TSSOP-16E
LT3800	4 to 60	1.23 to 36	20	X	200kHz		TSSOP-16E
LTC3812-5	4.2 to 60	0.8 to $0.93V_{IN}$	20	X	100kHz to 1MHz Constant On-Time	X	TSSOP-16E
LT3845	4 to 60	1.23 to 36	20	X	100kHz to 600kHz		TSSOP-16E
LTC3810	6.2 to 100	0.8 to $0.93V_{IN}$	20	X	100kHz to 1MHz Constant On-Time	X	SSOP-28
LTC3810-5	4.2 to 60	0.8 to $0.93V_{IN}$	20	X	100kHz to 1MHz Constant On-Time	X	5x5 QFN-32
Boost Controllers							
LTC1871/-1/-7	2.5 to 36	8 and Higher ³	5		50kHz to 1MHz	X	MSOP-10
LT3757	2.9 to 40	8 and Higher ³	5		100kHz to 1MHz		3x3 DFN-10, MSOP-10E
LT3758	5.5 to 100	8 and Higher ³	5		100kHz to 1MHz		3x3 DFN-10, MSOP-10E
LTC3814-5	4.5 to $0.9V_{OUT}$	8 to 60	10	X	100kHz to 1MHz	X	TSSOP-16
LTC3813	7 to $0.9V_{OUT}$	8 to 100	10	X	100kHz to 1MHz	X	SSOP-28
LT3782A	6 to 40	8 and Higher ³	20		150kHz to 500kHz		SSOP-28, 4x5 QFN-28
LTC3862/-1	4/8.5V to 36	8 and Higher ³	40		75kHz to 500kHz		TSSOP-24, SSOP-24, 5x5 QFN-24

¹The maximum output current depends on the choice of external components.

²The frequency can be selected within the range indicated.

³The output voltage depends upon external components.

Forward Controllers

The forward converter is the preferred topology for very high step-down ratio nonisolated applications. This topology produces a higher efficiency converter when stepping down from 48V to voltages below 5V versus a conventional buck and allows the use of smaller input and output capacitors.

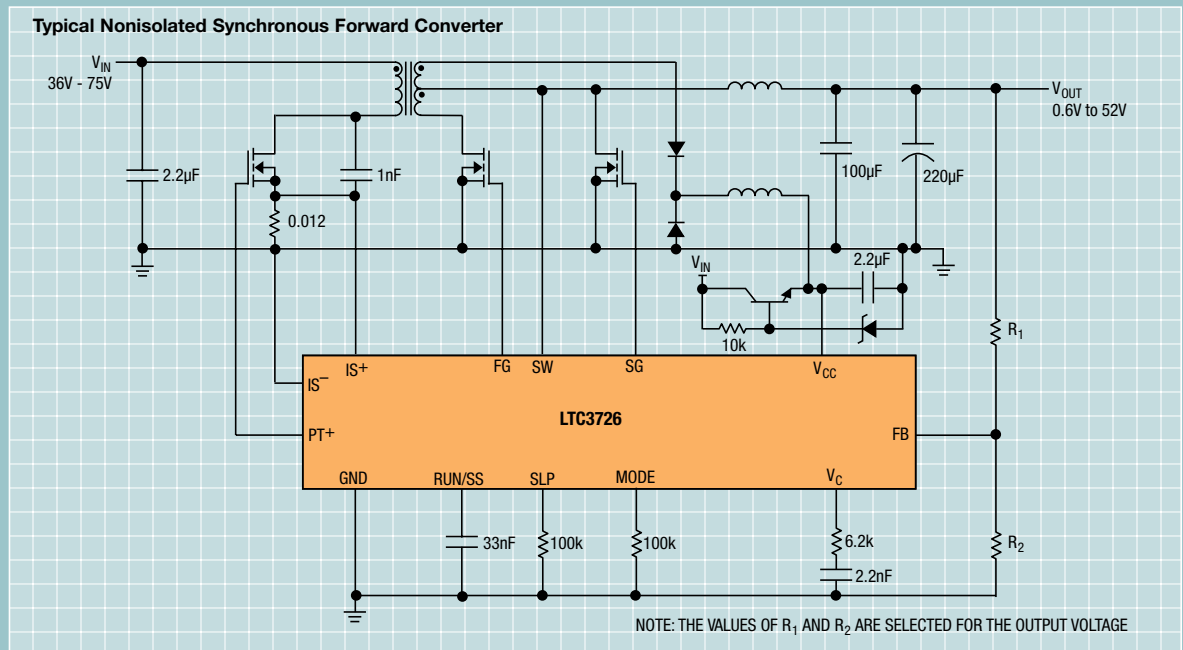
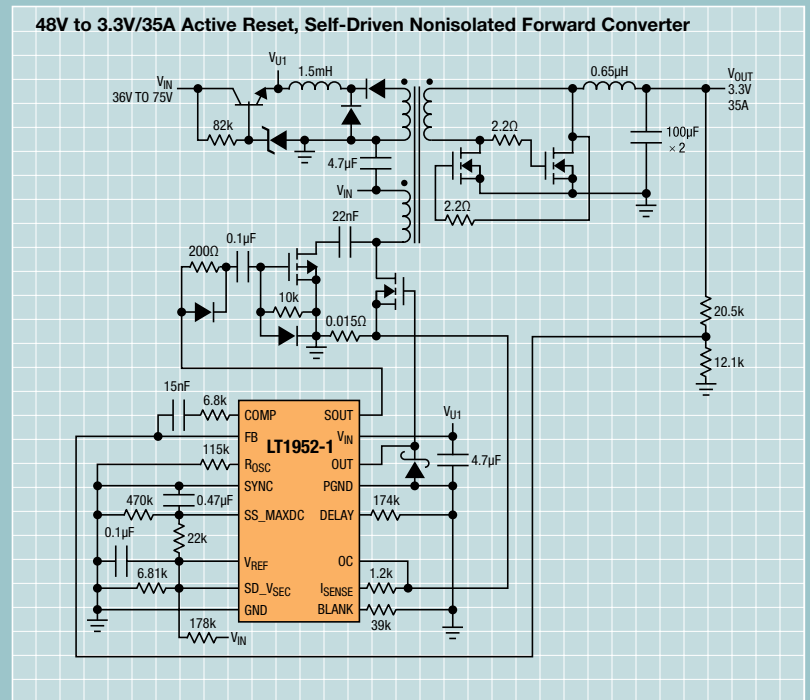

Part Number	V_{IN} Range (V) ⁴	V_{OUT} Range (V)	Max Output Current (A) ¹	Synchronous Operation	Operating Frequency ²	I_o (SUPPLY)	Package
Forward Controllers							
LT1952	15.75 to 75	1.23 to 52	40		100kHz to 500kHz	5.2mA	SSOP-16
LT1952-1	8 to 75	1.23 to 52	40		100kHz to 500kHz	5.2mA	SSOP-16
LTC3706 ³	5 to 75	0.6 to 52	50	x	70kHz to 500kHz	4.2mA	SSOP-24
LTC3726 ³	5 to 75	0.6 to 52	50	x	70kHz to 500kHz	4.2mA	SSOP-16

¹ The maximum output current depends on the choice of external components.

² The frequency can be selected within the range indicated.

³ These ICs can be used in paralleled converters for higher current applications.

⁴ For higher input voltages, consult factory.

Synchronous Buck-Boost

Linear offers high performance synchronous buck-boost μ Module regulators and controllers that operate from input voltages that can be above, below or equal to the output voltage. These devices utilize a single inductor and can deliver efficiencies up to 98%.



LTM[®]4609: Demo Board
Part Number: DC1477A

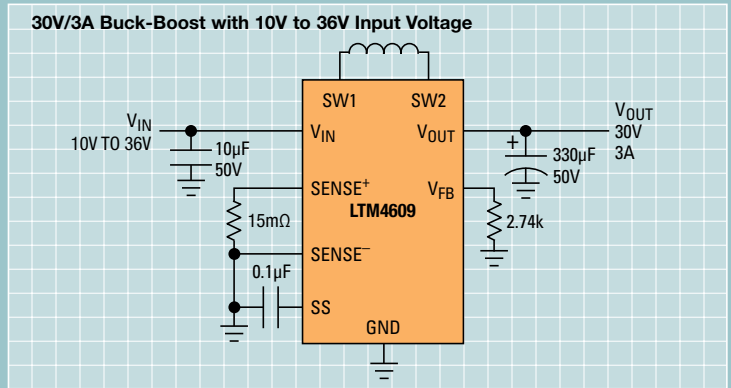

Part Number	V _{IN} Range (V)	V _{OUT} Range (V)	Max Output Current (A) ¹	Frequency (kHz)	Package
Buck-Boost μModule Regulators					
LTM4605	4.5 to 20	0.8 to 16	5 (12 in Buck Mode)	200 to 400	15x15 LGA
LTM4607	4.5 to 36	0.8 to 24	5 (10 in Buck Mode)	200 to 400	15x15 LGA
LTM4609	4.5 to 36	0.8 to 34	4 (10 in Buck Mode)	200 to 400	15x15 LGA

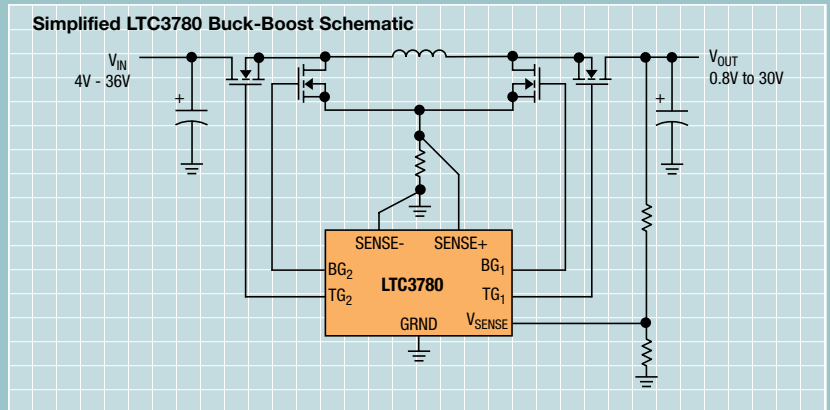
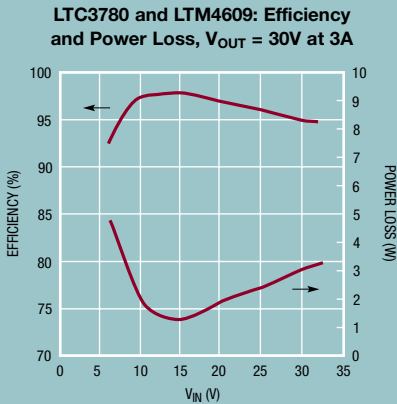

Part Number	V _{IN} Range (V)	V _{OUT} Range (V)	Max Output Current (A) ¹	Frequency (kHz)	Package
Buck-Boost Controllers					
LTC3780 ²	4 to 36	0.8 to 30	15	200 to 400	5x5 QFN-32, SSOP-24
LTC3785 ²	2.7 to 10	2.7 to 10	10	100 to 1MHz	4x4 QFN-24

Part Number	V _{IN} Range (V)	V _{OUT} Ratings	Circuit Size (Inches)	Description
Buck-Boost Demonstration Boards				
DC1198A-A	4.5 to 20	12V/5A	1.50 x 0.875	LTM4605 Buck-Boost
DC1198A-B	6 to 36	12V/5A	1.50 x 0.875	LTM4607 Buck-Boost
DC1477A	10 to 36	30V/3A	1.50 x 0.875	LTM4609 Buck-Boost
DC686A	5 to 32	12V/5A	1.50 x 1.50	LTC3780 Buck-Boost
DC1163A	6 to 32	12V/12A	2.0 x 2.50	LTC3780 Buck-Boost
DC1046A	36 to 72	48V/6A	2.0 x 2.0	LTC3780/LTC4440 Buck-Boost
DC957	2.7 to 10	3.3V/3A	0.50 x 0.75	LTC3785 Buck-Boost

¹ Depends on external components. For higher current, consult factory.

² The input and output voltage can be extended by using external MOSFET drivers, like the LTC4440 and LTC4444.

Monolithic Buck Regulators – High Voltage

Monolithic buck regulators include the switching MOSFET or transistor, and the current sense resistor inside the device to simplify the circuit design. Shown below is a list of synchronous and non-synchronous parts used for up to 80V step-down regulation.

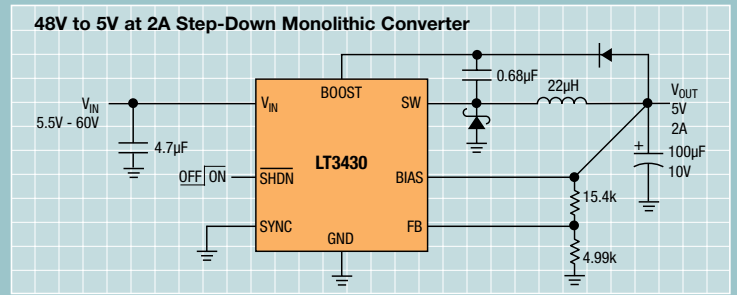

Part Number	V _{IN} Range (V)	V _{OUT} Range (V)	Max Output Current (A)	Operating Frequency (kHz)	Synchronous	Package
Monolithic Buck Regulators – High Voltage						
LTC3632	4.5 to 50, 60pk	0.8 to V _{IN}	0.02	50 to 580	X	3x3 DFN-8, MSOP-8E
LTC3642	4.5 to 45, 60pk	0.8 to V _{IN}	0.05	50 to 580	X	3x3 DFN-8, MSOP-8E
LTC3631	4.5 to 45, 60pk	0.8 to V _{IN}	0.10	50 to 580	X	3x3 DFN-8, MSOP-8E
LT3990	4 to 60	1.12 to 30	0.35	250 to 2MHz		2x3 DFN-10, MSOP-10
LT3437	3.3 to 60, 80pk	1.25 to 0.90V _{IN}	0.40	200		TSSOP-16E, 3x3 DFN-10
LT1676	7.4 to 60	1.25 to 0.90V _{IN}	0.44	100		SO-8
LT3991	4 to 60	1.12 to 30	1.2	200 to 2MHz		3x3 DFN-10, MSOP-10E
LT1976/B	3.3 to 60	1.25 to 0.90V _{IN}	1.20	200		TSSOP-16E
LT1766	5.5 to 60	1.2 to 0.90V _{IN}	1.20	200		TSSOP-16E
LT3980	3.6 to 58, 80pk	0.79 to 30	2.2	250 to 2MHz		3x4 DFN-14, MSOP-16E
LT3434	3.3 to 60	1.25 to 0.90V _{IN}	2.75	200		TSSOP-16E
LT3430/-1	5.5 to 60	1.22 to 0.90V _{IN}	2.75	200/100		TSSOP-16E
LT1074HV	8 to 60	2.21 to 0.85V _{IN}	5.0	100		5-Lead TO-220, 7-Lead DD

High Voltage Linear Regulators

Linear Technology offers several very robust, high voltage LDO regulators with an 80V or higher input voltage rating. All devices are offered in a very compact and thermally efficient footprint, ensuring the highest reliability.

Part Number	Max Output Current (mA)	Min V _{IN} (V)	Max V _{IN} (V)	Dropout Voltage (V at I _{OUT})	I _Q (Supply)	Shutdown Current	V _{OUT} Range (V)	Max Junction Temp (°C)	Package
High Voltage Linear Regulators									
LT3014/HV	20	3.0	80/100pk	0.35	7µA	<1µA	1.22 to 60	125	ThinSOT, DFN-8
LT3014B/HV	20	3.0	80/100pk	0.35	7µA	n/a	1.22 to 60	125	ThinSOT, DFN-8
LT3010/-5	50	3.0	80	0.30	30µA	<1µA	1.275 to 60	125	MSOP-8E
LT3010H	50	4.0	80	0.40	30µA	<1µA	1.275 to 60	140	MSOP-8E
LT3011	50	3.0	80	0.30	46µA	<1µA	1.24 to 60	125	MSOP-12E, DFN-10
LT3011H	50	3.0	80	0.30	46µA	<1µA	1.24 to 60	150	MSOP-12E
LT3012	250	4.0	80	0.40	40µA	<1µA	1.24 to 60	125	TSSOP-16E, DFN-12
LT3012B	250	4.0	80	0.40	40µA	n/a	1.24 to 60	125	TSSOP-16E, DFN-12
LT3012H	200	4.0	80	0.40	40µA	<1µA	1.24 to 60	140	TSSOP-16E
LT3013	250	4.0	80	0.40	65µA	<1µA	1.24 to 60	125	TSSOP-16E, DFN-12
LT3013B	250	4.0	80	0.40	65µA	n/a	1.24 to 60	125	TSSOP-16E, DFN-12
LT3013H	200	4.0	80	0.40	65µA	<1µA	1.24 to 60	140	TSSOP-16E
LT3013MP ¹	250	4.0	80	0.40	65µA	<1µA	1.24 to 60	125	TSSOP-16E

¹ T_{junction} = -55°C to 125°C

High Speed MOSFET Drivers

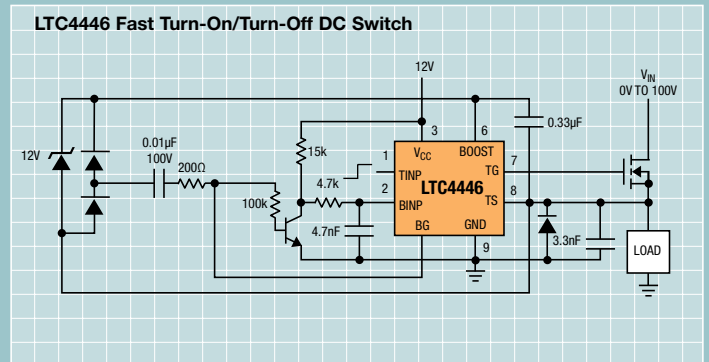
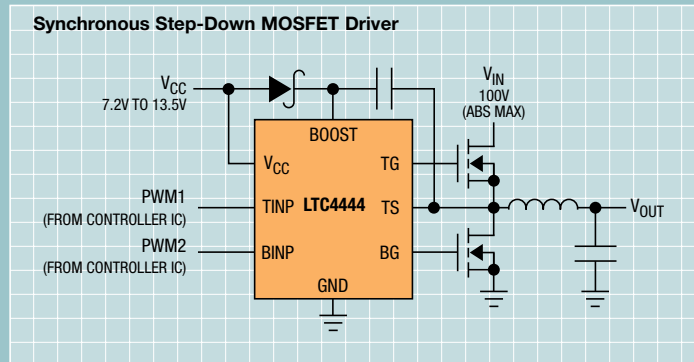

Part Number	V _{CC} Input Voltage Range (V)	Maximum V _{IN} Supply Voltage (V)	Maximum Output Current/Impedance Source/Sink	I _Q (µA)	Package	Description
High Speed MOSFET Drivers						
LTC1693-1	4.5 to 13.2	14	1.4A/1.7A	730	SO-8	Dual N-Channel Both Non-Inverting
LTC1693-2	4.5 to 13.2	14	1.4A/1.7A	730	SO-8	Dual N-Channel 1 Non-Inverting, 1 Inverting
LTC1693-3	4.5 to 13.2	14	1.4A/1.7A	730	MSOP-8	Single with Output Polarity Select
LTC1693-5	4.5 to 13.2	14	1.4A/1.7A	360	MSOP-8	Single P-Channel Driver
LTC4441/-1	5 to 8	28	6A/6A	250	MSOP-10E, SO-8	Low Side Driver
LTC4440	7.3 to 15	80, 100pk	2.4A/1.5Ω	250	MSOP-8E, TSOT-23	High Side, High Voltage
LTC4440-5	4 to 15	60, 80pk	1.1A/1.85Ω	200	MSOP-8E, TSOT-23	High Side, High Voltage
LTC3900	4.5 to 11	12	2A/2A	500	SO-8	Synchronous Driver for Forward Converters
LTC3901	4.5 to 11	12	2A/2A	500	SSOP-16	Synchronous Driver for Push-Pull and Full-Bridge Converters
LTC4442/-1	6.2 to 9.5	38	2.4A/5A	730	MSOP-8E	Synchronous Driver
LTC4444	7.2 to 13.5	100	2.5A/2.5A	350	MSOP-8E	Synchronous High Voltage Driver
LTC4446	7.2 to 13.5	100	2.5A/3A	350	MSOP-8E	High Side/Low Side Driver, Full-Bridge and DC Switch Applications
LTC4444-5	4.5 to 13.5	100	1.4A/1.75A	320	MSOP-8E	Synchronous High Voltage Driver with Lower V _{CC} Voltage

Optocoupler Driver/Reference Voltage

The LT4430 drives optoisolators that cross the isolation barrier in an isolated power supply. The IC contains a precision-trimmed reference and a high bandwidth error amplifier. The LT1431 is an adjustable shunt voltage regulator with 100mA sink capability and $\pm 0.2\%$ initial reference voltage accuracy.

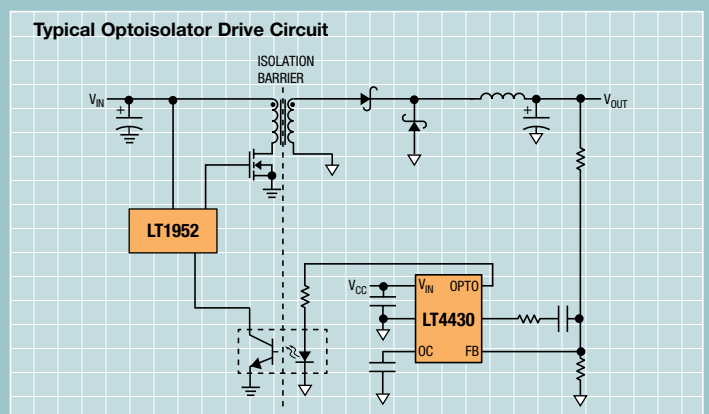

Part Number	Driver Current Limit (mA)	Initial Accuracy	Tolerance Over Temp Range	Reference Voltage (V)	Package
Optocoupler Driver/Reference Voltage					
LT4430	10	$\pm 0.75\%$	$\pm 1.25\%$ (-40°C to 125°C)	0.6	ThinSOT™
LT1431	100	$\pm 0.2\%$	$\pm 1.4\%$ (-40°C to 85°C)	2.5	S-8/N-8/TO-92

Power over Ethernet Controllers

Building on industry-leading Hot Swap technology, Linear Technology offers cost effective solutions for delivering Power over Ethernet (PoE), including controllers for Power Sourcing Equipment (PSE) and Powered Devices (PD).

Linear Technology offers both single and multiport PSE controllers to satisfy any PoE requirement. The LTC4263-1 is an autonomous single-channel PSE controller for use in IEEE 802.3af compliant PoE systems. It includes an onboard power MOSFET, inrush current limit and short-circuit control, and PD detection and classification circuitry. Onboard control algorithms provide complete IEEE 802.3af compliant operation without the need for a microcontroller. The

LTC4263-1 simplifies PSE implementation, requiring only a single 48V supply and a few passive support components.

The LTC4266 quad, high power PSE controller meets the requirements of the new IEEE 802.3at (PoE+) specification and includes advanced features such as true 14-bit port current and voltage readback, programmable power levels for enforcing classification, and industry-leading power efficiency.

Linear Technology offers a wide array of solutions for PD applications, including the new, high power LTC4269 PD with integrated switcher family. The LTC4269 family offers IEEE 802.3at compatibility, flexible auxiliary power options and switcher efficiencies as high as 96%.

LTC4269-1/-2: IEEE 802.3at PD Controllers with Integrated Switchers

Features:

- 25.5W IEEE 802.3at Compliant (Type-2) PD
- IEEE 802.3at High Power Available Indicator
- Integrated Synchronous No-Opto Flyback Controller or Synchronous Forward Controller
- Superior EMI Performance
- Programmable Soft-Start and Switching Frequency
- Flexible Integrated Auxiliary Power Support
- Robust 100V Integrated Hot Swap MOSFET
- Undervoltage, Overvoltage and Thermal Protection
- Available in Compact 32-Pin 7mm x 4mm DFN Package

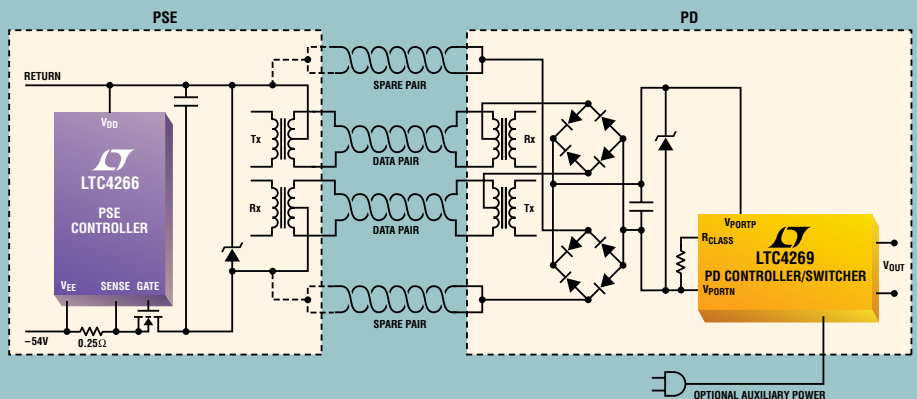
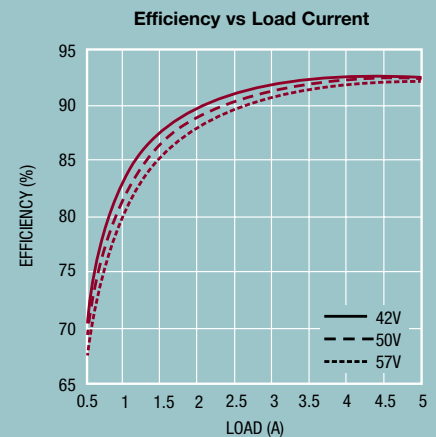

Part Number	PSE/PD	Channels	Description	IEEE-Compliant Detection	IEEE-Compliant Disconnection	Package
High Power PoE Products						
LTC4264	PD	1	High Power PD Interface Controller (35W)	Yes (Internal 25K resistor)	N/A	4x3 DFN-12
LTC4265	PD	1	IEEE 802.3at High Power PD Interface Controller (>25.5W)	Yes, 2-Event Classification	N/A	4x3 DFN-12
LTC4268-1	PD	1	High Power PD Interface Controller with Integrated Synchronous Switching Regulator (35W)	Yes (Internal 25K resistor)	N/A	7x4 DFN-32
LTC4269-1/2	PD	1	IEEE 802.3at High Power PD Interface Controller and Integrated Switching Regulator with Aux Support (>25.5W)	Yes, 2-Event Classification	N/A	7x4 DFN-32
LTC4278	PD	1	IEEE 802.3at High Power PD and Synchronous No-Opto Flyback Controller with 10V Aux Support (>25.5W)	Yes, 2-Event Classification	N/A	7x4 DFN-32
LTC4263-1	PSE	1	Single IEEE 802.3af PSE Controller with Internal Switch (30W)	Yes	Yes (DC or AC-Current)	4x3 DFN-14 SO-14
LTC4266	PSE	4	Quad IEEE 802.3at PSE Controller with DC Disconnect (30W and Proprietary High Power Levels)	Yes, 2-Event Classification	Yes (DC-Current)	7x7 QFN SSOP-36

Rugged Serial Interface Transceivers

Linear Technology offers a broad selection of industry standard, low power RS485/RS422, RS232/RS562 and CAN interface transceivers featuring high ESD protection, high speed and high voltage versions for rugged environments. Our family of RS485 transceivers includes models that feature fail-safe receiver inputs that guarantee a receiver output high for shorted, open or inactive data lines. Select models feature slew rate limiting to lower EMI, while others include a receiving logic-selectable 120Ω termination. All devices are designed to operate in systems with either 3.3V or 5V supplies, possess a maximum data rate of 20Mbps and maintain a high input impedance capable of supporting up to 256 nodes. Fault-protected devices are equipped with ±60V overvoltage protection, eliminating a common cause of failure, cross-wiring bus terminals to a supply rail. Our transceivers are equipped with enhanced on-chip ESD protection, up to ±25kV HBM, which guarantees no damage or latchup can occur.

LTC2854: 3.3V 20Mbps RS485/RS422 Transceiver with Integrated Switchable Termination

Features:

- Integrated, Logic-Selectable 120Ω Termination Resistor
- 3.3V Supply Voltage
- 20Mbps Maximum Data Rate
- No Damage or Latchup Up to ±25kV HBM
- High Input Impedance Supports 256 Nodes (C, I-Grade)
- Operation Up to 125°C (H-Grade)
- Guaranteed Failsafe Receiver Operation Over the Entire Common Mode Range
- Current Limited Drivers and Thermal Shutdown
- Delayed Micropower Shutdown: 5μA Maximum (C, I-Grade)
- Power Up/Down Glitch-Free Driver Outputs
- Low Operating Current: 370μA Typical in Receive Mode
- Compatible with TIA/EIA-485-A Specifications

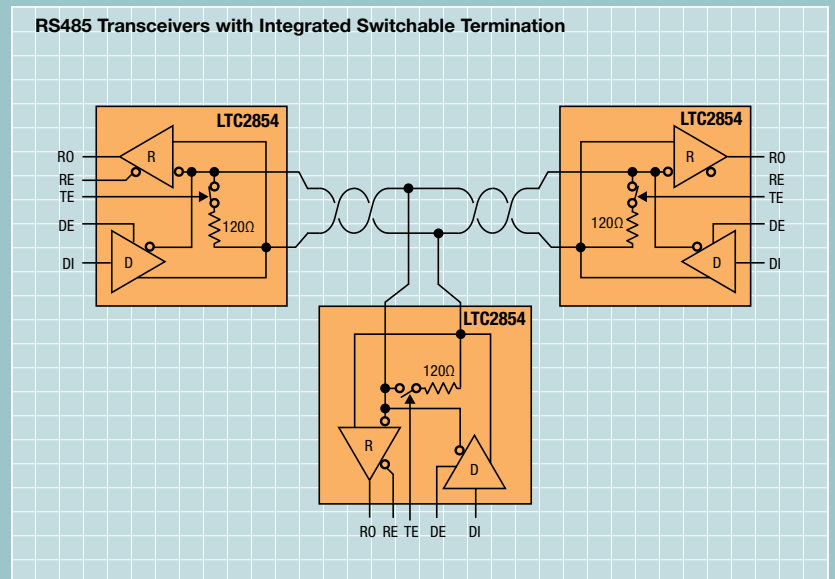

Part Number	Standard	Bus Voltage Protection	ESD	Maximum Ambient Temperature	Description	Packages
Fault-Protected Transceivers						
LT1785	RS485	±60V	±15kV	85°C	Standard Pinout, Half-Duplex	SO-8, DIP-8
LT1796	CAN	±60V	±15kV	85°C	Standard SO-8 Pinout, 125kBaud	SO-8, DIP-8

Part Number	Number of Drivers	Number of Receivers	Supply Voltage (V)	Power (mW)	ESD	Driver Disable	Shutdown	Packages
RS232/RS562 Transceivers								
LTC2801/2	1	1	1.8	8	±10kV	Yes	Yes	4x3 DFN-12
LT1781	2	2	5	40	±15kV	No	No	SO-16, SW-16, N-16
LTC2803/4	2	2	1.8	8	±10kV	Yes	Yes	5x3 DFN-16, SSOP-16
LT1137A	3	5	5	60	±15kV	Yes	Yes	SSOP-28, SW-28, N-28
LTC1348	3	5	3	1.5	±10kV	No	Yes	SSOP-28, SW-28

Part Number	Number of Drivers	Number of Receivers	Configuration	Supply Voltage (V)	Max Data Rate (Mbps)	ESD	Temperature Grades	Description	Packages
RS485/RS422 Transceivers									
LTC1480	1	1	Half-Duplex	3.3	2.5	±10kV	I	3.3V Operation	SO-8, DIP-8
LTC1535	1	1	Full-Duplex	5	0.35	±8kV	I	2500V Isolation	SO-28
LT1785	1	1	Half-Duplex	5	0.25	±15kV	I	+/-60V Fault-Protected, Failsafe	SO-8, DIP-8
LT1791	1	1	Full-Duplex	5	0.25	±15kV	I	+/-60V Fault-Protected, Failsafe	SO-14, DIP-14
LTC2852	1	1	Full-Duplex	3.3	20	±15kV	I, H	3.3V, 20Mbps, Failsafe	DFN-10, MS-10, SO-14
LTC2854	1	1	Half-Duplex	3.3	20	±15kV	I, H	3.3V 20Mbps, Integrated Switchable Termination	DFN-10
LTC2858-1/-2	1	1	Full-Duplex	5	20	±15kV	I, H	20Mbps (-1) or 0.25Mbps (-2), Failsafe, SR Limited 15kV	MS-10, DFN-10
LTC2861	1	1	Full-Duplex	5	20	±15kV	I	20Mbps, Integrated Switchable Termination	DFN-12, SSOP-16

Part Number	Number of Drivers	Number of Receivers	Supply Voltage (V)	ESD (kV)	Protocols Supported	Packages
Multiprotocol Transceivers						
LTC1387	2	2	5	±4kV	RS232, RS422, RS485	SSOP-20, SW-20
LTC1334	4	4	5	±4kV	RS232, RS422, RS485	SSOP-28, SW-28, N-28

I²C and SMBus Buffers and Accelerators

Linear Technology bus buffers and rise time accelerators offer capacitive isolation and active pull-up currents to eliminate common 2-wire bus problems that occur when many nodes are added to a system management bus such as I²C or SMBus. These busses are commonly used in high availability (Hot Swap) environments. The enhanced data transmission speed and reliability, coupled with robust ESD structures, makes these devices suitable for many industrial applications.

LTC4309: Level Shifting Low Offset Hot Swap Capable 2-Wire Bus Buffer with Stuck Bus Recovery

Features:

- Bidirectional Buffer Increases Fanout
- 60mV Buffer Offset Independent of Load
- Optional Disconnect when Bus is Stuck Low
- Prevents SDA and SCL Corruption During Live Board Insertion and Removal from Backplane
- Level Shift 2.5V, 3.3V and 5V Busses
- Compatible with Non-Compliant V_{OL} I²C Devices
- ±6kV Human Body Model ESD Ruggedness
- Isolates Input SDA and SCL Lines from Output
- Compatible with I²C, I²C Fast-Mode and SMBus
- READY Open Drain Output
- FAULT Open Drain Output
- 1V Precharge on All SDA and SCL Lines
- Optional Rise Time Accelerators
- High Impedance SDA, SCL Pins for $V_{CC} = 0$
- Available in Small 12-Pin DFN (4mm x 3mm) and 16-Lead SSOP Packages

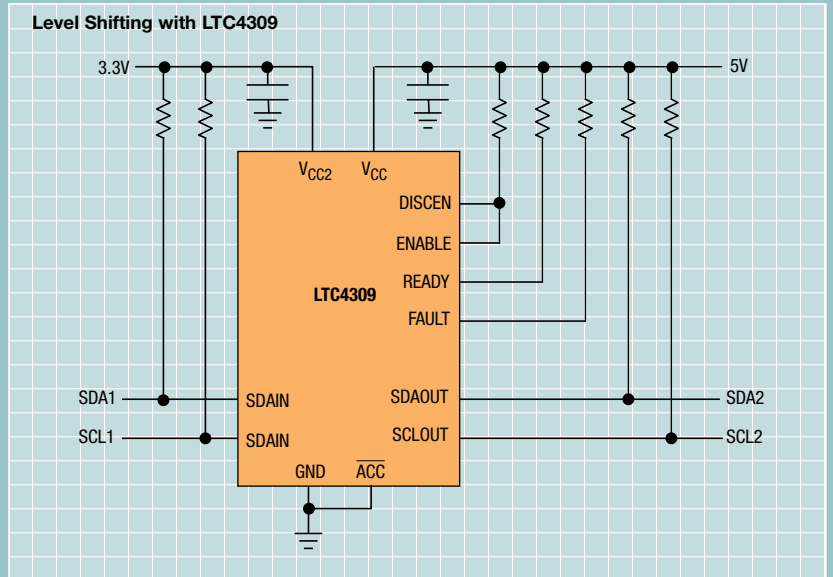

Stuck Bus Resolved with Automatic Clamping

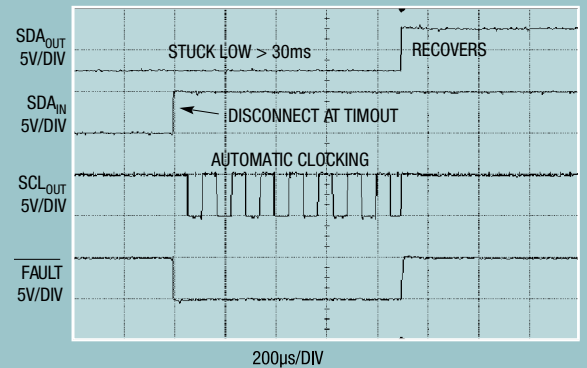

Part Number	Bus Buffer	Rise Time Acceleration	Level Translation	Maximum Data Rate	ESD	Description	Packages
I²C and SMBus Buffers and Accelerators							
LTC4311	No	Yes	No	400kHz	±8kV	Low Voltage I ² C/SMBus Accelerator	2x2 DFN-6, SC70
LTC4303	Yes	Yes	3.3V to 5V ¹	400kHz	±15kV	Hot Swap Capable, Stuck Bus Recovery	MSOP-8, 3x3 DFN-8
LTC4306	Yes	Yes	3.3V to 5V	400kHz	±10kV	4-Channel, 2-Wire Bus Multiplexer with Capacitance Buffering	SSOP-24, 4x5 QFN-24
LTC4307	Yes	Yes	No	400kHz	±5kV	Low Offset, Hot Swap Capable, Stuck Bus Recovery	MSOP-8, 3x3 DFN-8
LTC4308	Yes	Yes	1V to 2.5V/5V	400kHz	±6kV	Optimized for Low Voltage Systems Down to 0.9V	MSOP-8, 3x3 DFN-8
LTC4309	Yes	Yes	2.5V/3.3V/5V	400kHz	±6kV	Low Offset, Hot Swap Capable, Stuck Bus Recovery, Fault Flag	SSOP-16, 4x3 DFN-12

¹Buffer $V_{CC} < = V_{BUS}$

System Monitoring and Control

Linear Technology’s System Monitoring and Control portfolio includes an extensive selection of power supply voltage supervisors, power monitors, trackers, margining controllers, sequencers and pushbutton controllers designed to simplify system control. All of these devices improve DC/DC converter functionality and feature a high degree of accuracy, integration and configurability, resulting in cost-efficient designs and simplified system circuitry.

The System Monitor and Control family provides convenient all-in-one solutions for many of today’s growing digital power management applications.

Voltage Monitors and Supervisors

This family includes power supply voltage monitors ranging from 0.5V to 27V, with integration of up to eight supply monitors in tiny packages. Many of these devices feature adjustable inputs, accurate user-selectable voltage thresholds, UV/OV/Negative monitoring, watchdog timers and low supply currents.

LTC2930: Configurable Six Supply Monitor with Adjustable Reset Timer and Manual Reset

Features:

- Simultaneously Monitors Six Supplies
- 16 User Selectable Combinations of 5V, 3.3V, 3V, 2.5V, 1.8V, 1.5V and ± Adjustable Voltage Thresholds
- Guaranteed ±1.5% Threshold Accuracy
- Adjustable Reset Timeout
- Low Supply Current: 52µA
- Manual Reset Pin
- Power Supply Glitch Immunity
- Guaranteed RST for $V_{CC} \geq 1V$
- High Temperature Operation up to 125°C
- 12-Pin 3mm x 3mm DFN Package

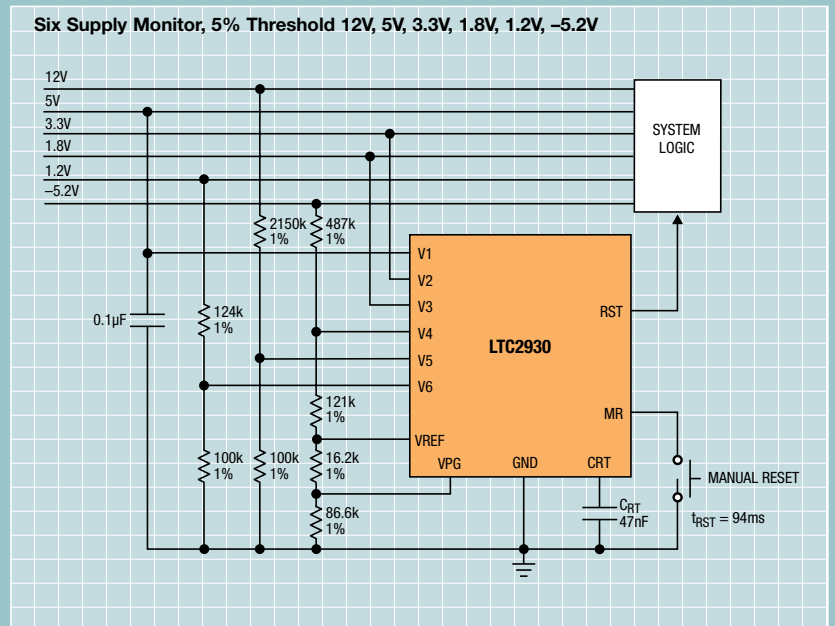

Part Number	Number of Supplies	Overvoltage Monitoring	Negative Monitoring	Watchdog Timer	Reset Pulse Width	Temperature Grades	Description	Packages
Voltage Monitors and Supervisors								
LTC2917/2918	1	No	No	Yes	Adj	C, I, H	Low Voltage with 27 Selectable Thresholds and Watchdog Timer	MS-10, DFN-10
LTC2904/05	2	No	No	No	200ms/Adj	C, I	Pin-Selectable Thresholds and Tolerances of 5%, 7.5%, 10%	SOT-23-8 DFN-8
LTC1326/-2.5	3	No	No	No	200ms	C, I	Long Duration Manual Reset Input	SO-8, MS-8
LTC2914	4	Yes	Yes	No	Adj	C, I, H	Quad UV/OV Positive/Negative Voltage Monitor	SSOP-16 DFN-16
LTC2908	6	No	No	No	200ms	C, I	Precision Six Supply Monitor	SOT-23-8 DFN-8
LTC2931/2932	6	No	Yes	Yes	Adj	C, I, H	Configurable Supplies, Adj Reset Timer and Supply Tolerance	TSSOP-20
LTC2910	8	Yes	Yes	No	Adj	C, I, H	Octal Positive/Negative Voltage Monitor	SSOP-16 DFN-16

Pushbutton Controllers

Pushbutton controllers enable control for DC/DC converters, processor interrupt logic and adjustable on/off timers. They easily solve the inherent bounce problem associated with all mechanical contacts, while also enabling power supply converters and releasing a processor once the supply is fully powered up. These parts offer wide supply voltage range, small size, low quiescent current and ease of design when compared to discrete solutions.

LTC2953: Pushbutton On/Off Controller with Voltage Monitoring

Features:

- Wide Operating Voltage Range: 2.7V to 27V
- Pushbutton Control of System Power
- Low Supply Current: 14 μ A
- Power Fail Comparator Generates Warning
- UVLO Comparator Gracefully Latches Power Off
- Adjustable Supply Monitor with 200ms Reset
- Adjustable Power Down Timer
- Low Leakage EN Output (LTC2953-1) Allows DC/DC Converter Control
- High Voltage EN Output (LTC2953-2) Allows Circuit Breaker Control
- Simple Interface Allows Orderly System Power Up and Power Down
- $\pm 1.5\%$ Threshold Tolerances
- $\pm 10\text{kV}$ ESD HBM on PB Input

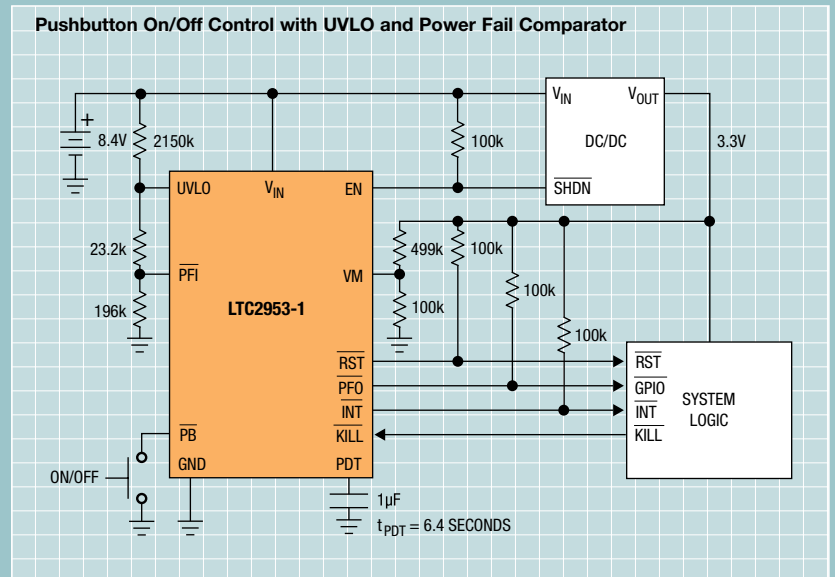

Part Number	Supply Voltage Range	I _{SUPPLY} (μA)	Description	Packages
Pushbutton Controllers				
LTC2950	2.7V to 26V	6	Active H/L Enable Output with Adjustable Pushbutton On/Off Debounce Timers	3x2 DFN-8, SOT-23
LTC2951	2.7V to 26V	6	Active H/L Enable Output with Adjustable Pushbutton Off/Kill Timers	3x2 DFN-8, SOT-23
LTC2952	2.7V to 28V	25	Pushbutton PowerPath™ Controller with Supervisor	TSSOP-20, 4x4 QFN-20
LTC2953	2.7V to 27V	14	Adjustable Power Supply Monitoring with UVLO and Power Fail Comparators	3x3 DFN-12
LTC2954	2.7V to 26V	6	Adjustable On/Off Debounce Timers. Interrupt Logic Ideal for Menu Driven Applications	3x2 DFN-8, SOT-23

LTC4150: Coulomb Counter/Battery Gas Gauge

The LTC4150 measures battery depletion and charging in handheld PC and portable product applications. The device monitors current through an external sense resistor between the battery's positive terminal and the battery's load or charger. A voltage-to-frequency converter transforms the current sense voltage into a series of output pulses at the interrupt pin. These pulses correspond to a fixed quantity of charge flowing into or out of the battery. The part also indicates charge polarity as the battery is depleted or charged. The LTC4150 is intended for 1-cell or 2-cell Li-Ion and 3-cell to 6-cell NiCd or NiMH applications.

Features:

- Indicates Charge Quantity and Polarity
- $\pm 50\text{mV}$ Sense Voltage Range
- Precision Timer Capacitor or Crystal Not Required
- 2.7V to 8.5V Operation
- High Side Current Sense
- 32.55Hz/V Charge Count Frequency
- 1.5 μA Shutdown Current
- 10-Lead MSOP Package

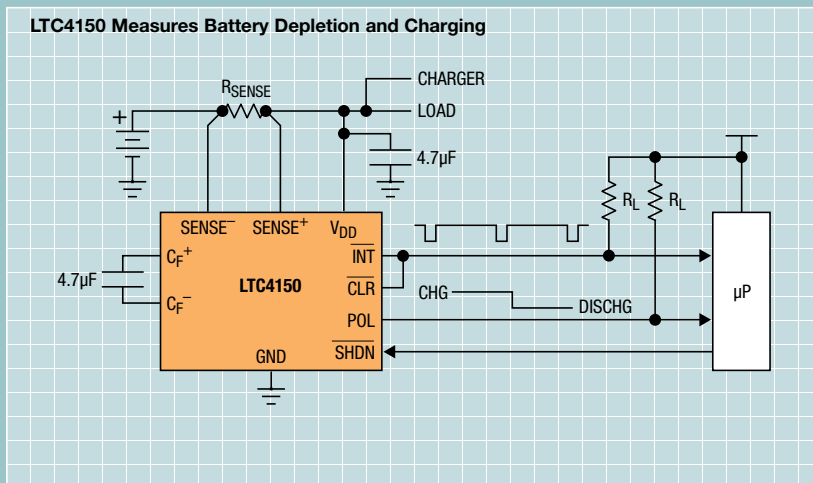

LTC4151: High Voltage I²C Current and Voltage Monitor

The LTC4151 and LTC4151-1 are high side power monitors that operate over a wide voltage range of 7V to 80V. In default operation, the onboard 12-bit ADC continuously measures high side current, input voltage and an external voltage. Data is reported through the I²C interface when polled by a host. The monitors can also perform on-demand measurement in a snapshot mode. The LTC4151 features a dedicated shutdown pin to reduce power consumption. The LTC4151-1 features split I²C data pins with data in and an inverted data output to drive optoisolators.

Features:

- Wide Operating Voltage Range: 7V to 80V
- 12-Bit Resolution for Both Current and Voltages
- I²C Interface
- Additional ADC Input Monitors an External Voltage
- Continuous Scan and Snapshot Modes
- Shutdown Mode (LTC4151) Reduces Quiescent Current to 120 μA
- Split SDA for Optoisolation (LTC4151-1)
- Tiny 10-Lead MSOP and 3mm \times 3mm DFN Packages

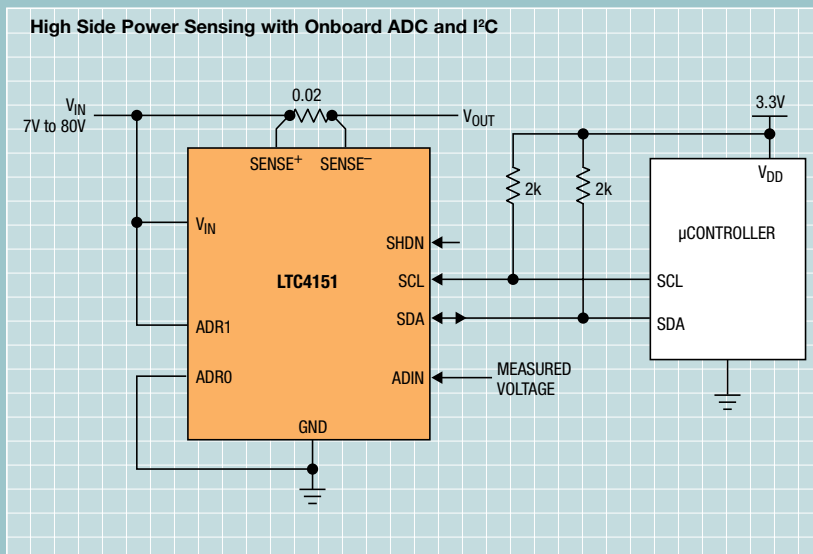

Supply Trackers, Sequencers and Margining Controllers

Energy efficiency and power consumption are critical factors in today's electronic designs. With many different voltage rails supplying large load currents, managing power consumption and optimizing, overall efficiency can be a challenge. This family of power supply controllers allows users to select the sequence of power supply ramp-up and ramp-down, and actively control the outputs, including support for DC/DC converter modules. In addition, users have the option of tracking supplies in a coincident, offset or ratiometric fashion, as well as margining the supplies, and allow for the testing of supply voltage limits as specified by the system.

The LTC2970 and LTC2978, dual and octal controllers, offer digital power management of analog supplies to ensure precise trimming, margining and monitoring using on-chip high resolution ADCs and DACs. The LTC2970/LTC2978 work with almost any power supply, allowing designers to choose the optimal DC/DC converter that provides smooth control of the output voltage and a fast transient response. An on-chip reference and high accuracy $\Delta\Sigma$ A/D converter ensure accurate measurements of supply voltages, load currents or temperature. Voltage-buffered DACs drive the supplies' feedback nodes for improved accuracy and can be programmed by a slow, linear voltage servo to trim and margin the output voltages. This is extremely useful in determining the load's sensitivity to the power supply during the prototype phase or to test for manufacturing variations in production.

Extensive, user-configurable fault monitoring provides increased reliability, alerting a system's host to incipient failures before they occur. The LTC2978 also includes a configuration EEPROM with fault logging. The $\Delta\Sigma$ ADC architecture was specifically chosen to average out power supply noise and allow fast transients. The point of load ground reference for the DAC outputs minimizes errors that would otherwise occur in a power system that experiences ground bounce.

LTC2978: Octal PMBus Power Supply Monitor and Controller with EEPROM

Features:

- PMBus Compliant Interface and Command Set
- Configuration EEPROM
- Fault Logging to Internal EEPROM
- Differential Input, 15-Bit $\Delta\Sigma$ ADC with Less Than $\pm 0.25\%$ of Total Unadjusted Error
- Monitors Eight Output Channels and One Input Voltage 8-Channel Sequencer
- Programmable Watchdog Timer
- Eight UV/OV Voltage Supervisors
- Eight 10-Bit Voltage-Buffered IDACs with Soft Connect
- Linear, Voltage Servo Adjusts Supply Voltages by Ramping Voltage-Buffered IDAC Outputs Up/Down
- Supports Multichannel Fault Management
- On-Chip Digital Temperature Sensor
- 64-Pin 9mm x 9mm QFN Package

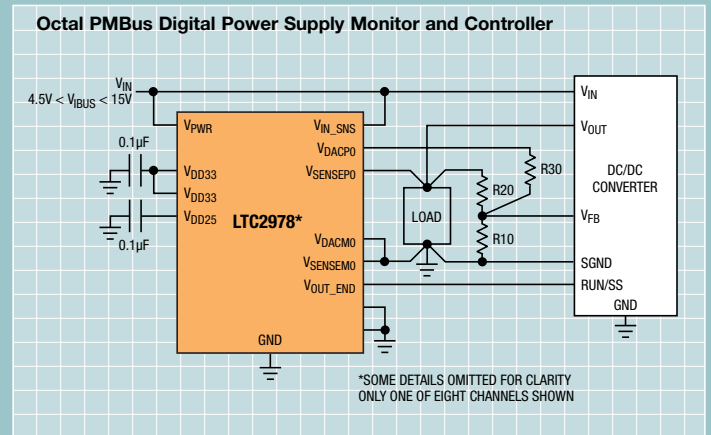

Part Number	Total Supplies	Supply Voltage (V)	Tracking via DC/DC Feedback	Sequencing	Input Monitors	Margining	PWRGD	Description	Package
Supply Tracker, Sequencers and Margining Controllers									
LTC2970	2	5 or 12	Coincident, Up and Down (LTC2970-1 Only)	Yes	6 (14-Bit ADC)	Yes (8-Bit DAC)	Yes	Dual Digital Power Monitor and Margining Controller, $\pm 0.5\%$ Unadjusted Error, Internal Temp Sensor, Automatic Servo to Programmed Voltage, UV/OV and Current Measurements. I ² C Interface	4x5 QFN-24
LTC2978	8	3 to 15	No	Yes	9 (15-Bit ADC)	Yes (10-Bit DAC)	Yes	Octal PMBus Digital Power Monitor and Margining Controller, Configurable EEPROM, $\pm 0.5\%$ Unadjusted Error, Internal Temp Sensor, Automatic Servo to Programmed Voltage, Fault Logging, UV/OV and Current Measurements	9x9 QFN-64
LTC2923	3	2.9 to 5.5	Flexible ¹	Yes	0	No	No	Tracking for Two Supplies without Series FET or a Third Supply with a series FET	4x3 DFN-12 MSOP-10
LTC2928	4	2.9 to 16.5	No	Yes	4	No	Yes	H/W Configuration of Power Turn-On/Off Sequence with Adjustable Time Positions.	SSOP-36 5 x 7 DFN-38
LTC2924	4	3 to 6.5	No	Yes	4	No	No	On/Off Power Supply Sequencer	SSOP-16

¹Flexible Tracking = Coincident, Ratiometric or Offset

Sales Offices

NORTH AMERICA

NORTHERN CALIFORNIA/NEVADA

Bay Area

720 Sycamore Dr.
Milpitas, CA 95035
Tel: (408) 428-2050
Fax: (408) 432-6331

Sacramento / Nevada

2260 Douglas Blvd., Ste. 280
Roseville, CA 95661
Tel: (916) 787-5210
Fax: (916) 787-0110

PACIFIC NORTHWEST

Denver

7007 Winchester Cir., Ste. 130
Boulder, CO 80301
Tel: (303) 926-0002
Fax: (303) 530-1477

Portland

5005 SW Meadows Rd., Ste. 410
Lake Oswego, OR 97035
Tel: (503) 520-9930
Fax: (503) 520-9929
Salt Lake City
Tel: (801) 731-8008

Seattle

2018 156th Ave. NE, Ste. 100
Bellevue, WA 98007
Tel: (425) 748-5010
Fax: (425) 748-5009

SOUTHWEST AREA

Los Angeles

21243 Ventura Blvd., Ste. 238
Woodland Hills, CA 91364
Tel: (818) 703-0835
Fax: (818) 703-0517

Orange County

15375 Barranca Pkwy., Ste. A-213
Irvine, CA 92618
Tel: (949) 453-4650
Fax: (949) 453-4765

Phoenix

2085 E. Technology Cir., Ste. 101
Tempe, AZ 85284
Tel: (480) 777-1600
Fax: (480) 838-1104

San Diego

5090 Shoreham Place, Ste. 110
San Diego, CA 92122
Tel: (858) 638-7131
Fax: (858) 638-7231

CENTRAL AREA

Chicago

2040 E. Algonquin Rd., Ste. 512
Schaumburg, IL 60173
Tel: (847) 925-0860
Fax: (847) 925-0878

Cleveland

7550 Lucerne Dr., Ste. 106
Middleburg Heights, OH 44130
Tel: (440) 239-0817
Fax: (440) 239-1466

Columbus

Tel: (614) 488-4466

Detroit

39111 West Six Mile Road
Livonia, MI 48152
Tel: (734) 779-1657
Fax: (734) 779-1658

Indiana

Tel: (847) 925-0860

Iowa

Tel: (847) 925-0860

Kansas

Tel: (913) 829-8844

Minneapolis

7805 Telegraph Rd., Ste. 225
Bloomington, MN 55438
Tel: (952) 903-0605

Wisconsin

Tel: (262) 859-1900

NORTHEAST AREA

Boston

15 Research Place
North Chelmsford, MA 01863
Tel: (978) 656-4750
Fax: (978) 656-4760

Connecticut

Tel: (860) 228-4104

Philadelphia

3220 Tillman Dr., Ste. 120
Bensalem, PA 19020
Tel: (215) 638-9667
Fax: (215) 638-9764

SOUTHEAST AREA

Atlanta

Tel: (770) 888-8137

Austin

8500 N. Mopac, Ste. 603
Austin, TX 78759
Tel: (512) 795-8000
Fax: (512) 795-0491

Dallas

2301 W. Plano Pkwy., Ste. 109
Plano, TX 75075
Tel: (972) 733-3071
Fax: (972) 380-5138

Fort Lauderdale

Tel: (954) 473-1212

Houston

1080 W. Sam Houston Pkwy., Ste. 225
Houston, TX 77043
Tel: (713) 463-5001
Fax: (713) 463-5009

Huntsville

Tel: (256) 881-9850

Orlando

Tel: (407) 688-7616

Raleigh

15100 Weston Pkwy., Ste. 202
Cary, NC 27513
Tel: (919) 677-0066
Fax: (919) 678-0041

Tampa

Tel: (813) 634-9434

CANADA

Calgary, AB

Tel: (403) 455-3577

Montreal, QC

Tel: (450) 689-2660

Ottawa, ON

Tel: (450) 689-2660

Toronto, ON

Tel: (440) 239-0817

Vancouver, BC

Tel: (604) 729-1204

ASIA

AUSTRALIA/NEW ZEALAND

Linear Technology Corporation

133 Alexander Street
Crowds Nest NSW 2065
Australia
Tel: +61 (0)2 9432 7803
Fax: +61 (0)2 9439 2738

CHINA

Linear Technology Corp. Ltd.

Units 1503-04, Metroplaza Tower 2
223 Hing Fong Road
Kwai Fong, N.T., Hong Kong
Tel: +852 2428-0303
Fax: +852 2348-0885

Linear Technology Corp. Ltd.

Room 2701, City Gateway
No. 398 Cao Xi North Road
Shanghai, 200030, PRC
Tel: +86 (21) 6375-9478
Fax: +86 (21) 5465-5918

Linear Technology Corp. Ltd.

Room 816, 8/F
China Electronics Plaza B
No. 3 Dan Ling Rd., Hai Dian District
Beijing, 100080, PRC
Tel: +86 (10) 6801-1080
Fax: +86 (10) 6805-4030

Linear Technology Corp. Ltd.

Room 2604, 26/F
Excellence Times Square Building
4068 YiTian Road, Futian District
Shenzhen, 518048, PRC
Tel: +86 755-8236-6088
Fax: +86 755-8236-6008

JAPAN

Linear Technology KK

8F Shuwa Kioicho Park Bldg.
3-6 Kioicho Chiyoda-ku
Tokyo, 102-0094, Japan
Tel: +81 (3) 5226-7291
Fax: +81 (3) 5226-0268

Linear Technology KK

6F Kearny Place Honmachi Bldg.
1-6-13 Awaza, Nishi-ku
Osaka-shi, 550-0011, Japan
Tel: +81 (6) 6533-5880
Fax: +81 (6) 6543-2588

Linear Technology KK

7F Sakuradori Ohtsu KT Bldg.
3-20-22 Marunouchi, Naka-ku
Nagoya-shi, 460-0002, Japan
Tel: +81 (52) 955-0056
Fax: +81 (52) 955-0058

KOREA

Linear Technology Korea Co., Ltd.

Yundang Building, #1002
Samsung-Dong 144-23
Kangnam-Ku, Seoul
135-090 Korea
Tel: +82 (2) 792-1617
Fax: +82 (2) 792-1619

SINGAPORE

Linear Technology Pte. Ltd.

507 Yishun Industrial Park A
Singapore 768734
Tel: +65 6753-2692
Fax: +65 6752-0108

TAIWAN

Linear Technology Corporation

8F-1, 77, Nanking E. Rd., Sec. 3
Taipei, Taiwan
Tel: +886 (2) 2505-2622
Fax: +886 (2) 2516-0702

EUROPE

FINLAND

Linear Technology AB

Teknobulevardi 3-5
P.O. Box 35
FIN-01531 Vantaa
Finland
Tel: +358 (0)46 712 2171
Fax: +358 (0)46 712 2175

FRANCE

Linear Technology S.A.R.L.

Parc Tertiaire Silic
2 Rue de la Couture, BP10217
94518 Rungis Cedex
France
Tel: +33 (1) 56 70 19 90
Fax: +33 (1) 56 70 19 94

GERMANY

Linear Technology GmbH

Osterfeldstrasse 84, Haus C
D-85737 Ismaning
Germany
Tel: +49 (89) 962455-0
Fax: +49 (89) 963147

Linear Technology GmbH

Haselburger Damm 4
D-59387 Ascheberg
Germany
Tel: +49 (2593) 9516-0
Fax: +49 (2593) 951679

Linear Technology GmbH

Jesinger Strasse 65
D-73230 Kirchheim/Teck
Germany
Tel: +49 (0)7021 80770
Fax: +49 (0)7021 807720

ITALY

Linear Technology Italy Srl

Orione 3, C.D. Colleoni
Via Colleoni, 17
I-20041 Agrate Brianza (MI)
Italy
Tel: +39 039 596 5080
Fax: +39 039 596 5090

SWEDEN

Linear Technology AB

Electrum 204
Isafjordsgatan 22
SE-164 40 Kista
Sweden
Tel: +46 (8) 623 16 00
Fax: +46 (8) 623 16 50

UNITED KINGDOM

Linear Technology (UK) Ltd.

3 The Listons, Liston Road
Marlow, Buckinghamshire SL7 1FD
United Kingdom
Tel: +44 (1628) 477066
Fax: +44 (1628) 478153

Linear Technology, LT, LTC, LTM, PolyPhase, µModule, and the Linear Logo are registered trademarks and Hot Swap, PowerPath and ThinSOT are trademarks of Linear Technology Corporation. All other trademarks are the property of their respective owners.