

Images Scientific Instruments Inc.
109 Woods of Arden Road
Staten Island NY 10312
718.966.3694 Tel.
718.966.3695 Fax
www.imagesco.com

High Voltage Power Supply

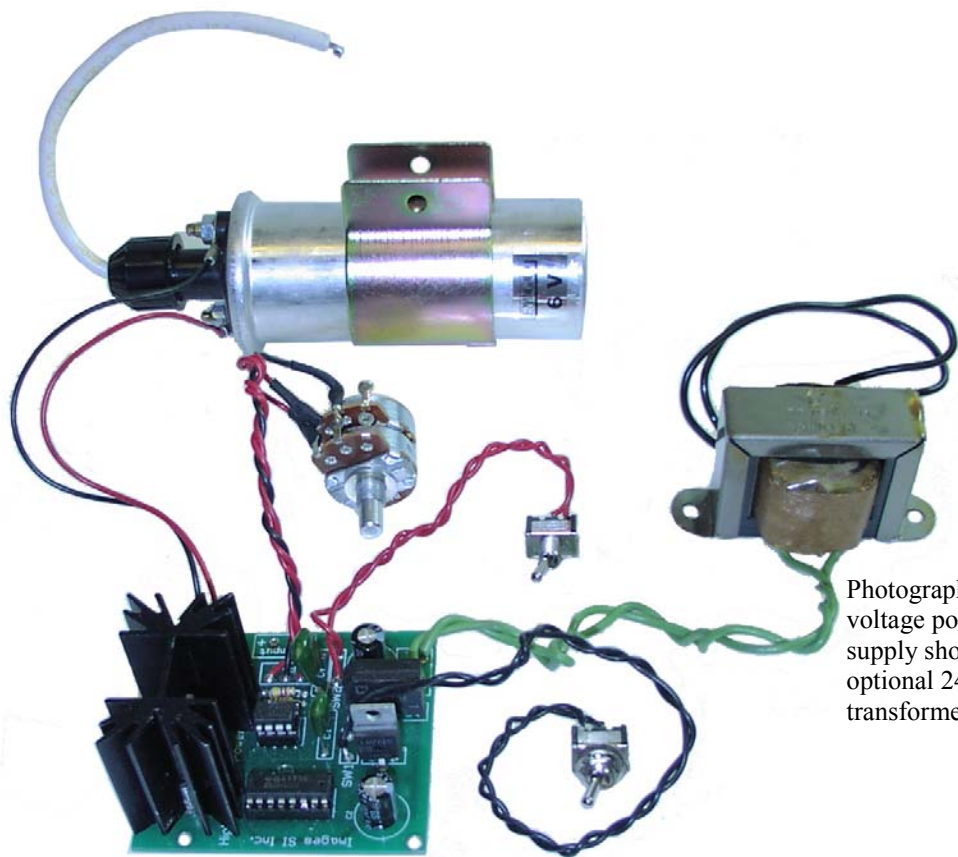

Photograph high voltage power supply shown with optional 24 VAC transformer

Important Safety Warning

This kit is not intended for children! Assembly of this kit requires high-temperature soldering and the use of sharp edged components and cutting tools. Some included components may become hot, leak, or explode if used improperly. Images strongly recommends that you wear safety glasses when building or working with any electronic equipment.

This is a high voltage power supply that is intended for use by adults. Children should not build or operate this kit.

By using this product, you agree not to hold Images liable for any injury or damage related to the use or to the performance of this product. This product is not designed for, and should not be used in, applications where the malfunction of the product could cause injury or damage.

Contacting Images SI Inc.

You can check the Images web site at <http://www.imagesco.com/> for latest information about application examples and troubleshooting tips.

We would be delighted to hear from you about your project and about your experience. You can contact us by email at imagesco@verizon.net. Tell us what we did well, what we could improve, what you would like to see in the future, or anything else you would like to say!

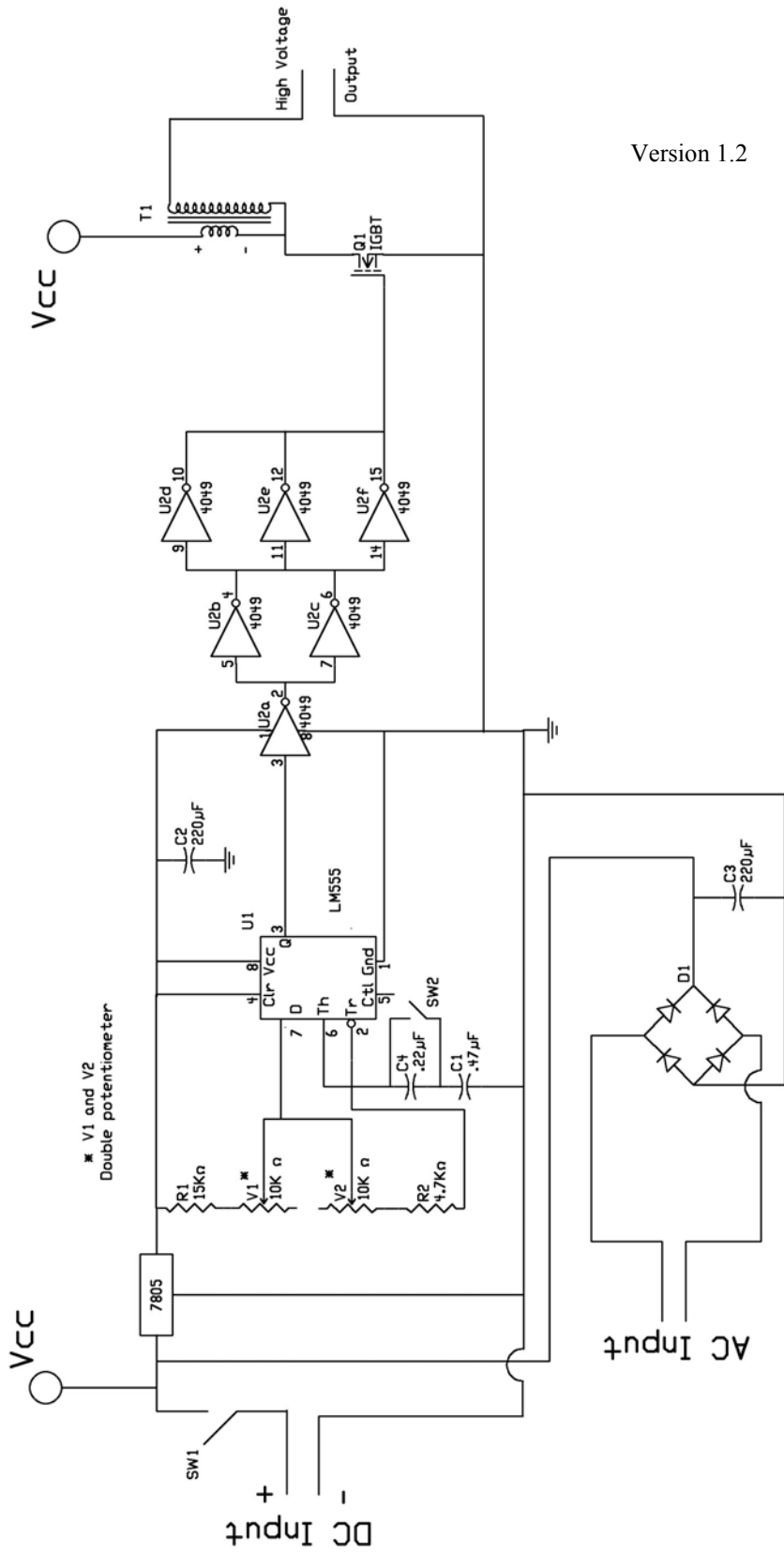

Version 1.2

Figure 1

This High Voltage power source may be used in a variety of applications, that include:

- * Kirlian photography
- * HeNe Laser tube power supply
- * X-ray tubes
- * Plasma and neon tubes
- * Negative ion generators, etc.

The power supply features variable frequency control using a potentiometer. Also has a High-Low frequency range switch. In addition this circuit to be either be battery powered 6-9 VDC, or powered from a wall transformer also 6-9 V with either an AC or DC output. When powered from batteries provides the advantage of portability for fieldwork.

How the Circuit Works

The circuit schematic for the high voltage power supply is shown in figure 1. This is a simple device that is based on the 555 timer. The 555 timer is set up as an astable oscillator. The output of the timer is fed through a series of buffers in the 4049 chip, that inverts and buffers the signal from the timer. The output signal from the buffer is fed to the base of Q1, a high voltage transistor, that turns the transistor on and off.

The frequency of the 555 timer is controlled by the potentiometer and hi-low switch that adjust the timing capacitor. The potentiometer used in this circuit is a double-ganged potentiometer. Which means that it is two potentiometers that share a common shaft. A close up of the potentiometer is shown in figure 3. The center terminal of the potentiometer is called the wiper. The two wipers of the potentiometers are soldered together and connected to pin 7 of the 555 Timer

All the current to energize the HV ignition coil passes through transistor Q1. To prevent Q1 from overheating, a large heat sink is attached.

The transformer T1 is a high voltage autotransformer. The T1 ignition coil transformer is a three terminal device. The two screw terminals are label (+) and (-). Here is where we connect power from our circuit to the coil. The center of the coil has a plastic protuberance. Inside this protuberance is a metal terminal that is the high voltage output of the transformer. A well-insulated (HV) wire is inserted inside to make the HV connection.

Construction of High Voltage Power Supply

The components are mounted on the top side of each pc board. The top side of the board has white silk screen component drawings. The components are soldered on the opposite side of the pc board. After soldering the component to the board any excess wire is clipped off.

Begin construction by mounting and soldering the 8-pin and 16 pin sockets. Insert the IC sockets, making sure to orient the notch on the socket to the drawing on the PCB and solder to the PC board.

Next mount and solder Q2 the 7805 voltage regulator. Mount and solder R1 the 4.7K resistor(color bands yellow, violet and red) and R2 the 15K (color bands brown, green, orange) resistor. Mount and solder the bridge rectifier D1, making sure to orientated the + pin of the rectifier to the silk screen. Next mount and solder capacitors C2 and C3.

Figure 2 (Version 1.2)

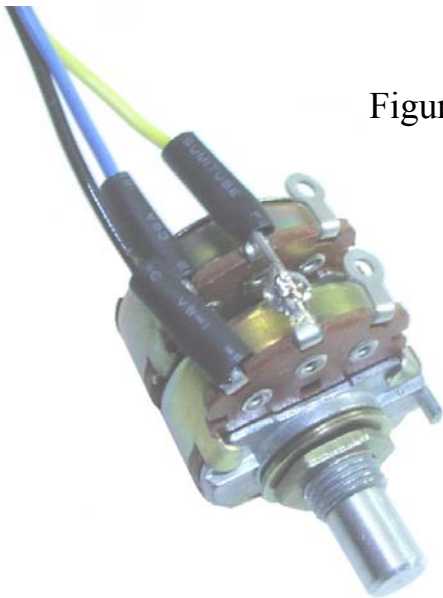
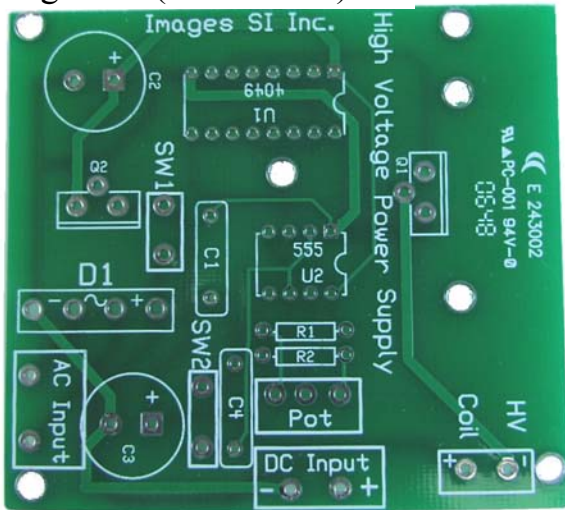

Figure 3

Wire the double ganged potentiometer as shown in figure 3. Next solder the opposite ends of the wires to the printed circuit board, in the box labeled “POT”. The center wire of the potentiometer is soldered into the center pad on the labeled box. The two end wires are soldered into the pads on either side of the center position.

Mount the Q1 transistor to the black aluminum heat sink. Next mount the heat sink and transistor to the Q1 position on the PC board. The heat sink has two feet that fit into the holes on the PC board. Solder the heat sink feet in the holes to make a mechanically strong

bond.

Attach 6 inch wires to both switches SW1 and SW2. Solder opposite ends of the wire into the pads marked SW1 and SW2 on the pc board respectively. Switch SW1 controls power to the circuit. Switch SW2 is the frequency high-low frequency control. Mount and solder capacitors C1 and C4 to the pc board. Solder two 10” lengths of wire to the HV coil pads on the PC board. Attach the opposite ends on these wires to the HV coil as shown in figure 4. Making sure to place the + lead to the + terminal on the HV coil. See figure 4

Figure 4



Strip about 2-3 inches (50-75 mm) of insulation off of high voltage wire. Bend the bare wire into a “J” or “U” shape. Insert the wire into the center terminal of the ignition coil. If you purchase the new coil, you will have a rubber grommet and a screw top for the center terminal. Thread the wire through the grommet (first) and then the screw on top. Rest the grommet on top of the center terminal, then screw on the top of the ignition coil. The grommet will collapse locking the HV wire into the center terminal, see close-up in figure 4.

Attach power leads to either the AC input or DC input pads on the PC board.

Next install the two integrated circuits. When installing integrated circuit (IC) chips, begin by first identifying the top of the chip. The top of the chip has a marker, many times it is a half circle cutout. Sometimes it is a small mark identifying pin 1 on the IC. In both cases the marks show us the top of the IC chip. Orientated the top of IC chips with the white silk screen drawings of the components on the top of the pc board (usually a half circle cutout) or on the parts placement drawings and install the IC into their socket.

Testing & Finishing Construction

To test the circuit, take the open end of the HV wire and place it about ¼” away from the (-) terminal on the ignition coil. Apply power to the circuit. An electrical discharge should jump between the HV wire and the negative terminal of the ignition coil. Adjust the potentiometer (frequency control) to obtain the largest spark across the discharge.

If you do not get a continuous HV spark, you have a board error. Go back to your pc board and start checking your components and soldering.

The working circuit ought to be mounted inside a plastic enclosure. Coat any exposed wires with a plastic spray to provide insulation (No-Arc spray is available at your local Radio-Shack stores, or corona dope is another insulating material. In a pinch you can use clear nail polish. Since nail polish is flammable, allow the nail polish to complete dry before using the circuit.)

Frequency & Voltage Output

Using the standard C1 and C4 capacitors the low frequency range is approximately 120-250 Hz. The high frequency range is approximately 200-400 Hz. Using a 24 VDC input voltage to the circuit, the voltage output, measured using a spark gap and spherical electrodes is approximately 30-40 KV. By changing the capacitors C1 and C2, one can vary the operating frequency and output voltage of the circuit, see chart below.

C1(uF)	C2(uF)	Low Frequency Range	High Frequency Range	Output Voltage	Input Voltage
.047	.1	500 Hz - 1250 Hz	1000 Hz—2000 Hz	7-17 kV	24 VDC
.22	.22	125 Hz - 250 Hz	250 Hz - 500 Hz	8—32 kV	24 VDC
.22	.47	120 Hz - 250 Hz	200 Hz - 400 Hz	30 - 40 kV	24 VDC *
1.0	1.0	25 Hz - 66 Hz	50 Hz - 110 Hz	25 kV - 46 kV	24 VDC

* Standard Device

Parts List (version 1.2)

C1	.47 uF capacitor
C4	.22 uF capacitor
C2,C3	100-500 uF capacitors
Q1	HV Transistor
Q2	7805 Voltage Regulator
U1	4049 hex inverting buffer
U2	LM555 Timer

T1	HV auto ignition coil
R1	4.7 K 1/4 watt resistor
R2	15K 1/4 watt resistor
D1	Bridge rectifier
SW1,SW2	SPST toggle switch
POT	double ganged 10K potentiometer
MISC—	8 pin socket, 16 pin socket, wire, HV wire

How to Solder



This page provides the basic steps for soldering electronic components onto a pc board.

Soldering Iron, small sponge, electronic rosin core solder, side cutters and needle nose pliers.

Step 1:

Turn on soldering iron. Moisten small sponge with water. When soldering iron is hot, tin the soldering iron tip using a small amount of rosin core solder. Melt the solder onto the tip until the tip is completely covered with solder. Excess solder on the tip may be removed by wiping the tip across the wet sponge. Keep the tip clean by wiping the iron across the wet sponge periodically.

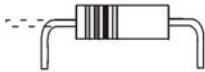

Step 2:

Bend the component leads to fit inside the PC board holes



Step 3:

Insert the component into the pc board, taking care to orientate the component as described in the directions. Bend the leads slightly to hold the part into position

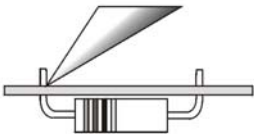

Step 4:

Tin soldering iron tip if necessary. Heat the joint by positioning soldering iron tip against the component lead and the pc board lead.

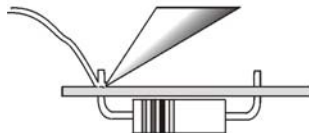

Step 5

After a few moments of heating, apply the solder to the joint. The solder should flow easily around the joint. After the solder flows, remove the solder, while keeping the soldering iron tip in contact. Then remove the soldering iron tip.

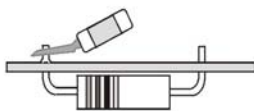

Step 6:

Trim the excess component lead from the bottom of the pc board using the side cutters.

Step 7: Inspect the solder connection

A good solder connection joints the component lead and pad together and has a bright finish. If the connection is a glob of solder that looks like a ball, or bridges other solder connections.. Reflow the connection by remelting the connection using the soldering iron. Do not apply any more solder.

Resistor Color Code

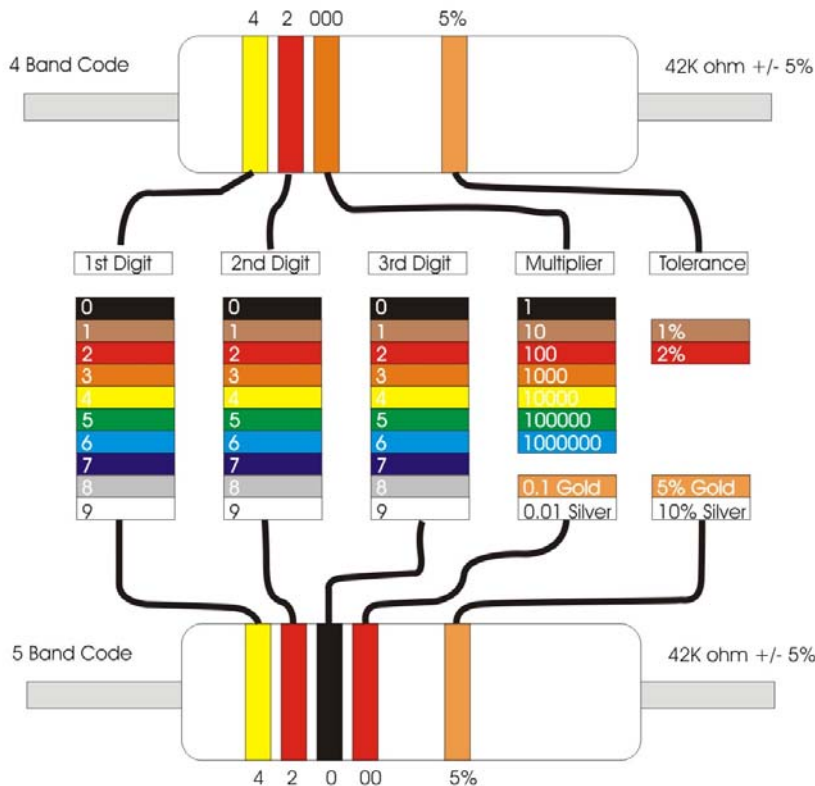

Appendix A Determining Resistor Values:

Resistor values are read using the color bands on the body of the resistor. The first band is the one nearest the end of the resistor. Start reading from this band. The first band represents the first significant number, the second band, the second significant number and the third band is the multiplier. If the third band is gold or silver this indicates a multiplier value of .1 or .01 respectively.

Color Value Multiplier

Black	0	1
Brown	1	10
Red	2	100
Orange	3	1000
Yellow	4	10000
Green	5	100000
Blue	6	1000000
Violet	7	10000000
Gray	8	100000000
White	9	1000000000
Tolerance (%)		
Gold	5%	
Silver	10%	
No Band	20%	

Example: A resistor with the following color bands Red, Red, Orange, Silver

1st Number Red = 2
 2nd number Red = 2
 3rd Number Orange = 3 multiplier (# of zeros) that equals 1000
 Silver = 10%

Putting it all together:

Red	Red	Orange	Value	Tolerance
2	2	x 1000	= 22,000 ohms	+/- 10%