



Website: <http://biz.LGservice.com>  
E-mail: <http://www.LGService.com/techsup.html>

# COLOR MONITOR SERVICE MANUAL

CHASSIS NO. : CL-66

MODEL: FLATRON L1710S (L1710SN-AL\*\*G, AN\*\*ER)  
FLATRON L1710S(K) (L1710SN-AL\*\*B)

( ) \*\*Same model for Service

## CAUTION

BEFORE SERVICING THE UNIT,  
READ THE **SAFETY PRECAUTIONS** IN THIS MANUAL.



\*To apply the **Genesis ZAN3SL Chip**.

\*Same looking with new chassis.  
Issue Date; 2004.10



# CONTENTS

SPECIFICATIONS .....	2	SERVICE OSD .....	12
PRECAUTIONS .....	3	TROUBLESHOOTING GUIDE .....	13
TIMING CHART .....	7	WIRING DIAGRAM .....	17
BLOCK DIAGRAM .....	8	EXPLODED VIEW.....	18
DESCRIPTION OF BLOCK DIAGRAM.....	9	REPLACEMENT PARTS LIST .....	20
ADJUSTMENT .....	11	SCHEMATIC DIAGRAM.....	23

## SPECIFICATIONS

### 1. LCD CHARACTERISTICS

Type : TFT SXGA LCD  
 Size : 17 inch  
 Pixel Pitch : 0.264 (H) x 0.264 (V)  
 Color Depth : 16.2M colors  
 Electrical Interface : LVDS  
 Surface Treatment : Hard-coating(3H), Anti-Glare  
 Operating Mode : Normally White, Transmissive mode  
 Backlight Unit : Top/Bottom edge side 4-CCFL  
 (Cold Cathode Fluorescent Lamp)

### 2. OPTICAL CHARACTERISTICS

2-1. Viewing Angle by Contrast Ratio  $\geq 10$   
  
 Left : -60° min., -70°(Typ) Right : +60° min., +70°(Typ)  
 Top : +45° min., +60°(Typ) Bottom : -45°min., -60°(Typ)

2-2. Luminance : 200(min), 250(Typ)  
 2-3. Contrast Ratio : 300(min), 450(Typ)

### 3. SIGNAL (Refer to the Timing Chart)

3-1. Sync Signal  
 • Type : Separate Sync,  
 SOG (Sync On Green)  
 Composite Sync

3-2. Video Input Signal  
 1) Type : R, G, B Analog  
 2) Voltage Level : 0~0.71 V  
 a) Color 0, 0 : 0 Vp-p  
 b) Color 7, 0 : 0.467 Vp-p  
 c) Color 15, 0 : 0.714 Vp-p  
 3) Input Impedance : 75  $\Omega$

3-3. Operating Frequency  
 Horizontal : 30 ~ 83kHz  
 Vertical : 56 ~ 75Hz

### 4. Max. Resolution

Analog : 1280 x 1024 / 75Hz

### 5. POWER SUPPLY

5-1. Power : AC 100~240V, 50/60Hz , 1.0A

#### 5-2. Power Consumption

MODE	H/V SYNC	VIDEO	POWER CONSUMPTION	LED COLOR
POWER ON (NORMAL)	ON/ON	ACTIVE	less than 43 W	GREEN
STAND-BY	OFF/ON	OFF	less than 1 W	AMBER
SUSPEND	ON/OFF	OFF	less than 1 W	AMBER
DPMS OFF	OFF/OFF	OFF	less than 1 W	AMBER

### 6. ENVIRONMENT

6-1. Operating Temperature: 10°C~35°C (50°F~95°F)  
 (Ambient)  
 6-2. Relative Humidity : 10%~80%  
 (Non-condensing)  
 6-3. MTBF : 50,000 Hours(Min)

### 7. DIMENSIONS (with TILT/SWIVEL)

Width : 370 mm (14.57")  
 Depth : 222.5 mm (8.76")  
 Height : 421 mm (16.57")

### 8. WEIGHT (with TILT/SWIVEL)

Net. Weight : 6.0 kg (13.23 lbs)  
 Gross Weight : 7.6 kg (16.76 lbs)

## PRECAUTION

### WARNING FOR THE SAFETY-RELATED COMPONENT.

- There are some special components used in LCD monitor that are important for safety. **These parts are marked  on the schematic diagram and the replacement parts list.** It is essential that these critical parts should be replaced with the manufacturer's specified parts to prevent electric shock, fire or other hazard.
- Do not modify original design without obtaining written permission from manufacturer or you will void the original parts and labor guarantee.

### TAKE CARE DURING HANDLING THE LCD MODULE WITH BACKLIGHT UNIT.

- Must mount the module using mounting holes arranged in four corners.
- Do not press on the panel, edge of the frame strongly or electric shock as this will result in damage to the screen.
- Do not scratch or press on the panel with any sharp objects, such as pencil or pen as this may result in damage to the panel.
- Protect the module from the ESD as it may damage the electronic circuit (C-MOS).
- Make certain that treatment person's body are grounded through wrist band.
- Do not leave the module in high temperature and in areas of high humidity for a long time.
- The module not be exposed to the direct sunlight.
- Avoid contact with water as it may a short circuit within the module.
- If the surface of panel become dirty, please wipe it off with a softmaterial. (Cleaning with a dirty or rough cloth may damage the panel.)

### CAUTION

Please use only a plastic screwdriver to protect yourself from shock hazard during service operation.

### WARNING

#### BE CAREFUL ELECTRIC SHOCK !

- If you want to replace with the new backlight (CCFL) or inverter circuit, must disconnect the AC adapter because high voltage appears at inverter circuit about 650Vrms.
- Handle with care wires or connectors of the inverter circuit. If the wires are pressed cause short and may burn or take fire.

# SERVICING PRECAUTIONS

**CAUTION:** Before servicing receivers covered by this service manual and its supplements and addenda, read and follow the **SAFETY PRECAUTIONS** on page 3 of this publication.

**NOTE:** If unforeseen circumstances create conflict between the following servicing precautions and any of the safety precautions on page 3 of this publication, always follow the safety precautions. Remember: Safety First.

## General Servicing Precautions

1. Always unplug the receiver AC power cord from the AC power source before;
  - a. Removing or reinstalling any component, circuit board module or any other receiver assembly.
  - b. Disconnecting or reconnecting any receiver electrical plug or other electrical connection.
  - c. Connecting a test substitute in parallel with an electrolytic capacitor in the receiver.  
**CAUTION:** A wrong part substitution or incorrect polarity installation of electrolytic capacitors may result in an explosion hazard.
  - d. Discharging the picture tube anode.
2. Test high voltage only by measuring it with an appropriate high voltage meter or other voltage measuring device (DVM, FETVOM, etc) equipped with a suitable high voltage probe.  
Do not test high voltage by "drawing an arc".
3. Discharge the picture tube anode only by (a) first connecting one end of an insulated clip lead to the degaussing or kine aquadag grounding system shield at the point where the picture tube socket ground lead is connected, and then (b) touch the other end of the insulated clip lead to the picture tube anode button, using an insulating handle to avoid personal contact with high voltage.
4. Do not spray chemicals on or near this receiver or any of its assemblies.
5. Unless specified otherwise in this service manual, clean electrical contacts only by applying the following mixture to the contacts with a pipe cleaner, cotton-tipped stick or comparable non-abrasive applicator; 10% (by volume) Acetone and 90% (by volume) isopropyl alcohol (90%-99% strength)  
**CAUTION:** This is a flammable mixture.  
Unless specified otherwise in this service manual, lubrication of contacts is not required.
6. Do not defeat any plug/socket B+ voltage interlocks with which receivers covered by this service manual might be equipped.
7. Do not apply AC power to this instrument and/or any of its electrical assemblies unless all solid-state device heat sinks are correctly installed.
8. Always connect the test receiver ground lead to the receiver chassis ground before connecting the test receiver positive lead.  
Always remove the test receiver ground lead last.

9. Use with this receiver only the test fixtures specified in this service manual.

**CAUTION:** Do not connect the test fixture ground strap to any heat sink in this receiver.

## Electrostatically Sensitive (ES) Devices

Some semiconductor (solid-state) devices can be damaged easily by static electricity. Such components commonly are called *Electrostatically Sensitive (ES) Devices*. Examples of typical ES devices are integrated circuits and some field-effect transistors and semiconductor "chip" components. The following techniques should be used to help reduce the incidence of component damage caused by static by static electricity.

1. Immediately before handling any semiconductor component or semiconductor-equipped assembly, drain off any electrostatic charge on your body by touching a known earth ground. Alternatively, obtain and wear a commercially available discharging wrist strap device, which should be removed to prevent potential shock reasons prior to applying power to the unit under test.
2. After removing an electrical assembly equipped with ES devices, place the assembly on a conductive surface such as aluminum foil, to prevent electrostatic charge buildup or exposure of the assembly.
3. Use only a grounded-tip soldering iron to solder or unsolder ES devices.
4. Use only an anti-static type solder removal device. Some solder removal devices not classified as "anti-static" can generate electrical charges sufficient to damage ES devices.
5. Do not use freon-propelled chemicals. These can generate electrical charges sufficient to damage ES devices.
6. Do not remove a replacement ES device from its protective package until immediately before you are ready to install it. (Most replacement ES devices are packaged with leads electrically shorted together by conductive foam, aluminum foil or comparable conductive material).
7. Immediately before removing the protective material from the leads of a replacement ES device, touch the protective material to the chassis or circuit assembly into which the device will be installed.  
**CAUTION:** Be sure no power is applied to the chassis or circuit, and observe all other safety precautions.
8. Minimize bodily motions when handling unpackaged replacement ES devices. (Otherwise harmless motion such as the brushing together of your clothes fabric or the lifting of your foot from a carpeted floor can generate static electricity sufficient to damage an ES device.)

## General Soldering Guidelines

1. Use a grounded-tip, low-wattage soldering iron and appropriate tip size and shape that will maintain tip temperature within the range of 500° F to 600° F.
2. Use an appropriate gauge of RMA resin-core solder composed of 60 parts tin/40 parts lead.
3. Keep the soldering iron tip clean and well tinned.
4. Thoroughly clean the surfaces to be soldered. Use a small wire-bristle (0.5 inch, or 1.25cm) brush with a metal handle.

Do not use freon-propelled spray-on cleaners.

5. Use the following unsoldering technique
  - a. Allow the soldering iron tip to reach normal temperature.  
(500° F to 600° F)
  - b. Heat the component lead until the solder melts.
  - c. Quickly draw the melted solder with an anti-static, suction-type solder removal device or with solder braid.

**CAUTION:** Work quickly to avoid overheating the circuitboard printed foil.

6. Use the following soldering technique.
  - a. Allow the soldering iron tip to reach a normal temperature (500° F to 600° F)
  - b. First, hold the soldering iron tip and solder the strand against the component lead until the solder melts.
  - c. Quickly move the soldering iron tip to the junction of the component lead and the printed circuit foil, and hold it there only until the solder flows onto and around both the component lead and the foil.

**CAUTION:** Work quickly to avoid overheating the circuit board printed foil.

- d. Closely inspect the solder area and remove any excess or splashed solder with a small wire-bristle brush.

## IC Remove/Replacement

Some chassis circuit boards have slotted holes (oblong) through which the IC leads are inserted and then bent flat against the circuit foil. When holes are the slotted type, the following technique should be used to remove and replace the IC. When working with boards using the familiar round hole, use the standard technique as outlined in paragraphs 5 and 6 above.

### Removal

1. Desolder and straighten each IC lead in one operation by gently prying up on the lead with the soldering iron tip as the solder melts.
2. Draw away the melted solder with an anti-static suction-type solder removal device (or with solder braid) before removing the IC.

## Replacement

1. Carefully insert the replacement IC in the circuit board.
2. Carefully bend each IC lead against the circuit foil pad and solder it.
3. Clean the soldered areas with a small wire-bristle brush. (It is not necessary to reapply acrylic coating to the areas).

## "Small-Signal" Discrete Transistor Removal/Replacement

1. Remove the defective transistor by clipping its leads as close as possible to the component body.
2. Bend into a "U" shape the end of each of three leads remaining on the circuit board.
3. Bend into a "U" shape the replacement transistor leads.
4. Connect the replacement transistor leads to the corresponding leads extending from the circuit board and crimp the "U" with long nose pliers to insure metal to metal contact then solder each connection.

## Power Output, Transistor Device

### Removal/Replacement

1. Heat and remove all solder from around the transistor leads.
2. Remove the heat sink mounting screw (if so equipped).
3. Carefully remove the transistor from the heat sink of the circuit board.
4. Insert new transistor in the circuit board.
5. Solder each transistor lead, and clip off excess lead.
6. Replace heat sink.

## Diode Removal/Replacement

1. Remove defective diode by clipping its leads as close as possible to diode body.
2. Bend the two remaining leads perpendicular y to the circuit board.
3. Observing diode polarity, wrap each lead of the new diode around the corresponding lead on the circuit board.
4. Securely crimp each connection and solder it.
5. Inspect (on the circuit board copper side) the solder joints of the two "original" leads. If they are not shiny, reheat them and if necessary, apply additional solder.

## Fuse and Conventional Resistor

### Removal/Replacement

1. Clip each fuse or resistor lead at top of the circuit board hollow stake.
2. Securely crimp the leads of replacement component around notch at stake top.
3. Solder the connections.

**CAUTION:** Maintain original spacing between the replaced component and adjacent components and the circuit board to prevent excessive component temperatures.

### **Circuit Board Foil Repair**

Excessive heat applied to the copper foil of any printed circuit board will weaken the adhesive that bonds the foil to the circuit board causing the foil to separate from or "lift-off" the board. The following guidelines and procedures should be followed whenever this condition is encountered.

#### ***At IC Connections***

To repair a defective copper pattern at IC connections use the following procedure to install a jumper wire on the copper pattern side of the circuit board. (Use this technique only on IC connections).

1. Carefully remove the damaged copper pattern with a sharp knife. (Remove only as much copper as absolutely necessary).
2. Carefully scratch away the solder resist and acrylic coating (if used) from the end of the remaining copper pattern.
3. Bend a small "U" in one end of a small gauge jumper wire and carefully crimp it around the IC pin. Solder the IC connection.
4. Route the jumper wire along the path of the out-away copper pattern and let it overlap the previously scraped end of the good copper pattern. Solder the overlapped area and clip off any excess jumper wire.

#### ***At Other Connections***

Use the following technique to repair the defective copper pattern at connections other than IC Pins. This technique involves the installation of a jumper wire on the component side of the circuit board.

1. Remove the defective copper pattern with a sharp knife.

Remove at least 1/4 inch of copper, to ensure that a hazardous condition will not exist if the jumper wire opens.

2. Trace along the copper pattern from both sides of the pattern break and locate the nearest component that is directly connected to the affected copper pattern.
3. Connect insulated 20-gauge jumper wire from the lead of the nearest component on one side of the pattern break to the lead of the nearest component on the other side.

Carefully crimp and solder the connections.

**CAUTION:** Be sure the insulated jumper wire is dressed so the it does not touch components or sharp edges.

## TIMING CHART

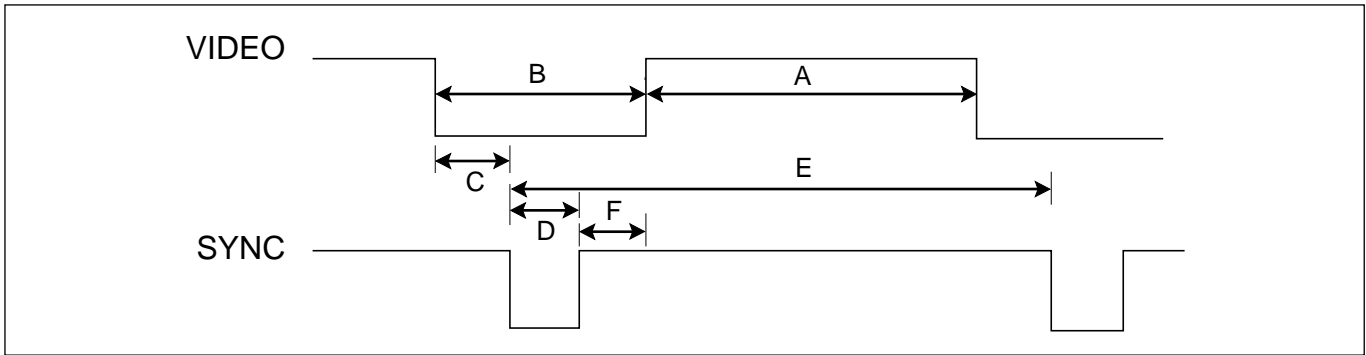

<< Dot Clock (MHz), Horizontal Frequency (kHz), Vertical Frequency (Hz), Horizontal etc... (μs), Vertical etc... (ms) >>

Mode	H/V Sort	Sync Polarity	Dot Clock	Frequency	Total Period (E)	Video Active Time (A)	Front Porch (C)	Sync Duration (D)	Back Porch (F)	Resolution
1	H	+	25.175	31.469	800	640	16	96	48	640x350 70Hz
	V	-		70.8	449	350	37	2	60	
2	H	-	28.321	31.468	900	720	18	108	54	720x400 70Hz
	V	+		70.09	449	400	12	2	35	
3	H	-	25.175	31.469	800	640	16	96	48	640x480 60Hz
	V	-		59.94	525	480	10	2	33	
4	H	-	31.5	37.5	840	640	16	64	120	640x480 75Hz
	V	-		75	500	480	1	3	16	
5	H	+	40.0	37.879	1056	800	40	128	88	800x600 60Hz
	V	+		60.317	628	600	1	4	23	
6	H	+	49.5	46.875	1056	800	16	80	160	800x600 75Hz
	V	+		75.0	625	600	1	3	21	
7	H	+/-	57.283	49.725	1152	832	32	64	224	832x624 75Hz
	V	+/-		74.55	667	624	1	3	39	
8	H	-	65.0	48.363	1344	1024	24	136	160	1024x768 60Hz
	V	-		60.0	806	768	3	6	29	
9	H	-	78.75	60.123	1312	1024	16	96	176	1024x768 75Hz
	V	-		75.029	800	768	1	3	28	
10	H	+/-	100.0	68.681	1456	1152	32	128	144	1152x900 75Hz
	V	+/-		75.062	915	870	3	3	39	
11	H	+/-	92.978	61.805	1504	1152	18	134	200	1152x900 65Hz
	V	+/-		65.96	937	900	2	4	31	
12	H	+	108.0	63.981	1688	1280	48	112	248	1280x1024 60Hz
	V	+		60.02	1066	1024	1	3	38	
13	H	+	135.0	79.976	1688	1280	16	144	248	1280x1024 75Hz
	V	+		75.035	1066	1024	1	3	38	



# BLOCK DIAGRAM

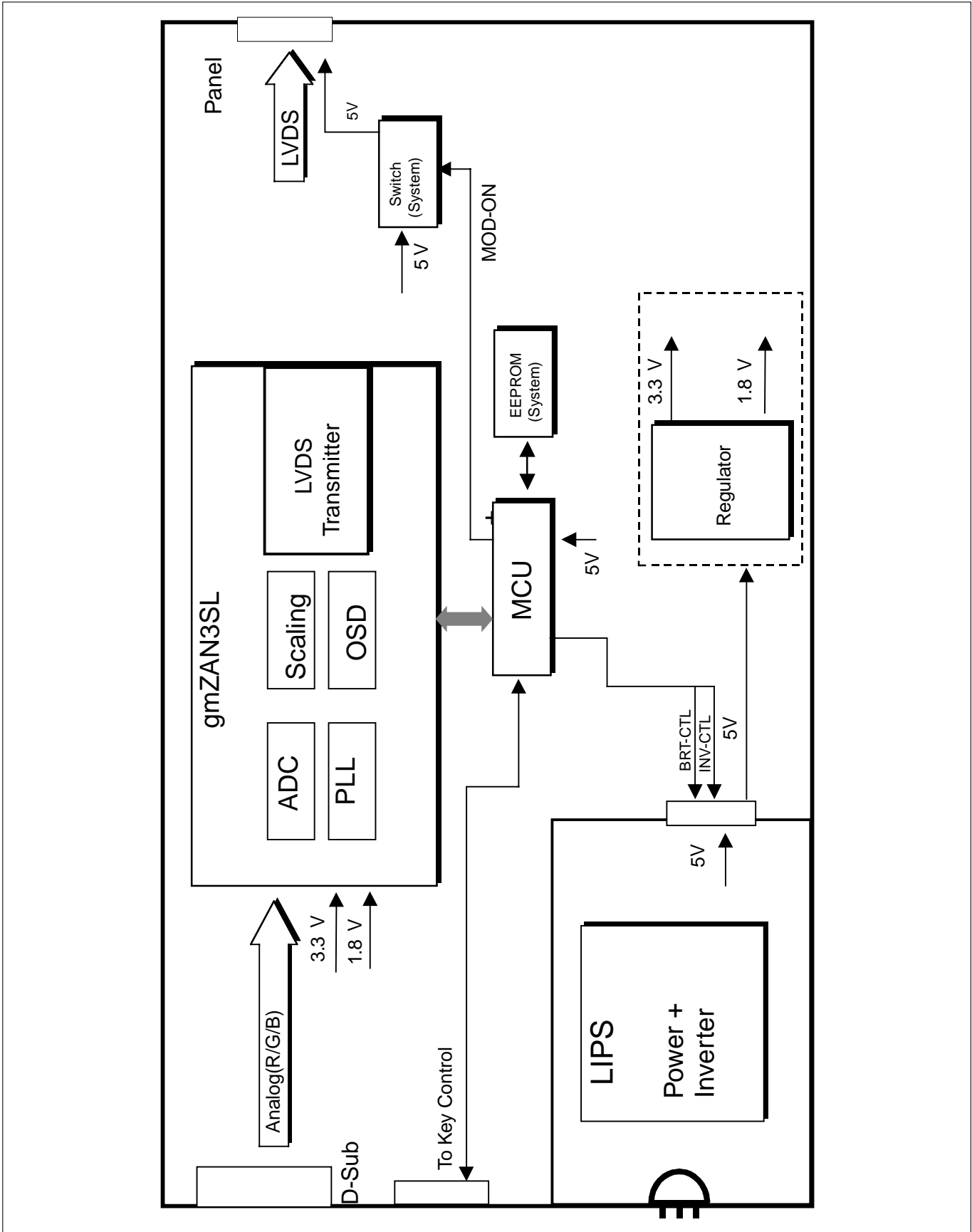

## DESCRIPTION OF BLOCK DIAGRAM

### 1. Video Controller Part.

This part amplifies the level of video signal for the digital conversion and converts from the analog video signal to the digital video signal using a pixel clock.

The pixel clock for each mode is generated by the PLL.

The range of the pixel clock is from 25MHz to 135MHz.

This part consists of the Scaler, ADC, LVDS transmitter.

The Scaler gets the video signal converted analog to digital, interpolates input to 1280 X 1024 resolution signal and outputs 8-bit R, G, B signal to transmitter.

### 2. Power Part.

This part consists of the one 3.3V regulator, and one 1.8V regulator to convert power which is provided 12V, 5V in Power board.

5V is provided for LCD panel and Micom.

Also, 5V is converted 3.3V by regulator and 3.3V is converted 1.8V by regulator.

Converted power is provided for IC in the main board.

### 3. MICOM Part.

This part consists of EEPROM IC which stores control data, Reset IC and the Micom.

The Micom distinguishes polarity and frequency of the H/V sync are supplied from signal cable.

The controlled data of each modes is stored in EEPROM.

## LIPS Board Block Diagram

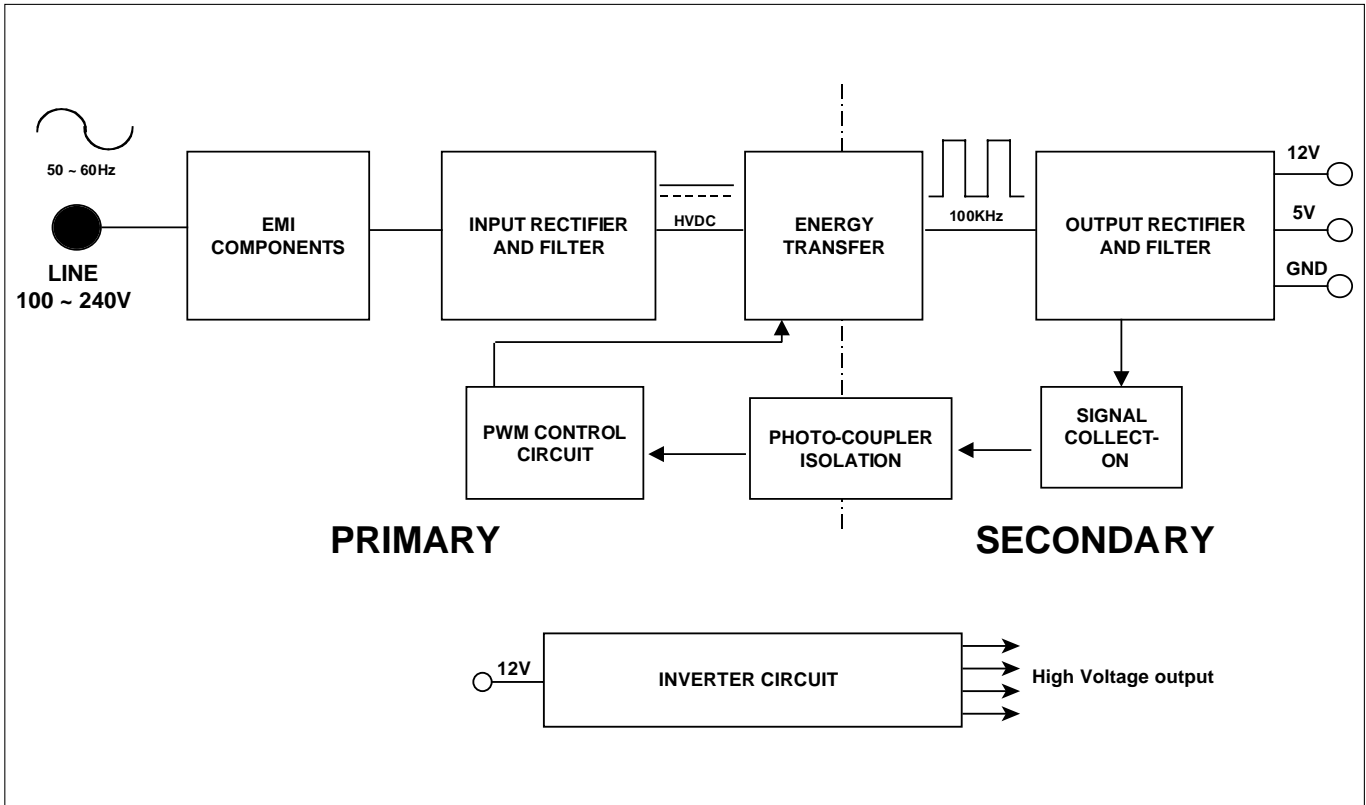

### Operation description\_LIPS

#### 1. EMI components.

This part contains of EMI components to comply with global marketing EMI standards like FCC, VCCI CISPR, the circuit included a line-filter, across line capacitor and of course the primary protection fuse.

#### 2. Input rectifier and filter.

This part function is for transfer the input AC voltage to a DC voltage through a bridge rectifier and a bulk capacitor.

#### 3. Energy Transfer.

This part function is transfer the primary energy to secondary through a power transformer.

#### 4. Output rectifier and filter.

This part function is to make a pulse width modulation control and to provide the driver signal to power switch, to adjust the duty cycle during different AC input and output loading condition to achive the dc output stabilize, and also the over power protection is also monitor by this part.

#### 5. Photo-Coupler isolation.

This part function is to feed back the dc output changing status through a photo transistor to primary controller to achieve the stabilized dc output voltage.

#### 6. Signal collection.

This part function is to collect the any change from the dc output and feed back to the primary through photo transistor.

# ADJUSTMENT

Windows EDID V1.0 User Manual

Operating System: MS Windows 98, 2000, XP  
 Port Setup: Windows 98 => Don't need setup  
 Windows 2000, XP => Need to Port Setup.  
 This program is available to LCD Monitor only.

2. EDID Read & Write
  - 1) Run WinEDID.exe

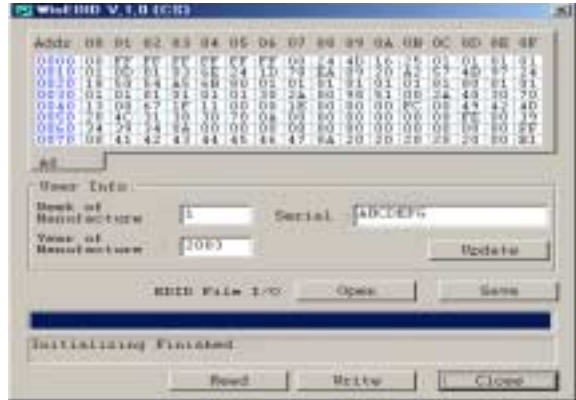

1. Port Setup
  - a) Copy "UserPort.sys" file to "c:\WINNT\system32\drivers" folder
  - b) Run Userport.exe

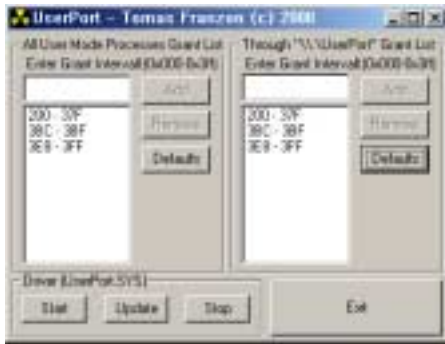

- 2) Edit Week of Manufacture, Year of Manufacture, Serial Number
  - a) Input User Info Data
  - b) Click "Update" button
  - c) Click "Write" button

- c) Remove all default number
- d) Add 300-3FF

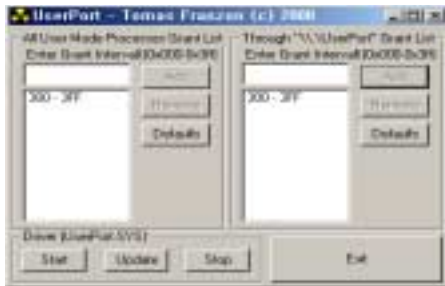

- e) Click Start button.
- f) Click Exit button.

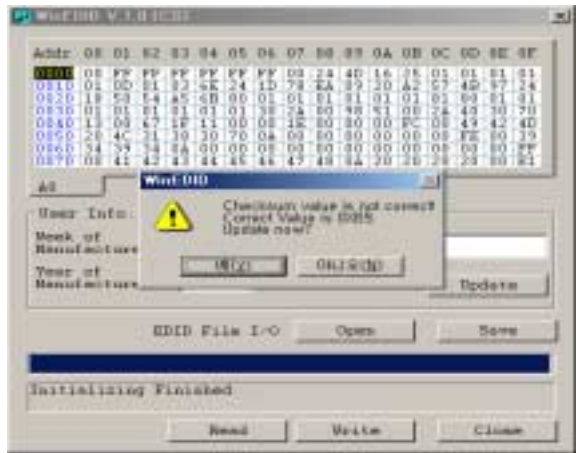

## SERVICE OSD

- 1) Turn off the power switch at the front side of the display.
- 2) Wait for about 5 seconds and press MENU, POWER switch with 1 second interval.
- 3) The SVC OSD menu contains additional menus that the User OSD menu as described below.
  - a) Auto Color : W/B balance and Automatically sets the gain and offset value.
  - b) NVRAM INIT : EEPROM initialize.(24C08)
  - c) CLEAR ETI : To initialize using time.
  - d) AGING : Select Aging mode(on/off).
  - e) R/G/B-9300K : Allows you to set the R/G/B-9300K value manually.
  - f) R/G/B-6500K : Allows you to set the R/G/B-6500K value manually.
  - g) R/G/B-Offset : Allows you to set the R/G/B-Offset value manually.(Analog Only)
  - h) R/G/B-Gain : Allows you to set the the R/G/B-Gain value manually.(Analog Only)
  - i) MODULE : To select applied module.

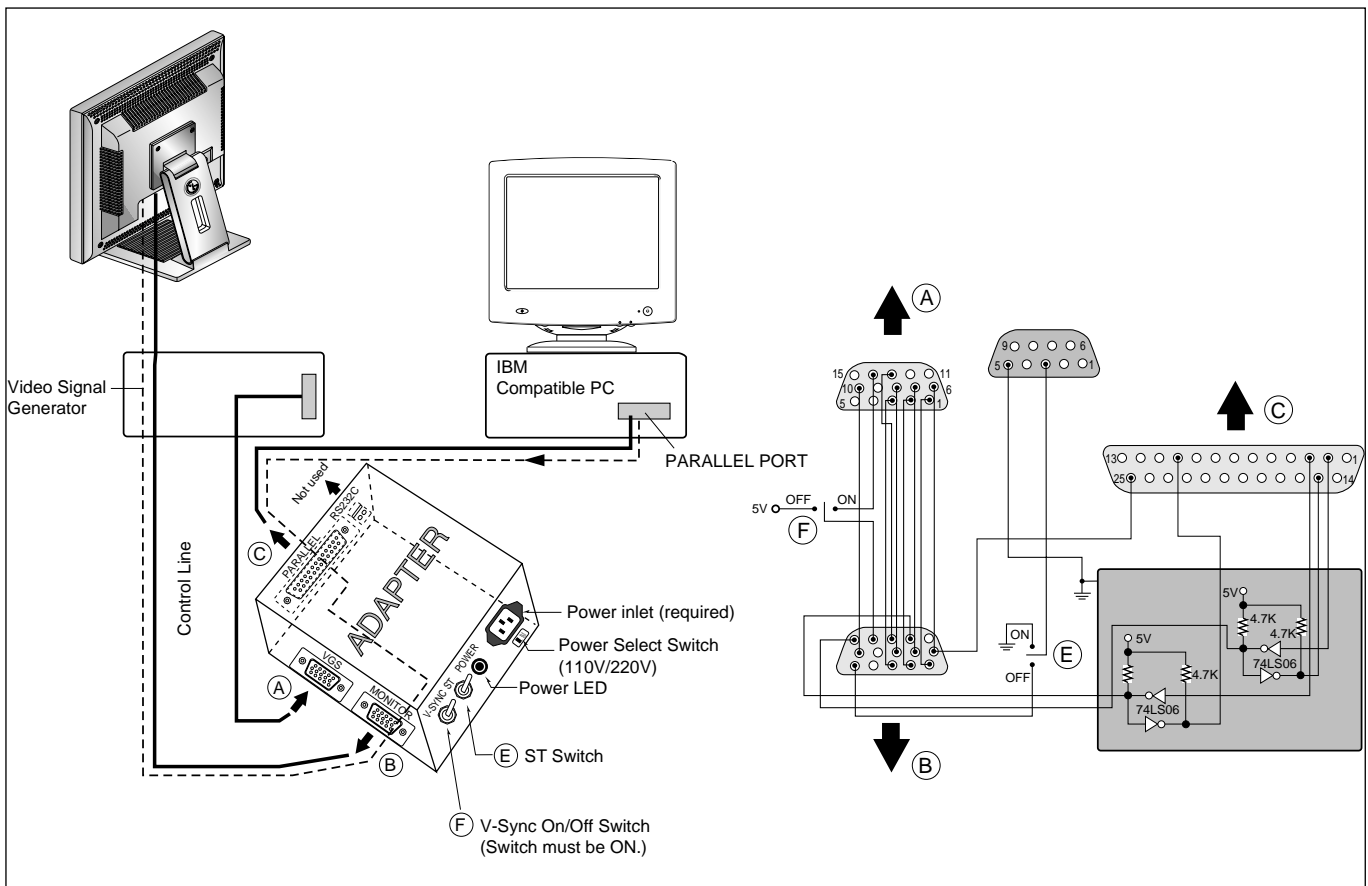

**Figure 1. Cable Connection**

# TROUBLESHOOTING GUIDE

## 1. NO POWER

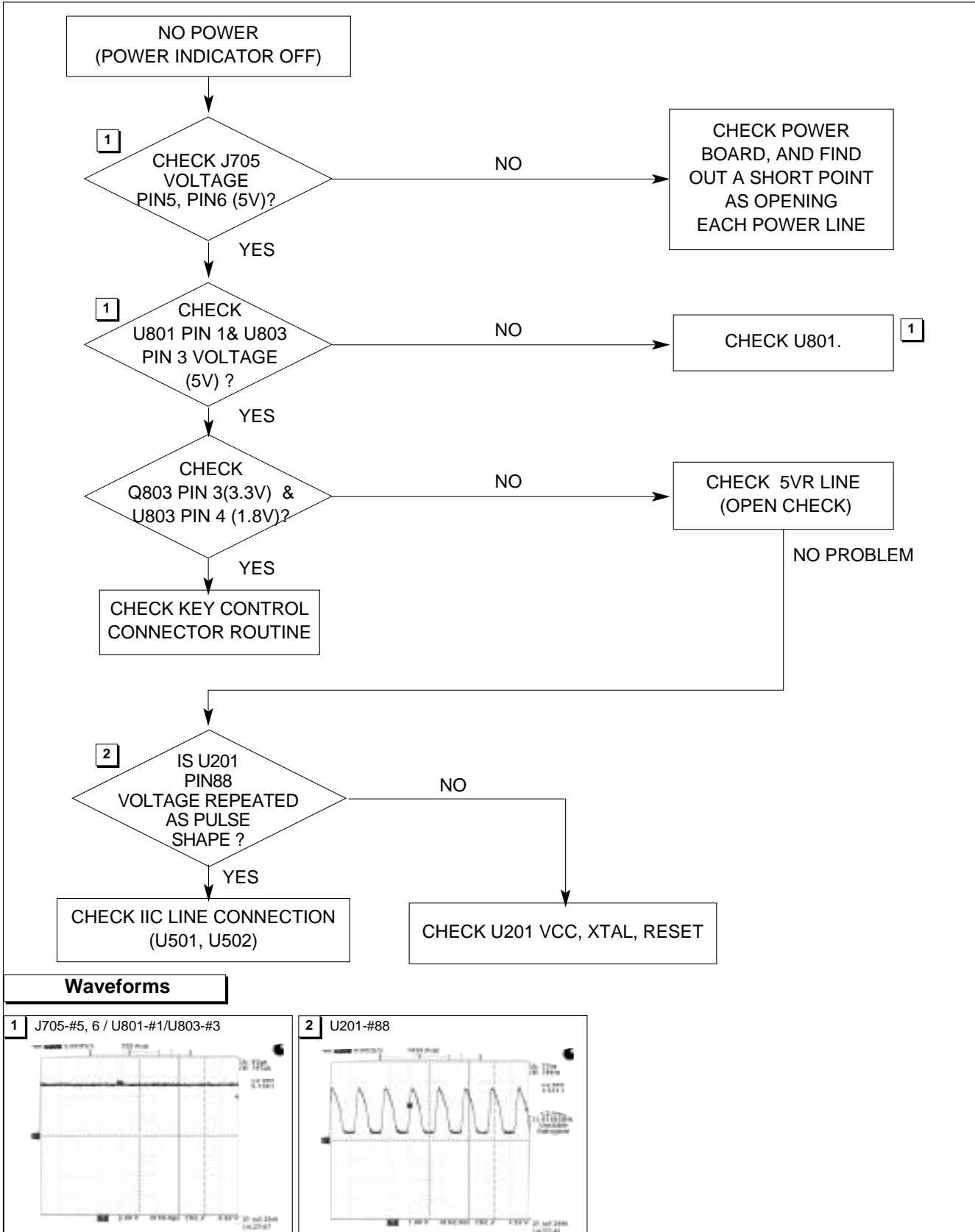

## 2. NO RASTER (OSD IS NOT DISPLAYED) – LIPS

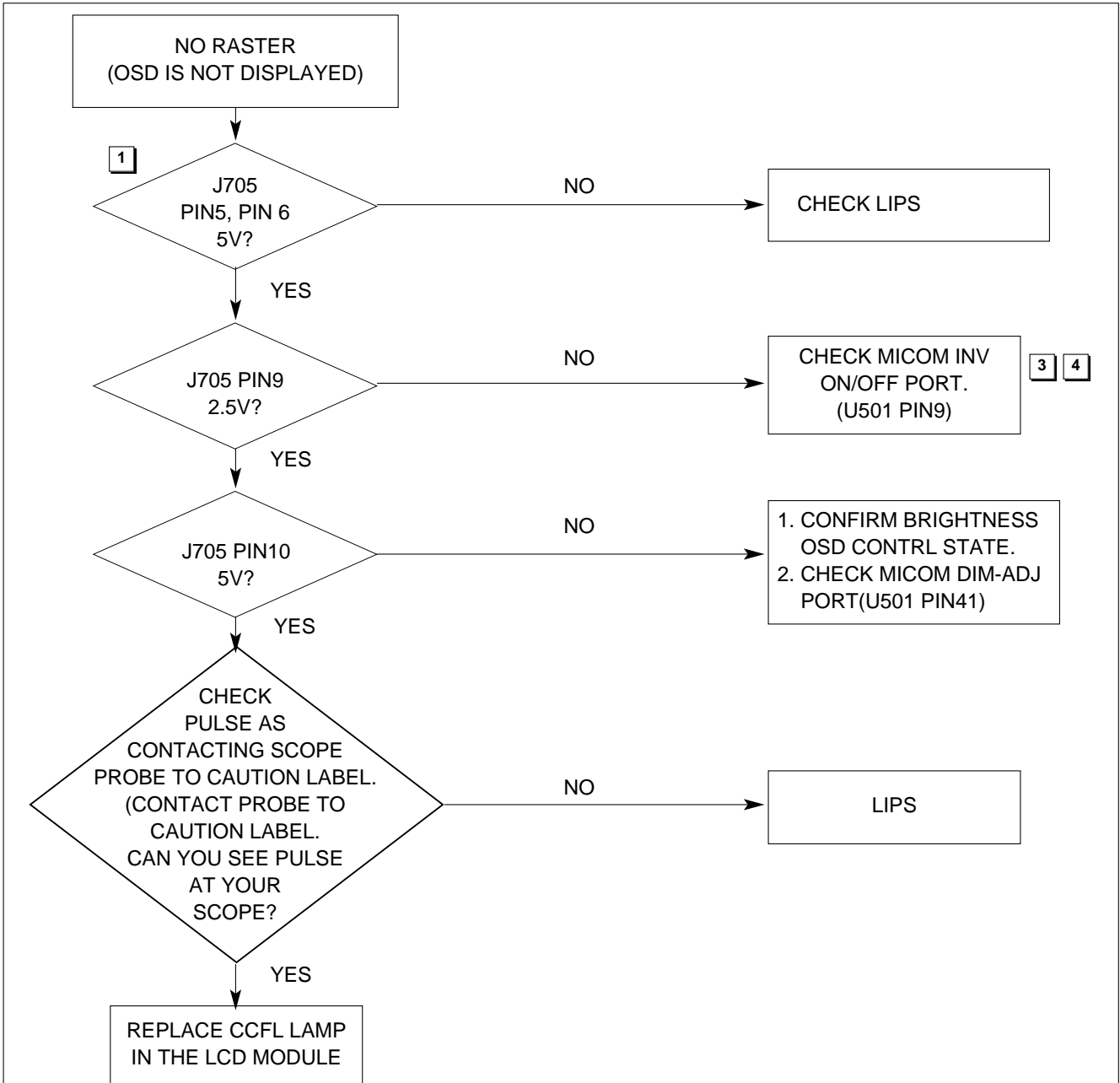

### Waveforms

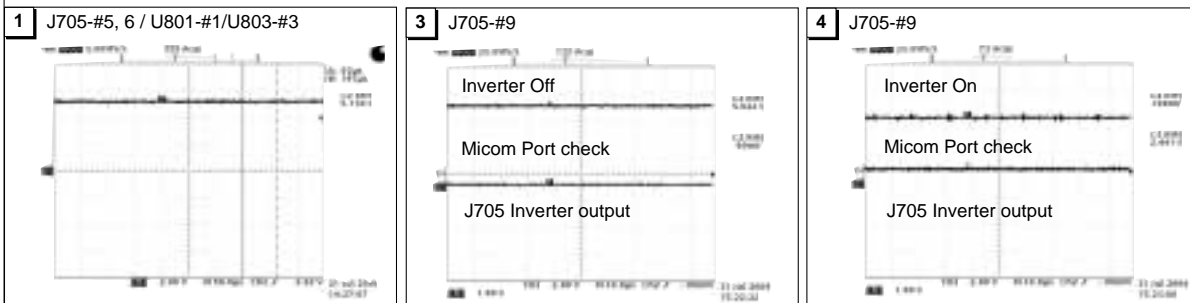

### 3. NO RASTER (OSD IS NOT DISPLAYED) – gmZAN3SL

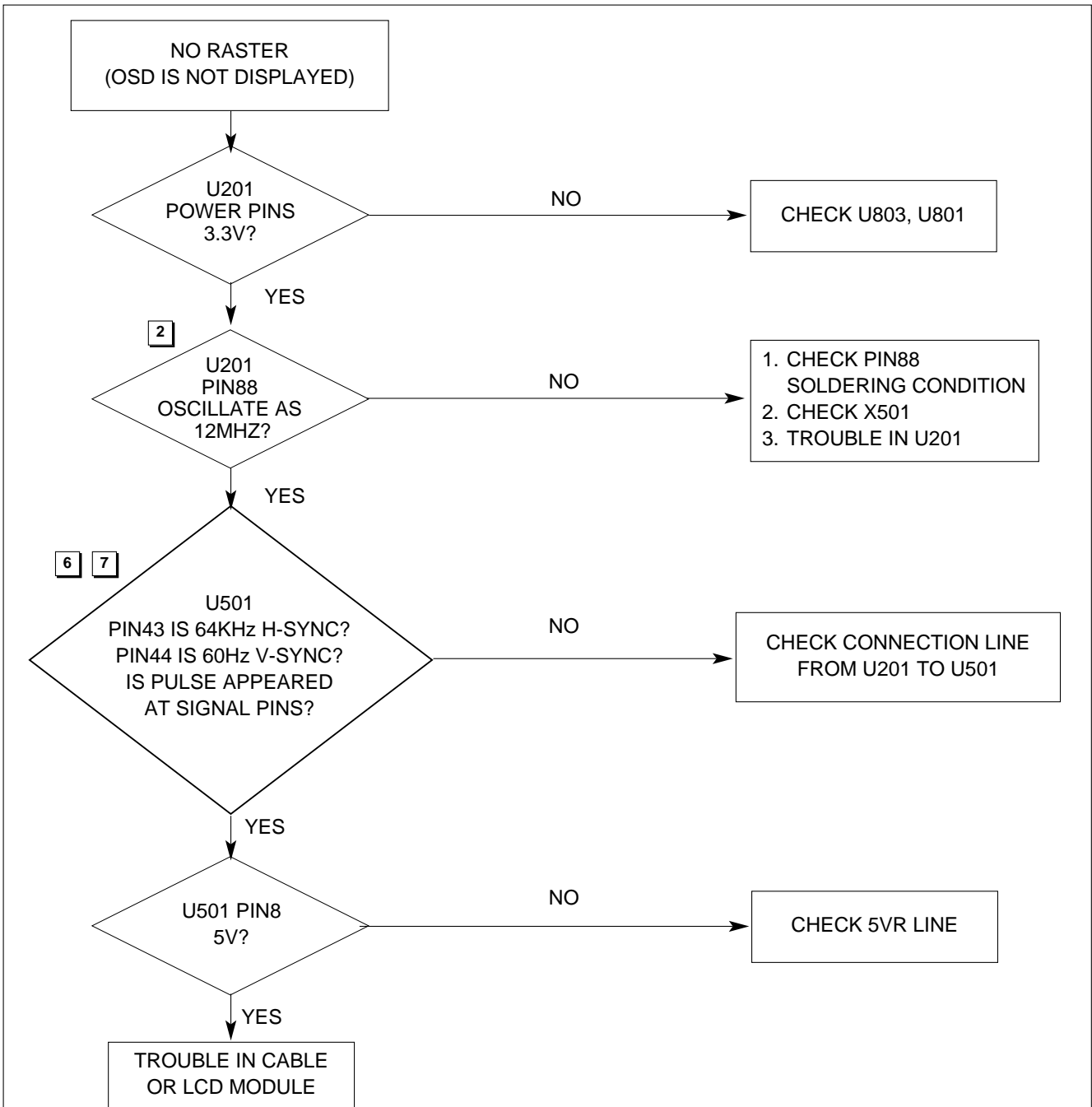

#### Waveforms

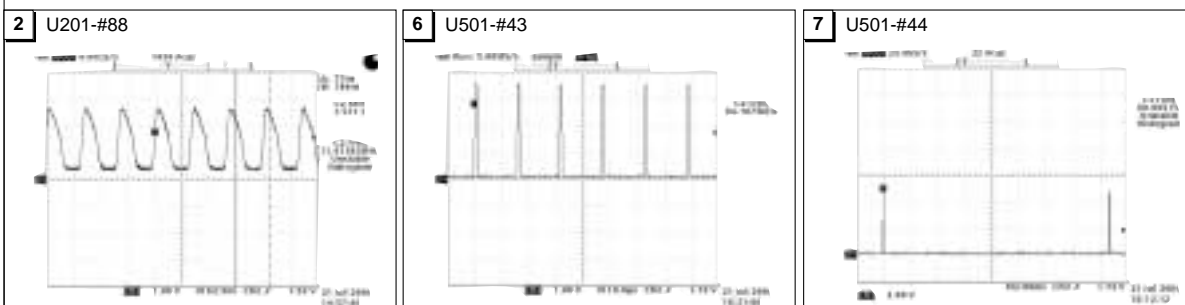



#### 4. NO RASTER (OSD IS DISPLAYED) – gmZAN3SL

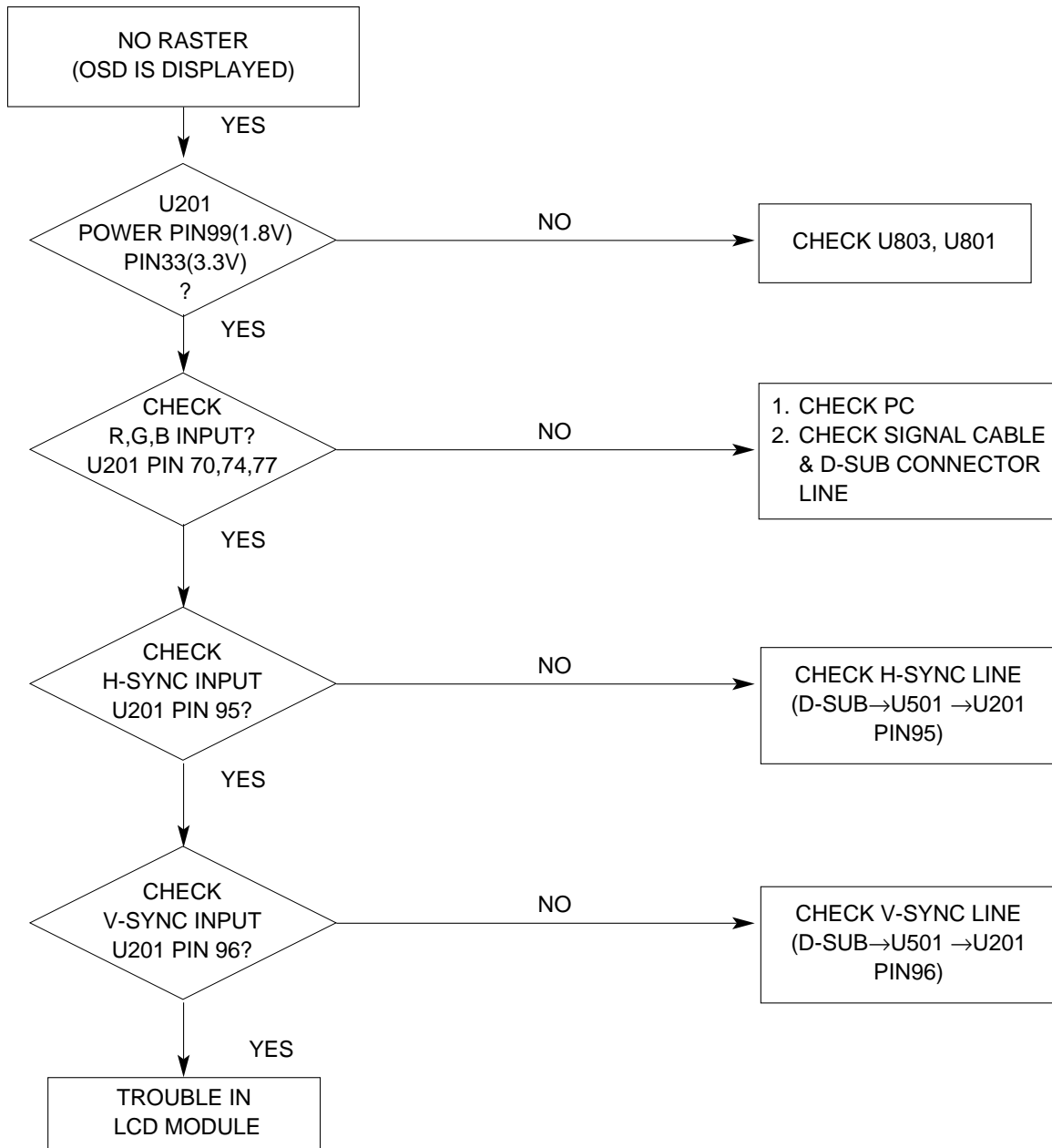

# WIRING DIAGRAM

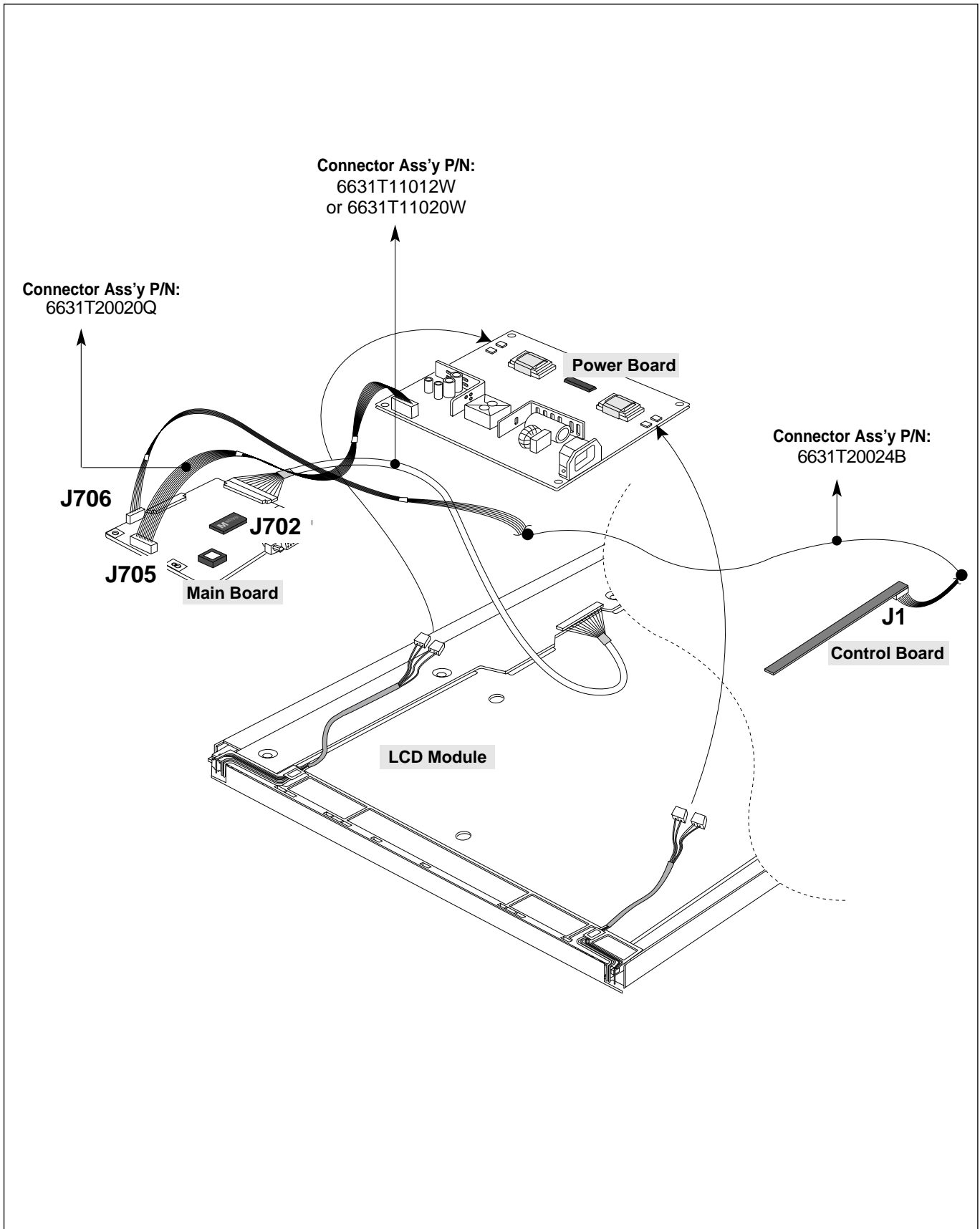

**EXPLODED VIEW**

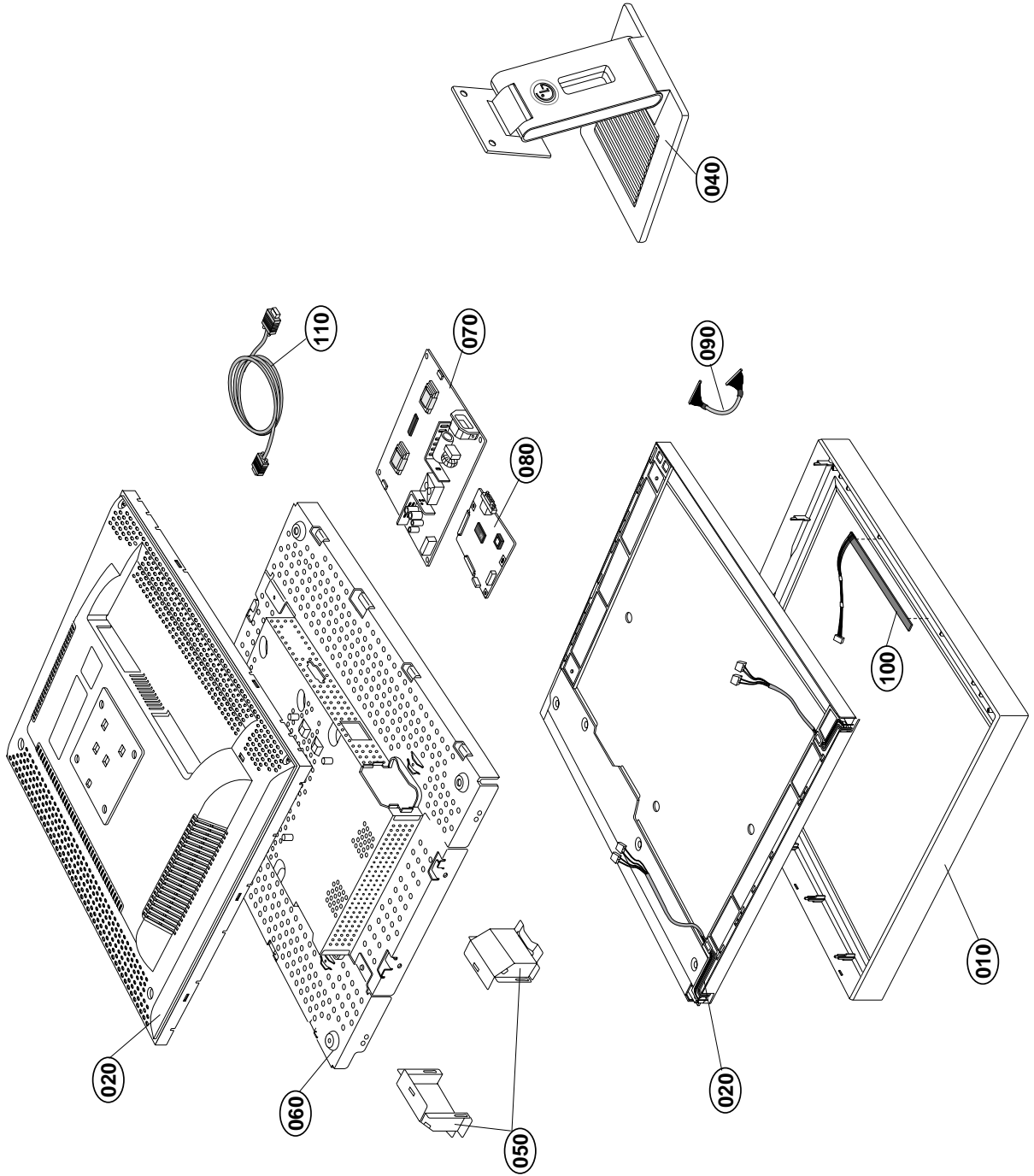

## EXPLODED VIEW PARTS LIST

Ref. No.	Part No.	Description
010	3091TKL053L	CABINET ASSEMBLY, L1710SL BRAND 3090TKL053A HF350- <b>L1710S</b>
	3091TKL117A	CABINET ASSEMBLY, L1710SM BRAND , 053, PC+ABS, <b>BK, CKD</b> OF ""080W"- <b>L1710S(K)</b>
	3091TKL080Y	CABINET ASSEMBLY, L1710BM BRAND , 053, PC+ABS, <b>GRAY, CKD</b> OF ""H" - <b>L1710S</b>
020	6304FLP110A	LCD(LIQUID CRYSTAL DISPLAY), LM170E01-A5N5 LG PHILIPS TFT COLOR LPL NJ,250NITS,SXGA,LVDS
030	3809TKL035B	BACK COVER ASSEMBLY, LB700G 3808TKL039A HF350U - <b>L1710S</b>
	3809TKL035R	BACK COVER ASSEMBLY, L1710SM , 039 PC+ABS, <b>BK(EK00), CKD</b> OF ""M""- <b>L1710S(K)</b>
	3809TKL035P	BACK COVER ASSEMBLY, L1710SM , 039, PC+ABS, <b>CKD</b> OF ""K"- <b>L1710S</b>
040	3043TKK189C	TILT SWIVEL ASSEMBLY,L1710 . LOW COST HINGE-HIPS NO USB - <b>L1710S</b>
	3043TKK189S	TILT SWIVEL ASSEMBLY, L1710S(K) , LOW COST HINGE, <b>BK, BRAND, MX LOCAL</b> - <b>L1710S(K)</b>
	3043TKK189Q	TILT SWIVEL ASSEMBLY, L1710S , LOW COST HINGE, <b>GRAY, BRAND, MX LOCAL</b> - <b>L1710S</b>
050	4814TKK231A	SHIELD, INVERTER LAMP WIRE, LB700K"
060	4951TKS102U	METAL ASSEMBLY"FRAME LPL,HD,AU(M170EG01_V1),L1710SL"
	4951TKS102W	METAL ASSEMBLY"FRAME LPL,HD,1710SL, <b>CKD</b> "
070	6871TPT271R	PWB(PCB) ASSEMBLY,POWER, M-CHASSIS 1719 SOCKET,2PIN,450V POWER TOTAL LIEN CHANG
	or 6871TPT271B	PWB(PCB) ASSEMBLY,POWER, L1710SM POWER TOTAL LIEN CHANG M-CHASSIS THE INTERGRATED LIPS FOR LPL,CMO,HD
	6871TPT282G	PWB(PCB) ASSEMBLY,POWER, M-CHASSIS 1719 SOCKET,2PIN,450V POWER TOTAL LIEN CHANG PB FREE- <b>LPL TN TYPE</b>
080	3313TL7057A	MAIN TOTAL ASSEMBLY, L1710SN GMZAN3SL - E BRAND CL-66
	3313TL7057E	MAIN TOTAL ASSEMBLY, L1710SN GMZAN3SL <b>MX CKD</b> - E BRAND CL-66
	3313TL7080A	MAIN TOTAL ASSEMBLY,L1710SN MSTAR - 10 LANGUAGE BRAND CL-66- <b>LPL TN TYPE</b>
090	6631T11020W	CONNECTOR ASSEMBLY, 30P-30P H-H 200MM UL20276AWG30 CD/PB FREE 17/19 INCH
	or 6631T11012W	CONNECTOR ASSEMBLY, 30P H-H 200MM UL20276 LG708G
100	6871TST374A	PWB(PCB) ASSEMBLY,SUB, L1710BL CONTROL TOTAL BRAND CONTROL
	6871TST374G	PWB(PCB) ASSEMBLY,SUB, L1710SM CONTROL TOTAL BRAND <b>CKD MX</b>
	6871TST811A	PWB(PCB) ASSEMBLY,SUB,L1710B CONTROL TOTAL BRAND PB FREE - <b>LPL TN TYPE</b>
110	6850TD9004J	CABLE,D-SUB, UL20276-9C(5.8MM) DT 1500MM,CORE POS400MM <b>GRAY</b> (85964) L1720BM DM
	6850TD9004G	CABLE,D-SUB, UL20276-9C(5.8MM) DT 1800MM <b>BLACK</b> (9930) SONY DM

# REPLACEMENT PARTS LIST

**CAUTION:** BEFORE REPLACING ANY OF THESE COMPONENTS,  
 READ CAREFULLY THE **SAFETY PRECAUTIONS** IN THIS MANUAL.

\* NOTE : **S** SAFETY Mark   
**AL** ALTERNATIVE PARTS

DATE: 2004. 10. 13.				
*S	*AL	LOC. NO.	PART NO.	DESCRIPTION / SPECIFICATION
<b>MAIN BOARD</b>				
<b>CAPACITORS</b>				
		C204	0CK103CK51A	0.01UF 1608 50V 10% R/TP B
		C204	0CK104CK56A	0.1UF 1608 50V 10% R/TP X7-LPL TN TYPE
		C205	0CK103CK51A	0.01UF 1608 50V 10% R/TP B
		C205	0CK104CK56A	0.1UF 1608 50V 10% R/TP X7-LPL TN TYPE
		C206	0CK103CK51A	0.01UF 1608 50V 10% R/TP B
		C206	0CK104CK56A	0.1UF 1608 50V 10% R/TP X7-LPL TN TYPE
		C207	0CK103CK51A	0.01UF 1608 50V 10% R/TP B
		C207	0CK104CK56A	0.1UF 1608 50V 10% R/TP X7-LPL TN TYPE
		C208	0CK103CK51A	0.01UF 1608 50V 10% R/TP B
		C210	0CK103CK51A	0.01UF 1608 50V 10% R/TP B
		C211	0CK103CK51A	0.01UF 1608 50V 10% R/TP B -LPL TN TYPE
		C213	0CK103CK51A	0.01UF 1608 50V 10% R/TP B
		C214	0CK103CK51A	0.01UF 1608 50V 10% R/TP B
		C215	0CK103CK51A	0.01UF 1608 50V 10% R/TP B
		C216	0CK103CK51A	0.01UF 1608 50V 10% R/TP B
		C217	0CK103CK51A	0.01UF 1608 50V 10% R/TP B
		C218	0CK103CK51A	0.01UF 1608 50V 10% R/TP B
		C219	0CK103CK51A	0.01UF 1608 50V 10% R/TP B
		C220	0CK103CK51A	0.01UF 1608 50V 10% R/TP B
		C221	0CK103CK51A	0.01UF 1608 50V 10% R/TP B
		C222	0CK103CK51A	0.01UF 1608 50V 10% R/TP B
		C223	0CK103CK51A	0.01UF 1608 50V 10% R/TP B
		C224	0CK103CK51A	0.01UF 1608 50V 10% R/TP B
		C225	0CK103CK51A	0.01UF 1608 50V 10% R/TP B
		C226	0CK103CK51A	0.01UF 1608 50V 10% R/TP B
		C227	0CK103CK51A	0.01UF 1608 50V 10% R/TP B
		C230	0CK104CK56A	0.1UF 1608 50V 10% R/TP X7 -LPL TN TYPE
		C231	0CK103CK51A	0.01UF 1608 50V 10% R/TP B
		C231	0CK104CK56A	0.1UF 1608 50V 10% R/TP X7 -LPL TN TYPE
		C232	0CK103CK51A	0.01UF 1608 50V 10% R/TP B
		C232	0CK104CK56A	0.1UF 1608 50V 10% R/TP X7 -LPL TN TYPE
		C233	0CK103CK51A	0.01UF 1608 50V 10% R/TP B
		C233	0CK104CK56A	0.1UF 1608 50V 10% R/TP X7 -LPL TN TYPE
		C234	0CK103CK51A	0.01UF 1608 50V 10% R/TP B
		C240	0CK104CK56A	0.1UF 1608 50V 10% R/TP X7 -LPL TN TYPE
		C251	0CK103CK51A	0.01UF 1608 50V 10% R/TP B -LPL TN TYPE
		C503	0CK103CK51A	0.01UF 1608 50V 10% R/TP B
		C504	0CE106CK610	"10UF SHL,SD 50V 20% BULK F"
		C504	0CH8106F611	10UF 16V M 85STD(CYL) R/TP -LPL TN TYPE
		C506	0CC030CK01A	3PF 1608 50V 0.25 PF R/TP
		C507	0CC180CK41A	18PF 1608 50V 5% R/TP NP0
		C508	0CK103CK51A	0.01UF 1608 50V 10% R/TP B
		C701	0CK105CD56A	1UF 1608 10V 10% R/TP X7R
		C707	0CC680CK41A	68PF 1608 50V 5% R/TP NP0 -LPL TN TYPE
		C708	0CK103CK51A	0.01UF 1608 50V 10% R/TP B
		C709	0CK103CK51A	0.01UF 1608 50V 10% R/TP B
		C717	0CC101CK41A	100PF 1608 50V 5% R/TP NP0
		C718	0CC101CK41A	100PF 1608 50V 5% R/TP NP0
		C720	0CC680CK41A	68PF 1608 50V 5% R/TP NP0
		C721	0CC680CK41A	68PF 1608 50V 5% R/TP NP0
		C727	0CK105CD56A	1UF 1608 10V 10% R/TP X7R
		C732	0CK103CK51A	0.01UF 1608 50V 10% R/TP B

DATE: 2004. 10. 13.				
*S	*AL	LOC. NO.	PART NO.	DESCRIPTION / SPECIFICATION
		C733	0CK104CK56A	0.1UF 1608 50V 10% R/TP X7
		C734	0CK104CK56A	0.1UF 1608 50V 10% R/TP X7
		C735	0CK104CK56A	0.1UF 1608 50V 10% R/TP X7
		C744	0CC680CK41A	68PF 1608 50V 5% R/TP NP0 -LPL TN TYPE
		C801	0CK103CK51A	0.01UF 1608 50V 10% R/TP B
		C803	0CK104CK56A	0.1UF 1608 50V 10% R/TP X7
		C803	0CE107EF610	100UF KMG,RD 16V 20% FL BU -LPL TN TYPE
		C805	0CK104CK56A	0.1UF 1608 50V 10% R/TP X7 -LPL TN TYPE
		C809	0CK103CK51A	0.01UF 1608 50V 10% R/TP B -LPL TN TYPE
		C812	0CE107EF610	100UF KMG,RD 16V 20% FL BU -LPL TN TYPE
		C814	0CE107EF610	100UF KMG,RD 16V 20% FL BU -LPL TN TYPE
		C819	0CK103CK51A	0.01UF 1608 50V 10% R/TP B -LPL TN TYPE
		C819	0CK105CD56A	1UF 1608 10V 10% R/TP X7R-LPL TN TYPE
		C820	0CE107EF610	"100UF KMG,RD 16V 20% FL BU"
		C821	0CK103CK51A	0.01UF 1608 50V 10% R/TP B
		C829	0CK103CK51A	0.01UF 1608 50V 10% R/TP B
		C831	0CE107EF610	"100UF KMG,RD 16V 20% FL BU"
		C832	0CE107EF610	"100UF KMG,RD 16V 20% FL BU"
<b>DIODES</b>				
		D701	0DS226009AA	KDS226 TP KEC SOT-23 80V
		D701	0DSIH00018A	ENKMC2837-T112 ISAHAYA R/T -LPL TN TYPE
		D702	0DS226009AA	KDS226 TP KEC SOT-23 80V
		D702	0DSIH00018A	ENKMC2837-T112 ISAHAYA R/T -LPL TN TYPE
		D706	0DS226009AA	KDS226 TP KEC SOT-23 80V
		D706	0DSIH00018A	ENKMC2837-T112 ISAHAYA R/T -LPL TN TYPE
		ZD701	0DZKE00138A	KDZ5.6V KEC R/TP USC 0.2W
		ZD701	0DZ560009GB	BZT52C5V6S DIODES R/TP SOD -LPL TN TYPE
		ZD702	0DZKE00138A	KDZ5.6V KEC R/TP USC 0.2W
		ZD702	0DZ560009GB	BZT52C5V6S DIODES R/TP SOD -LPL TN TYPE
		ZD703	0DZKE00138A	KDZ5.6V KEC R/TP USC 0.2W
		ZD703	0DZ560009GB	BZT52C5V6S DIODES R/TP SOD -LPL TN TYPE
		ZD704	0DZKE00138A	KDZ5.6V KEC R/TP USC 0.2W
		ZD704	0DZ560009GB	BZT52C5V6S DIODES R/TP SOD -LPL TN TYPE
		ZD705	0DZKE00138A	KDZ5.6V KEC R/TP USC 0.2W
		ZD711	0DZKE00138A	KDZ5.6V KEC R/TP USC 0.2W
		ZD711	0DZ560009GB	BZT52C5V6S DIODES R/TP SOD -LPL TN TYPE
		ZD712	0DZ560009GB	BZT52C5V6S DIODES R/TP SOD -LPL TN TYPE
<b>ICs</b>				
		U201	0IPRPGN016A	GMZAN3SL-BD GENESIS 128P,P"
		U201	0IPRPM3017A	TSU16AL-LF MSTAR 100P,QFP -LPL TN TYPE
		U501	0IZZTSZ520A	L1710SN GMZAN3SL MICOM ASS
		U501	0IZZTSZ612A	L1710SN MSTAR MICOM ASSY -LPL TN TYPE
		U502	0ISG240860B	M24C08W6 SGS-THOMSON 8SOP
		U502	0ICS240813B	CAT24WC08J-TE13 8P,SOIC -LPL TN TYPE
		U801	0IPMGKE011A	KIA78D33F KEC DPAK R/TP 3.
		U803	0IPMGSG019A	LD1117S18TR STM SOT223 R/T
		Q502	0IKE704200H	KIA7042AP TO-92 TP 4.2 VO
<b>TRANSISTOR</b>				
		Q503	0TR390409AE	FAIRCHILD KST3904(LGEMTF)

DATE: 2004. 10. 13.				
*S	*AL	LOC. NO.	PART NO.	DESCRIPTION / SPECIFICATION
		Q503	OTRIH80001A	RT1C3904-T112 ISAHAYA R/TP -LPL TN TYPE
		Q504	OTR390409AE	FAIRCHILD KST3904(LGEMTF)
		Q504	OTRIH80001A	RT1C3904-T112 ISAHAYA R/TP -LPL TN TYPE
		Q505	OTR390409AE	FAIRCHILD KST3904(LGEMTF)
		Q505	OTRIH80001A	RT1C3904-T112 ISAHAYA R/TP -LPL TN TYPE
		Q703	OTR390609FA	KST3906-MTF TP SAMSUNG SO
		Q703	OTR390609DD	KEC 2N3906TA(KN3906TA) TP -LPL TN TYPE
		Q704	OTR390609FA	KST3906-MTF TP SAMSUNG SO
		Q704	OTR390609DD	KEC 2N3906TA(KN3906TA) TP -LPL TN TYPE
		Q801	OTR127309AA	KTA1273-Y(KTA966A) TP KEC -LPL TN TYPE
		Q802	OTRIH80001A	RT1C3904-T112 ISAHAYA R/TP -LPL TN TYPE
		Q803	OTR127309AA	KTA1273-Y(KTA966A) TP KEC
		Q804	OTR390409AE	FAIRCHILD KST3904(LGEMTF)
<b>RESISTORS</b>				
		R201	0RJ1000D677	100 OHM 1/10 W 5% 1608 R/T
		R201	0RJ0682D677	68 OHM 1/10 W 5% 1608 R/TP -LPL TN TYPE
		R202	0RJ1000D677	100 OHM 1/10 W 5% 1608 R/T
		R202	0RJ0682D677	68 OHM 1/10 W 5% 1608 R/TP -LPL TN TYPE
		R203	0RJ1000D677	100 OHM 1/10 W 5% 1608 R/T
		R203	0RJ0682D677	68 OHM 1/10 W 5% 1608 R/TP -LPL TN TYPE
		R207	0RJ3900D677	390 OHM 1/10 W 5% 1608 R/T -LPL TN TYPE
		R208	0RJ1200D677	120 OHM 1/10 W 5% 1608 R/T
		R208	0RJ0682D677	68 OHM 1/10 W 5% 1608 R/TP -LPL TN TYPE
		R209	0RJ1200D677	120 OHM 1/10 W 5% 1608 R/T
		R209	0RJ0682D677	68 OHM 1/10 W 5% 1608 R/TP -LPL TN TYPE
		R210	0RJ1200D677	120 OHM 1/10 W 5% 1608 R/T
		R210	0RJ0682D677	68 OHM 1/10 W 5% 1608 R/TP -LPL TN TYPE
		R211	0RJ1000D677	100 OHM 1/10 W 5% 1608 R/T
		R213	0RJ0000D677	0 OHM 1/10 W 5% 1608 R/TP
		R214	0RJ0000D677	0 OHM 1/10 W 5% 1608 R/TP
		R216	0RJ0000D677	0 OHM 1/10 W 5% 1608 R/TP-LPL TN TYPE
		R217	0RJ0000D677	0 OHM 1/10 W 5% 1608 R/TP-LPL TN TYPE
		R220	0RJ0000D677	0 OHM 1/10 W 5% 1608 R/TP
		R220	0RJ4701D677	4.7K OHM 1/10 W 5% 1608 -LPL TN TYPE
		R221	0RJ0000D677	0 OHM 1/10 W 5% 1608 R/TP
		R222	0RJ1004D677	1000000 OHM 1/10 W 5% 1608
		R240	0RJ1001D677	1K OHM 1/10 W 5% 1608 R/TP -LPL TN TYPE
		R501	0RJ4701D677	4.7K OHM 1/10 W 5% 1608 -LPL TN TYPE
		R503	0RJ4701D677	4.7K OHM 1/10 W 5% 1608 -LPL TN TYPE
		R506	0RJ4701D677	4.7K OHM 1/10 W 5% 1608 R/
		R508	0RJ4701D677	4.7K OHM 1/10 W 5% 1608 R/
		R514	0RJ4701D677	4.7K OHM 1/10 W 5% 1608 R/
		R515	0RJ4701D677	4.7K OHM 1/10 W 5% 1608 R/
		R516	0RJ4701D677	4.7K OHM 1/10 W 5% 1608 R/
		R518	0RJ4701D677	4.7K OHM 1/10 W 5% 1608 R/
		R520	0RJ4701D677	4.7K OHM 1/10 W 5% 1608 R/
		R521	0RJ4701D677	4.7K OHM 1/10 W 5% 1608 R/
		R522	0RJ4701D677	4.7K OHM 1/10 W 5% 1608 R/
		R523	0RJ4701D677	4.7K OHM 1/10 W 5% 1608 R/
		R530	0RJ1002D677	10K OHM 1/10 W 5% 1608 R/T-LPL TN TYPE
		R534	0RJ0000D677	0 OHM 1/10 W 5% 1608 R/TP
		R535	0RJ3301D677	3.3K OHM 1/10 W 5% 1608 R/
		R537	0RJ3301D677	3.3K OHM 1/10 W 5% 1608 R/
		R541	0RJ1000D677	100 OHM 1/10 W 5% 1608 R/T
		R542	0RJ1000D677	100 OHM 1/10 W 5% 1608 R/T
		R543	0RJ4701D677	4.7K OHM 1/10 W 5% 1608 R/
		R544	0RJ4701D677	4.7K OHM 1/10 W 5% 1608 R/
		R545	0RJ4700D677	470 OHM 1/10 W 5% 1608 R/T
		R547	0RJ4700D677	470 OHM 1/10 W 5% 1608 R/T
		R548	0RJ0332D677	33 OHM 1/10 W 5% 1608 R/TP
		R549	0RJ0332D677	33 OHM 1/10 W 5% 1608 R/TP

DATE: 2004. 10. 13.				
*S	*AL	LOC. NO.	PART NO.	DESCRIPTION / SPECIFICATION
		R555	0RJ1000D677	100 OHM 1/10 W 5% 1608 R/T
		R557	0RJ1000D677	100 OHM 1/10 W 5% 1608 R/T
		R560	0RJ1501D677	1.5K OHM 1/10 W 5% 1608 R/
		R561	0RJ4701D677	4.7K OHM 1/10 W 5% 1608 R/
		R566	0RJ1002D677	10K OHM 1/10 W 5% 1608 R/T
		R701	0RJ0752D677	75 OHM 1/10 W 5% 1608 R/TP
		R702	0RJ2001D677	2K OHM 1/10 W 5% 1608 R/TP-LPL TN TYPE
		R703	0RJ0752D677	75 OHM 1/10 W 5% 1608 R/TP
		R704	0RJ2001D677	2K OHM 1/10 W 5% 1608 R/TP-LPL TN TYPE
		R706	0RJ0752D677	75 OHM 1/10 W 5% 1608 R/TP
		R708	0RJ4700D677	470 OHM 1/10 W 5% 1608 R/T
		R709	0RJ1001D677	1K OHM 1/10 W 5% 1608 R/TP
		R709	0RJ4700D677	470 OHM 1/10 W 5% 1608 R/T-LPL TN TYPE
		R712	0RJ0102D677	10 OHM 1/10 W 5% 1608 R/TP-LPL TN TYPE
		R716	0RJ4701D677	4.7K OHM 1/10 W 5% 1608 R/
		R717	0RJ4701D677	4.7K OHM 1/10 W 5% 1608 R/
		R720	0RJ0000D677	0 OHM 1/10 W 5% 1608 R/TP
		R721	0RJ4700D677	470 OHM 1/10 W 5% 1608 R/T
		R722	0RJ1000D677	100 OHM 1/10 W 5% 1608 R/T
		R723	0RJ0682D677	68 OHM 1/10 W 5% 1608 R/TP
		R723	0RJ0332D677	33 OHM 1/10 W 5% 1608 R/TP-LPL TN TYPE
		R724	0RJ0682D677	68 OHM 1/10 W 5% 1608 R/TP
		R724	0RJ0332D677	33 OHM 1/10 W 5% 1608 R/TP-LPL TN TYPE
		R726	0RJ1002D677	10K OHM 1/10 W 5% 1608 R/T
		R727	0RJ1002D677	10K OHM 1/10 W 5% 1608 R/T
		R737	0RJ0000D677	0 OHM 1/10 W 5% 1608 R/TP
		R744	0RJ4701D677	4.7K OHM 1/10 W 5% 1608 R/
		R747	0RJ4701D677	4.7K OHM 1/10 W 5% 1608 R/
		R751	0RJ4700D677	470 OHM 1/10 W 5% 1608 R/T -LPL TN TYPE
		R752	0RJ1000D677	100 OHM 1/10 W 5% 1608 R/T -LPL TN TYPE
		R753	0RJ1000D677	100 OHM 1/10 W 5% 1608 R/T -LPL TN TYPE
		R754	0RJ1000D677	100 OHM 1/10 W 5% 1608 R/T -LPL TN TYPE
		R755	0RJ1000D677	100 OHM 1/10 W 5% 1608 R/T -LPL TN TYPE
		R769	0RJ0000D677	0 OHM 1/10 W 5% 1608 R/TP
		R775	0RJ0682D677	68 OHM 1/10 W 5% 1608 R/TP
		R778	0RJ0682D677	68 OHM 1/10 W 5% 1608 R/TP-LPL TN TYPE
		R779	0RJ0682D677	68 OHM 1/10 W 5% 1608 R/TP
		R780	0RJ2001D677	2K OHM 1/10 W 5% 1608 R/TP
		R781	0RJ2001D677	2K OHM 1/10 W 5% 1608 R/TP
		R781	0RJ0682D677	68 OHM 1/10 W 5% 1608 R/TP-LPL TN TYPE
		R782	0RJ0471D677	4.7 OHM 1/10 W 5% 1608 R/T
		R803	0RJ0000D677	0 OHM 1/10 W 5% 1608 R/TP
		R803	0RH0000D622	0 OHM 1 / 10 W 2012 5.00%-LPL TN TYPE
		R804	0RJ1002D677	10K OHM 1/10 W 5% 1608 R/T-LPL TN TYPE
		R805	0RJ1002D677	10K OHM 1/10 W 5% 1608 R/T
		R805	0RH2000D622	200 OHM 1 / 10 W 5% D R/TP-LPL TN TYPE
		R806	0RJ3900D677	390 OHM 1/10 W 5% 1608 R/T
		R806	0RH2000D622	200 OHM 1 / 10 W 5% D R/TP-LPL TN TYPE
		R807	0RJ3900D677	390 OHM 1/10 W 5% 1608 R/T
		R808	0RJ0000D677	0 OHM 1/10 W 5% 1608 R/TP-LPL TN TYPE
		R809	0RJ3900D677	390 OHM 1/10 W 5% 1608 R/T
		R810	0RJ3900D677	390 OHM 1/10 W 5% 1608 R/T
		R813	0RJ0472D677	47 OHM 1/10 W 5% 1608 R/TP
		R814	0RJ0472D677	47 OHM 1/10 W 5% 1608 R/TP
		R815	0RJ0472D677	47 OHM 1/10 W 5% 1608 R/TP
		R816	0RJ0472D677	47 OHM 1/10 W 5% 1608 R/TP
		R816	0RJ1002D677	10K OHM 1/10 W 5% 1608 R/T-LPL TN TYPE
		R817	0RJ0472D677	47 OHM 1/10 W 5% 1608 R/TP
		R818	0RJ0472D677	47 OHM 1/10 W 5% 1608 R/TP
		R819	0RJ0472D677	47 OHM 1/10 W 5% 1608 R/TP
		R820	0RJ0472D677	47 OHM 1/10 W 5% 1608 R/TP
		R820	0RJ0000D677	0 OHM 1/10 W 5% 1608 R/TP-LPL TN TYPE
		R821	0RJ0472D677	47 OHM 1/10 W 5% 1608 R/TP







# # 2 L1515/L1715 MICOM

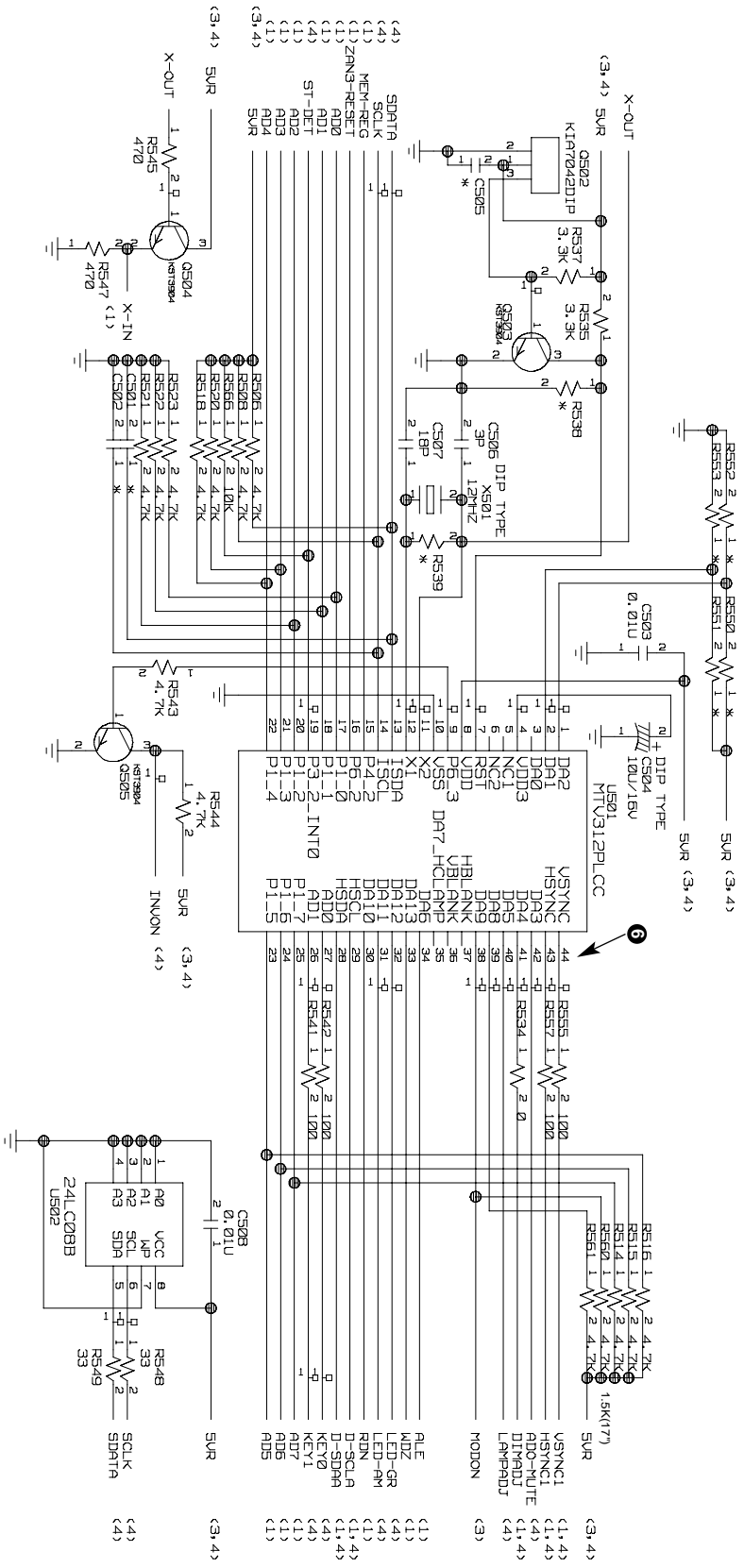

6 U501-#43, 44

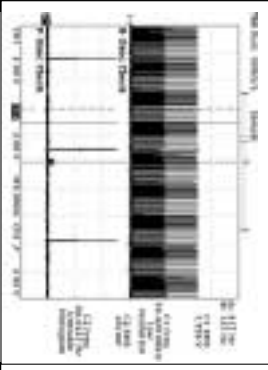



## 4. CONNECTOR & JACKS

# # 4 CONNECTOR & JACKS

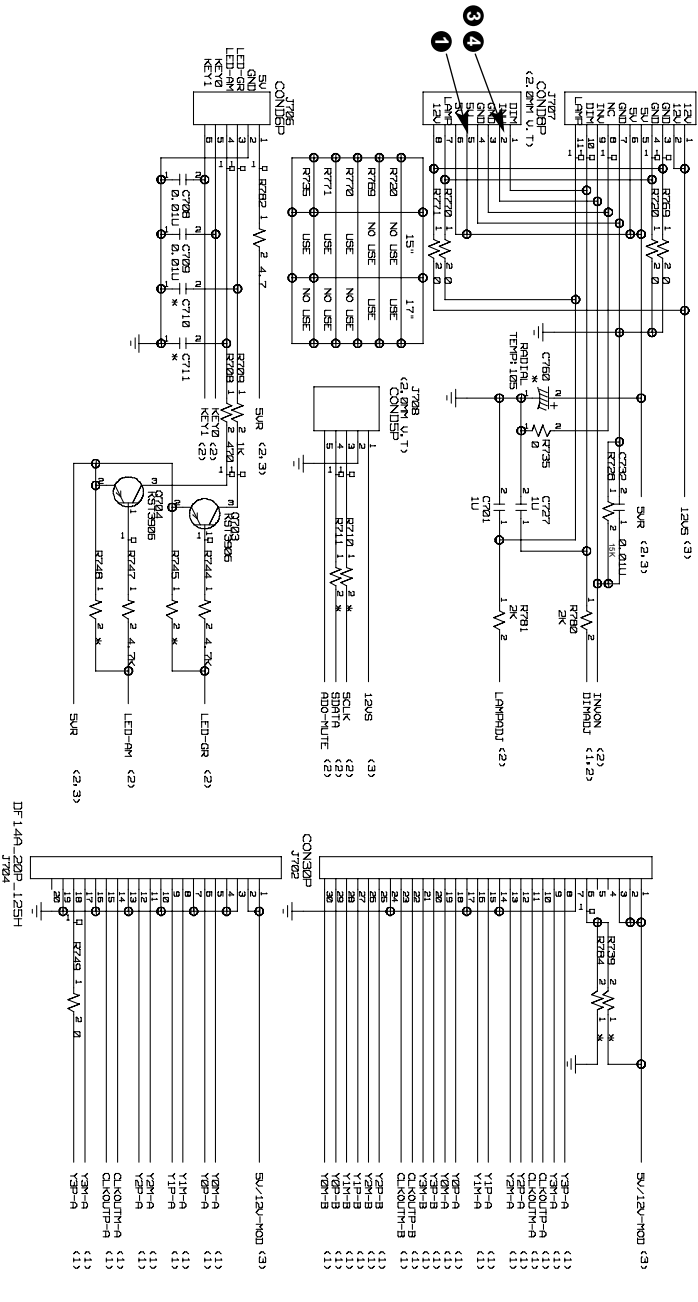
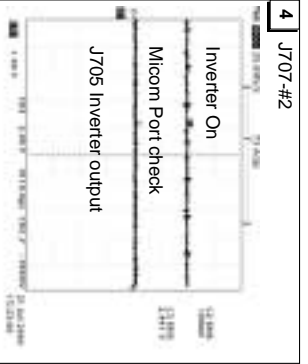
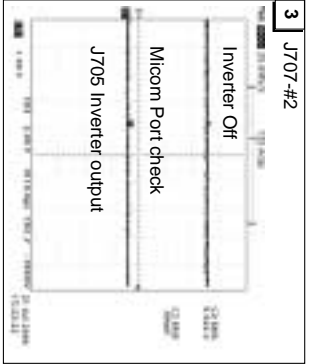
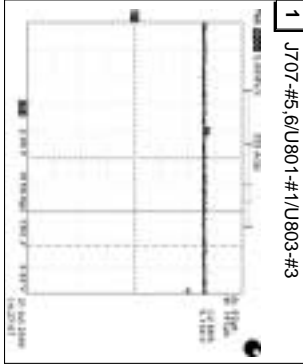
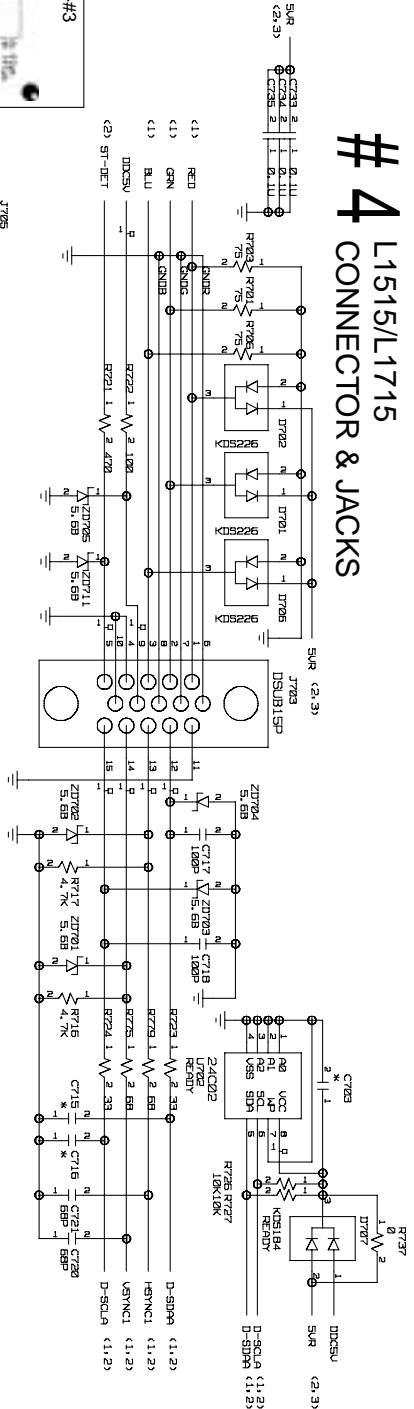



P/NO : 3828TSL097V

Oct. 2004  
Printed in Korea