

## LT8365

# Low IQ Boost/SEPIC/Inverting Regulator With 150V, 1.5A Switch

## DESCRIPTION

Demonstration circuit 2840A features the [LT<sup>®</sup>8365](#) in a Boost inverting configuration. It operates with a switching frequency of 400kHz and is designed to convert a 9V to 30V source to -250V, with 10mA output current.

The demo board contains an optional third charge pump stage for applications requiring higher output voltages. If needed, remove R14 and install optional components. Output voltage sensing connections remain the same.

The LT8365 can be used for different topologies with input voltages up to 60V. However, component selection in this demo circuit restrict the input voltage to 30V.

The demo board contains a selectable jumper, JP1, to aid in the selection of the desired Sync pin mode of operation. The default setting is Burst Mode<sup>®</sup> operation.

This layout is optimized for good EMI performance and small solution size. Input and output filters are necessary for CISPR 25 Class 5 emissions. Radiated emissions plots are included in this manual.

The data sheet gives a complete description of the device, operation and application information. The data sheet must be read in conjunction with this demo manual.

[Design files for this circuit board are available.](#)

All registered trademarks and trademarks are the property of their respective owners.

## PERFORMANCE SUMMARY Specifications are at T<sub>A</sub> = 25°C

SYMBOL	PARAMETER	CONDITIONS	MIN	TYP	MAX	UNITS
V <sub>IN</sub>	Input Supply Range		9		30	V
V <sub>OUT</sub>	Output Voltage Range	V <sub>IN</sub> = 12V, I <sub>LOAD</sub> = 10mA	-245	-250	-255	V
RIPPLE		V <sub>IN</sub> = 12V, I <sub>LOAD</sub> = 10mA		1		V
EFFICIENCY		V <sub>IN</sub> = 12V, I <sub>LOAD</sub> = 10mA		80		%
LOAD CURRENT	Max Load Current	V <sub>IN</sub> = 9V			10	mA
SWITCHING FREQUENCY				400		kHz

## QUICK START PROCEDURE

Demo circuit 2840A is easy to set up to evaluate the performance of the LT8365. Refer to Figure 1 for proper measurement equipment setup and follow the procedure below:

NOTE. When measuring the input or output voltage ripple, care must be taken to avoid a long ground lead on the oscilloscope probe. Measure the input or output voltage ripple by touching the probe tip directly across the  $V_{IN}$  or  $V_{OUT}$  and GND terminals. See Figure 2 for proper scope probe technique.

1. With power off, connect the input power supply to  $V_{IN}$  and GND.

2. Turn on the power at the input.

NOTE. Make sure that the input voltage does not exceed 30V.

3. Check for the proper output voltage.

If there is no output, temporarily disconnect the load to make sure the load is not set too high.

NOTE.

4. Once the proper output voltages are established, adjust the load within the operating range and observe the output voltage regulation, ripple voltage, efficiency and other parameters.

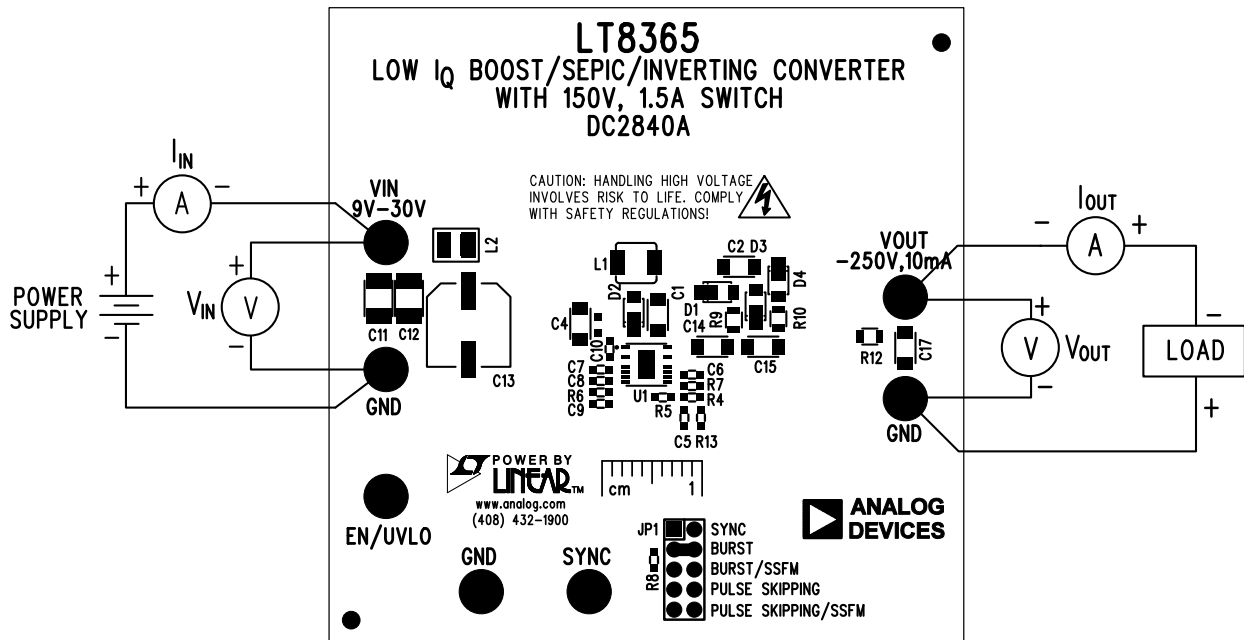

Figure 1. DC2840A Proper Equipment Setup

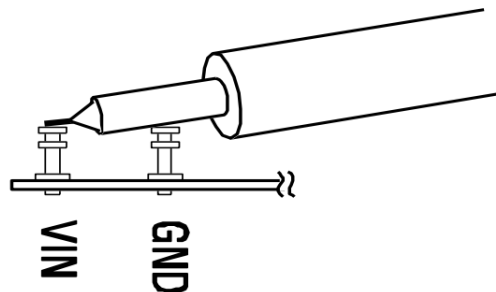
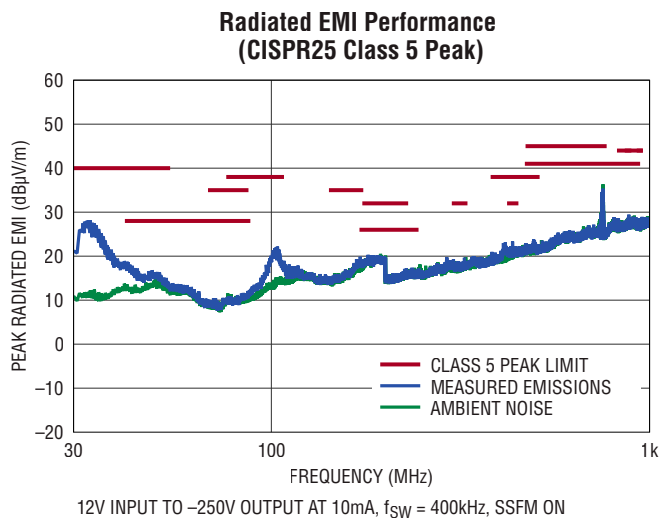
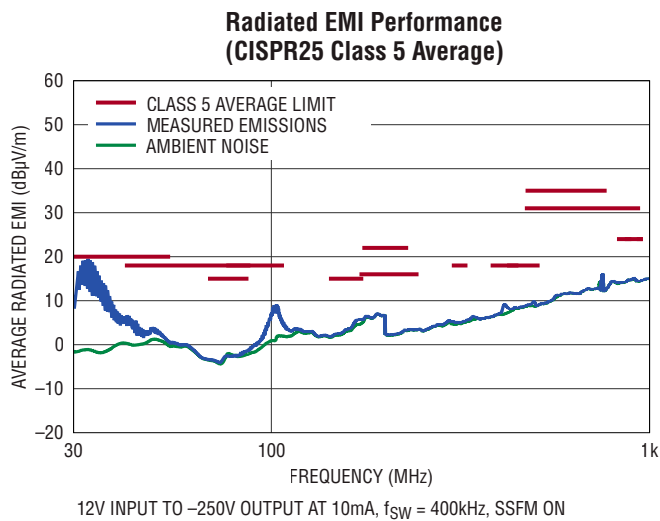

Figure 2. Measuring Input or Output Ripple

**QUICK START PROCEDURE**



**Figure 3. CISPR25 Radiated Emissions Test, Peak Detection**



**Figure 4. CISPR25 Radiated Emissions Test, Average Detection**

# DEMO MANUAL DC2840A

## PARTS LIST

ITEM	QTY	REFERENCE	PART DESCRIPTION	MANUFACTURER/PART NUMBER
<b>Required Circuit Components</b>				
1	2	R4, R13	RES., 499k OHMS, 1%, 1/10W, 0603, AEC-Q200	NIC, NRC06F4993TRF
2	1	R14	RES., 0 OHM, 1/4W, 1206, AEC-Q200	NIC, NRC12Z0TRF
3	1	R1	RES., 1M OHM, 1%, 1/10W, 0603, AEC-Q200	NIC, NRC06F1004TRF
4	1	R8	RES., 100k OHMS, 1%, 1/10W, 0603, AEC-Q200	NIC, NRC06F1003TRF
5	1	R5	RES., 3.24k OHMS, 1%, 1/10W, 0603, AEC-Q200	NIC, NRC06F3241TRF
6	1	R3	RES., 287k OHMS, 1%, 1/10W, 0603, AEC-Q200	PANASONIC, ERJ3EKF2873V
7	1	R7	RES., 107k OHMS, 1%, 1/10W, 0603	NIC, NRC06F1073TRF
8	1	R12	RES., 47 OHMS, 5%, 1/8W, 0805, AEC-Q200	CRCW080547R0JNEA
9	1	R6	RES., 84.5k OHMS, 1%, 1/10W, 0603, AEC-Q200	NIC, NRC06F8452TRF
10	2	R9, R10	RES., 20 OHMS, 5%, 1/8W, 0805	NIC, NRC10J200TRF
11	1	C7	CAP, 1uF, X5R, 25V, 10%, 0603	AVX, 06033D105KAT2A
12	1	C6	CAP, 0.22uF, X7R, 25V, 10%, 0603	MURATA, GRM188R71E224KA88D
13	1	C4	CAP, 10uF, X5R, 50V, 10%, 1206	MURATA, GRM31CR61H106KA12L
14	1	C9	CAP, 1000pF, C0G, 100V, 5%, 0603, AEC-Q200	KEMET, C0603C102J1GCAUTO
15	2	C1, C2	CAP, 0.1uF, X7R, 200V, 10%, 1206	12062C104KAT2A
16	1	C13	CAP, 68uF, ALUM. ELECT., 50V, 20%, 8x10.2mm SMD	EEHZC1H680P
17	2	C14, C15	CAP, 0.22uF, X7T, 200V, 10%, 1206, AEC-Q200	CGJ5L3X7T2D224K160AA
18	1	C17	CAP, 1000pF, X7R, 500V, 10%, 1206	C1206C102KCRCTU
19	2	C11, C12	CAP, 4.7uF, X7R, 50V, 10%, 1210	AVX, 12105C475KAT2A
20	1	C10	CAP, 1uF, X5R, 50V, 10%, 0603	GRM188R61H105KAALD
21	1	L1	IND., 10uH, PWR., 20%, 1.5A, 4020	74437324100
22	1	L2	IND., 0.47uH, PWR., 20%, 2.1A, 0806	74479876147
23	4	D1, D2, D3, D4	DIODE, SCHOTTKY, 150V, 1A, PowerDI123	DFLS1150-7
24	1	U1	IC, BOOST/SEPIC/INVERTG CONVERTER, MSOP-16	LT8365MSE#PBFLT8365MSE#TRPBF
<b>Additional Demo Board Circuit Components</b>				
1	1	R2	RES., 0 OHM, 1/10W, 0603, AEC-Q200	NIC, NRC06Z0TRF
2	0	R11	RES., OPTION, 0805	
3	0	C5, C8	CAP, OPTION, 0603	
4	0	C3, C16	CAP, OPTION, 1206	
5	0	D5, D6	DIODE, OPTION, SCHOTTKY, PowerDI-123	
<b>Hardware: For Demo Board Only</b>				
1	1	XJP1	CONN., SHUNT, FEMALE, 2 POS, 2mm	WURTH, 60800213421
2	1	JP1	CONN., HDR, MALE, 2x5, 2mm, STR, THT	WURTH, 62001021121
3	7	E1, E2, E3, E4, E5, E6, E7	TEST POINT, TURRET, 0.094 MTG. HOLE, PCB 0.062 THICK	MILL-MAX, 2501-2-00-80-00-00-07-0

**SCHEMATIC DIAGRAM**

WARNING: SHOCK HAZARD!

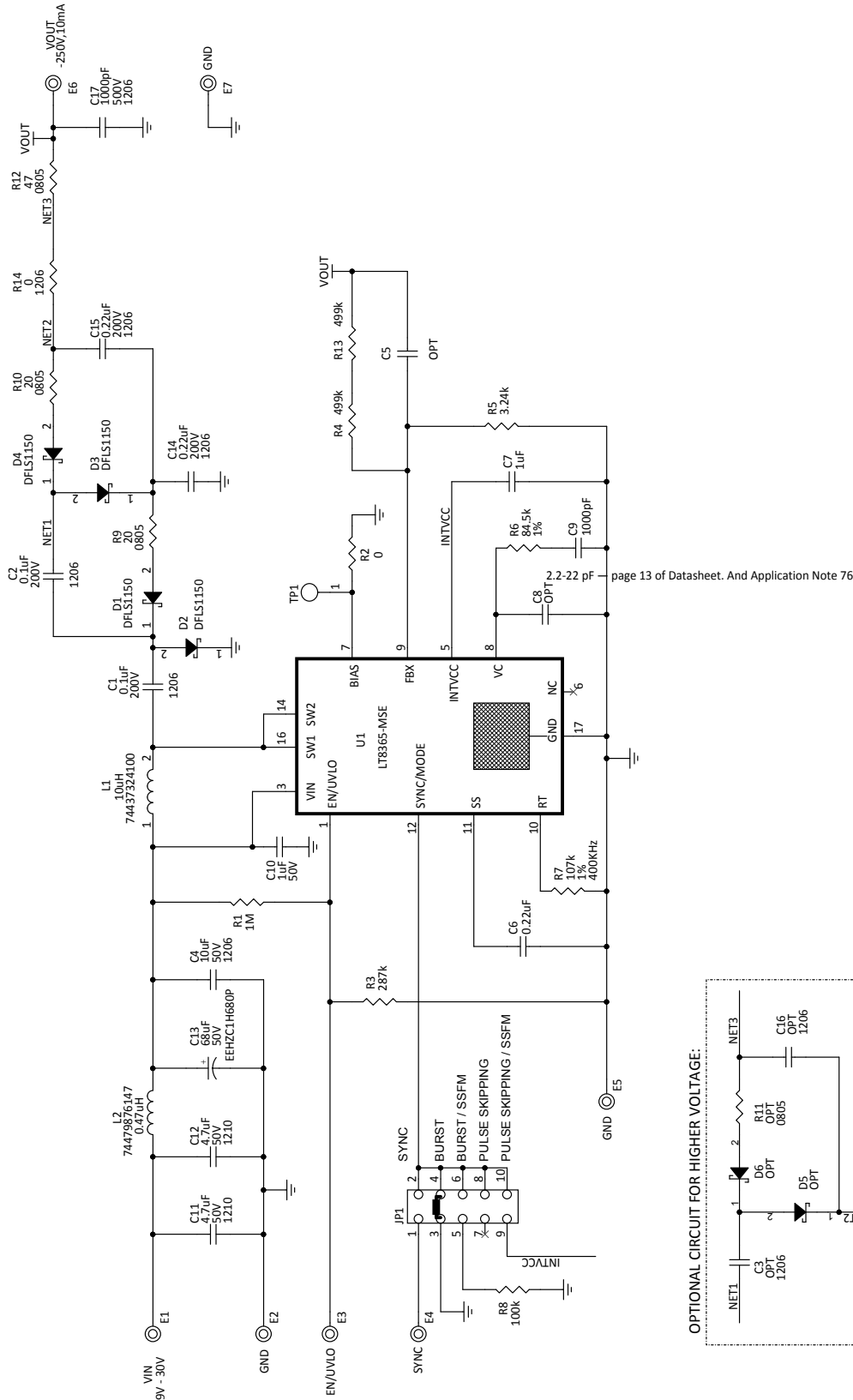

page 13 of Datasheet. And Application Note 76

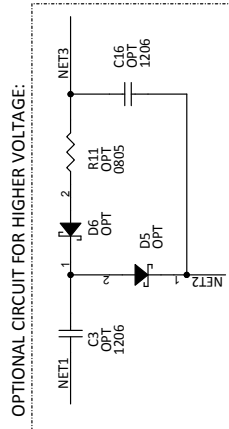

NOTES: UNLESS OTHERWISE SPECIFIED

- 1. ALL RESISTORS ARE 0603.
- ALL CAPACITORS ARE 0603.



## ESD Caution

**ESD (electrostatic discharge) sensitive device.** Charged devices and circuit boards can discharge without detection. Although this product features patented or proprietary protection circuitry, damage may occur on devices subjected to high energy ESD. Therefore, proper ESD precautions should be taken to avoid performance degradation or loss of functionality.

## Legal Terms and Conditions

By using the evaluation board discussed herein (together with any tools, components documentation or support materials, the "Evaluation Board"), you are agreeing to be bound by the terms and conditions set forth below ("Agreement") unless you have purchased the Evaluation Board, in which case the Analog Devices Standard Terms and Conditions of Sale shall govern. Do not use the Evaluation Board until you have read and agreed to the Agreement. Your use of the Evaluation Board shall signify your acceptance of the Agreement. This Agreement is made by and between you ("Customer") and Analog Devices, Inc. ("ADI"), with its principal place of business at One Technology Way, Norwood, MA 02062, USA. Subject to the terms and conditions of the Agreement, ADI hereby grants to Customer a free, limited, personal, temporary, non-exclusive, non-sublicensable, non-transferable license to use the Evaluation Board FOR EVALUATION PURPOSES ONLY. Customer understands and agrees that the Evaluation Board is provided for the sole and exclusive purpose referenced above, and agrees not to use the Evaluation Board for any other purpose. Furthermore, the license granted is expressly made subject to the following additional limitations: Customer shall not (i) rent, lease, display, sell, transfer, assign, sublicense, or distribute the Evaluation Board; and (ii) permit any Third Party to access the Evaluation Board. As used herein, the term "Third Party" includes any entity other than ADI, Customer, their employees, affiliates and in-house consultants. The Evaluation Board is NOT sold to Customer; all rights not expressly granted herein, including ownership of the Evaluation Board, are reserved by ADI. CONFIDENTIALITY. This Agreement and the Evaluation Board shall all be considered the confidential and proprietary information of ADI. Customer may not disclose or transfer any portion of the Evaluation Board to any other party for any reason. Upon discontinuation of use of the Evaluation Board or termination of this Agreement, Customer agrees to promptly return the Evaluation Board to ADI. ADDITIONAL RESTRICTIONS. Customer may not disassemble, decompile or reverse engineer chips on the Evaluation Board. Customer shall inform ADI of any occurred damages or any modifications or alterations it makes to the Evaluation Board, including but not limited to soldering or any other activity that affects the material content of the Evaluation Board. Modifications to the Evaluation Board must comply with applicable law, including but not limited to the RoHS Directive. TERMINATION. ADI may terminate this Agreement at any time upon giving written notice to Customer. Customer agrees to return to ADI the Evaluation Board at that time. LIMITATION OF LIABILITY. THE EVALUATION BOARD PROVIDED HEREUNDER IS PROVIDED "AS IS" AND ADI MAKES NO WARRANTIES OR REPRESENTATIONS OF ANY KIND WITH RESPECT TO IT. ADI SPECIFICALLY DISCLAIMS ANY REPRESENTATIONS, ENDORSEMENTS, GUARANTEES, OR WARRANTIES, EXPRESS OR IMPLIED, RELATED TO THE EVALUATION BOARD INCLUDING, BUT NOT LIMITED TO, THE IMPLIED WARRANTY OF MERCHANTABILITY, TITLE, FITNESS FOR A PARTICULAR PURPOSE OR NON-INFRINGEMENT OF INTELLECTUAL PROPERTY RIGHTS. IN NO EVENT WILL ADI AND ITS LICENSORS BE LIABLE FOR ANY INCIDENTAL, SPECIAL, INDIRECT, OR CONSEQUENTIAL DAMAGES RESULTING FROM CUSTOMER'S POSSESSION OR USE OF THE EVALUATION BOARD, INCLUDING BUT NOT LIMITED TO LOST PROFITS, DELAY COSTS, LABOR COSTS OR LOSS OF GOODWILL. ADI'S TOTAL LIABILITY FROM ANY AND ALL CAUSES SHALL BE LIMITED TO THE AMOUNT OF ONE HUNDRED US DOLLARS (\$100.00). EXPORT. Customer agrees that it will not directly or indirectly export the Evaluation Board to another country, and that it will comply with all applicable United States federal laws and regulations relating to exports. GOVERNING LAW. This Agreement shall be governed by and construed in accordance with the substantive laws of the Commonwealth of Massachusetts (excluding conflict of law rules). Any legal action regarding this Agreement will be heard in the state or federal courts having jurisdiction in Suffolk County, Massachusetts, and Customer hereby submits to the personal jurisdiction and venue of such courts. The United Nations Convention on Contracts for the International Sale of Goods shall not apply to this Agreement and is expressly disclaimed.