

# Service Manual

Pioneer



ORDER NO.  
RRV2392

STEREO CD TUNER

# XC-LA21

THIS MANUAL IS APPLICABLE TO THE FOLLOWING MODEL(S) AND TYPE(S).

Type	Model	Power Requirement	The voltage can be converted by the following method.
	XC-LA21		
DBDXCN	○	AC110-127V/220-230/240V	With the voltage selector
DDXCN/AR	○	AC110-127V/220-230/240V	With the voltage selector

## ● System Component Table

Component	Model	Service manual	Remarks
COMPACT MINI COMPONENT	X-LA21	RRV2370	
STEREO CD TUNER	XC-LA21	RRV2392	This manual.
STEREO POWER AMPLIFIER	M-LA21	RRV2393	
SPEAKER SYSTEM	S-LA21	RRV2394	

## CONTENTS

1. SAFETY INFORMATION .....	2	7. GENERAL INFORMATION .....	37
2. EXPLODED VIEWS AND PARTS LIST .....	4	7.1 DIAGNOSIS .....	37
3. BLOCK DIAGRAM AND SCHEMATIC DIAGRAM .....	8	7.1.1 TROUBLE SHOOTING .....	37
4. PCB CONNECTION DIAGRAM .....	20	7.1.2 DISASSEMBLY/ASSEMBLY .....	41
5. PCB PARTS LIST .....	30	7.2 PARTS .....	49
6. ADJUSTMENT .....	33	7.2.1 IC .....	49
		7.2.2 DISPLAY .....	51
		7.3 REMOTE CONTROL UNIT .....	52
		8. PANEL FACILITIES AND SPECIFICATIONS .....	54

PIONEER CORPORATION 4-1, Meguro 1-chome, Meguro-ku, Tokyo 153-8654, Japan  
 PIONEER ELECTRONICS SERVICE, INC. P.O. Box 1760, Long Beach, CA 90801-1760, U.S.A.  
 PIONEER EUROPE NV Haven 1087, Keetberglaan 1, 9120 Melsele, Belgium  
 PIONEER ELECTRONICS ASIACENTRE PTE. LTD. 253 Alexandra Road, #04-01, Singapore 159936  
 © PIONEER CORPORATION 2000

# 1. SAFETY INFORMATION

This service manual is intended for qualified service technicians ; it is not meant for the casual do-it-yourselfer. Qualified technicians have the necessary test equipment and tools, and have been trained to properly and safely repair complex products such as those covered by this manual. Improperly performed repairs can adversely affect the safety and reliability of the product and may void the warranty. If you are not qualified to perform the repair of this product properly and safely, you should not risk trying to do so and refer the repair to a qualified service technician.

## LABEL CHECK

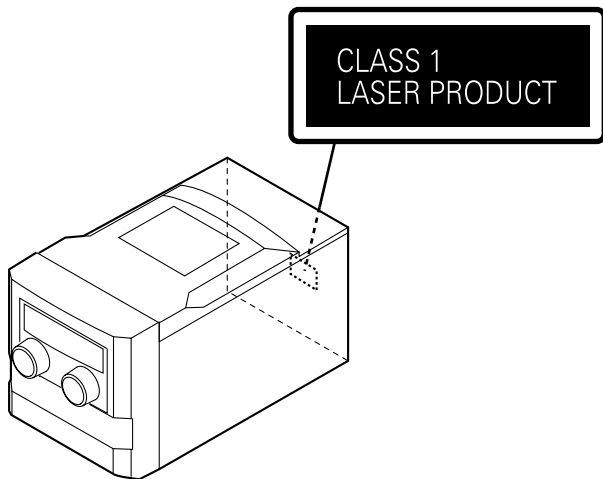

— IMPORTANT —  
THIS PIONEER APPARATUS CONTAINS  
LASER OF CLASS 1.  
SERVICING OPERATION OF THE APPARATUS  
SHOULD BE DONE BY A SPECIALLY  
INSTRUCTED PERSON.

— LASER DIODE CHARACTERISTICS —  
MAXIMUM OUTPUT POWER: 5 mW  
WAVELENGTH: 760 - 800 nm

— Additional Laser Caution —

- 1. Laser Interlock Mechanism**  
The position of the switch for detecting loading state is detected by the system microprocessor, and the design prevents laser diode oscillation when the switch is pressed physically.  
Thus, the interlock will no longer function if the switch is released physically and deliberately.  
Laser diode oscillation will continue, if pin 46 of TA2065F (IC2) on the CD SERVO PCB ASSY is connected to GND, or else the terminals of Q1 are shorted to each other (fault condition).
- 2. When the cover is opened, close viewing of the objective lens with the naked eye will cause exposure to a Class 1 laser beam.**

## 2. EXPLODED VIEWS AND PARTS LIST

- NOTES: ● Parts marked by "NSP" are generally unavailable because they are not in our Master Spare Parts List.  
 ● The  $\Delta$  mark found on some component parts indicates the importance of the safety factor of the part. Therefore, when replacing, be sure to use parts of identical designation.  
 ● Screws adjacent to  $\nabla$  mark on the product are used for disassembly.

### 2.1 PACKING (X-LA21)

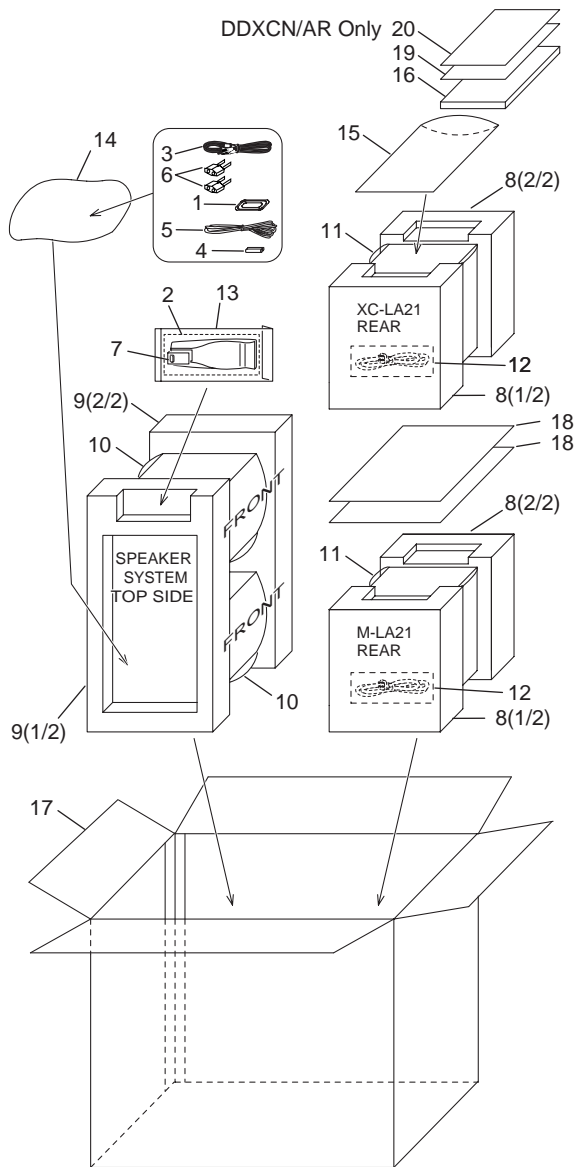

#### (1) PACKING PARTS LIST

Mark	No.	Description	Part No.
	1	AM Loop Antenna	ANT-PMT1E-AL
	2	Remote Control Unit	AXD7289
	3	RCA Audio Cable	122003220100
NSP	4	'AAA' Size R03 Batteries	130115004000
	5	FM Wire Antenna	132030001001
	6	Power-cord Plug Conversion Adaptor	138011722000
	7	Battery Door	500RC4603070
	8	Polyform Unit	800PMT190001
	9	Polyfoam (Speaker)	800PMT390000
	10	Poly Foam Sheet (C) SP	801999000002
	11	Polythenefoam Sheet	801999000005
NSP	12	PE Polybag (AC Cord)	805032115000
NSP	13	PE Polybag (Remocon)	805035105000
NSP	14	PE Polybag (Antenna)	805070100000
NSP	15	PE Polybag (I Book)	805085140000
	16	Operating Instructions (English/Spanish/Chinese)	811PMT391011
	17	Carton	See Contrast table (2)
	18	Corrugate Card	815001405213
	19	Additional Sheet	810PMT395010
	20	Correction Sheet	See Contrast table (2)

#### (2) CONTRAST TABLE

X-LA21/DBDXCN and DDXCN/AR are constructed the same except for the following :

Mark	No.	Symbol and Description	Part No.		Remarks
			X-LA21 /DBDXCN	X-LA21 /DDXCN/AR	
	17	Carton	813PMT393020	813PMT393010	
	20	Correction Sheet	Not used	810PMT395020	

2.2 EXTERIOR SECTION

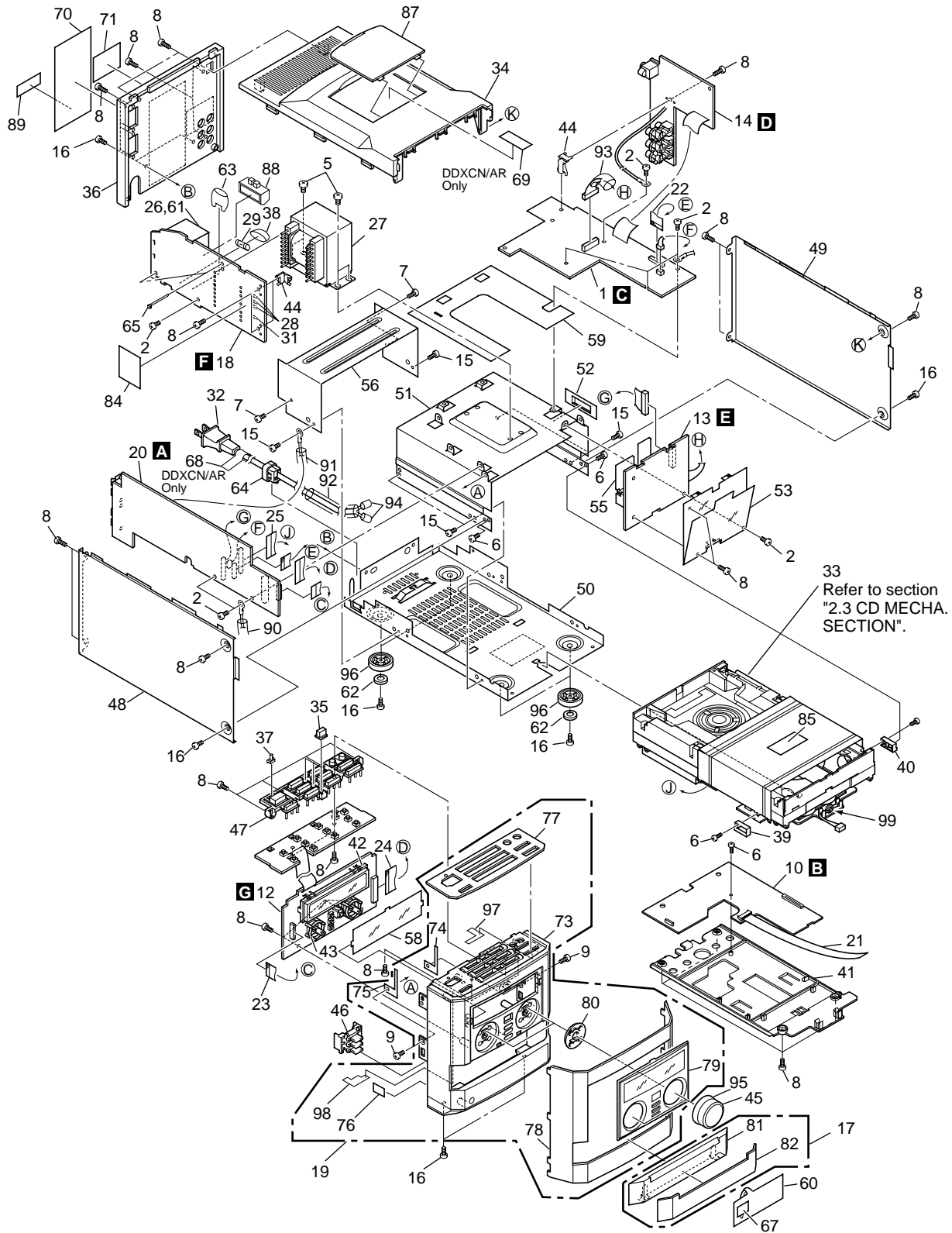

**(1) EXTERIOR SECTION PARTS LIST**

Mark	No.	Description	Part No.	Mark	No.	Description	Part No.
	1	AUDIO Assy	PMT101000210		51	Transformer Bracket	605PMT122000
	2	Screw	BBZ30P060FMC		52	FCC Cable HLD	605PMT142000
	3	•••••			53	Cable Holder	605PMT143000
	4	•••••			54	•••••	
	5	Screw	BBZ40P060FMC		55	Heat Sink	613PMT131000
	6	Screw	BPZ20P050FMC		56	CD Shield Plate	650PMT139000
	7	Screw	BPZ26P080FMC		57	•••••	
	8	Screw	BPZ30P100FNI		58	Display Filter Plate	650PMT147002
	9	Screw	CBZ30P060FMC		59	PC Sheet	650PMT149000
	10	CD Assy	CD--PMT1E		60	Transport Stopper PL	650PMT197010
	11	•••••			61	Shielding Plate	650277225000
	12	DISPLAY/CTL Assy	PMT101000041		62	Rubber Foot	700PMT384000
	13	RECT ASSY	PMT1LA100061		63	Capacitor Boot	700PMT150000
	14	AUX Assy	PMT1LA100091		64	Bushing	700PMT156000
	15	Screw	KBZ30P040FMC		65	Cable/Plastic Tie	727000100000
	16	Screw	KBZ30P060FNI		66	•••••	
	17	CD DOOR Assy	PMT3CDDR-DB	NSP	67	Trans. Stopper Label	809PMT194021
	18	TRANS Assy	PMT1LA100071		68	AC Cord Label	See Contrast table (2)
	19	S-Assy PMT3 FP01	SUBPMT3CDFP		69	Voltage Label	See Contrast table (2)
	20	STD. TUNER Assy	TUN-PMT1E-DL		70	Warning Label	See Contrast table (2)
	21	FFC Cable 16Pin L100	040160100101		71	Back Label	See Contrast table (2)
	22	FFC Cable 16Pin L260	040160260100		72	•••••	
	23	FFC Cable 17Pin L100	040170100100	NSP	73	Front Panel	500PMT101002
	24	FFC Cable 24Pin L200	040240200130	NSP	74	GND. Copper Plate C	650PMT152000
	25	FFC Cable 30Pin L400	040300400100	NSP	75	GND. Copper Plate D	650PMT153000
△	26	STANDBY TRANSFORMER	1233D4828140	NSP	76	GND. Copper Plate E	650PMT155000
△	27	Power TF EI35 11-24V	1231D3513140	NSP	77	Control Panel Plate	650PMT116020
△	28	Micro Fuse 251001	124010010002	NSP	78	Front Cover	600PMT160010
△	29	Fuse (500mA/250V)	124005020002	NSP	79	Display Lens	500PMT106020
	30	•••••		NSP	80	Illuminated Ring	509PMT105000
△	31	Micro Fuse #25103.5	124035010000	NSP	81	CD Door	500PMT102002
△	32	AC Cord	See Contrast table (2)	NSP	82	CD Door Cover	600PMT120020
△	33	CD MECHA,CMCJ	153000117000		83	•••••	
	34	Top Panel	500PMT148002		84	PCB Insulation Sheet	650PMT157000
	35	Direct Access Knob Lens	500PMT111000		85	CD Caution Label	See Contrast table (2)
	36	Back Cover	500PMT183000		86	•••••	
	37	Power Standby Lens	500PMT129000		87	Voltage Sel. Cover	500PMT110002
	38	Fuse Insulation Cap	500623200000		88	Voltage Sel. Knob	510PMT112002
	39	CD Base Adaptor R	503PMT125000	NSP	89	Serial Label	809000009000
	40	CD Base Adaptor L	503PMT126000		90	Tube AWG5 D4.72 L70	728000047L07
	41	Servo PCB Bracket	505PMT114000		91	Tube AWG5 D4.72 L90	728000047L09
	42	FL Bracket	505PMT134000		92	Tube AWG1 D7.35 L120	728000073L12
	43	LED Bracket	505PMT135000		93	Tube AWG1 D7.35 L160	728000073L16
	44	PCB Mounting Bracket	505PMT136000		94	Tube AWG1 D7.35 L15	728000073L15
	45	Volume Knob	510PMT328001		95	Volume Chrome Ring	509PMT330001
	46	Clock Control Knob	510PMT108002		96	Foot Stand	509PMT329000
	47	Direct Access Knob Set	510PMT109020	NSP	97	GND. Copper Plate A	650PMT140000
	48	Side Panel-L	600PMT117002	NSP	98	GND. Copper Plate B	650PMT141000
	49	Side Panel-R	600PMT118002		99	Ferrite Core	032219180000
NSP	50	Bottom Tray	600PMT121000				

**(2) CONTRAST TABLE**

XC-LA21/DBDXCN and DDXCN/AR are constructed the same except for the following :

Mark	No.	Symbol and Description	Part No.		Remarks
			XC-LA21 /DBDXCN	XC-LA21 /DDXCN/AR	
△	32	AC Cord	134250220000	134220120016	
	68	AC Cord Label	Not used	809PMT394100	
	69	Voltage Label	Not used	809PMT394080	
	70	Warning Label	809PMT396110	809PMT394010	
	71	Back Label	809PMT396030	809PMT396050	
	85	CD Caution Label	809PMT194070	809PMT394090	

2.3 CD MECHA. SECTION

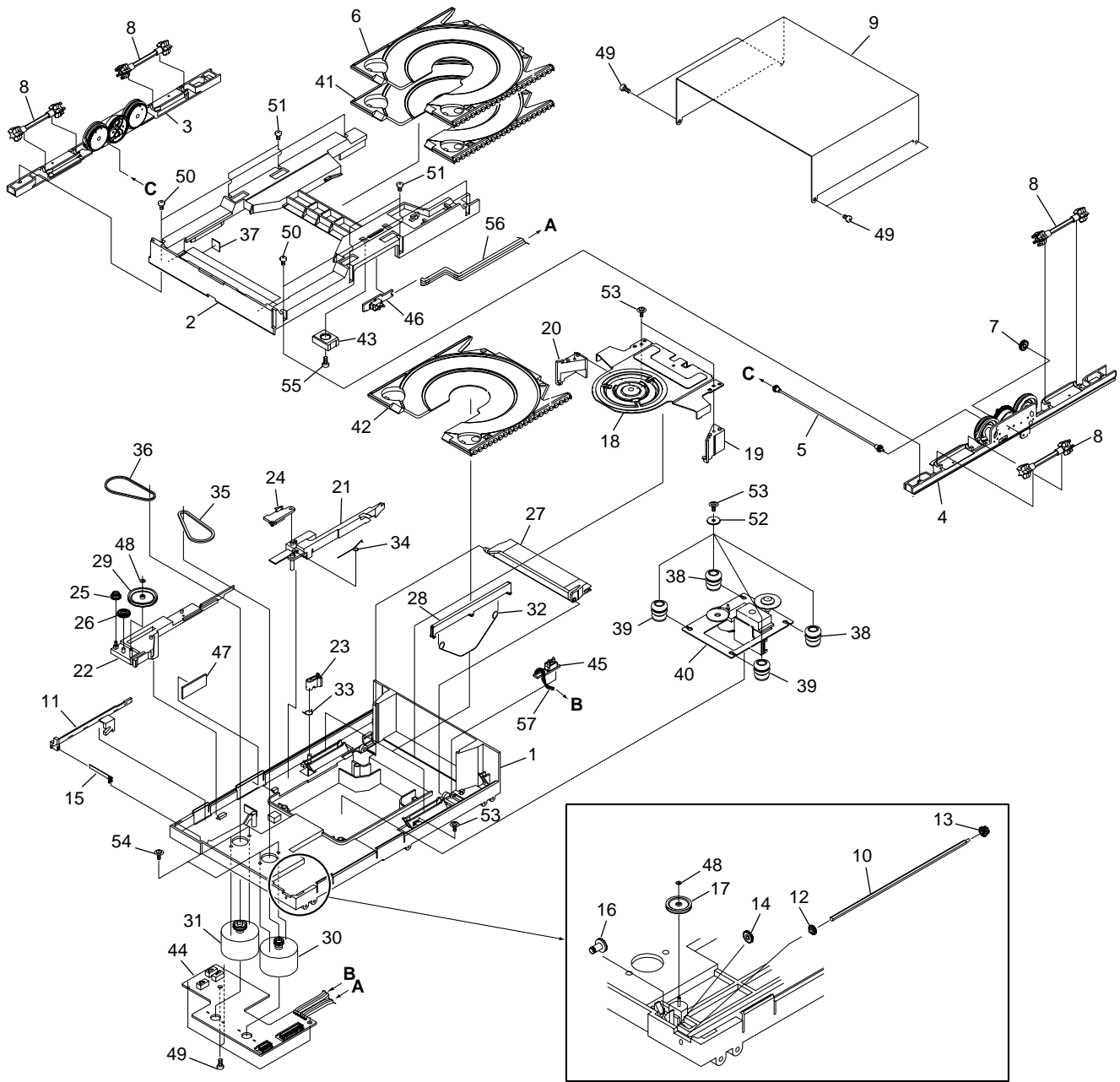

## ● CD MECHA. SECTION PARTS LIST

Mark	No.	Description	Part No.	Mark	No.	Description	Part No.
	1	Assy Chassis	45-093-4256		31	Assy Motor DRW S	45-093-4239
	2	Drawer 2	45-264-3278		32	Spring	01-080-4541
	3	Assy Holder L	45-093-3241		33	Spring	01-082-4643
	4	Assy Holder R3B	45-093-3296		34	Spring	01-082-4647
	5	Assy Gear Drive	45-093-4243		35	Belt	02-083-4171
	6	Assy Carriage 101	45-093-4347		36	Belt	02-083-4172
	7	Bevel Gear 4	45-222-4214		37	Cushion	45-063-4136
	8	Assy Gear Star	45-093-4244		38	Insulator	45-063-3201
	9	Cover 2	45-112-3154		39	Insulator	45-063-3202
	10	Shaft	45-300-4173		40	Pickup Unit	KSM213CCM
	11	Slider 4	45-259-3175		41	Assy Carriage 201	45-093-4348
	12	Gear Spline	45-222-4021		42	Assy Carriage 301	45-093-4349
	13	Bevel Gear 1	45-222-4059		43	Spacer SW	45-219-4127
	14	Gear Idler 1	45-222-4176		44	Assy PC Board A	45-093-4263
	15	Plate Spring	45-160-4174		45	Assy PC Board B	45-093-4265
	16	Bevel Gear 3	45-222-4177		46	Assy PC Board C	45-093-4264
	17	Pulley C	45-222-4058		47	Rubber Cushion	45-063-4115
	18	Assy Clamper SO	45-093-4358		48	Washer	GWP15X045025S
	19	Arm Slider R	45-219-3187		49	Screw	GSL20A2606
	20	Arm Slider L	45-219-3188		50	Screw	GSL20B2006
	21	Slider 1	45-259-2185		51	Screw	GSL10B2006
	22	Assy Slider 2	45-093-3240		52	Washer	GWN31X120050
	23	Arm Stopper A2	45-239-4279		53	Screw	GSL15A2608
	24	Arm Stopper B	45-239-4065		54	Screw	GSP14A2604
	25	Gear Idler A	45-222-4128		55	Screw	GST15A2005
	26	Gear Idler C	45-222-4051		56	Lead Wire	45-072-4171
	27	Lever 2	45-259-3289		57	Lead Wire	45-072-4172
	28	Lifter	45-259-3025				
	29	Pulley A	45-229-4052				
	30	Assy Motor CRG S	45-093-4238				

### 3. BLOCK DIAGRAM AND SCHEMATIC DIAGRAM

#### 3.1 BLOCK DIAGRAM

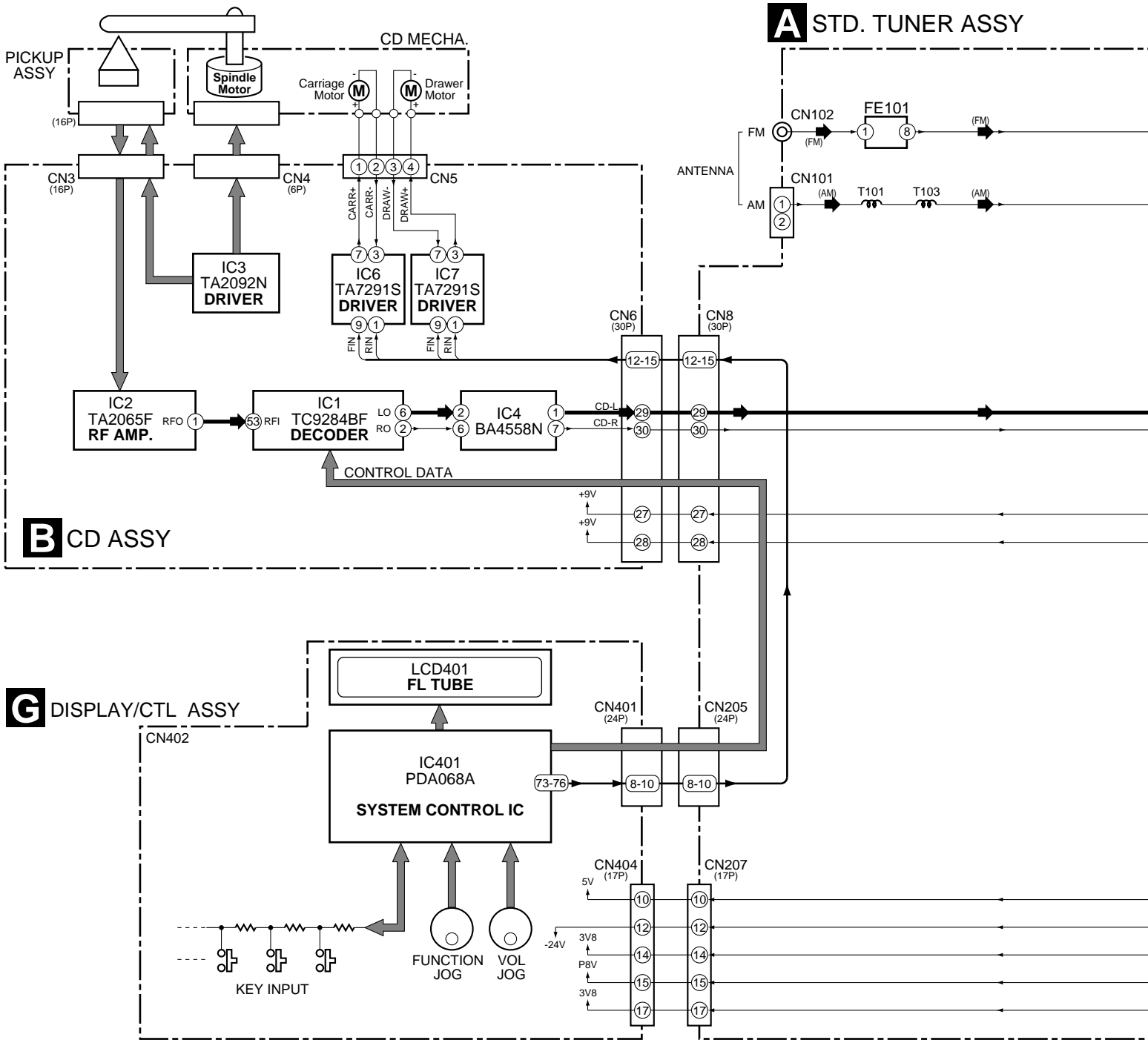



- ➔ : AUDIO SIGNAL ROUTE (RF/CD)
- (T) ➔ : AUDIO SIGNAL ROUTE (TUNER)
- (AM) ➔ : AUDIO SIGNAL ROUTE (AM)
- (FM) ➔ : AUDIO SIGNAL ROUTE (FM)
- (AU) ➔ : AUDIO SIGNAL ROUTE (AUX)
- (PH) ➔ : AUDIO SIGNAL ROUTE (PHONES)

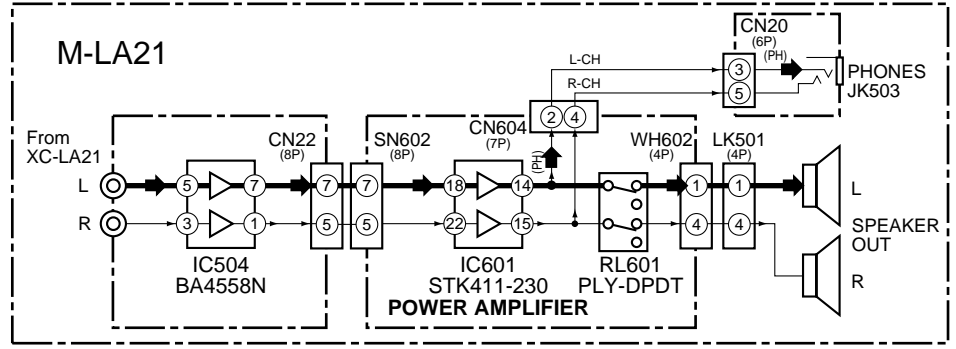

**D** AUX ASSY

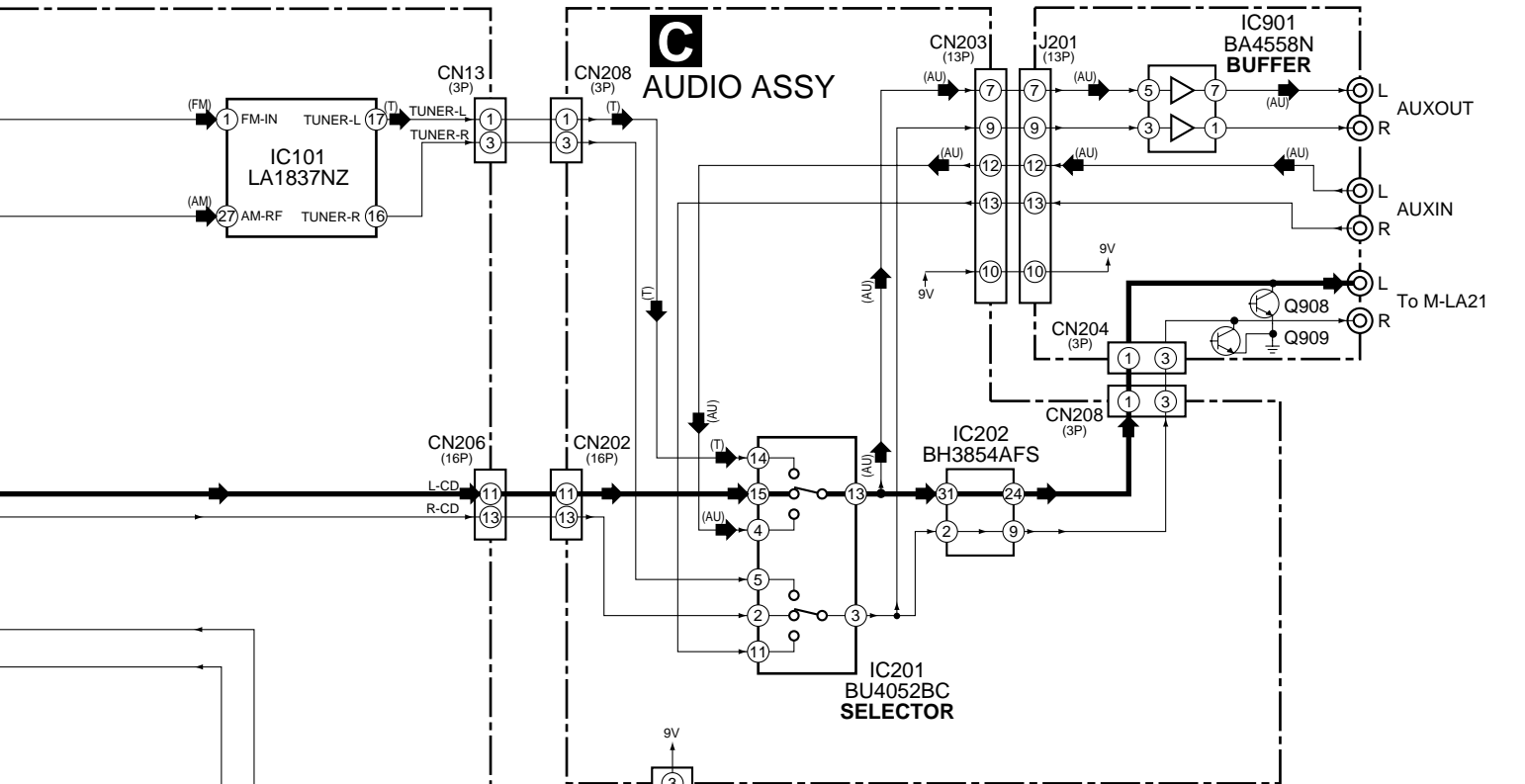

**C** AUDIO ASSY

**E** RECT ASSY

**F** TRANS ASSY

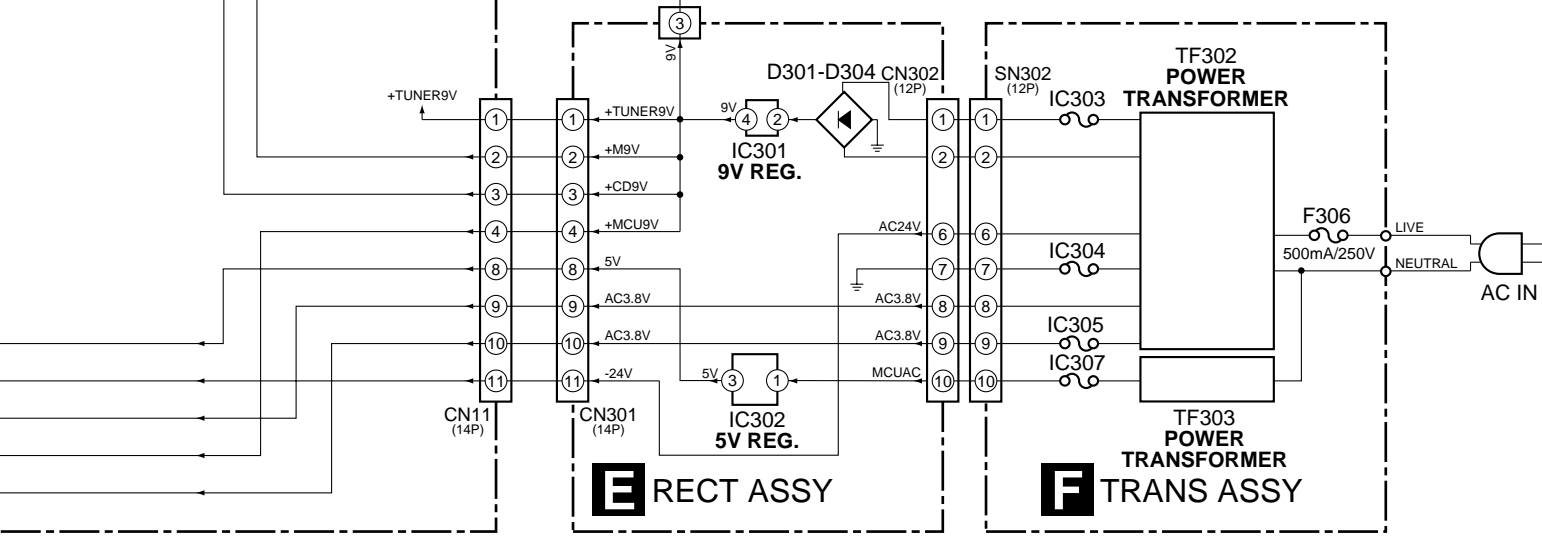

### 3.2 OVERALL WIRING DIAGRAM

A

B

C

D

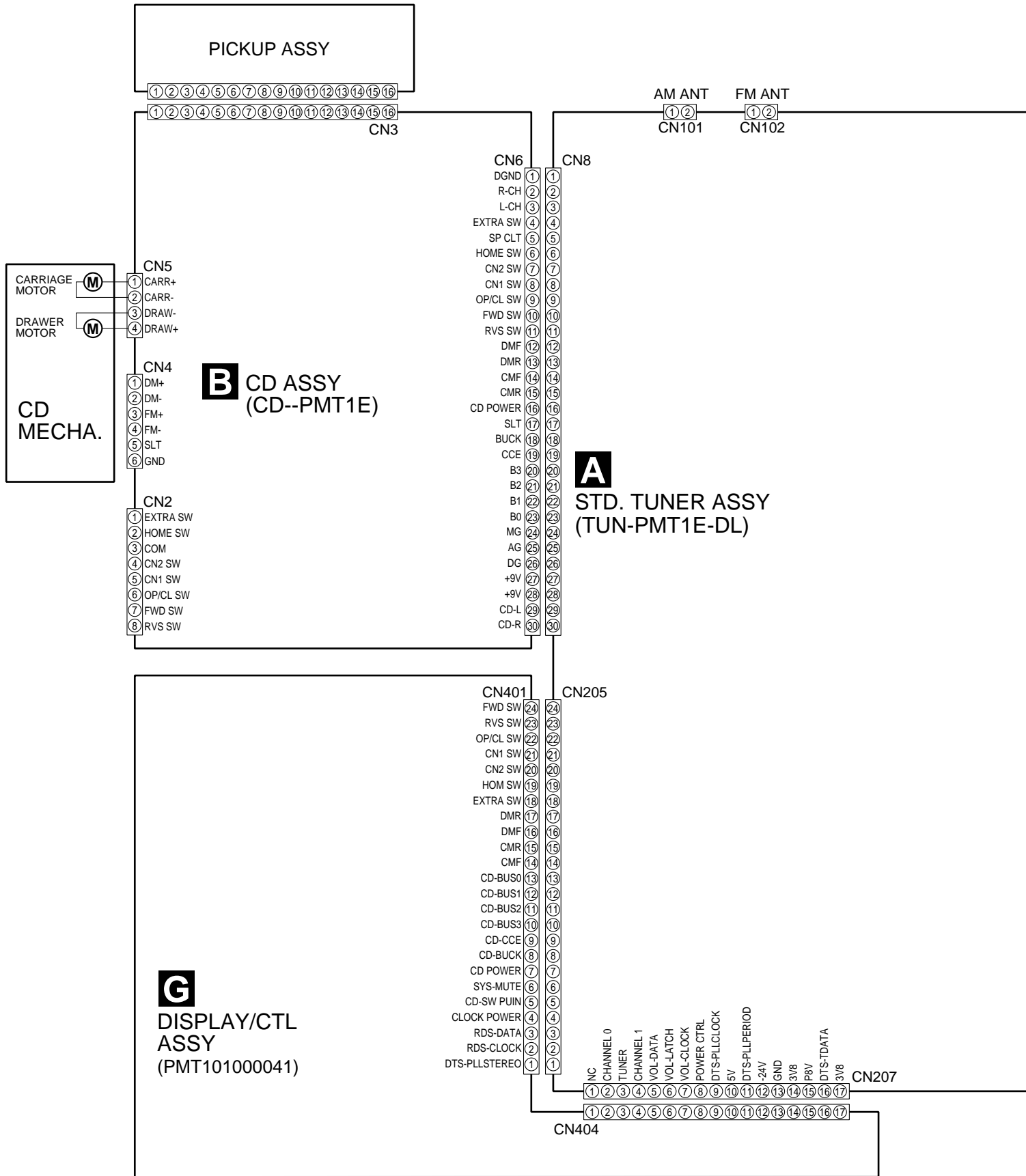

Note : When ordering service parts, be sure to refer to "EXPLODED VIEWS and PARTS LIST" or "PCB PARTS LIST".

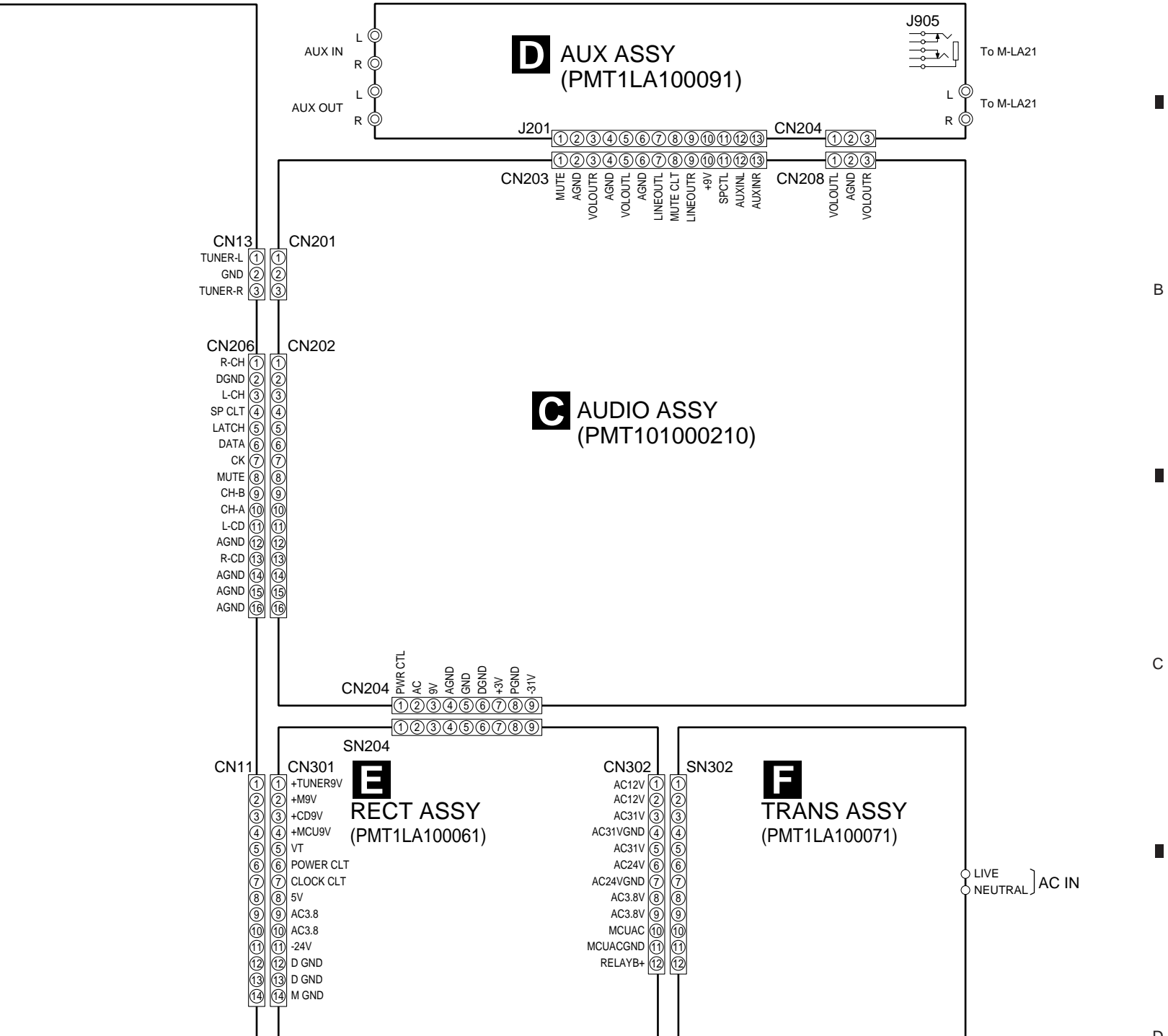

3.3 STD. TUNER ASSY

A

B

C

D

CN301

CN202

CN404

CN401

CN205

CN8

CN6

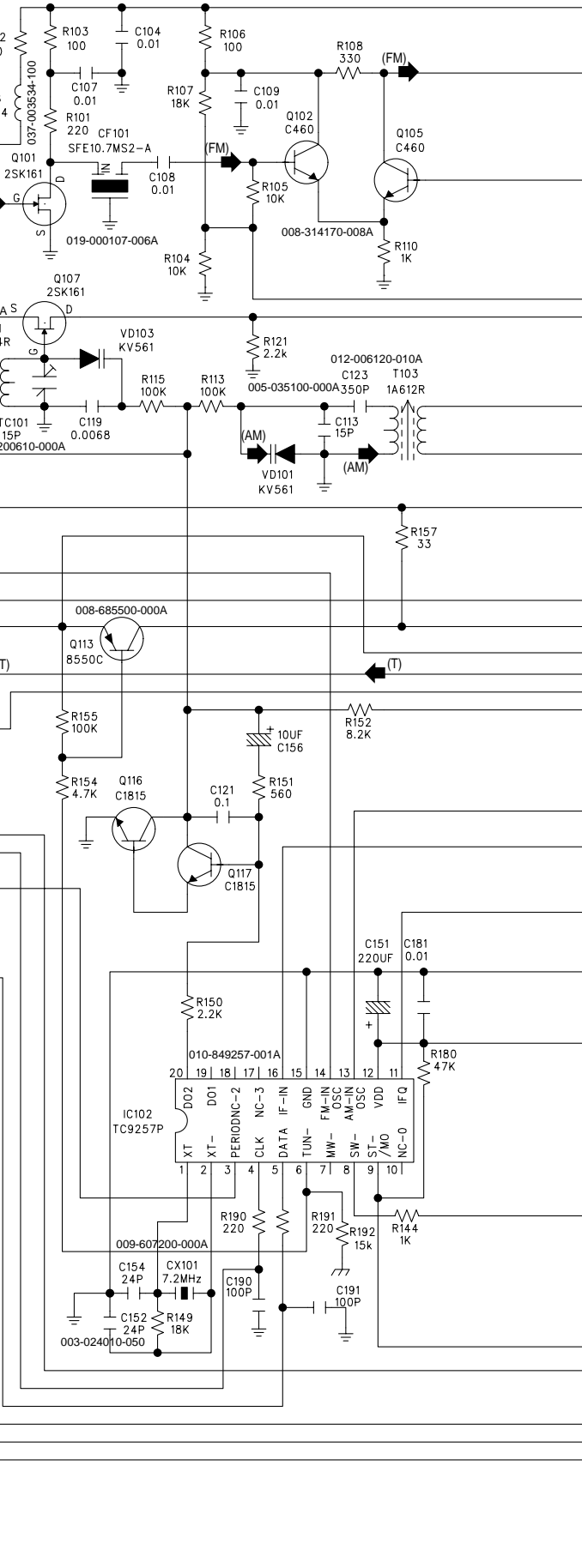
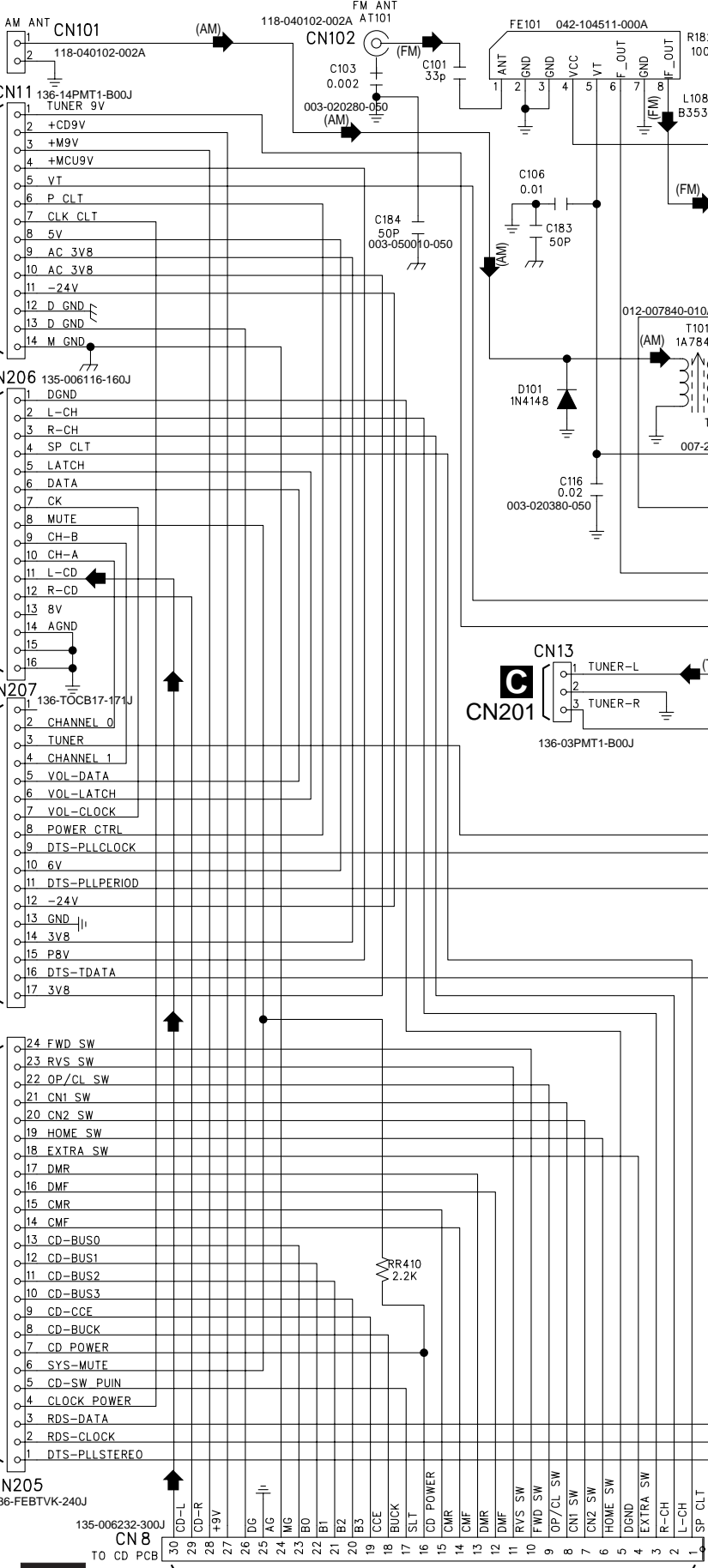

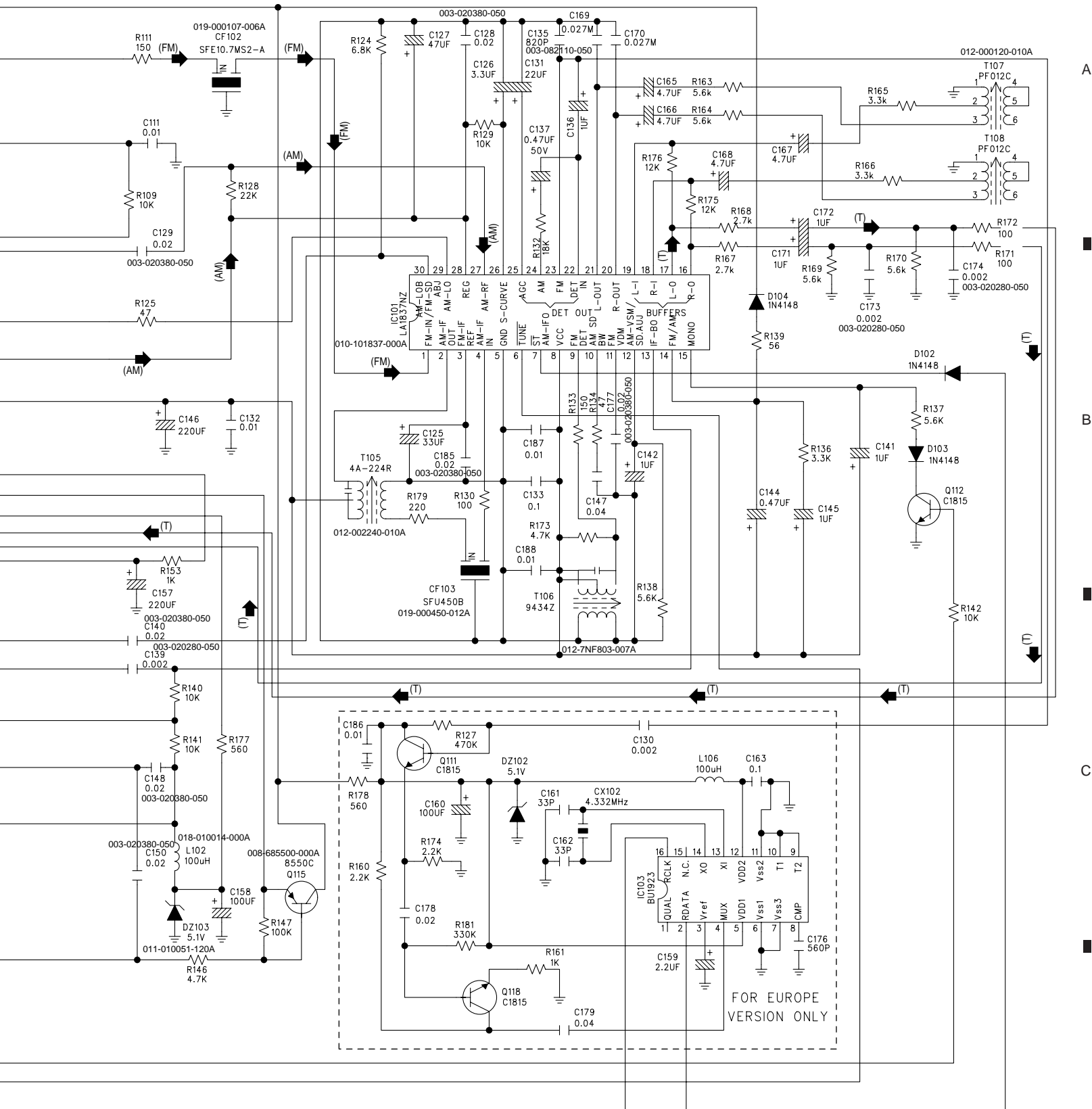

**A** STD. TUNER ASSY  
(TUN-PMT1E-DL)

- ➔ : AUDIO SIGNAL ROUTE (RF/CD)
- (T) ➔ : TUNER SIGNAL ROUTE
- (AM) ➔ : TUNER SIGNAL ROUTE (AM)
- (FM) ➔ : TUNER SIGNAL ROUTE (FM)



3.4 CD ASSY

A

B

C

D

A CN8

CD MECHA. CN2

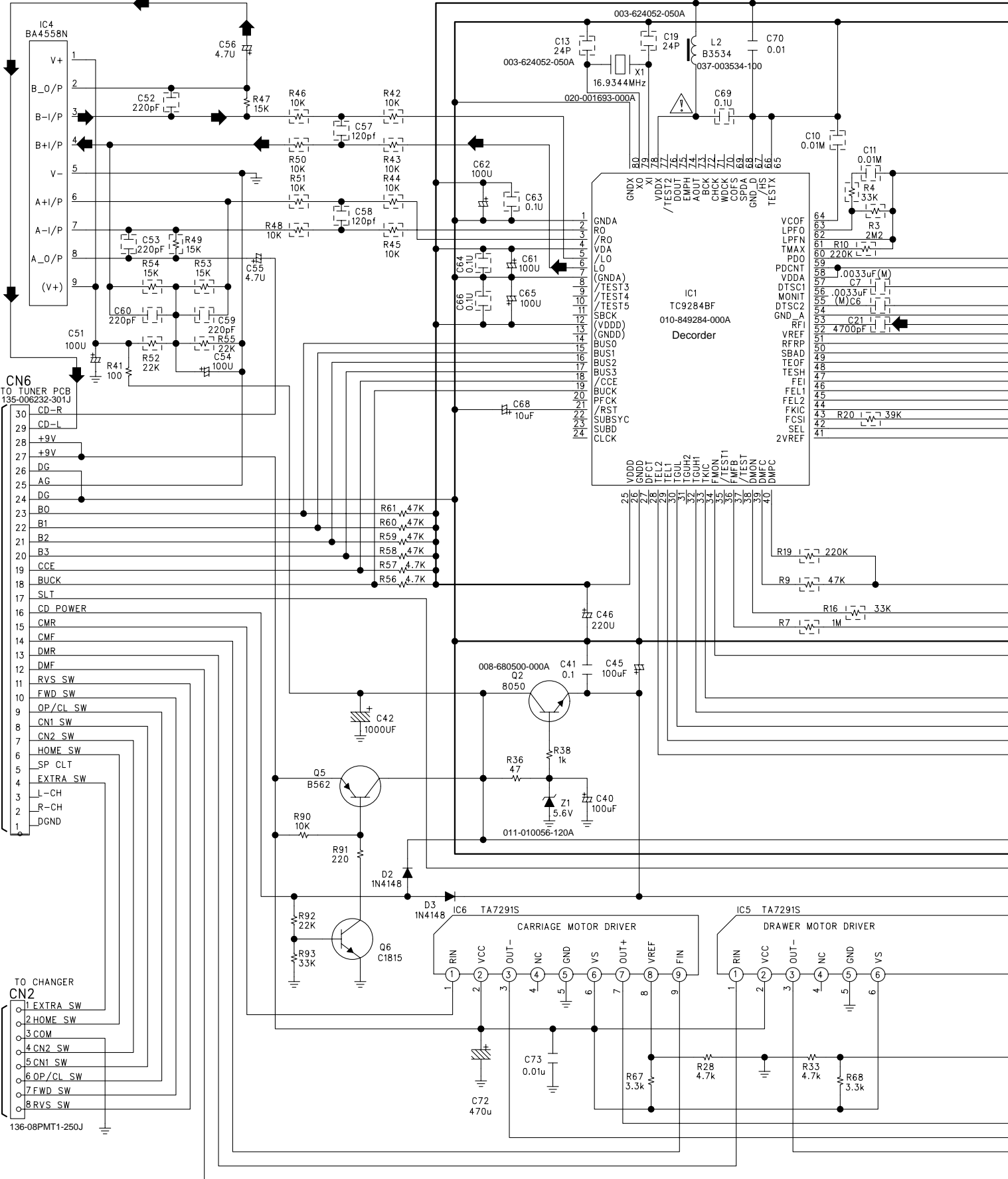

**B** CD ASSY (CD--PMT1E)

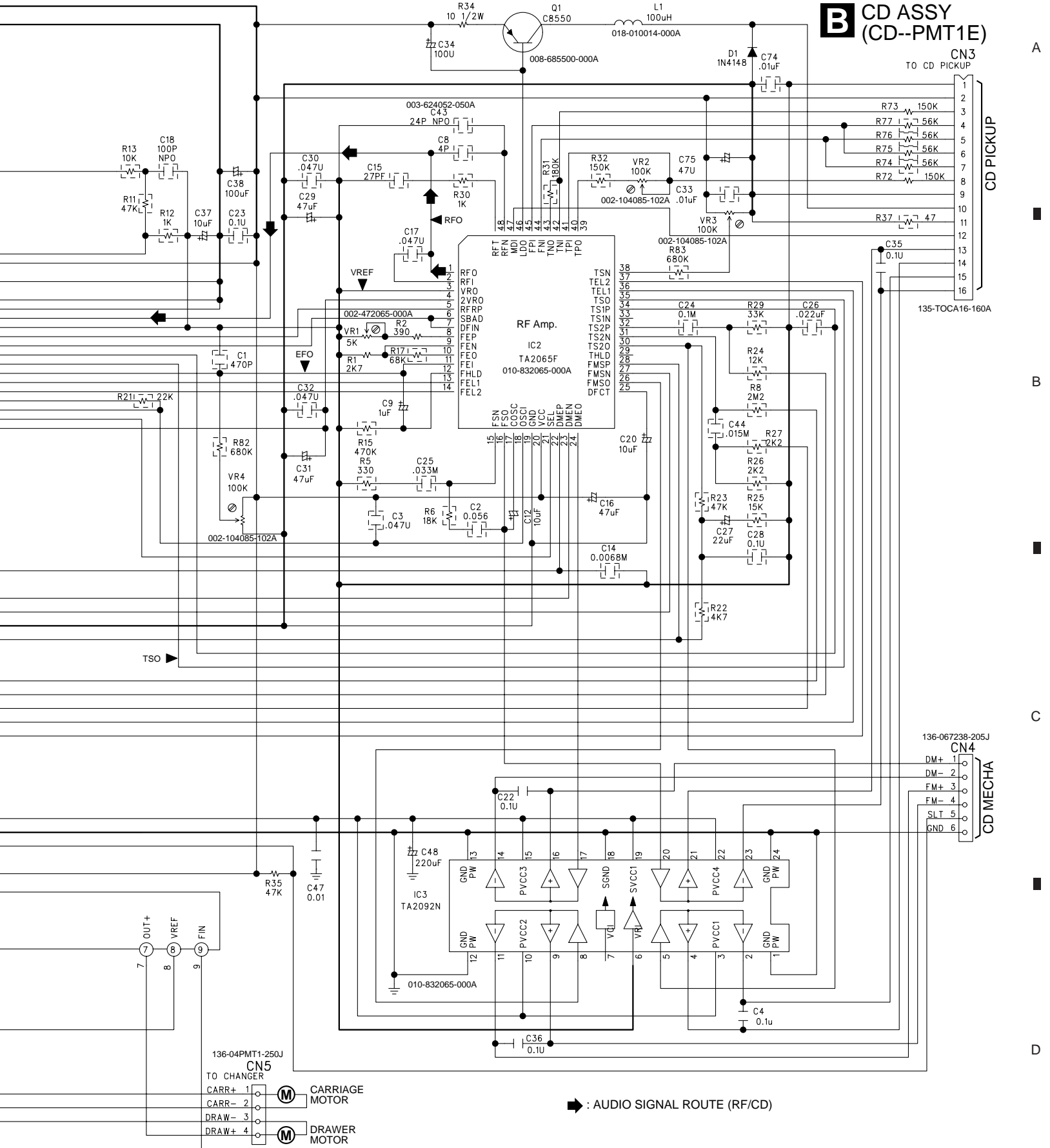

A

CD PICKUP

1

2

3

4

5

6

7

8

9

10

11

12

13

14

15

16

135-TOCA16-160A

B

C

CD MECHA

DM+ 1

DM- 2

FM+ 3

FM- 4

SILT 5

GND 6

D

### 3.5 AUDIO, AUX, RECT and TRANS ASSYS

A

B

C

D

**A** CN13 135-PHS030-030J  
 CN201 CN202 TO TUNER PCB 135-006116-160J  
**A** CN206

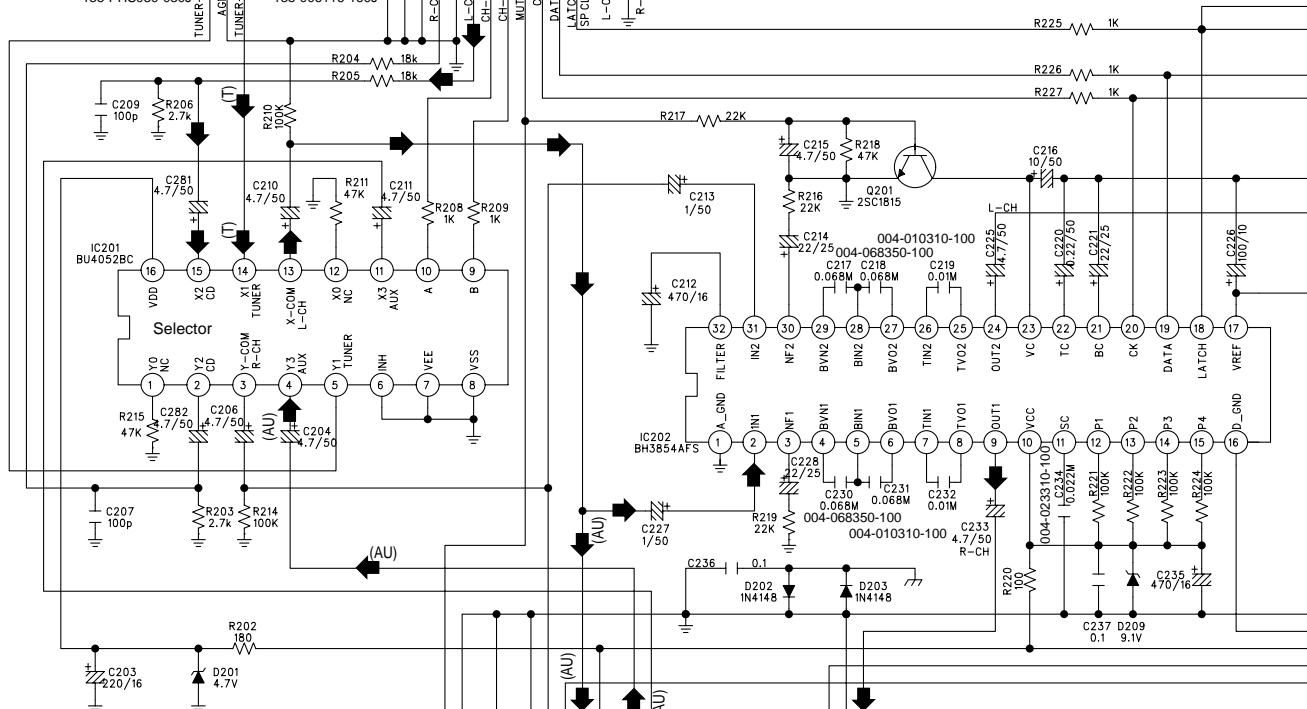

**C** AUDIO ASSY (PMT101000210)

**D** CN904

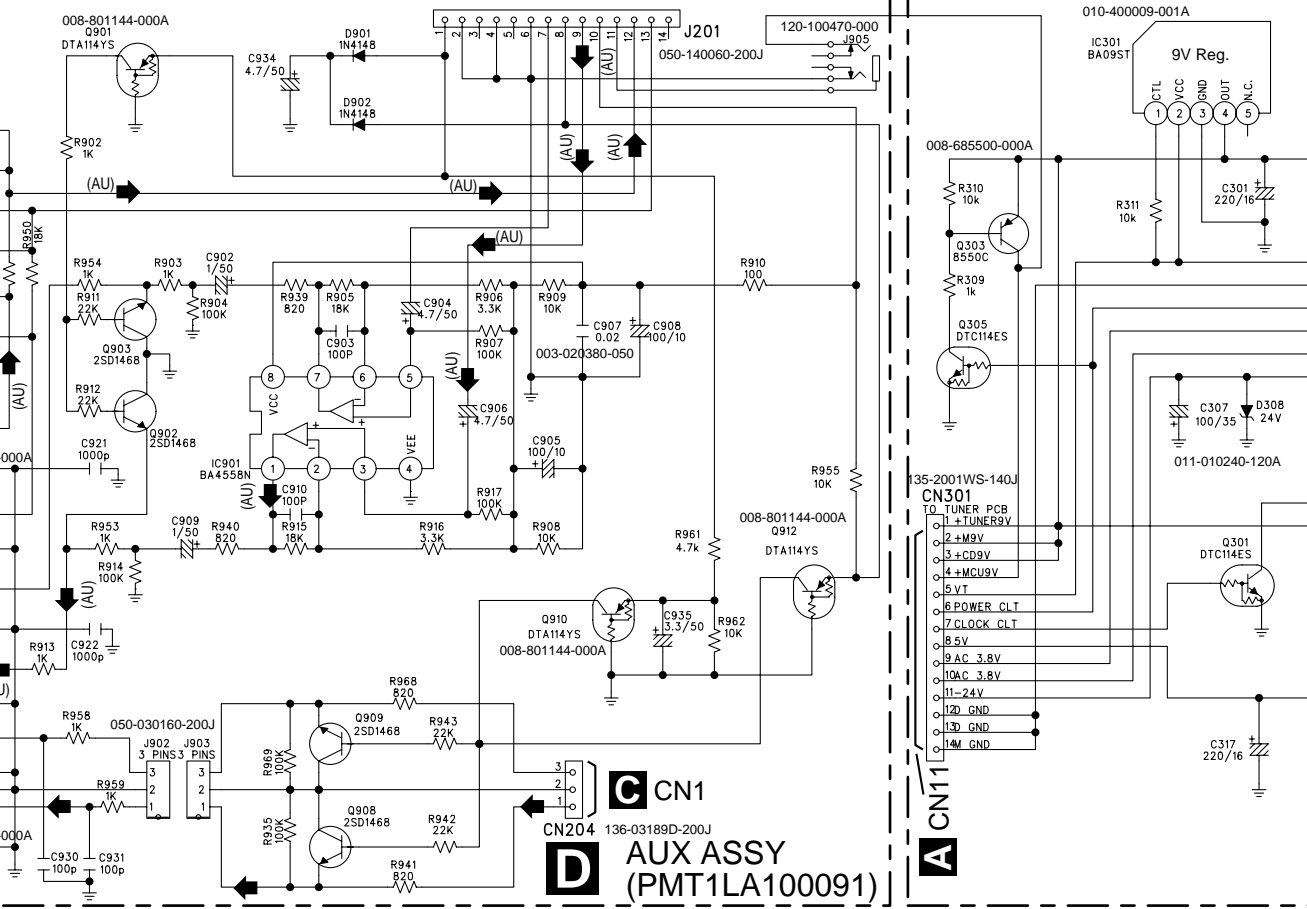

**C** CN1 136-03189D-200J  
**D** AUX ASSY (PMT1LA100091)

**A** CN11



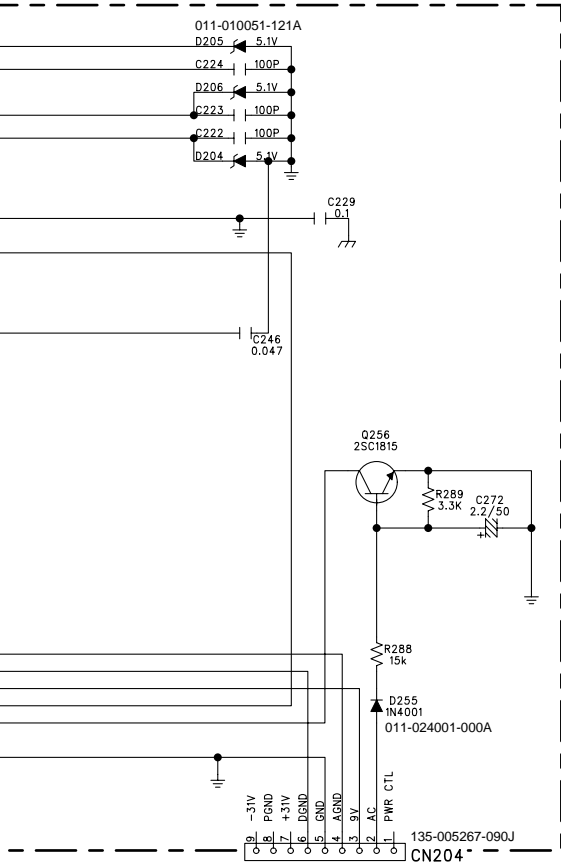

- ➡ : AUDIO SIGNAL ROUTE (RF/CD)
- (T) ➡ : TUNER SIGNAL ROUTE
- (AU) ➡ : AUDIO SIGNAL ROUTE (AUX)

• NOTE FOR FUSE REPLACEMENT

**CAUTION** -FOR CONTINUED PROTECTION AGAINST RISK OF FIRE. REPLACE WITH SAME TYPE AND RATINGS ONLY.

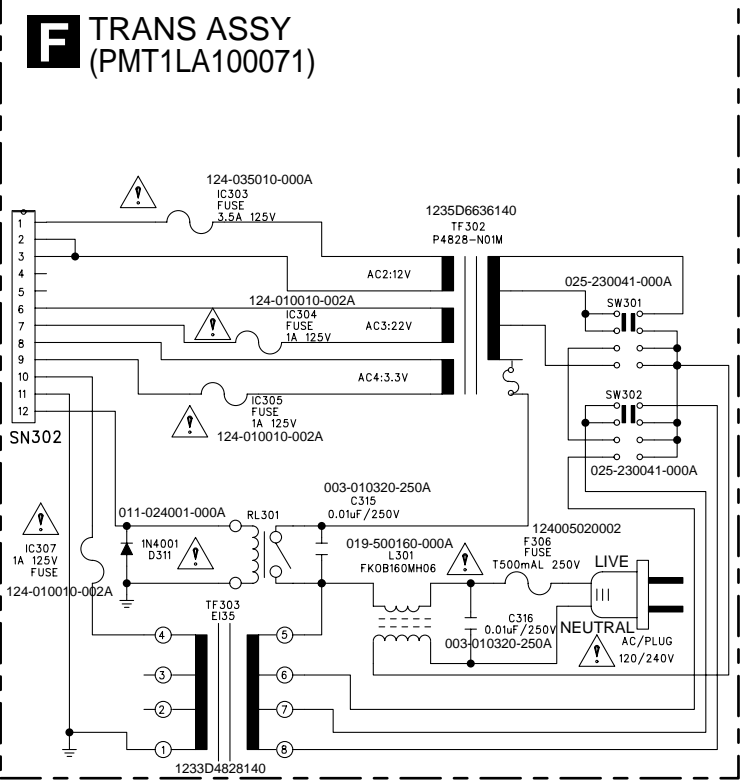
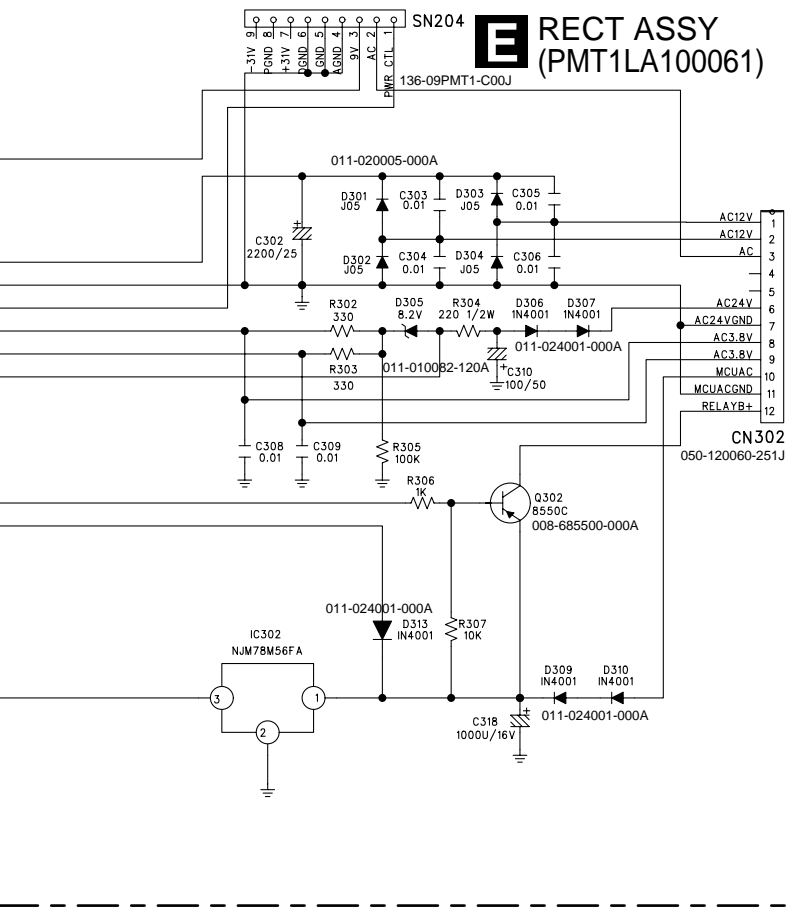

### 3.6 DISPLAY/CTL ASSY

## G DISPLAY/CTL ASSY (PMT101000041)

A

B

C

D

A CN205

For DOWNLOAD  
CN402

A CN207

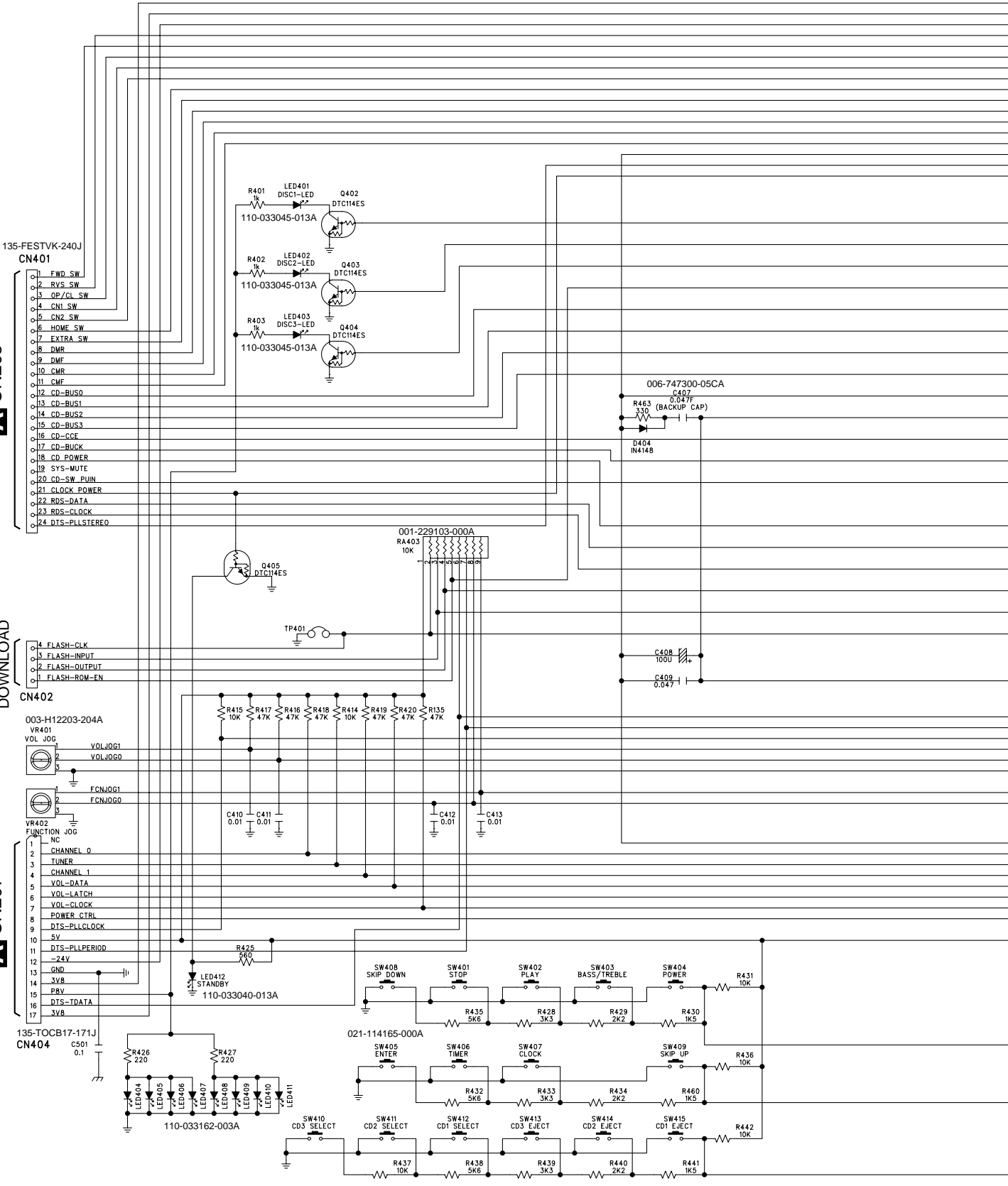

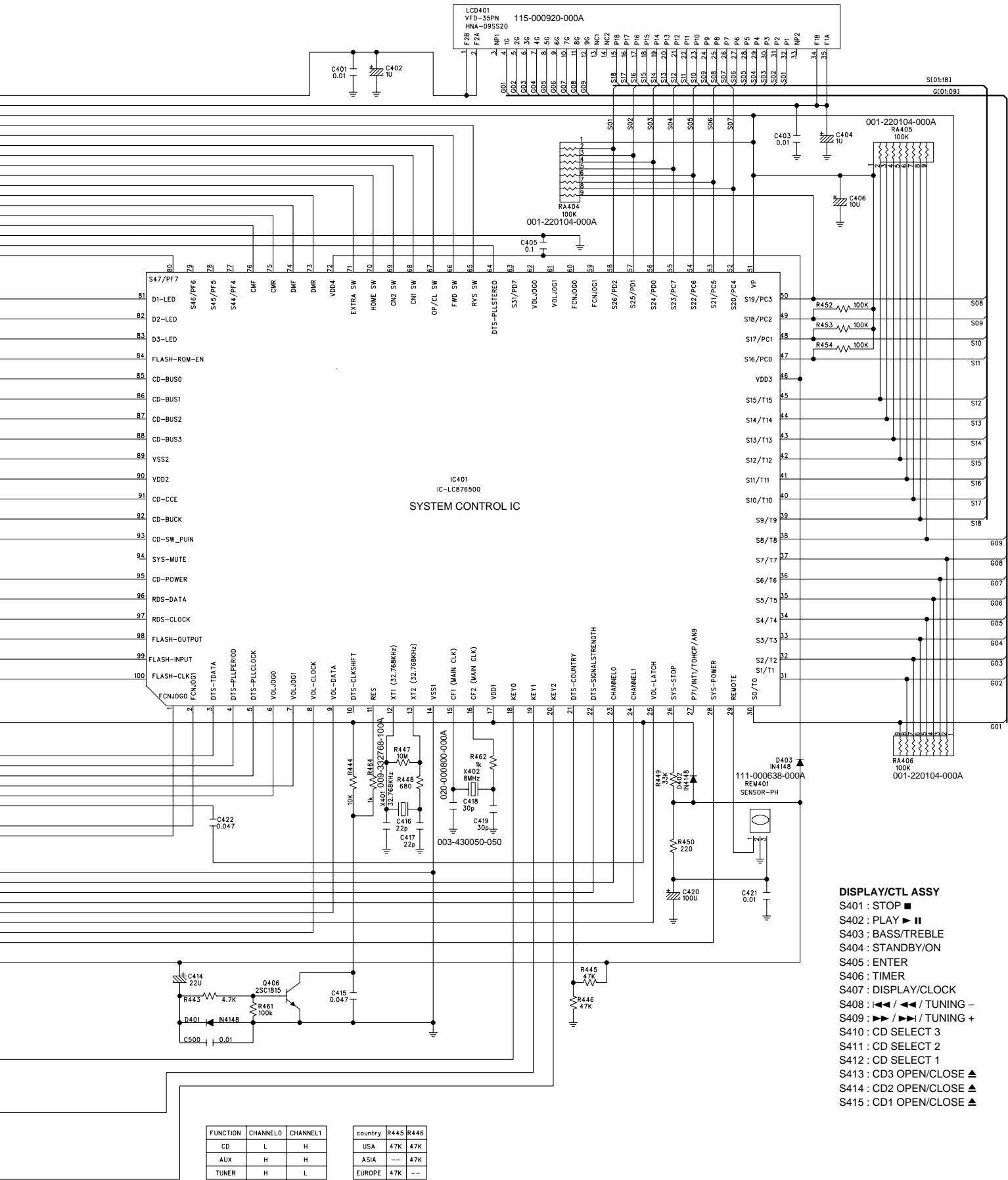

- DISPLAY/CTL ASSY**
- S401 : STOP ■
  - S402 : PLAY ▶▶
  - S403 : BASS/TREBLE
  - S404 : STANDBY/ON
  - S405 : ENTER
  - S406 : TIMER
  - S407 : DISPLAY/CLOCK
  - S408 : ◀◀ / ▶▶ / TUNING -
  - S409 : ▶▶ / ▶▶ / TUNING +
  - S410 : CD SELECT 3
  - S411 : CD SELECT 2
  - S412 : CD SELECT 1
  - S413 : CD3 OPEN/CLOSE ▲
  - S414 : CD2 OPEN/CLOSE ▲
  - S415 : CD1 OPEN/CLOSE ▲

FUNCTION	CHANNELO	CHANNEL1	country	R445	R446
CD	L	H	USA	47K	47K
AUX	H	H	ASIA	--	47K
TUNER	H	L	EUROPE	47K	--



# 4. PCB CONNECTION DIAGRAM

## NOTE FOR PCB DIAGRAMS :

- Part numbers in PCB diagrams match those in the schematic diagrams.
- The parts mounted on this PCB include all necessary parts for several destinations.
- For further information for respective destinations, be sure to check with the schematic diagram.
- View point of PCB diagrams.

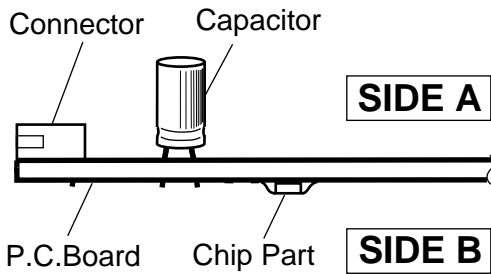

### 4.1 STD. TUNER ASSY

#### A STD. TUNER ASSY

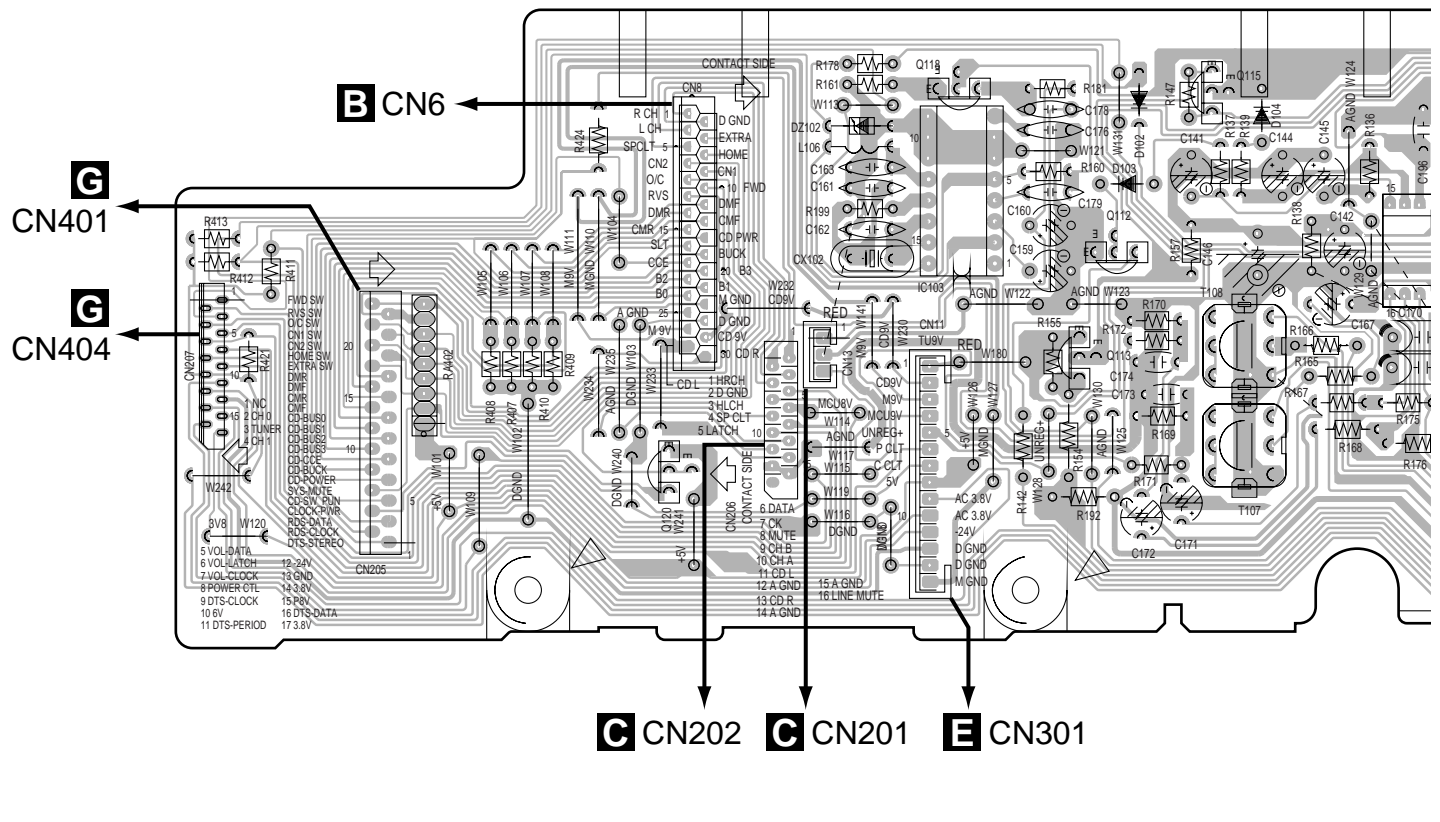

Q118 IC103  
Q112 Q115  
Q113

Q120

A

B

C

D

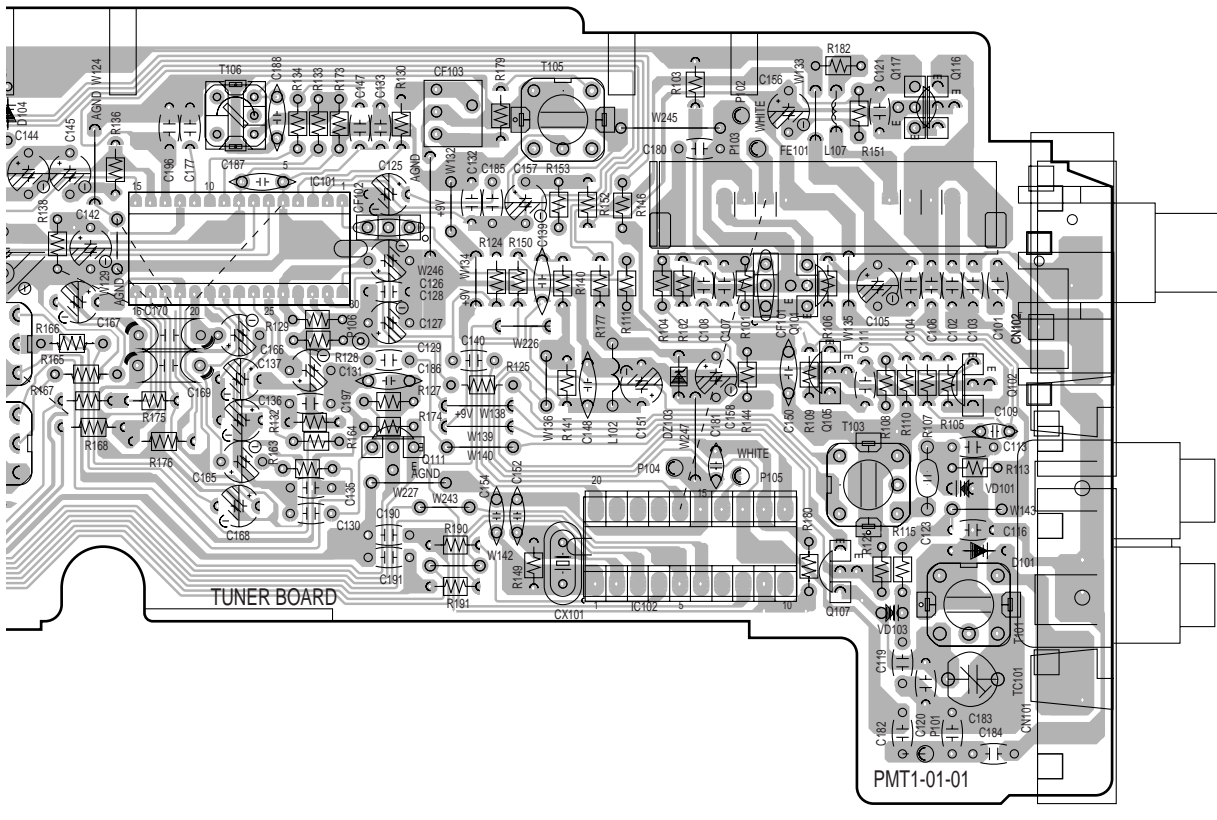

IC101

Q111

IC102

Q101

Q105  
Q107

Q117 Q116

Q102

**SIDE A**





**B** CD ASSY

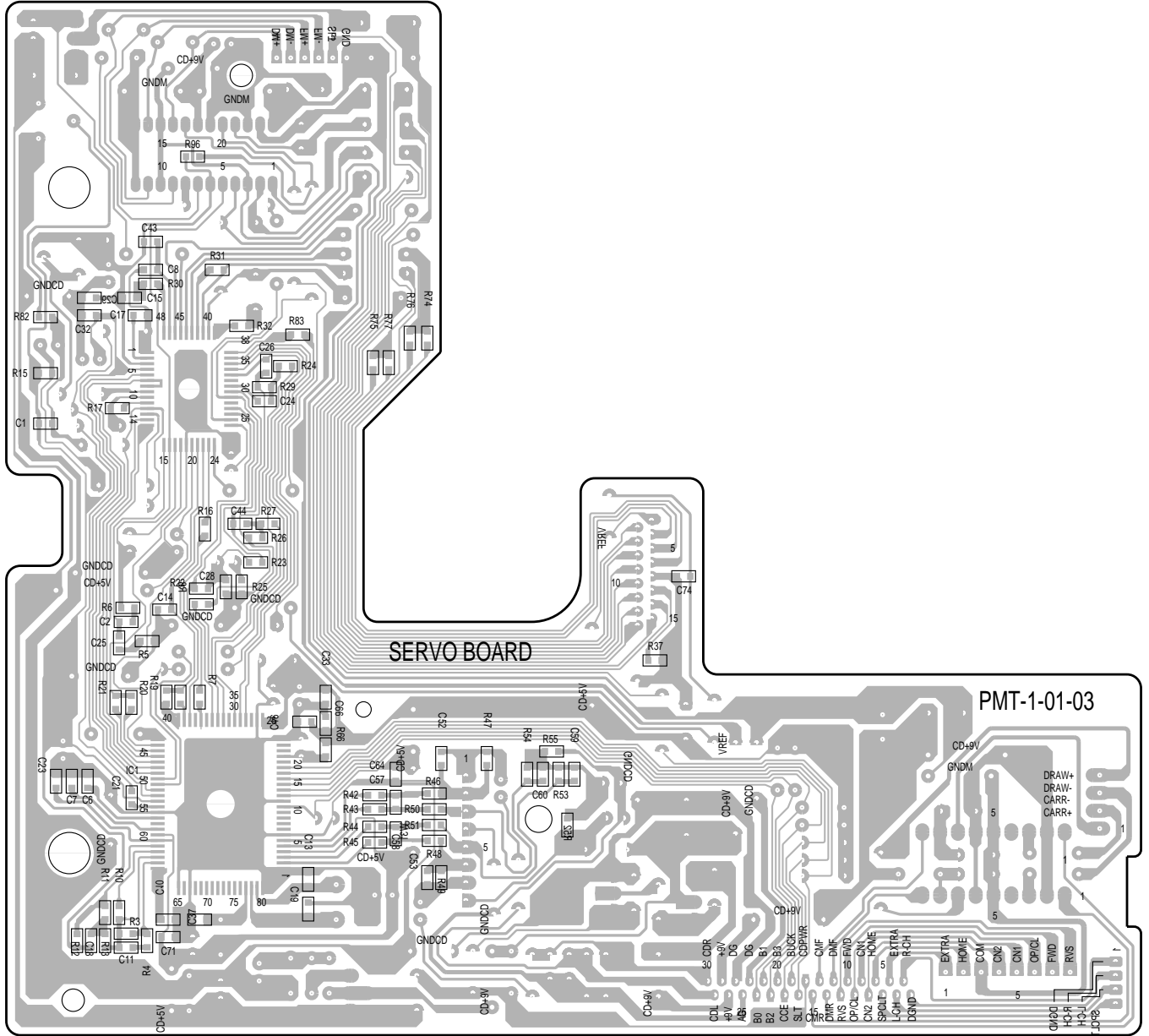

IC2  
IC1

**SIDE B**

4.3 AUDIO ASSY

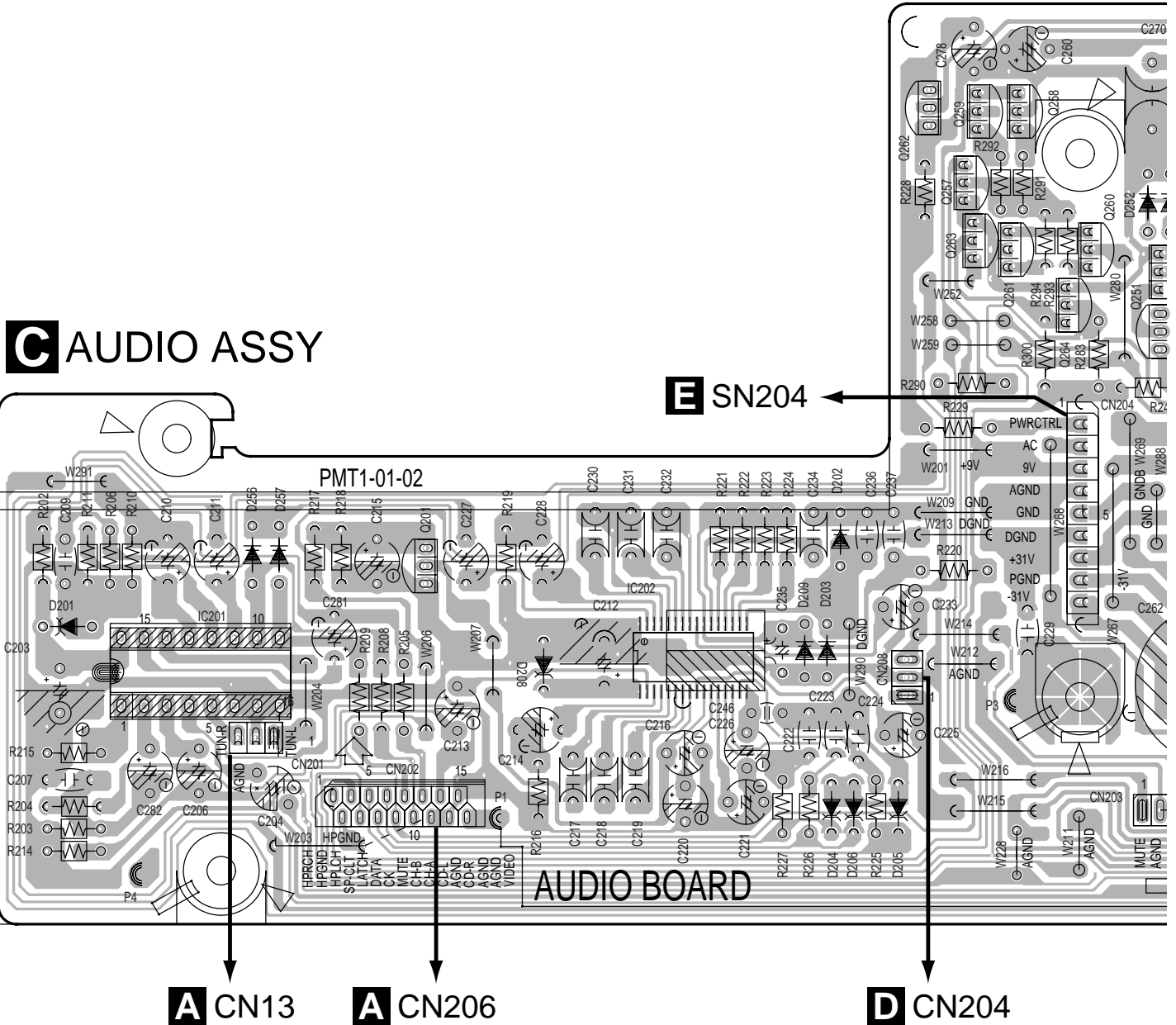



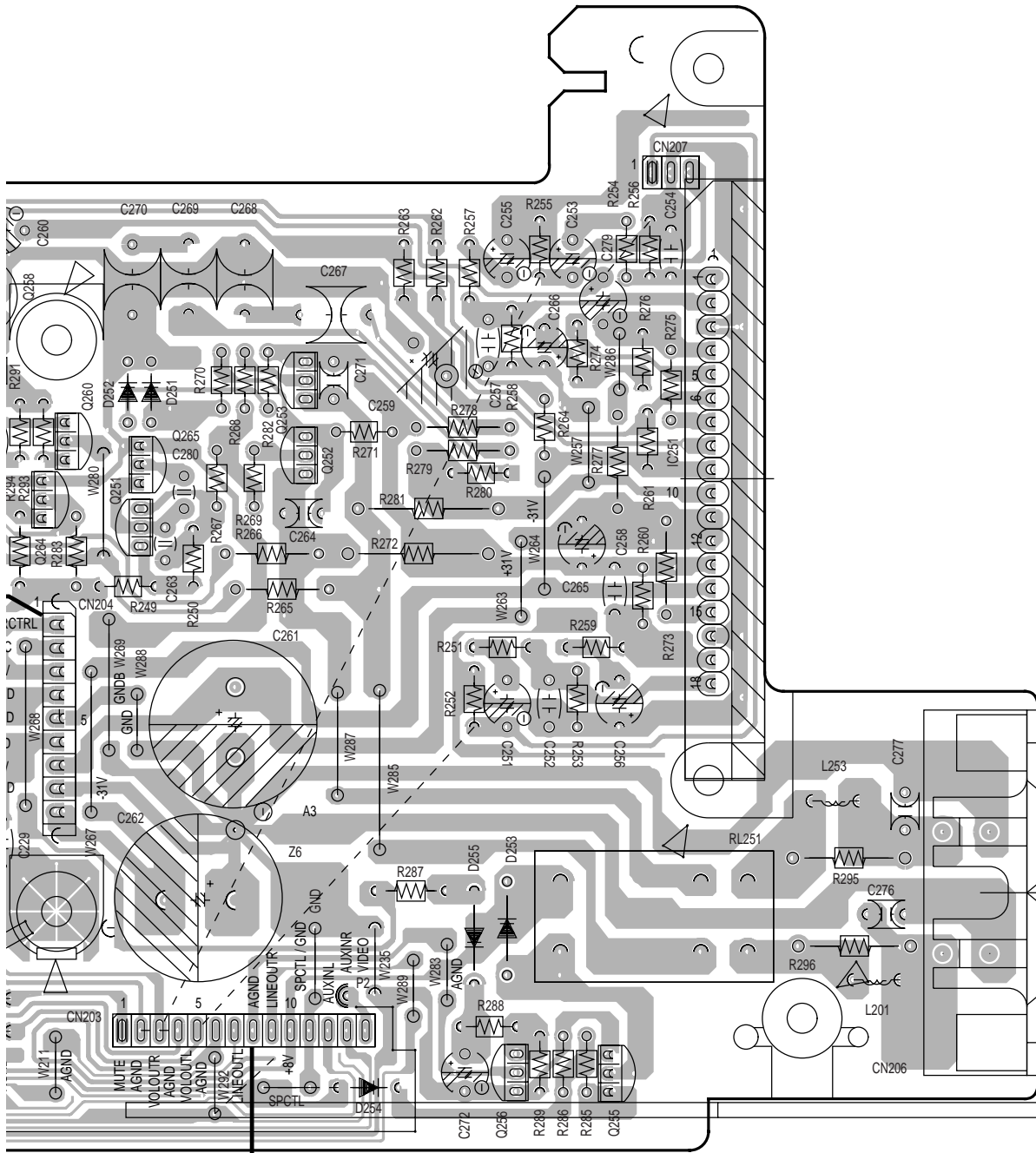

**D** J201

		Q253			
I	Q260	Q265	Q252	Q256	Q255
	Q264	Q251			

**SIDE A**

4.4 RECT and TRANS ASSYS

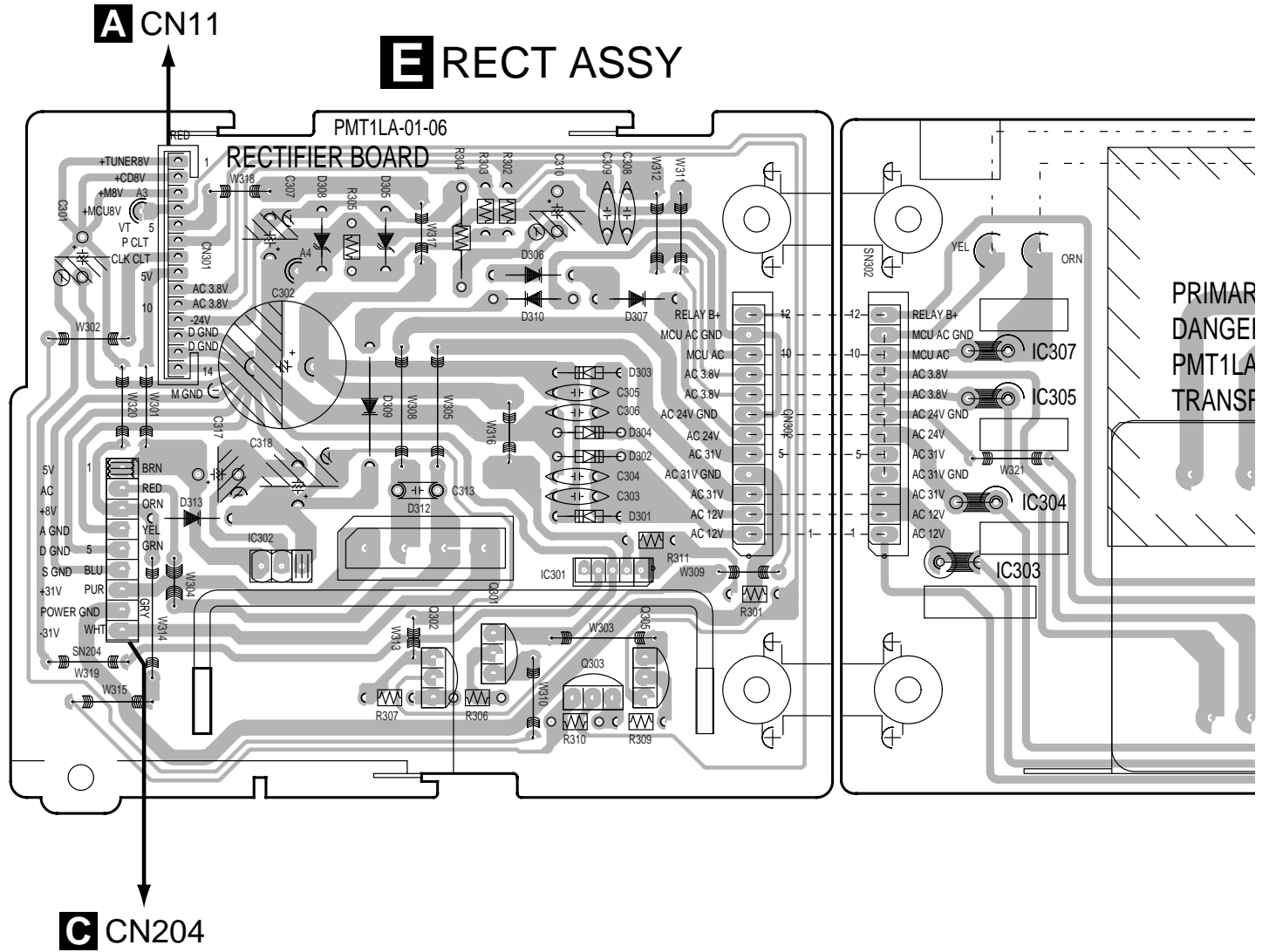

IC302

Q302

Q301

IC301  
Q303 Q306

IC307  
IC305  
IC304  
IC303

# F TRANS ASSY

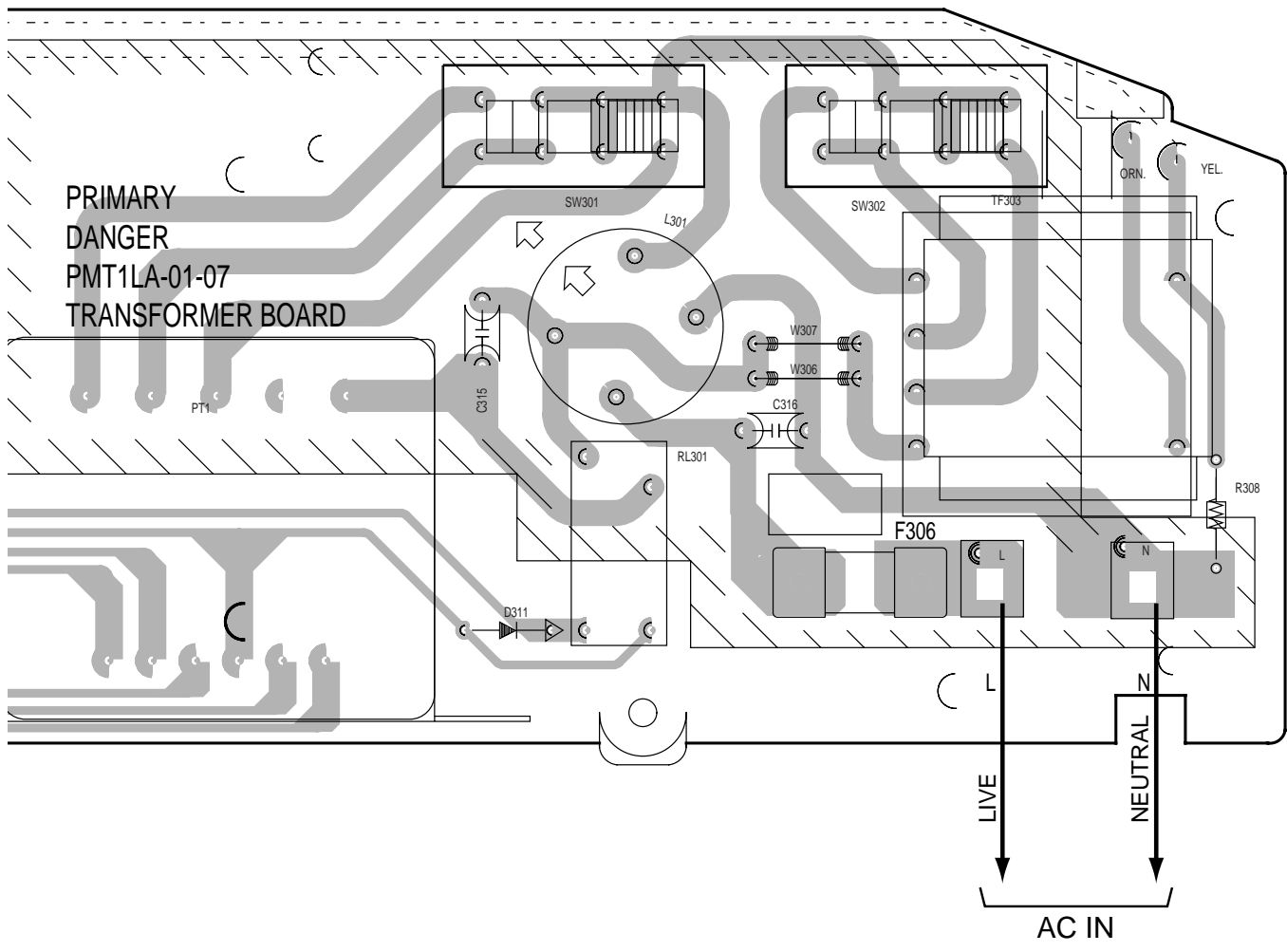

**SIDE A**

### 4.5 AUX ASSY

## D AUX ASSY

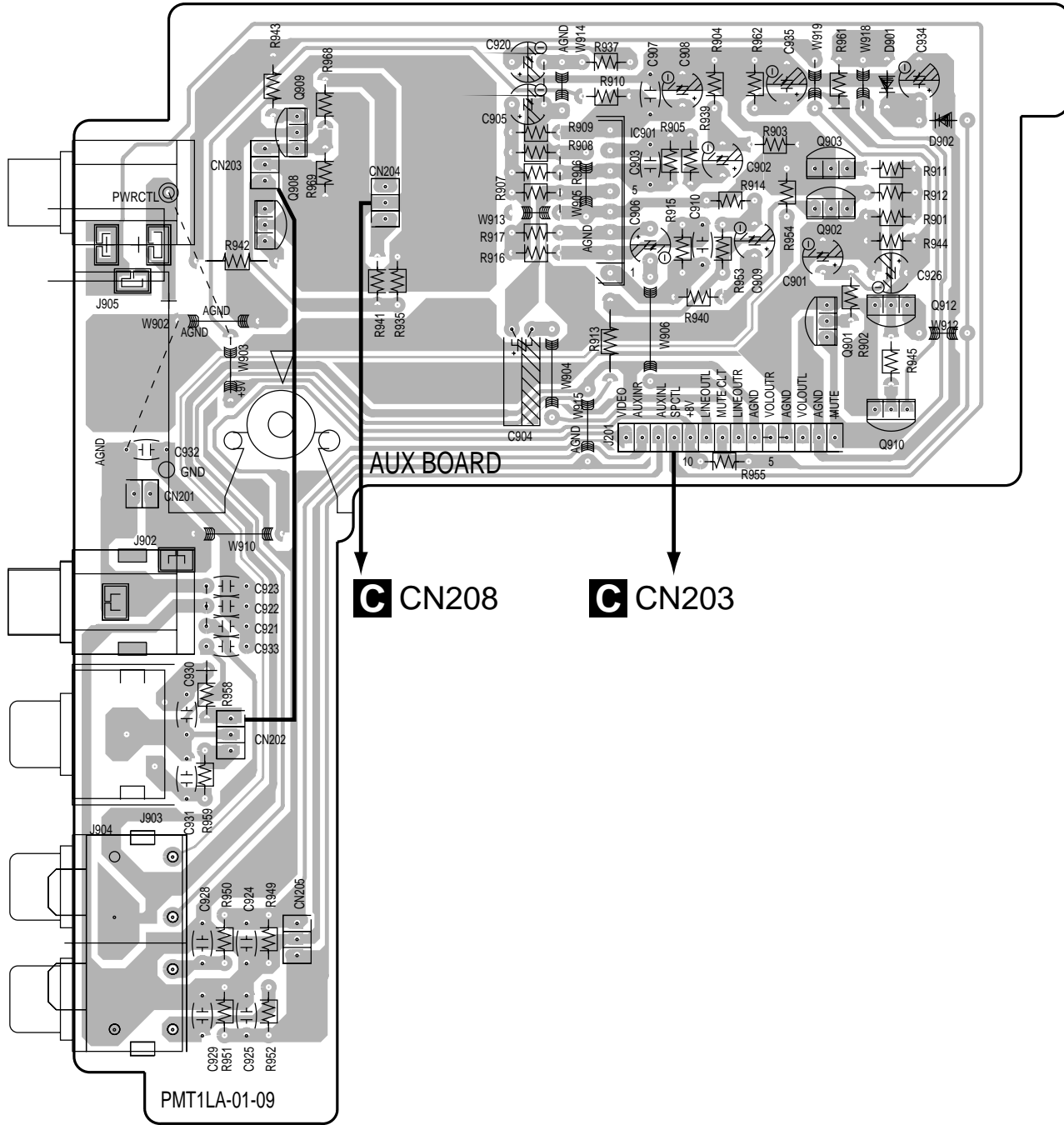

Q908 Q909

IC901

Q903  
Q902  
Q901

Q912  
Q910

SIDE A

4.6 DISPLAY/CTL ASSY

**G** DISPLAY/CTL ASSY

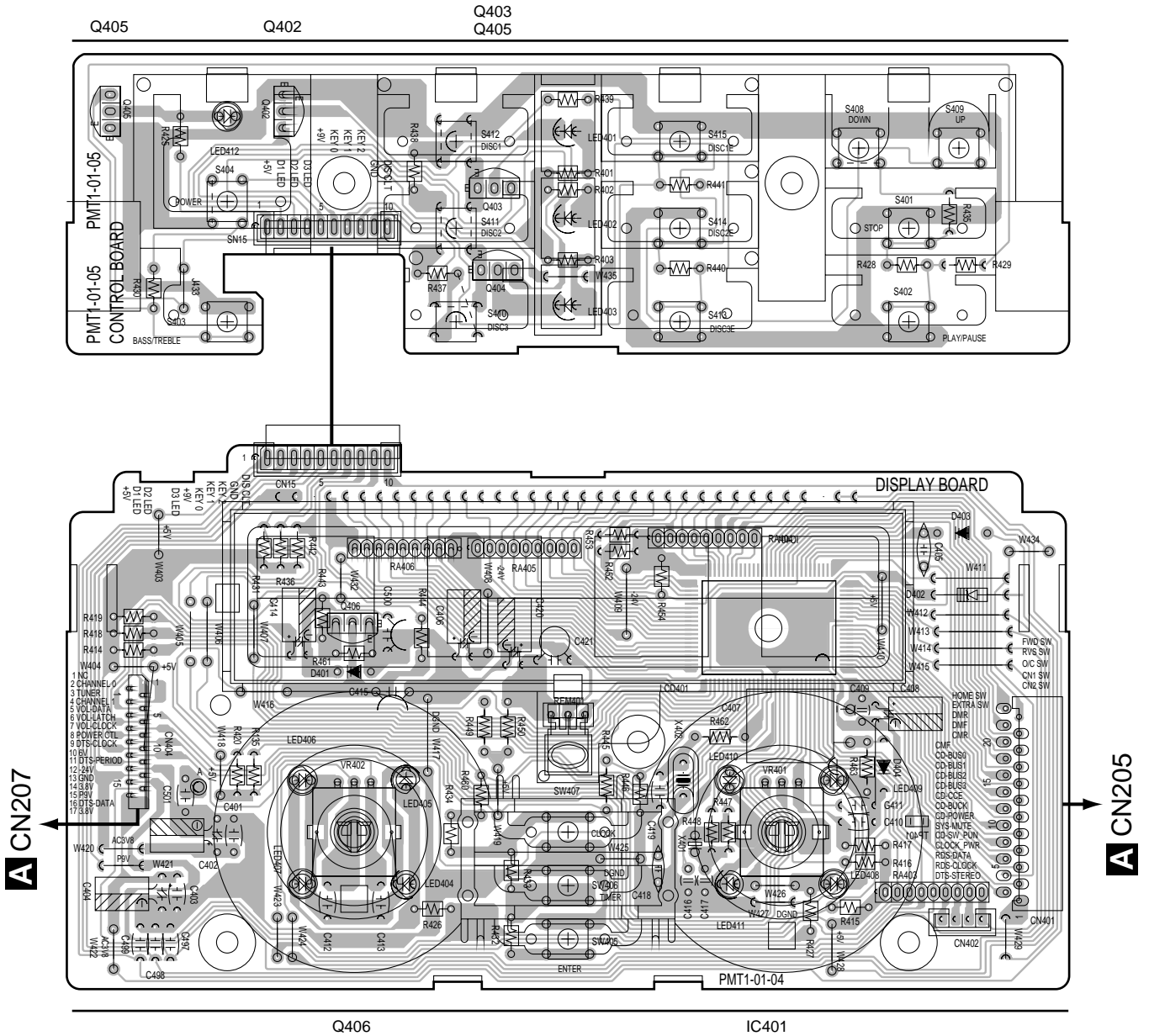

SIDE A

## 5. PCB PARTS LIST

NOTES: ●Parts marked by "NSP" are generally unavailable because they are not in our Master Spare Parts List.

●The Δ mark found on some component parts indicates the importance of the safety factor of the part.

Therefore, when replacing, be sure to use parts of identical designation.

●When ordering resistors, first convert resistance values into code form as shown in the following examples.

Ex.1 When there are 2 effective digits (any digit apart from 0), such as 560 ohm and 47k ohm (tolerance is shown by J=5%, and K=10%).

560 Ω → 56 × 10<sup>1</sup> → 561 ..... RD1/4PU 5 6 1 J  
 47k Ω → 47 × 10<sup>3</sup> → 473 ..... RD1/4PU 4 7 3 J  
 0.5 Ω → R50 ..... RN2H R 5 0 K  
 1 Ω → 1R0 ..... RSIP 1 R 0 K

Ex.2 When there are 3 effective digits (such as in high precision metal film resistors).

5.62k Ω → 562 × 10<sup>1</sup> → 5621 ..... RN1/4PC 5 6 2 1 F

Mark	No.	Description	Part No.	Mark	No.	Description	Part No.
------	-----	-------------	----------	------	-----	-------------	----------

### LIST OF PCB ASSEMBLIES

STD. TUNER ASSY	TUN-PMT1E-DL
CD ASSY	CD--PMT1E
AUDIO ASSY	PMT101000210
AUX ASSY	PMT1LA100091
RECT ASSY	PMT1LA100061
TRANS ASSY	PMT1LA100071
DISPLAY/CTL ASSY	PMT10100041

C146	CEAT221M10
C125	CEAT330M16
C126	CEAT3R3M50
C127	CEAT470M16
C167,C168,C165,C166	CEAT4R7M50
C144,C137	CEATR47M50
C133,C121	CGCYX104K25
C119	CKCYB682K50
C132,C111,C106-C109,C104,C180	CKCYF103Z50
C186-C188,C101	CKCYF103Z50
C169,C170	CQMBA273J50

### A STD. TUNER ASSY SEMICONDUCTORS

IC101(ICREVA-AFM-IF-MPX LA1837L)	010-101837-000A
IC102 (ICPLL TC9257P)	010-849257-001A
Q102,Q105 (TRANSISTOR 2SC1417)	008-314170-008A
Q113,Q115 (TRLPNPPWR 3CA8550)	008-685500-000A
Q120 (TR DTA114YS)	008-801144-000A
Q112,Q116,Q117	2SC1815
Q101,Q107	2SK161
D101-D104	1N4148
VD101,VD103	KV1561A-2
DZ103 (ZENER IN-5231B,HZ5C1)	011-010051-120A

### COILS AND FILTERS

L102 (INDUCTOR 100μH)	018-010014-000A
Δ L108 (BAD COIL #BA3534)	037-003534-100
CF102,CF101	019-000107-006A
CERAMIC FILTER SFE10	
CF103 (CERAMIC FILTER LTU450G2)	019-000450-012A

### CAPACITORS

C173,C174,C139,C103 (0.002μF)	003-020280-050
C177,C128,C129,C140,C185,C116	003-020380-050
C148,C150 (CERAMIC CAP 0.02μF)	003-020380-050
C154,C152 (CERAMIC CAP 24pF)	003-024010-050
C147 (CERAMIC CAP 0.04μF)	003-040380-050
C288,C183,C184 (CERAMIC 50pF)	003-050010-050
C135 (CERAMIC CAP 820pF/50V)	003-082110-050
C123 (POLY CAP 350pF/50V)	005-035100-000A
C113	CCCCH100D50
C190	CCCCH101J50
C101	CCCCH330J50
C156	CEAT100M50
C158	CEAT101M10
C171,C136,C141,C142,C145,C172	CEAT1R0M50
C131	CEAT220M25

### RESISTORS

RA402 (RESISTOR NETWORK 10kΩ)	001-229103-000A
Other Resistors	RD1/4PU <span style="border: 1px solid black; padding: 0 2px;"> </span> <span style="border: 1px solid black; padding: 0 2px;"> </span> <span style="border: 1px solid black; padding: 0 2px;"> </span>

### OTHERS

TC101	TRIMMER CAP CVN610-3	007-200610-000A
T107,T108	IFT PF120C 10mm	012-000120-010A
T105	IFT 4A-224R,10mm	012-002240-010A
T103	IFT 1A612R,10mm	012-006120-010A
T101	IFT 1A784R MW RF,10mm	012-007840-010A
T106	IFT FM DET 600TEAS	012-7NF803-007A
FE101	TUNER-FN&&&00STATION	042-104511-000A
P101	JP WIRE AWG26 110mm	051-675110-009J
	SHIELD WIRE SINGLE	053-103077-015J
CN101,CN102	EXT SP JACK	118-040102-002A
CN206	FFC CONN SOCKET 16P	135-006116-160J
CN8	FFC CONN 6232 30PINS	135-006232-300J
CN205	FFC CONN SOCKET 24P	135-FEBTVK-240J
CN207	FFC CONN SOCKET 17P	135-TOCB17-171J
CN13	HSG PMT1-3A PEC 2001H	136-03PMT1-B00J
CN11	HSG PMT1-14A PEC 2001H	136-14PMT1-B00J
CX101	CRYSTAL RESONATOR (7.2MHz)	009-607200-000A

### B CD ASSY SEMICONDUCTORS

IC2 (TA2065F)	010-832065-000A
IC3 (IC MOTOR DRIVER TA2092)	010-832092-000A
IC1 (TC9284BF)	010-849284-000A
IC4	BA4558N-HT
IC5,IC6	TA7291S

Mark	No.	Description	Part No.
	Q2	(TRLNPNPWR 3DA8050)	008-680500-000A
	Q1	(TRLNPNPWR 3CA8550)	008-685500-000A
	Q5		2SB562
	Q6		2SC1815
	D1-D3		1N4148
	Z1	(ZENER IN-5232B 5.6V)	011-010056-120A

**COILS**

	L1	(INDUCTOR 100μH)	018-010014-000A
△	L2	(BAD COIL #BA3534)	037-003534-100

**CAPACITORS**

	C13,C19,C43	(CHIP CAP 24pF/50V)	003-624052-050A
	C18		CCSRCH101J50
	C57,C58		CCSRCH121J50
	C52,C52,C59,C60		CCSRCH221J50
	C15		CCSRCH270J50
	C8		CCSRCH4R0C50
	C37,C68,C12,C20		CEAT100M50
	C34,C38,C40,C45,C61,C62,C54		CEAT101M10
	C65		CEAT101M10
	C42		CEAT102M10
	C9		CEAT1R0M50
	C27		CEAT220M25
	C46,C48		CEAT221M10
	C16,C31,C29		CEAT470M16
	C72		CEAT471M10
	C56,C55		CEAT4R7M50
	C51		CEJQ101M10
	C75		CEJQ470M16
	C41,C4,C35,C22,C36		CGCYX104M16
	C73,C47		CKCYF103Z50
	C10,C11,C33,C74		CKSRYB103K50
	C23,C24,C28,C64,C66,C69		CKSRYB104K16
	C44		CKSRYB153K50
	C26		CKSRYB223K50
	C7,C6		CKSRYB332K50
	C1		CKSRYB471K50
	C21		CKSRYB472K50
	C17,C30,C32,C3		CKSRYB473K16
	C2		CKSRYB563K16
	C14		CKSRYB682K50
	C25		CKSRYF333Z50

**RESISTORS**

	R34		RD1/4PM100J
	R41		RD1/4PU101J
	VR2-VR4	FEO,TEB,TEO (100kΩ)	002-104085-102A
	VR1	FEB (5kΩ)	002-472065-000A
	Other Resistors		RS1/16S□□□□

**OTHERS**

	CN6	FFC CONN 6232 30P	135-006232-301J
	CN3	FFC CONN SOCKET 16P	135-TOCA16-160A
	CN1	HSG 5CD1-4B JST	136-045CD1-201J
	CN5	HSG PMT1-4A JST	136-04PMT1-250J
	CN4	HSG 2CD9-6C (REV)	136-067238-205J
	CN2	HSG PMT1-8A JST SOLDERING PIN	136-08PMT1-250J 137-300000-002J
	X1	CERAMIC RESONATOR (16.93MHz)	020-001693-000A

Mark	No.	Description	Part No.
<b>C</b>	<b>AUDIO ASSY</b>		
	<b>SEMICONDUCTORS</b>		

	IC201		BU4052BC
	IC202		BH3854FS
	Q201		2SC1815
	D201		MTZJ4.7B
	D202, D203		1N4148
	D204-D206	(ZENER 05AZ4.7)	011-010051-121A
	D209		MTZJ9.1B
	D255	(RECTIFIER IN-4001B)	011-024001-000A

**CAPACITORS**

	C203		CEAT221M16
	C206, C204, C210, C211, C215		CEAT4R7M50
	C225, C233, C281, C282		CEAT4R7M50
	C207, C209, C222, C223, C224		CKCYB101K50
	C212, C235		CEAT471M16
	C213, C227		CEAT1R0M50
	C214, C221, C228		CEAT220M25
	C216		CEAT100M50
	C217, C218, C230, C231	(MYLAR CAP 0.068 uF/100V)	004-068350-100
	C219, C232	(MYLAR CAP 0.047 uF/50V)	004-010310-100
	C220		CEATR22M50
	C226		CEAT101M10
	C229, C236, C237		CGCYF104Z25
	C234	(MYLAR CAP 0.022uF/100V)	004-022310-100
	C246		CKCYF473Z50
	C272		CEAT2R2M50

**RESISTORS**

	All Resistors		RD1/4PU□□□□
--	---------------	--	-------------

**OTHERS**

	P3,P4	ROUND PIN	137-500001-000J
	CN201	HEADER CTL 3 PINS	135-PHS030-030J
	CN202	FFC CONN SOCKET 16P	135-006116-160J
	CN204	HEADER 4 PINS	135-005267-090J

**D AUX ASSY**  
**SEMICONDUCTORS**

	IC901		BA4558DX
	Q912, Q910, Q901	(DTA114YS)	008-801144-000A
	Q903, Q902, Q908, Q909		2SD1468S
	D901, D902		1N4148

**CAPACITORS**

	C902, C909		CEAT1R0M50
	C903, C910, C924, C925, C928		CKCYB101K50
	C929, C930, C931		CKCYB101K50
	C904, C906, C934		CEAT4R7M50
	C905, C908		CEAT101M10
	C907	(CERAMIC CAP 0.02μF)	003-020380-050
	C921, C922, C933		CKCYF102Z50
	C935		CEAT3R3M50

**RESISTORS**

	All Resistors		RD1/4PU□□□□
--	---------------	--	-------------



# XC-LA21

Mark	No.	Description	Part No.
<b>OTHERS</b>			
		CONN PIN 3 PINS	050-030160-200J
	J201	CONN PIN 14 PINS	050-140060-200J
	GND	JP WIRE AWG22 140MM	051-275140-009J
	J904	RCA JACK HSP-244V-01	118-000244-000A
	J903	RCA JACK,HSP-202V-01	118-020202-000A
	J905	POWER JACK DC	120-100470-000
	CN204	HSG CD189D-3A	136-03189D-200J

## **E** RECT ASSY

### CAPACITORS

△	IC301 (IC REGULA BA09ST)	010-400009-001A
△	IC302	NJM78M56FA
△	Q302, Q303 (TRLNPPWR 3CA8550)	008-685500-000A
	Q305, Q301	DTC114ES
△	D301-D304	011-020005-000A
△	D305 (ZENER IN-5237B,8.2V)	011-010082-120A
△	D307, D306, D310, D309, D313 (RECTIFIER IN-4001B)	011-024001-000A
△	D308 (ZENER BZX55C24 24V)	011-010240-120A

### CAPACITORS

C301, C317	CEAT221M16
C302	CEAT222M25
C303-C306, C308, C309	CKCYF103Z50
C307	CEAT101M35
C310	CEAT101M50
C318	CEAT102M16

### RESISTORS

R304	RS1/2LMF221J
Other Resistors	RD1/4PU□□□□

### OTHERS

P301	JP WIRE AWB22#1007	051-275120-009J
	JP WIRE AWG26#1007	051-675300-010J
CN204	HSG PMT1-9A	136-09PMT1-C00J
CN301	HEADER 14 PINS	135-2001WS-140J
CN302	CONN PIN 12 PINS	050-120060-251J

## **F** TRANS ASSY

### SEMICONDUCTORS

△	F304, F305, F307 (IC MICRO FUSE 251001 1A)	124-010010-002A
△	F303 (IC MICRO FUSE #25103.5-TS2 3.5A)	124-035010-000A
△	D311 (RECTIFIER IN-4001B)	011-024001-000A

### COIL

△	L301 AC LINE FILTER	019-500160-000A
---	---------------------	-----------------

### SWITCHES AND RELAYS

△	SW301, SW302 SLIDE SW (VOLT.SELECTOR 117-220V)	025-230041-000A
△	RL301 (RELAY 9V SDT-S-109LMR)	128-090109-000A

### CAPACITORS

△	C315, C316 (CERAMIC CAP 0.01 uF/250V)	003-010320-250A
---	---------------------------------------	-----------------

Mark	No.	Description	Part No.
<b>OTHERS</b>			
		JP WIRE AWG22#UL1672	051-265160-003J
		JP WIRE AWG22 YELLOW	051-265180-010J
		AC CONTACT TERMINAL	137-400001-000J
F306		FUSE HOLDER 7900	550-790000-000J

## **G** DISPLAY/CTL ASSY

### SEMICONDUCTORS

IC401	PDA068A
Q402-Q405	DTC114ES
Q406	2SC1815
D402, D403, D401, D404	1N4148
LED401-LED403 (LED-Y-3MM)	110-033045-013A
LED412 (LED-R-3MM)	110-033040-013A
LED404-LED411 (LED-BL-3MM)	110-033162-003A

### SWITCHES

S401-S404, S408-S415	021-114165-000A
SW405-SW407 (F021-KHH902-001) TACT SW	021-114165-000A

### CAPACITORS

C401, C403, C497, C498, C499	CKCYF103Z50
C412, C413, C421, C410, C411, C500	CKCYF103Z50
C402, C404	CEAT1R0M50
C405, C495	CGCYX104M16
C406	CEAT100M50
C407 (ELECT CAP 47000MFD/5.5V)	006-747300-05CA
C414	CEAT220M25
C415, C409, C422	CKCYF473Z50
C416, C417	CCCCH220J50
C419, C418 (CERAMIC CAP 30pF/50V)	003-430050-050
C420, C408	CEAT101M10

### RESISTORS

RA404-RA406 (RESISTOR NETWORK100K)	001-220104-000A
RA403 (RESISTOR NETWORK EXB)	001-229103-000A
VR401, VR402 (ROTARY ENCORDER)	030-H12203-204A
Other Resistors	RD1/4PU□□□□J

### OTHERS

CN15	CONN PIN 10 PINS	050-100050-201J
	JP WIRE AWB22#1007	051-275120-009J
REM401	(REMOTE/CONTROL PHOTO RECEIVER)	111-000638-000A
LCD401	VACUUM FLUORESCENT	115-000920-000A
CN401	FFC CONN SOCKET 24P	135-FESTVK-240J
CN404	FFC CONN SOCKET 17P	135-TOCB17-171J
X401	CRYSTAL RESONATOR (32.768kHz)	009-332768-100A
X402	CERAMIC RESONATOR (8MHz)	020-000800-000A







## 6. ADJUSTMENT

### 6.1 CD SECTION

CD ASSY is taken out according to the procedure of DISASSEMBLY. And, please adjust the part CD after connecting connectors.

#### 6.1.1 PREPARATIONS

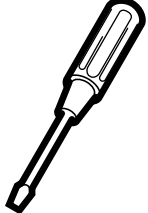
##### (1) Jigs and Measuring Instruments

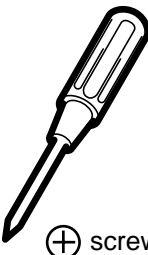
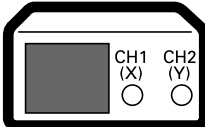
 <p>CD TEST DISC (YEDS-7)</p>	 <p>⊖ Precise screwdriver</p>	 <p>⊖ screwdriver (small)</p>	 <p>⊕ screwdriver (medium)</p>
 <p>⊕ screwdriver (large)</p>	 <p>Dual-trace oscilloscope (10 : 1 probe)</p>		

##### (2) Necessary Adjustment Points

When	Adjustment Points
Exchange PICKUP	1, 2, 3, 4 → Pages 35 and 36
Exchange CD ASSY	1, 2, 3, 4 → Pages 35 and 36
Exchange SERVO MECH ASSY	1, 2, 3, 4 → Pages 35 and 36

### 6.1.2 Adjustment

#### (1) Adjustment Locations

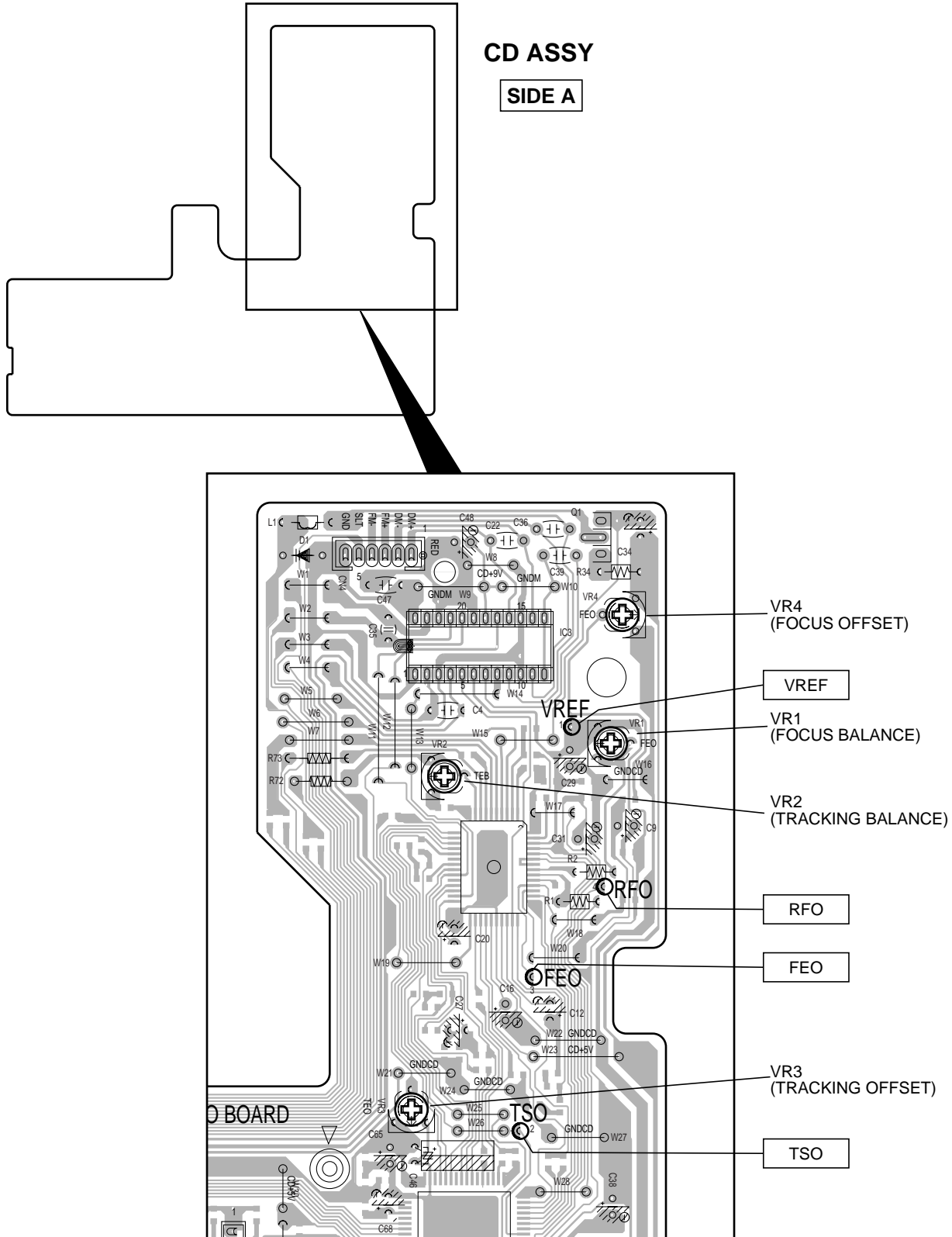
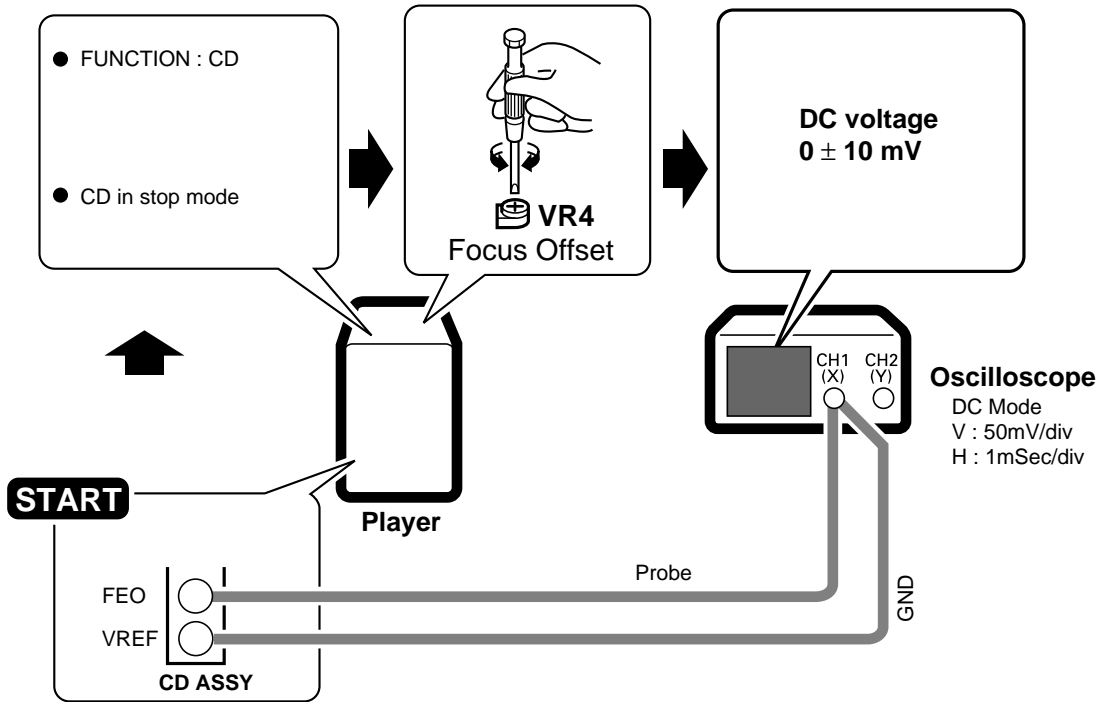

Fig. 1 Adjustment Locations

(2) Check and Adjustment

1. Focus Offset (FEO) Adjustment



2. Tracking Offset (TEO) Adjustment

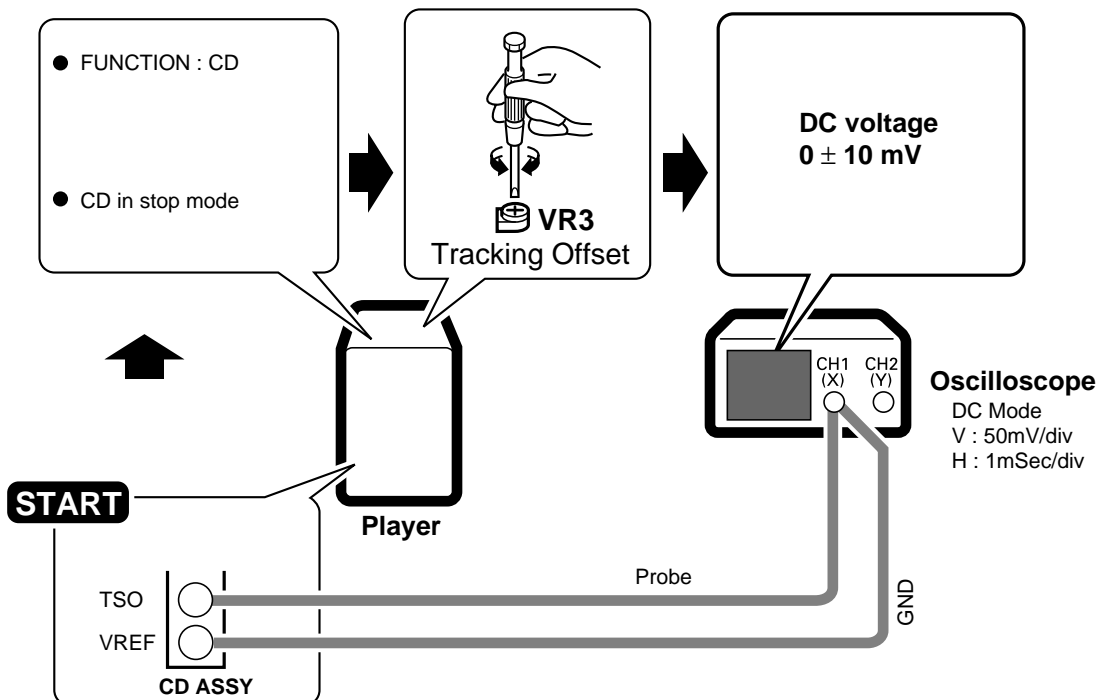

### 3. Tracking Balance (TEB) Adjustment

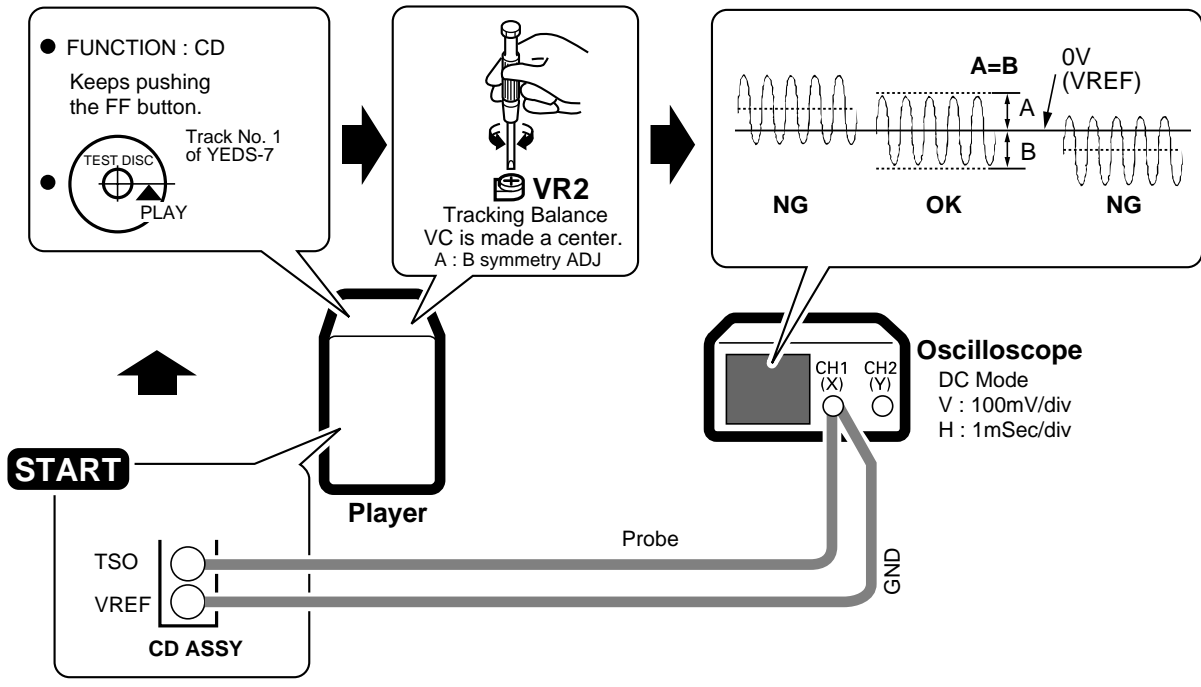

### 4. Focus Balance (FEB) / eye pattern (RF level) Adjustment

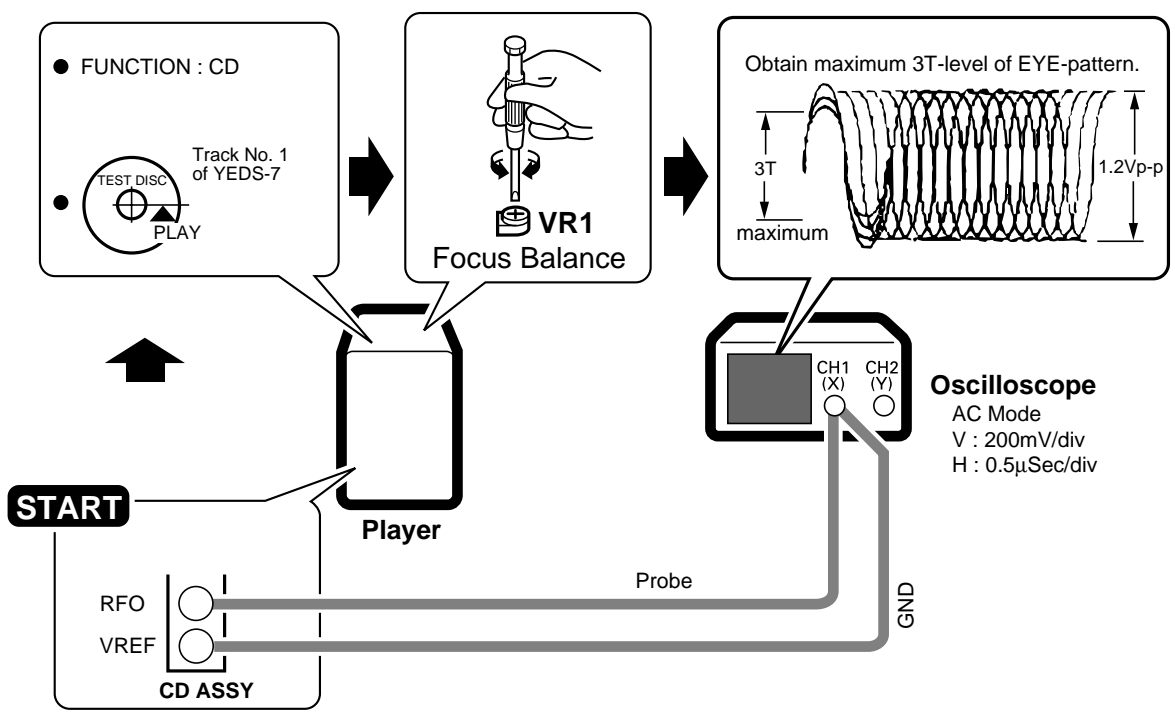

## 7.1 GENERAL INFORMATION

### 7.1 DIAGNOSIS

#### 7.1.1 TROUBLE SHOOTING

##### 1. Troubleshooting

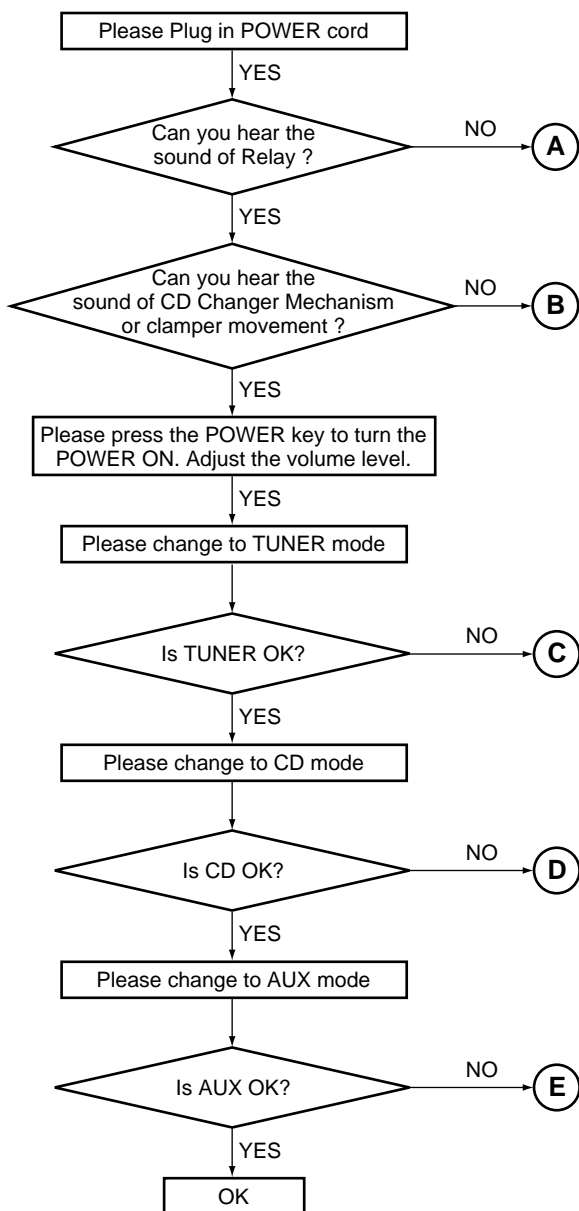

##### 2. Cannot hear the sound of relay when power cord plug in

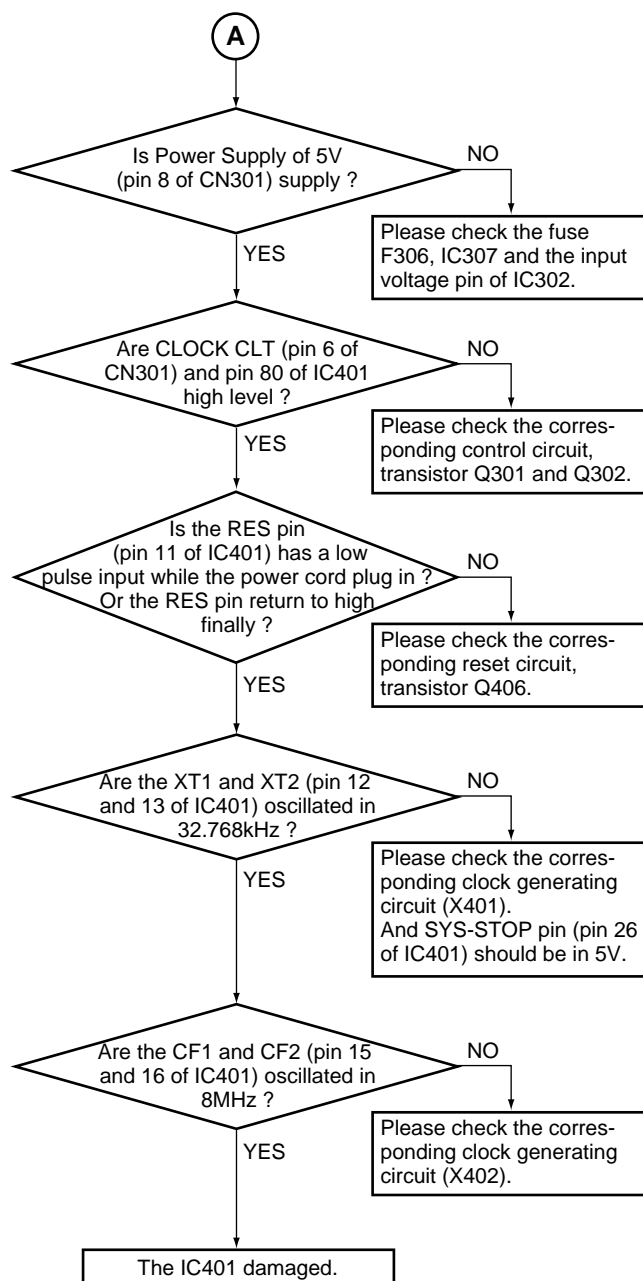

### 3. Can you hear the sound of CD Changer Mechanism or clamper movement when power cord plug in

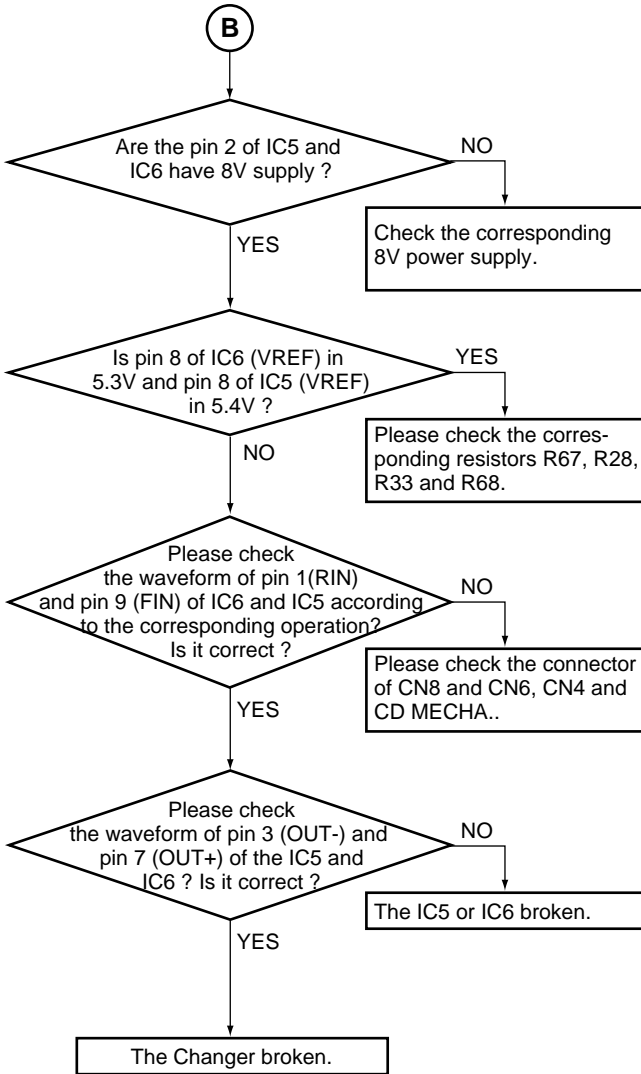

### 4. Tuner troubleshooting

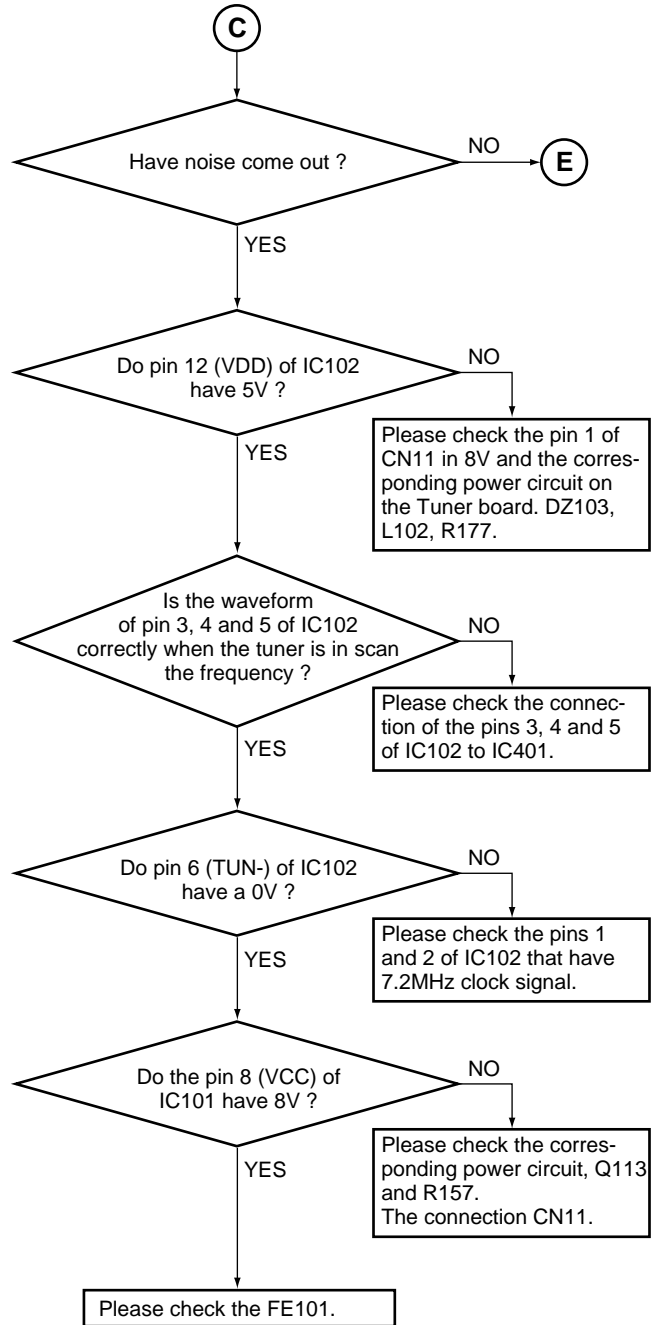

5. CD troubleshooting

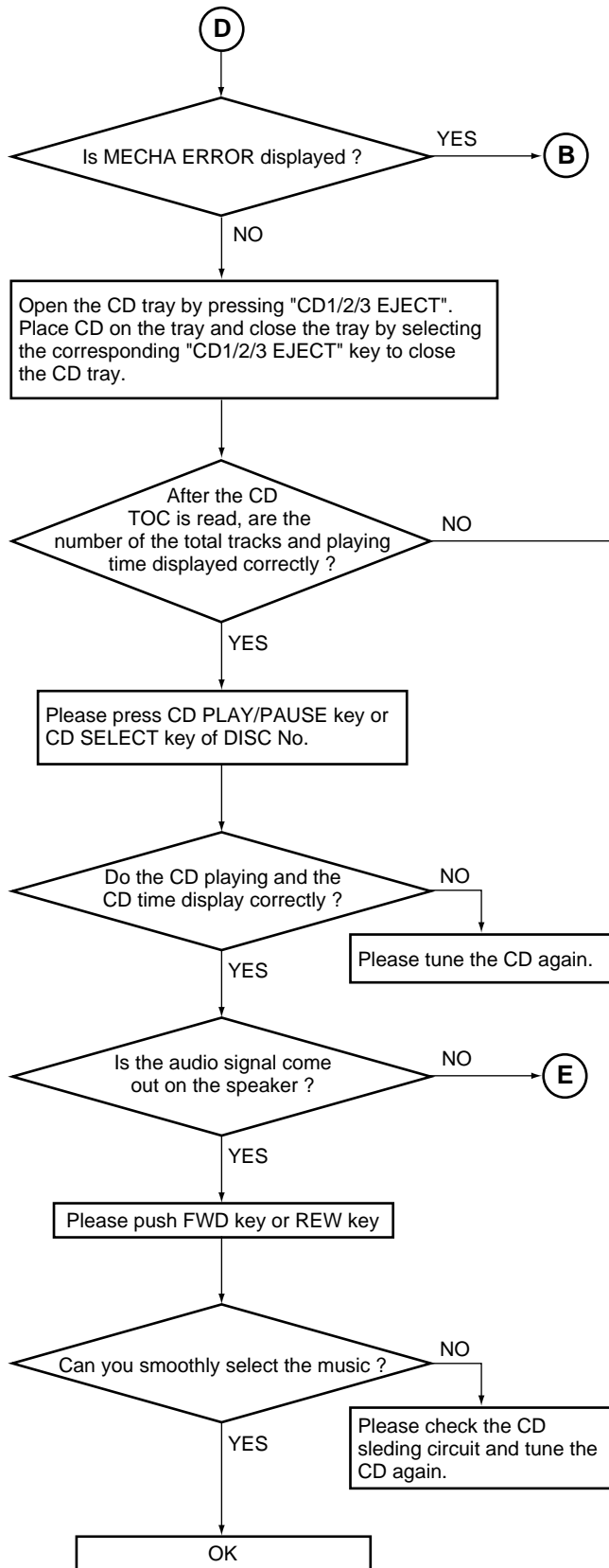

• The total track number is incorrectly displayed

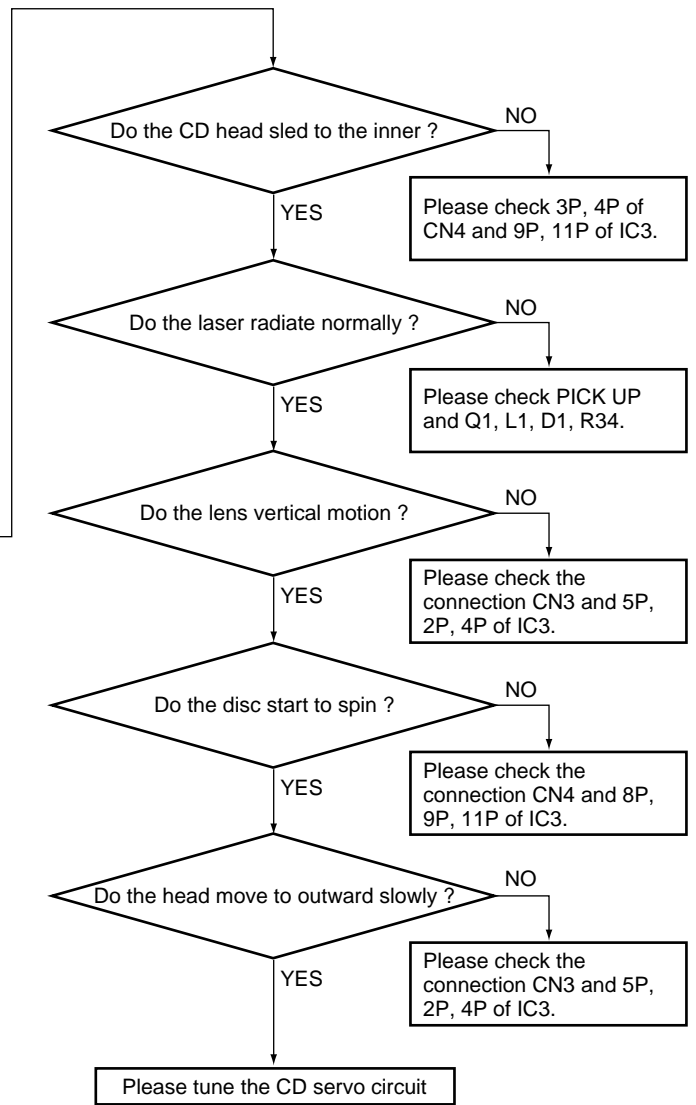

6. No audio signal come out on speaker

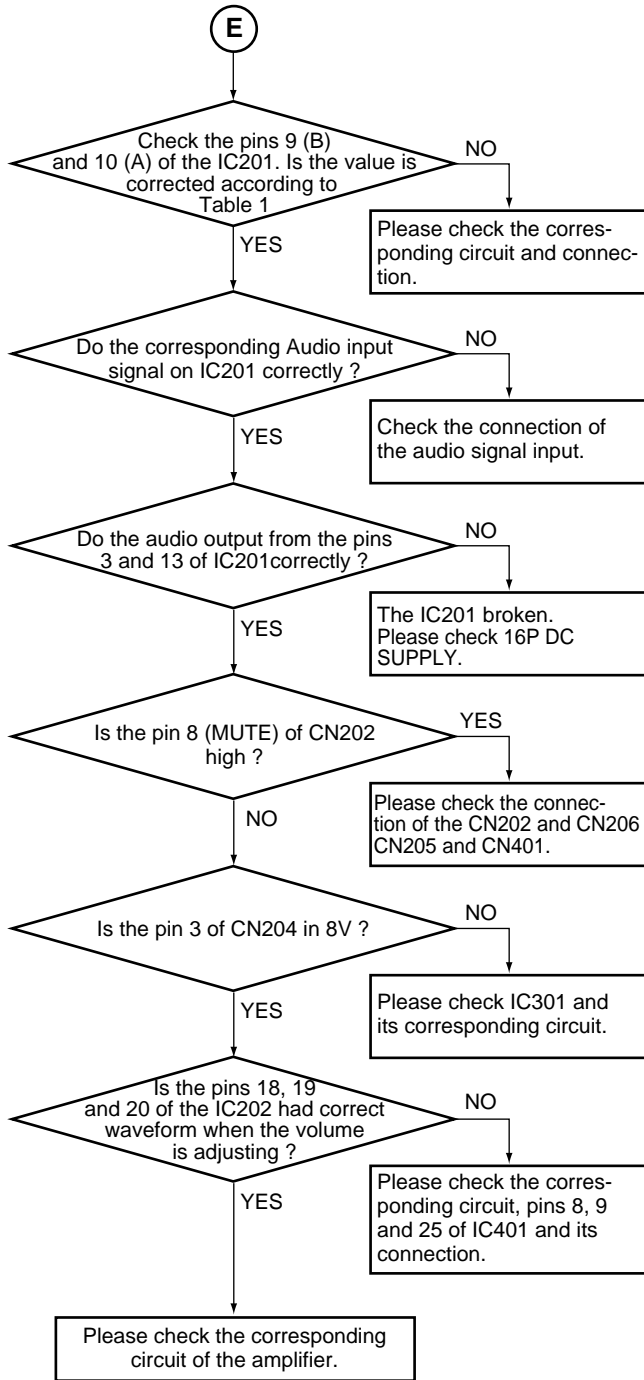

Table 1

Channel	(B) Pin 9 of IC201	(A) Pin 10 of IC201
Power OFF	0	0
Tuner	0	1
CD	1	0
AUX	1	1



## 7.1.2 DISASSEMBLY/ASSEMBLY

### (1) Main Body Section

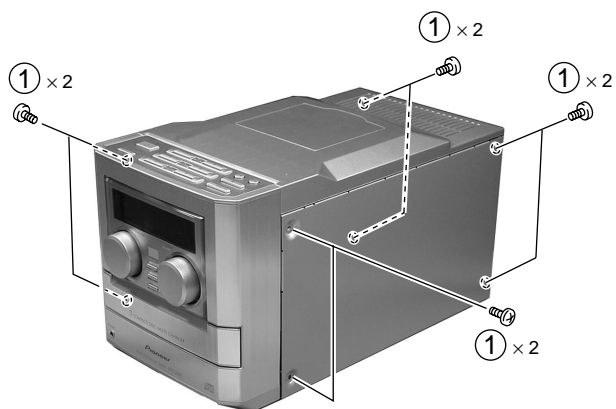

Side Panel L  
(Remove as well as Side Panel R)

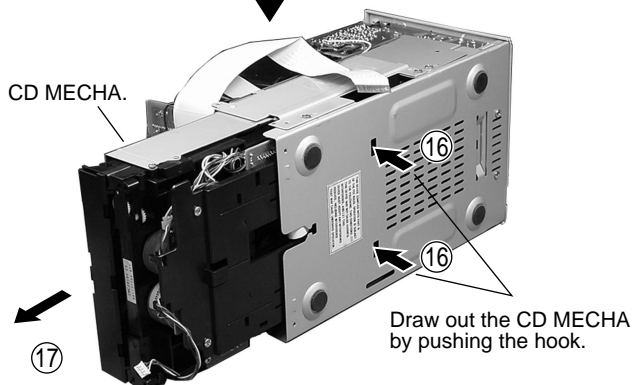
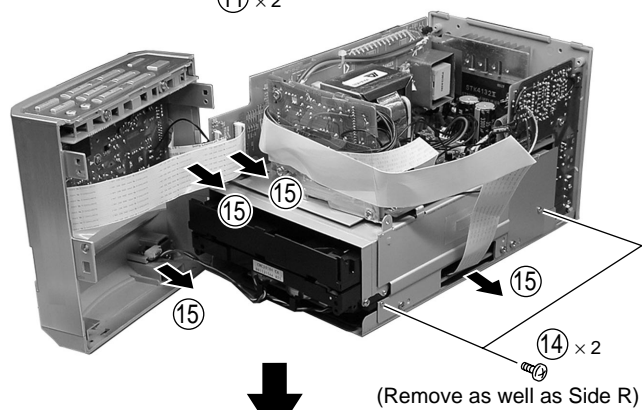
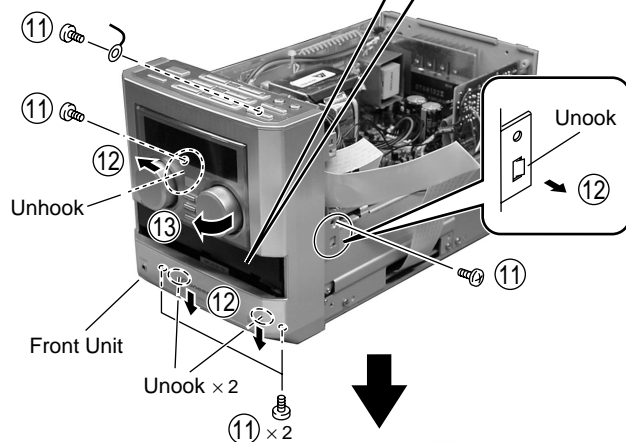
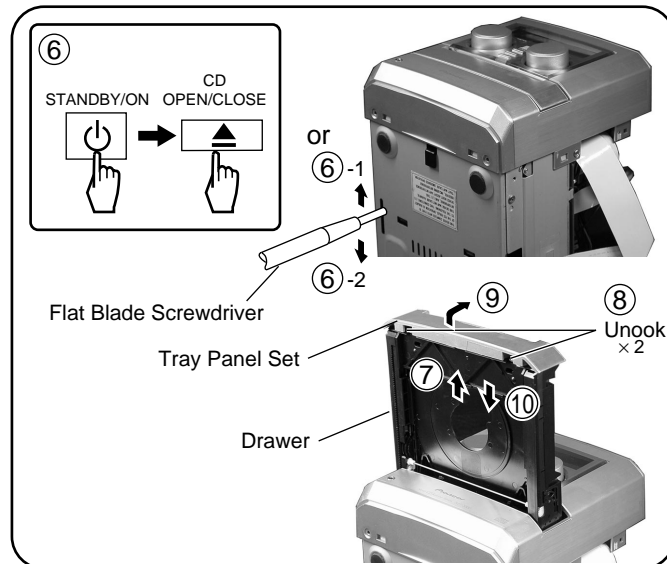
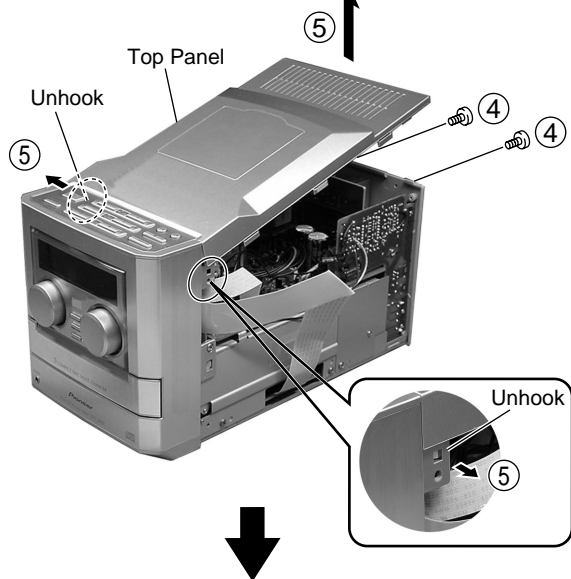

## (2) CD MECHA.

### CAUTION

- If Tray Panel Set is not detached when the CD MECHA. is repaired, the CD MECHA. cannot be removed from the main body of the product.  
When Drawer was not able not to open and shut by some something wrong's (The power supply does not enter, etc.) occurring, and remove Tray Panel Set, Slider 2 of the CD MECHA. is moved from the ditch of the chassis on the bottom side of the product with a minus driver and Drawer is drawn out. Afterwards, please remove Front Unit after removing Tray Panel Set .

### ■ Pickup Unit

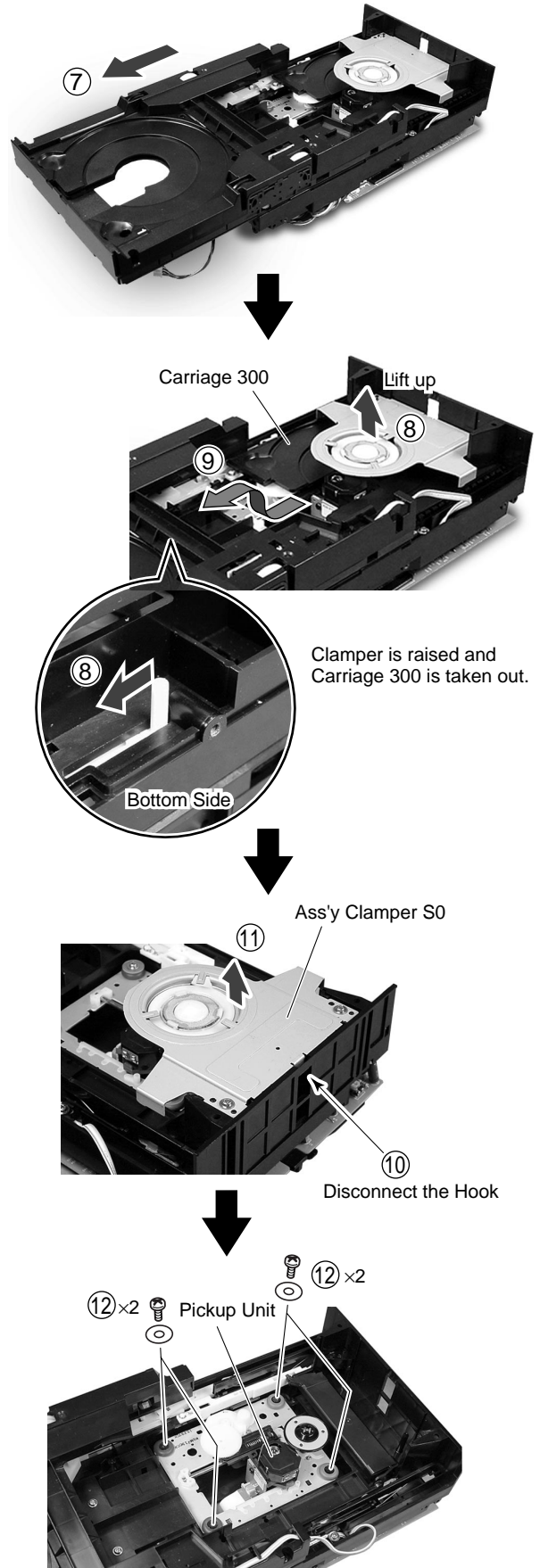
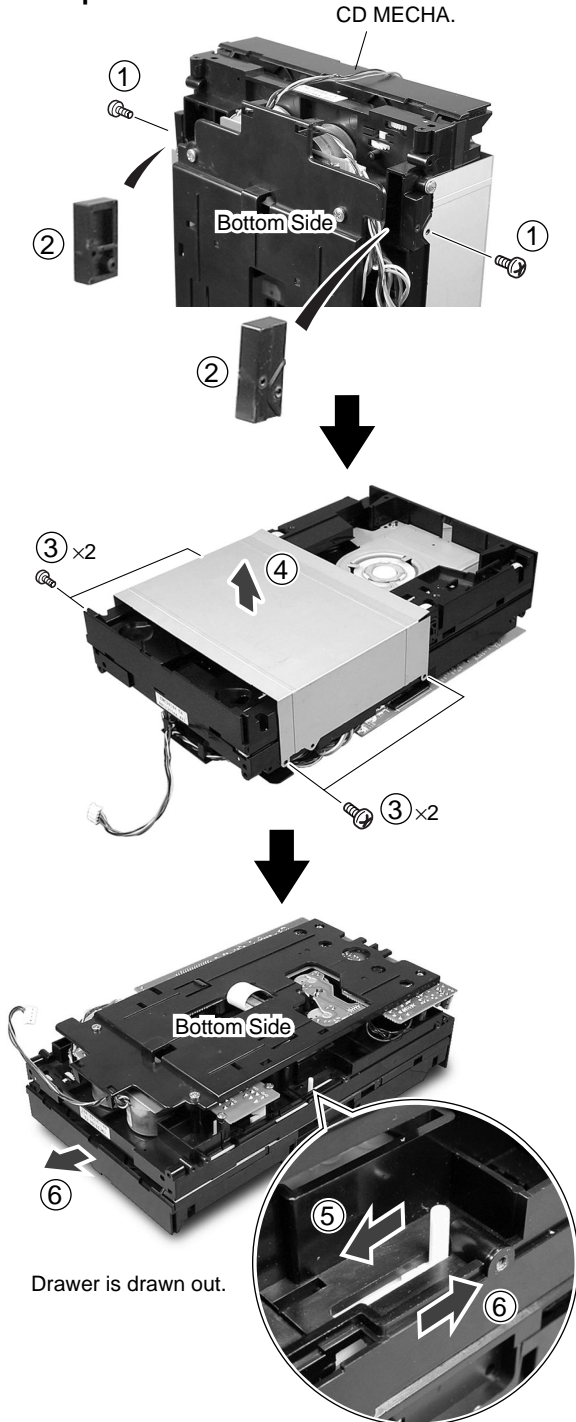

**Caution for Disassembly/Assembly of CD MECHA.**

1. As for the distinction method of Carriage 100, 200, and 300, Switch distinguishes the shape of the projection part on its back. Please confirm the number seal pasted to the surface of Carriage and the projection shape of the figure below when you exchange it.

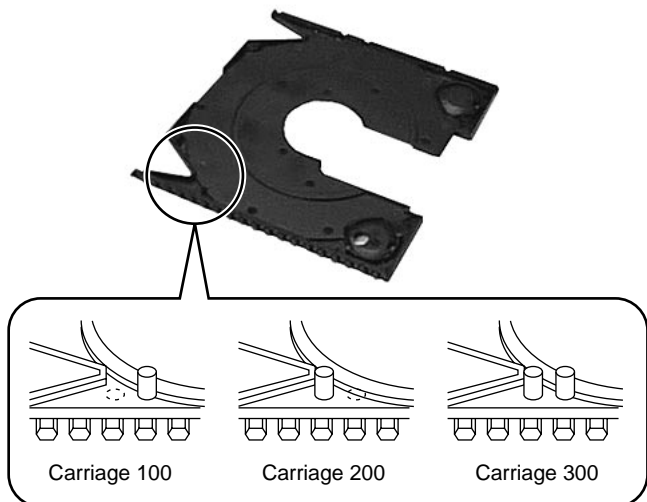

Method of distinguishing the back of Carriage.

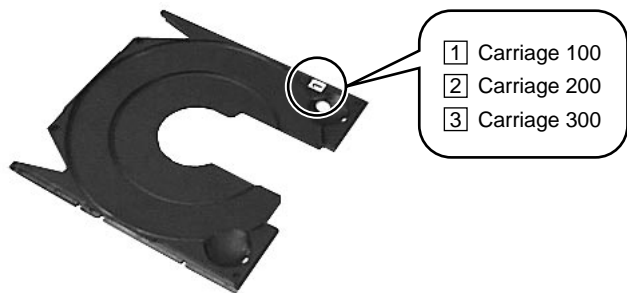

Method of distinguishing surface of Carriage.

2. Please do not disassemble Assy Holder L, R and the inside of and Drawer, and do not disassemble Assy Gear Drive which connects Assy Holder L with R. (The position match of each gear is necessary)
3. Please do not lose the gear (Bevel Gear 4 and Gear Idler A) not fixed while put in the axis.

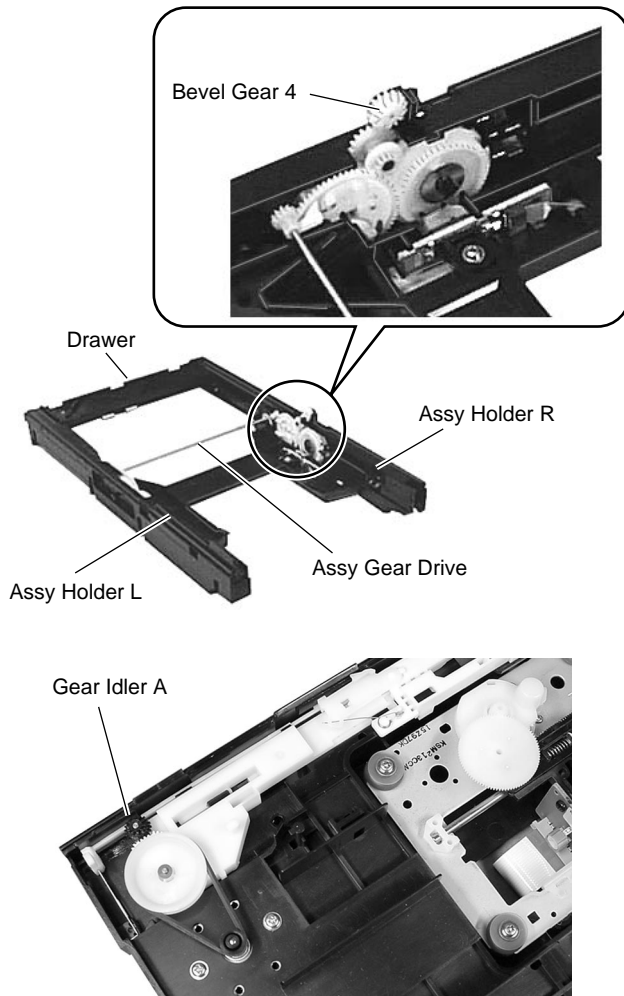

4. Carriage 300 is put in the Chassis side, and please put in the Drawer side without fail in order of Carriage 100 and 200.

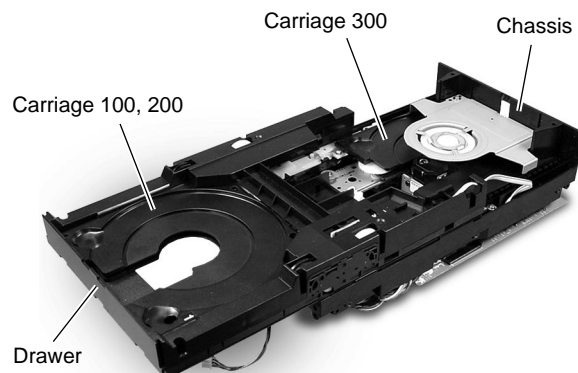



■ Drawer

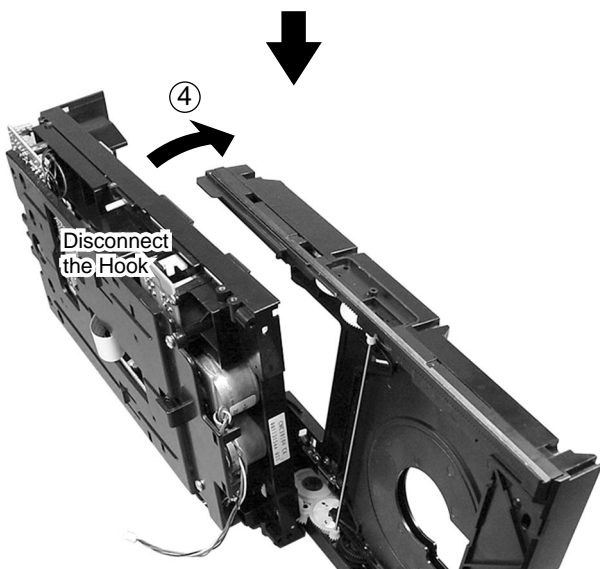
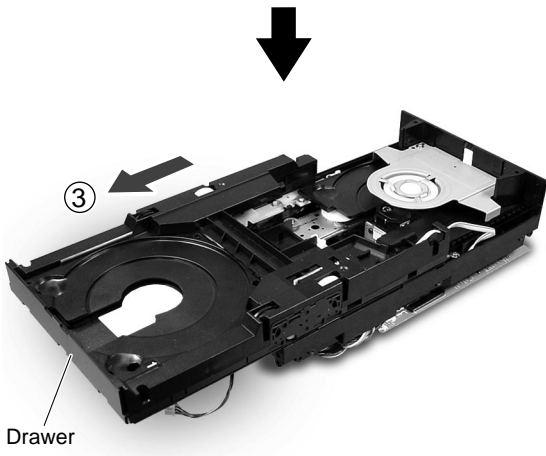
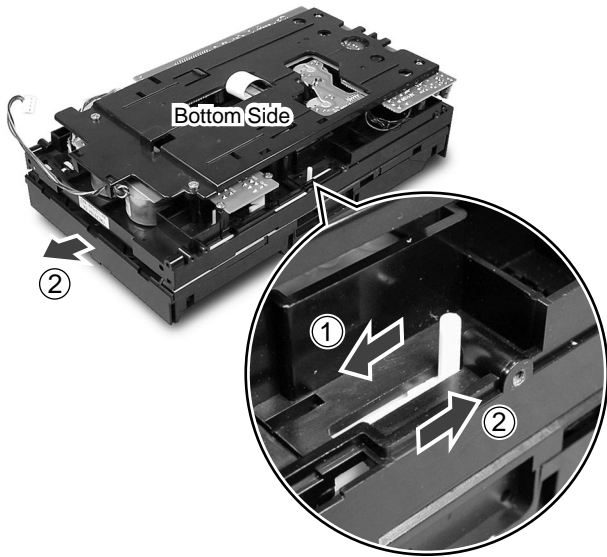

■ Disassembly of Ass'y Motor CRG S and Ass'y Motor DRW S

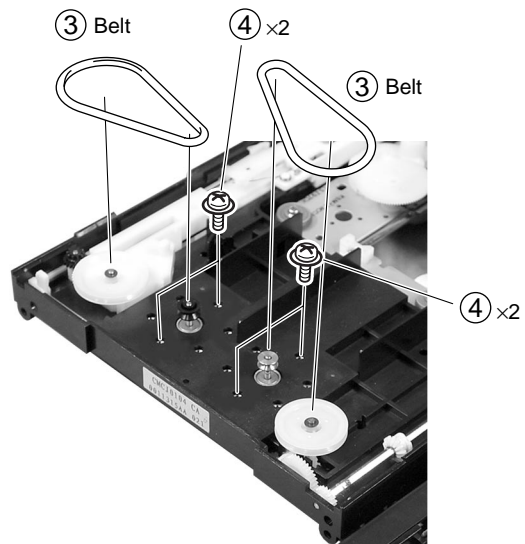
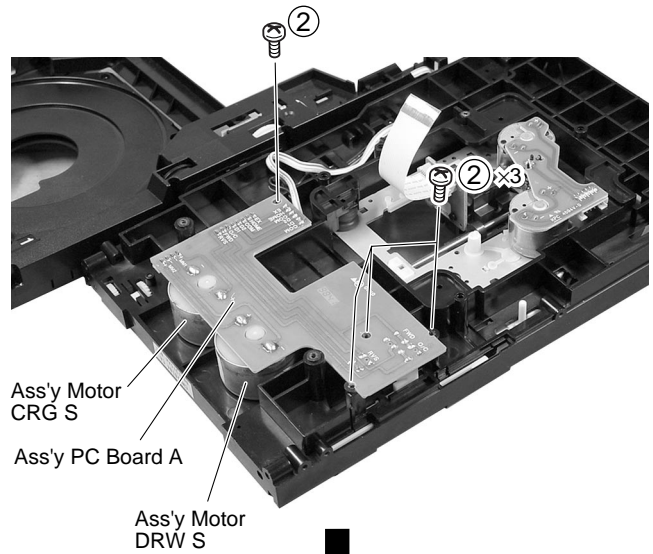
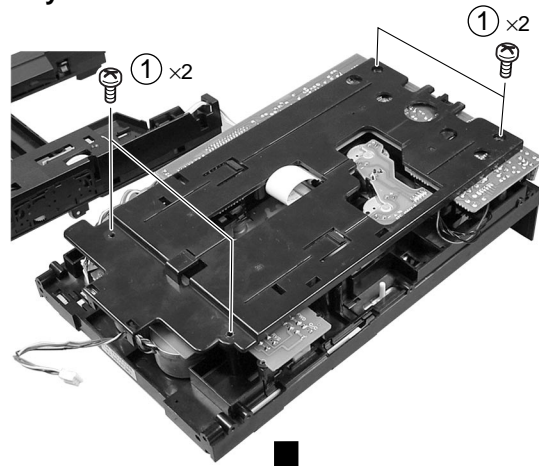

■ Chassis

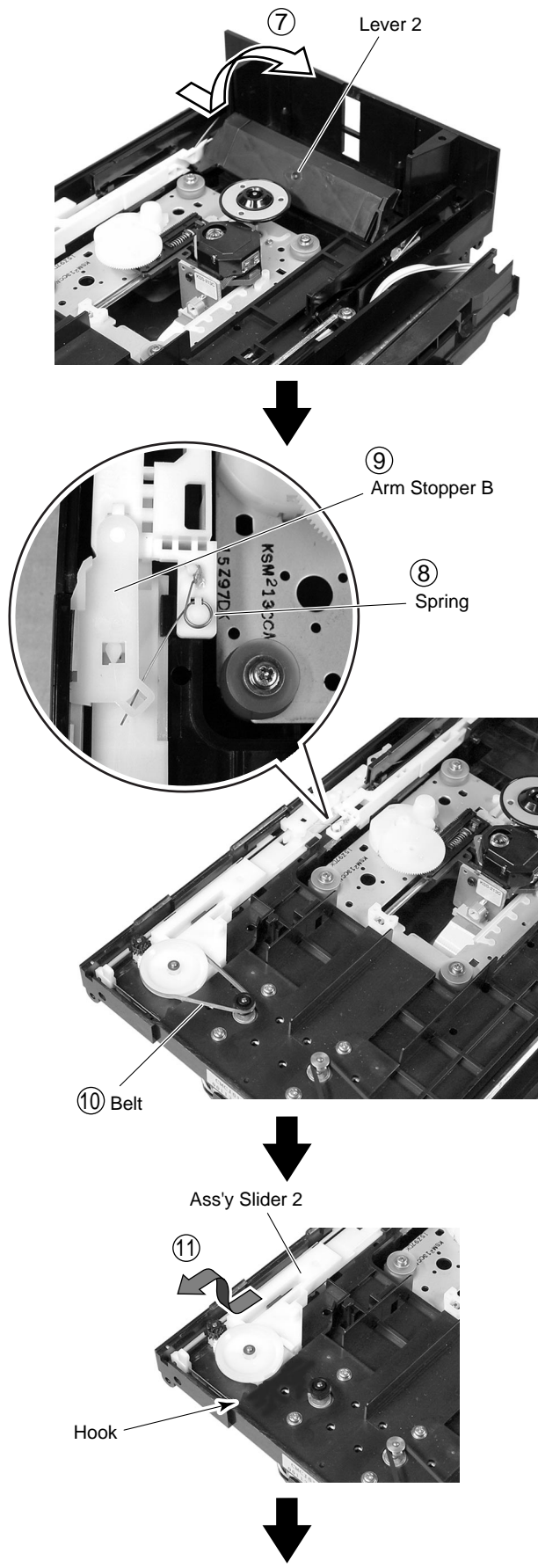
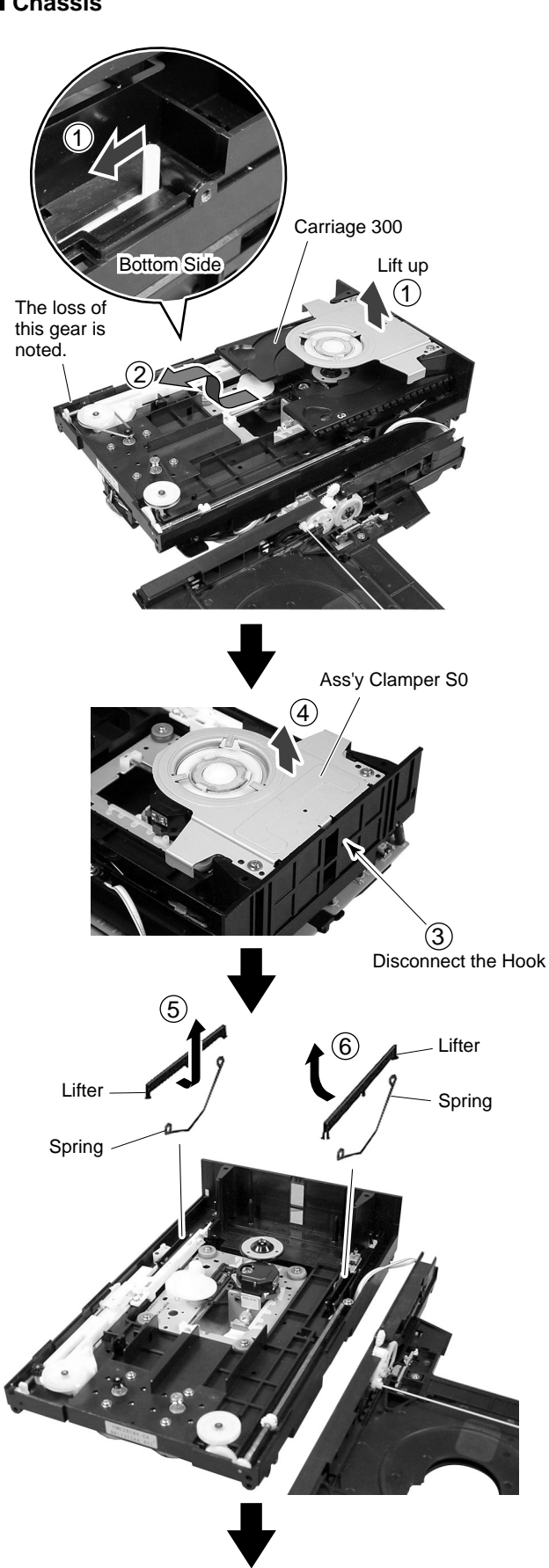

■ Disassembly of Carriage 100, 200

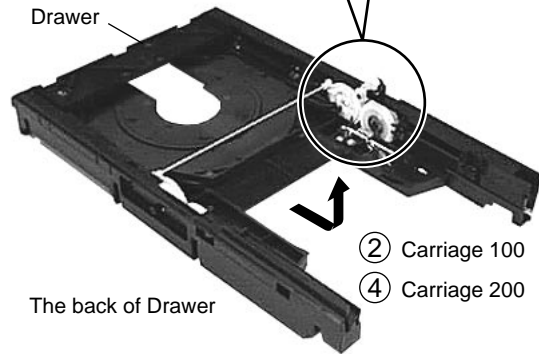
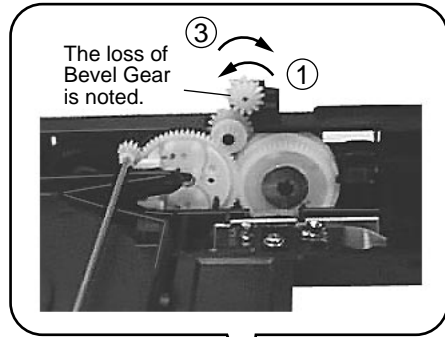
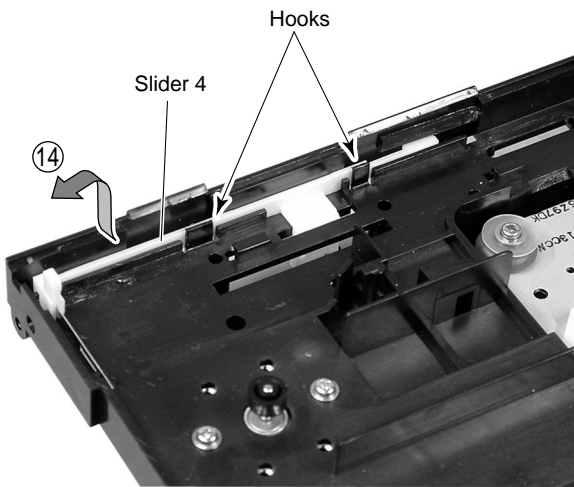
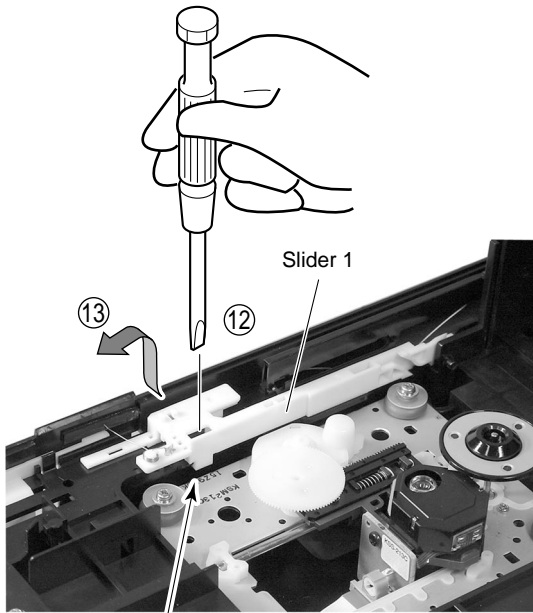

■ Assembly of Carriage 100, 200

(Carriage 100 is No.1 carriage. Carriage 200 is No.2 carriage.)

① After Bevel Gear is turned counterclockwise, and five rotations are made after lower side Pinion begins to turn, stops in the place where its rotation stopped.

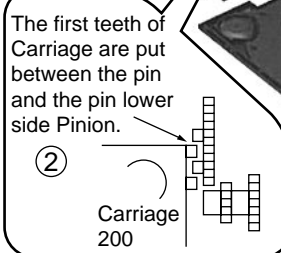
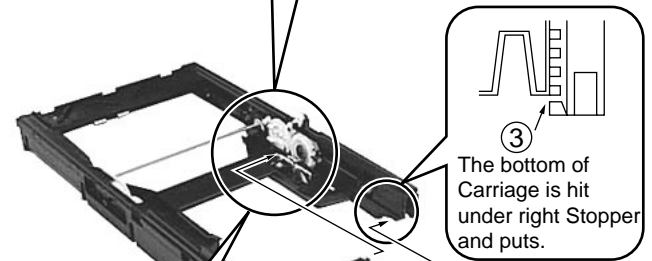
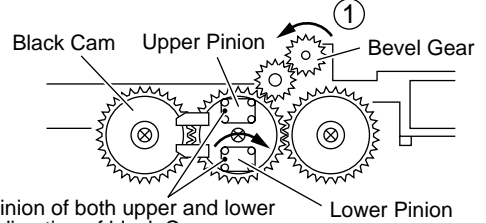



- Notes of procedure ③.

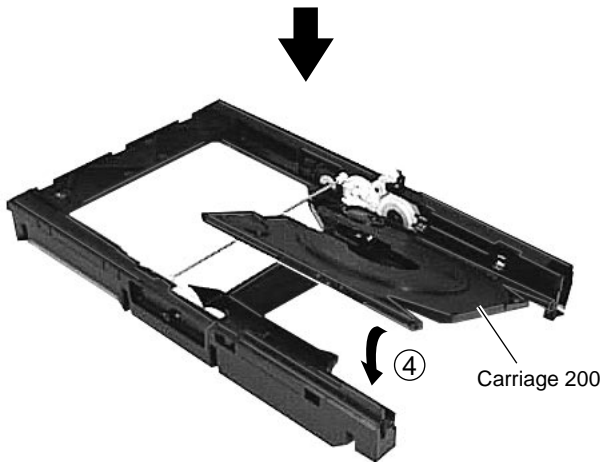
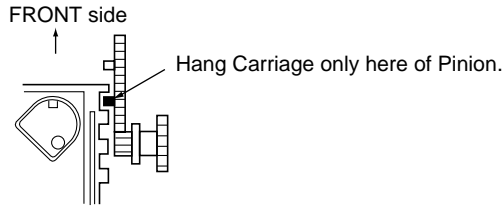

- ④-1 The other side of the side applied by ③ of Carriage is lightly pushed.
- ④-2 Puts Carriage 100 on Carriage 200 which applies by ④-1. Be careful about notes by ③ at this time.

- ⑤ Bevel Gear is turned clockwise. (direction of a rear side from a front side)

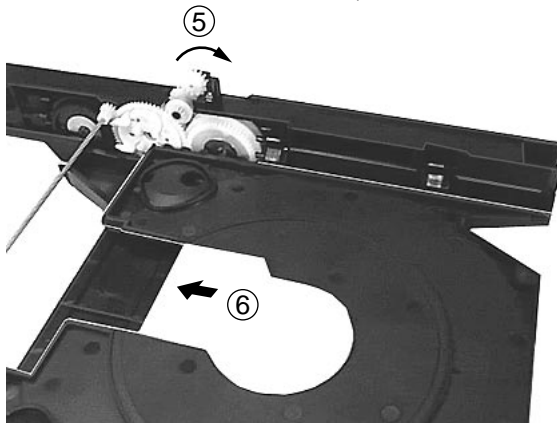

- ⑥-1 Carriage 200 moves to a front side.
- ⑥-2 Bevel Gear is turned as it is clockwise. (direction of a rear side from a front side)
- ⑥-3 Carriage 100 drops below.

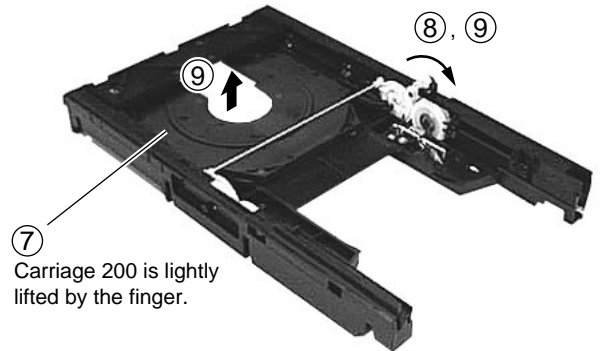

- ⑦ When Carriage 100 drops below, Carriage 200 is lightly lifted by the finger.  
Note : Lift it horizontally when you lift Carriage. Carriage inclines when it is not the horizontal, and mechanism locks.
- ⑧ Bevel Gear is turned clockwise (direction of a rear side from a front side) like the state of ⑦.
- ⑨ Carriage 200 lifts up. And, when the movement is started Carriage 100 to the direction of a front side, separates the hand which lifted Carriage 200.

- ⑩ Keeps turning Bevel Gear clockwise (direction of a rear side from a front side) until Carriage 100 bumps to the wall on a front side.

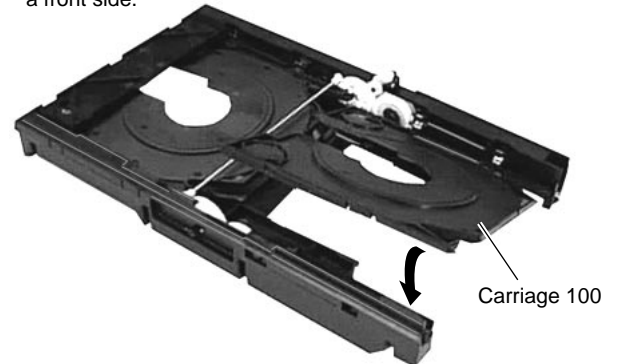

- ⑪ The position of a right and left, black cam is matched while confirming it from the table side of Drawer.

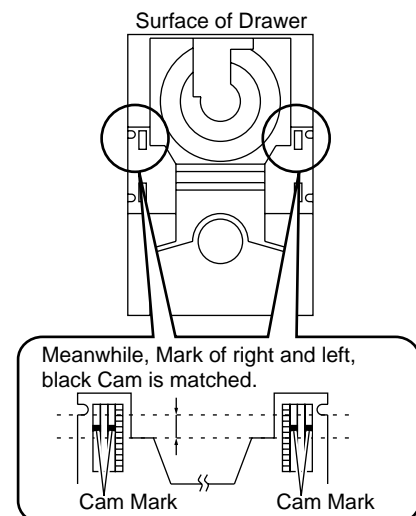

## ■ Assembly of Drawer and Chassis

The following work is done before Drawer is put on Chassis.

- (1) It is confirmed that Carriage 300 is clamped, and Clamper has fallen.
- (2) It is confirmed to Drawer to be built in neatly in order of Carriage 200 and 100.
- (3) Arm Stopper B is moved horizontally (inside) as shown in the figure below. (A)
- (4) Pulls Slider 2 until the lock comes off to the direction of ta front side. (B)

Note : Do not lift Arm Stopper B for above when you move Arm Stopper B.

There is a possibility to bend the spring when Arm Stopper B is lifted, and the spring bends. And, when Arm Stopper B becomes floatage feeling, Drawer is caught.

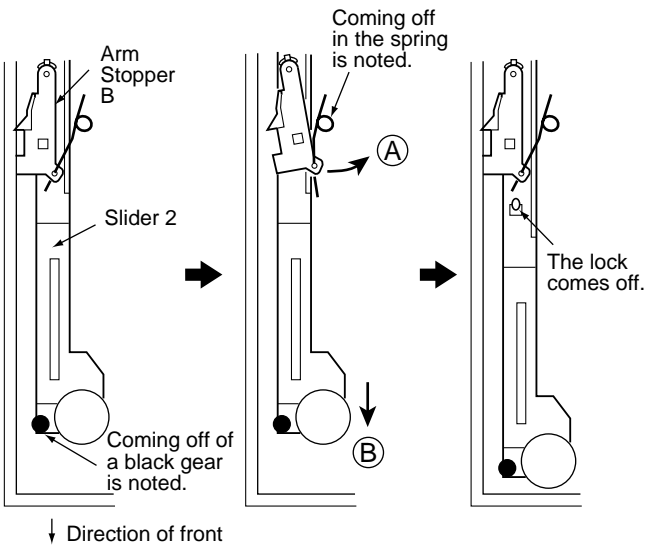

- (1) This ○ part of Drawer is put on Chassis like the arrow.

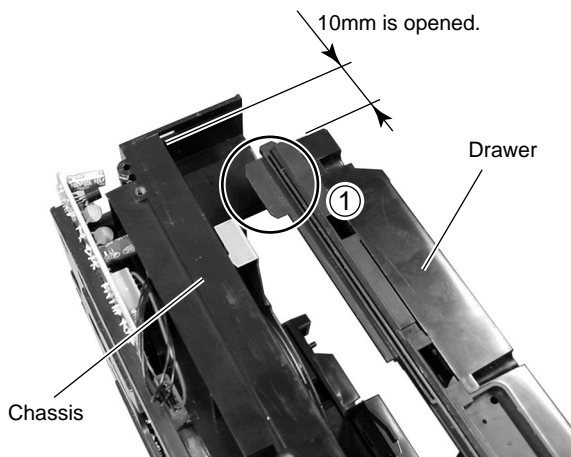

- (2) The lac teeth and Gear Idler A are matched, and it is pressed under the diagonal lightly.
- (3) Right this side of Drawer is lifted.
- (4) Drawer is moved back and forth, and stops Drawer with the point which it enters left.

- (5) Its right side is slowly lowered up to the angle by which Bevel Gear can do in the slide while doing Drawer back and forth by about 5mm.

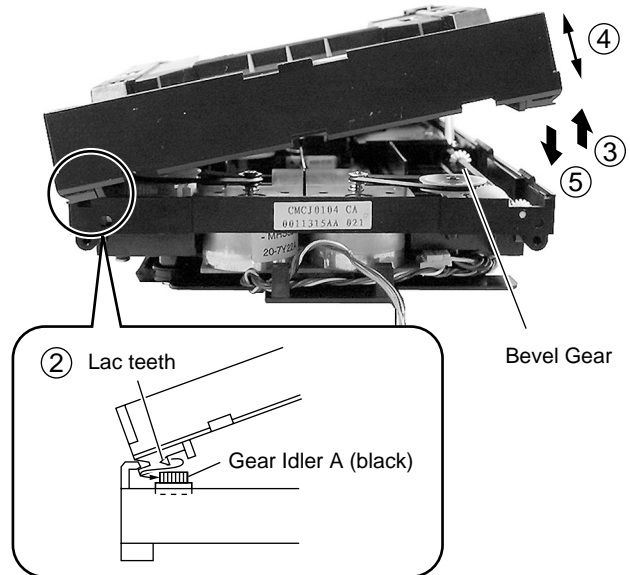

- (6) When peeps from the inside of Drawer when the receiving part of Gear is fixed into the concave part of Bevel Gear, the place where it is fixed is comprehensible.

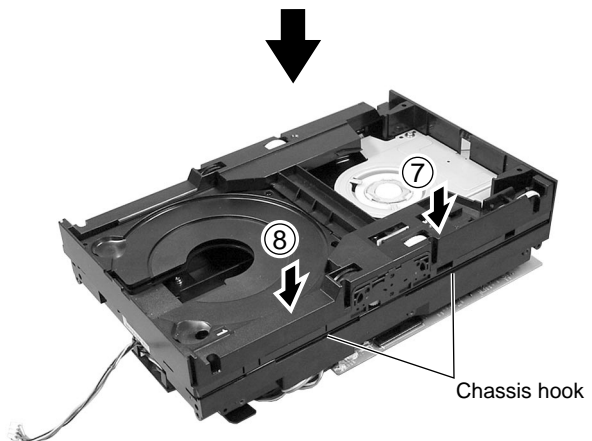
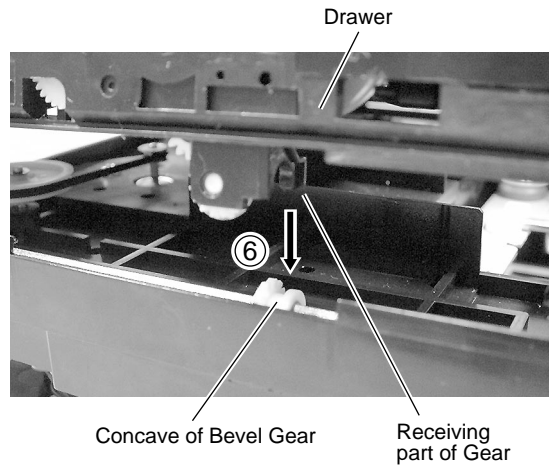



## 7.2 PARTS

### 7.2.1 IC

• The information shown in the list is basic information and may not correspond exactly to that shown in the schematic diagrams.

#### ■ LC876564 (DISPLAY/CTL ASSY : IC401)

##### • System Control IC

##### • Pin Function

NO.	Pin Name	I/O	Function
1	FCNJOG0	I	Function Jogger Input
2	FCNJOG1	I	Function Jogger Input
3	DTS-TDATA	I/O	Tuner communication DATA pin
4	DTS-PLLPERIOD	O	Tuner communication PERIOD pin
5	DTS-PLLCLOCK	O	Tuner communication CLOCK pin
6	VOLJOG0	I	Volume Jogger Input
7	VOLJOG1	I	Volume Jogger Input
8	VOL-CLOCK	O	Volume IC communication CLOCK pin
9	VOL-DATA	O	Volume IC communication DATA pin
10	(NC)	–	Not used
11	RESET	I	MCU low reset pin
12	XT1 (LOW CLK)	–	Sub-Clock 32.768KHz (Input)
13	XT2 (LOW CLK)	–	Sub-Clock 32.768KHz (Output)
14	VSS1	–	Ground
15	CF1 (MAIN CLK)	–	Main clock 8MHz (Input)
16	CF2 (MAIN CLK)	–	Main clock 8MHz (Output)
17	VDD1	–	5V power supply
18	KEY0	I	Keyboard Input (Analog)
19	KEY1	I	Keyboard Input (Analog)
20	KEY2	I	Keyboard Input (Analog)
21	DTS-COUNTRY	I	Tuner Country setting option pin
22	DTS-STRENGTH	I	Tuner Signal Strength
23	CHANNEL0	O	Control Audio Channel Output
24	CHANNEL1	O	Control Audio Channel Output
25	VOL-LATCH	O	Volume IC communication LATCH pin
26	SYS-STOP	I	No Power detection pin
27	(NC)	–	Not used
28	SYS-POWER	O	Control the audio power supply
29	REMOTE	I	Infra-red remote receiver input pin
30	VFD (GD1)	O	Output for VFD display controller digit
31	VFD (GD2)	O	Output for VFD display controller digit
32	VFD (GD3)	O	Output for VFD display controller digit
33	VFD (GD4)	O	Output for VFD display controller digit
34	VFD (GD5)	O	Output for VFD display controller digit
35	VFD (GD6)	O	Output for VFD display controller digit
36	VFD (GD7)	O	Output for VFD display controller digit
37	VFD (G08)	O	Output for VFD display controller digit
38	VFD (G09)	O	Output for VFD display controller digit
39	VFD (S18)	O	Output for VFD display controller segment
40	VFD (S17)	O	Output for VFD display controller segment
41	VFD (S16)	O	Output for VFD display controller segment
42	VFD (S15)	O	Output for VFD display controller segment
43	VFD (S14)	O	Output for VFD display controller segment
44	VFD (S13)	O	Output for VFD display controller segment
45	VFD (S12)	O	Output for VFD display controller segment
46	VDD3	–	Power Supply (+5V)
47	VFD (S11)	O	Output for VFD display controller segment

# XC-LA21

NO.	Pin Name	I/O	Function
48	VFD (S10)	O	Output for VFD display controller segment
49	VFD (S09)	O	Output for VFD display controller segment
50	VFD (S08)	O	Output for VFD display controller segment
51	VP	-	VFD Power Supply (-24V)
52	VFD (S07)	O	Output for VFD display controller segment
53	VFD (S06)	O	Output for VFD display controller segment
54	VFD (S05)	O	Output for VFD display controller segment
55	VFD (S04)	O	Output for VFD display controller segment
56	VFD (S03)	O	Output for VFD display controller segment
57	VFD (S02)	O	Output for VFD display controller segment
58	VFD (S01)	O	Output for VFD display controller segment
59	(NC)	-	Not used
60	(NC)	-	Not used
61	(NC)	-	Not used
62	(NC)	-	Not used
63	(NC)	-	Not used
64	DTS-PLLSTEREO	I	Tuner in stereo pin
65	RVS-SW	I	Changer - Slider Reverse position switch
66	FWD-SW	I	Changer - Slider Forward position switch
67	OP/CL-SW	I	Changer - Drawer open/close detect switch
68	CN1-SW	I	Changer - Carriage number 1 switch
69	CN2-SW	I	Changer - Carriage number 2 switch
70	HOME-SW	I	Changer - Carriage Home Position switch
71	EXTRA-SW	I	Changer - Carriage Extra Position switch
72	VDD4	-	Power Supply (+5V)
73	DMR	O	Drawer Motor Reverse control
74	DMF	O	Drawer Motor Forward control
75	CMR	O	Carriage Motor Reverse control
76	CMF	O	Carriage Motor Forward control
77	(NC)	-	Not used
78	(NC)	-	Not used
79	(NC)	-	Not used
80	CLK-POWER	O	Main Power Control
81	D1-LED	O	Top panel CD1 LED control
82	D2-LED	O	Top panel CD2 LED control
83	D3-LED	O	Top panel CD3 LED control
84	(NC)	-	Not used
85	CD-BUS0	I/O	CD Servo IC DATA BUS 0
86	CD-BUS1	I/O	CD Servo IC DATA BUS 1
87	CD-BUS2	I/O	CD Servo IC DATA BUS 2
88	CD-BUS3	I/O	CD Servo IC DATA BUS 3
89	VSS2	-	Ground
90	VDD2	-	Power Supply (+5V)
91	CD-CCE	O	CD Servo IC Chip-enable pin
92	CD-BUCK	O	CD Servo IC Bus Clock pin
93	CD-SW_PUIN	I	CD Servo Pickup Inner Switch
94	SYS-MUTE	O	System Muting
95	CD-POWER	O	CD Power Control pin
96	RDS-DATA	I	RDS IC communication DATA pin
97	RDS-CLOCK	I	RDS IC communication CLOCK pin
98	FLASH-OUTPUT	-	For Download program to FLASH type MCU
99	FLASH-INPUT	-	For Download program to FLASH type MCU
100	FLASH-CLK	-	For Download program to FLASH type MCU

### 7.2.2 DISPLAY

#### ■ 115-000920-000A (HNA-09SS20) (DISPLAY CONTROL ASSY : LCD401)

• FL DISPLAY

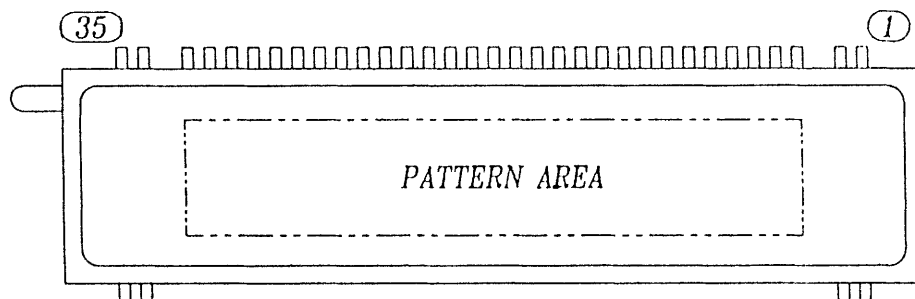

● Anode Connection

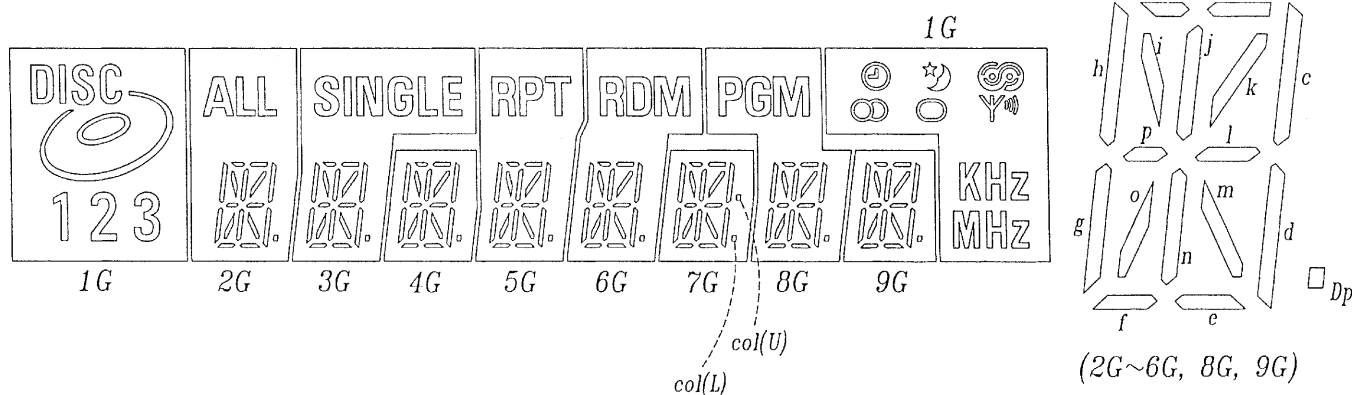

	1G	2G	3G	4G	5G	6G	7G	8G	9G
P1	DISC	a	a	a	a	a	a	a	a
P2	⊙	b	b	b	b	b	b	b	b
P3	1	c	c	c	c	c	c	c	c
P4	2	d	d	d	d	d	d	d	d
P5	3	e	e	e	e	e	e	e	e
P6	⊙	f	f	f	f	f	f	f	f
P7	☆	g	g	g	g	g	g	g	g
P8	⊙	h	h	h	h	h	h	h	h
P9	⊙	i	i	i	i	i	i	i	i
P10	⊙	j	j	j	j	j	j	j	j
P11	Y	k	k	k	k	k	k	k	k
P12	kHz	l	l	l	l	l	l	l	l
P13	MHz	m	m	m	m	m	m	m	m
P14	—	n	n	n	n	n	n	n	n
P15	—	o	o	o	o	o	o	o	o
P16	—	p	p	p	p	p	p	p	p
P17	—	Dp	Dp	Dp	Dp	Dp	col(U)	Dp	Dp
P18	—	ALL	SINGLE	—	RPT	RDM	col(L)	PGM	—

● Pin Connection

PIN NO.	35	34	33	32	31	30	29	28	27	26	25	24	23	22	21	20	19	18	17	16	15	14	13	12	11	10	9	8	7	6	5	4	3	2	1
CONNECTION	F2	F2	NP	1G	2G	3G	4G	5G	6G	7G	8G	9G	NC	NC	P18	P17	P16	P15	P14	P13	P12	P11	P10	P9	P8	P7	P6	P5	P4	P3	P2	P1	NP	F1	F1

\*\*\* NOTE \*\*\*  
 1) F<sub>n</sub> : Filament Pin  
 2) NP : No Pin  
 3) NC : No Connection Pin  
 4) nG : Grid Pin  
 5) P<sub>n</sub> : Anode Pin

### 7.3 REMOTE CONTROL UNIT

#### 7.3.1 SCHEMATIC DIAGRAM

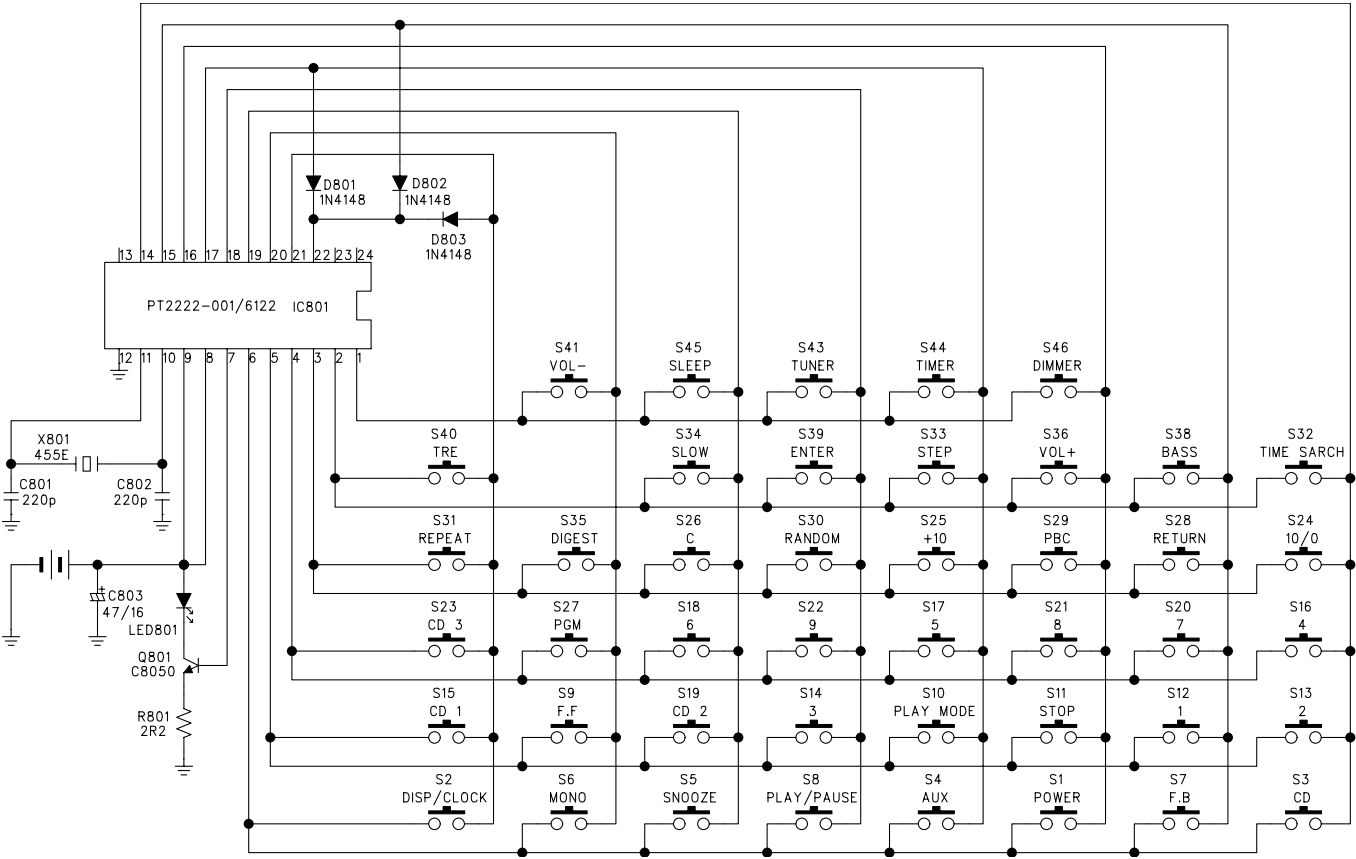

7.3.2 PCB DIAGRAM

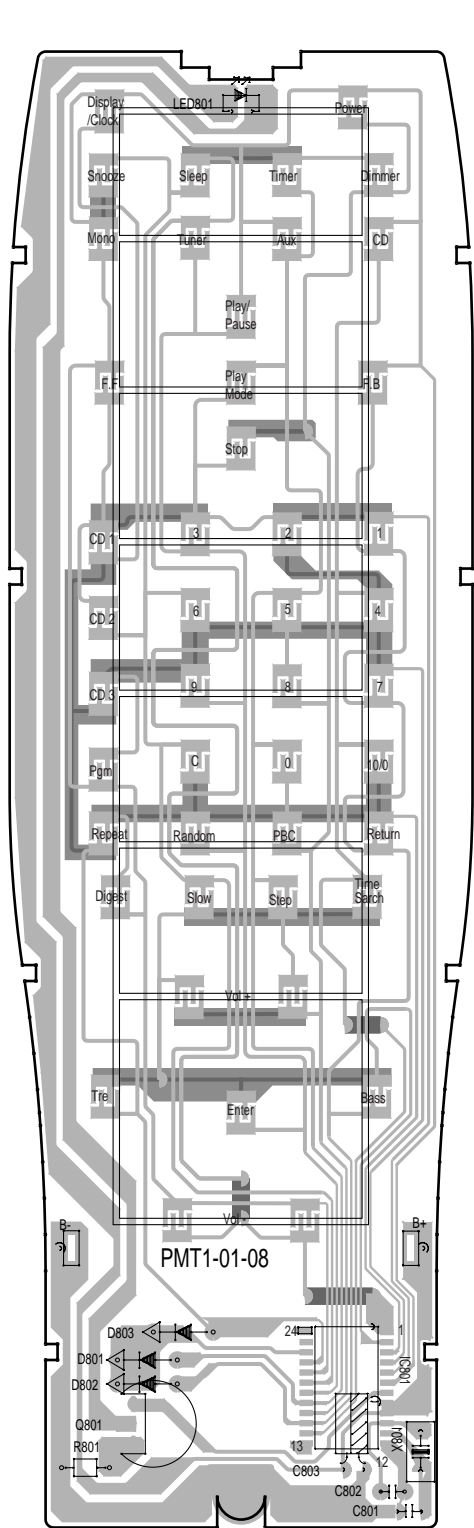

SIDE B

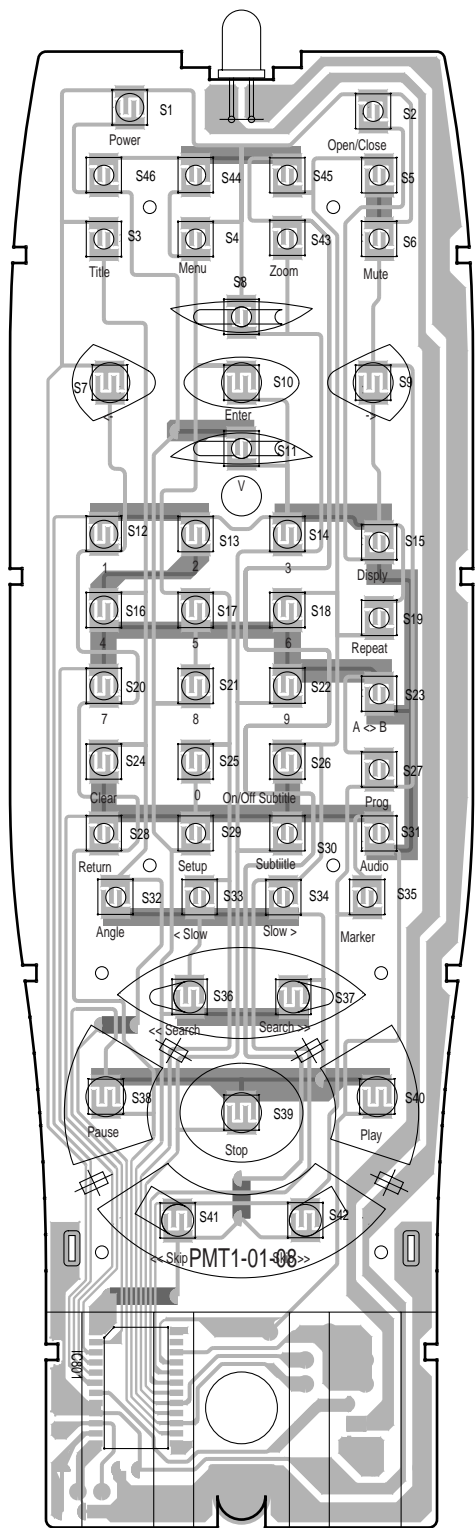

SIDE A

A  
B  
C  
D

## 8. PANEL FACILITIES AND SPECIFICATIONS

### 8.1 PANEL FACILITIES

#### ■ Front Panel

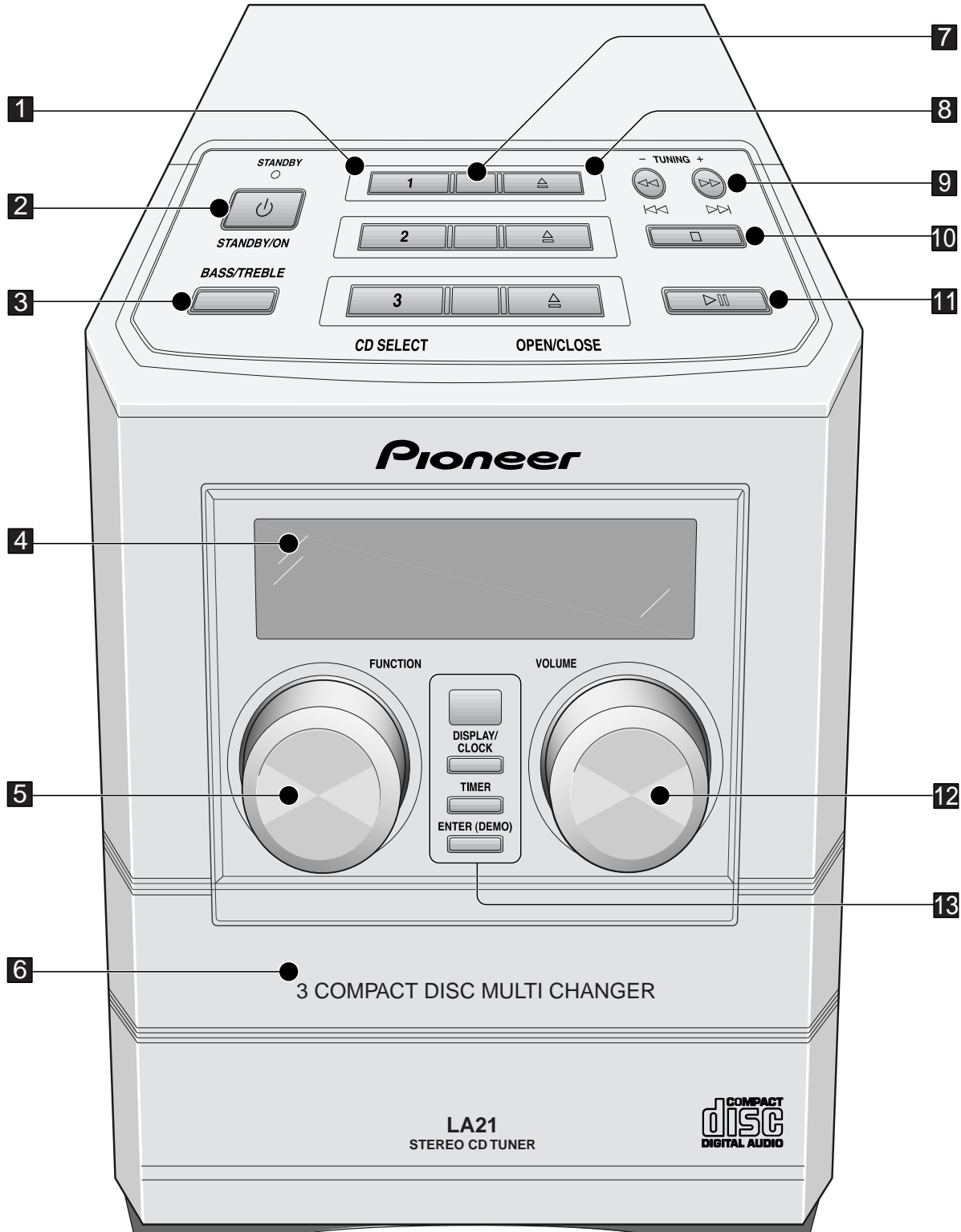

- 1 **CD SELECT 1 / 2 / 3** – Use to select CDs, and start playback if there's a disc loaded. Also switches the system on if it was in standby.
- 2 **⏻ STANDBY / ON** – Press to switch on or into standby.
- 3 **BASS / TREBLE** – Use to adjust the tone of the sound.
- 4 **Fluorescent display**
- 5 **FUNCTION** – Turn to select the source to listen to: CD, radio or an external component.
- 6 **Disc tray**
- 7 **Disc indicators** – Indicate whether a disc is loaded in that disc tray (blinks while loading; lights when loaded)
- 8 **OPEN / CLOSE ▲** – Use to open or close individual disc trays. Also switches the system on if it was in standby.
- 9 **◀◀ / |◀◀ / TUNING –** – When using the CD player, use to scan backwards, or skip back tracks. When using the radio, use for tuning and to select preset stations.
- ▶▶ / ▶▶▶ / **TUNING +** – When using the CD player, use to scan forwards, or skip forward tracks. When using the radio, use for tuning and to select preset stations.
- 10 **■** – Press to stop a CD playing. Also cancels auto scan tuning.
- 11 **▶||** – Press to start or restart a CD playing, or pause a disc that's already playing. Also switches the system on if it was in standby.
- 12 **VOLUME** – Turn to adjust the volume.
- 13 **DISPLAY / CLOCK** – Press to change the CD or station information shown in the display. Also use to set/display the clock.

**TIMER** – Use to set the wake up.

**ENTER (DEMO)** – Use to save a radio station preset; set the clock or timer. Also switches the demo on/off.

■ Display

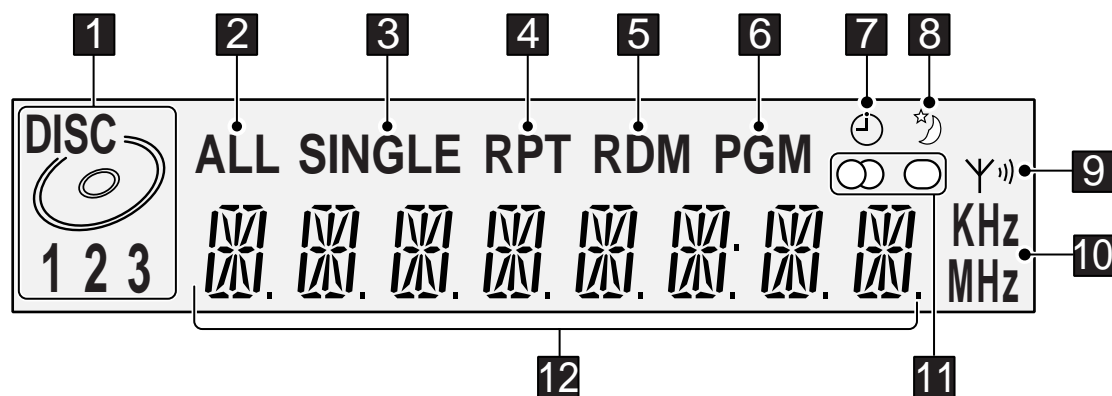

- 1 **Current disc indicator** – Shows the current disc (blinks when paused).
- 2 **ALL** – Lights in All disc play mode (all CDs loaded will play).
- 3 **SINGLE** – Lights in Single disc play mode (only the currently selected disc will play).
- 4 **RPT** – Lights in repeat play mode.
- 5 **RDM** – Lights in random play mode.
- 6 **PGM** – Lights when the track order has been programmed.
- 7 **⌚** – Lights when the wake up timer has been set.
- 8 **🌙** – Lights when the sleep timer has been set.
- 9 **Ψ** – indicates the strength of the broadcast signal.
- 10 **kHz / MHz** – Indicates an FM frequency (MHz) or an AM frequency (kHz).
- 11 **⊖ ⊕** – Indicates whether you're listening to the radio in stereo or mono.
- 12 **Character display**

Remote Control Unit

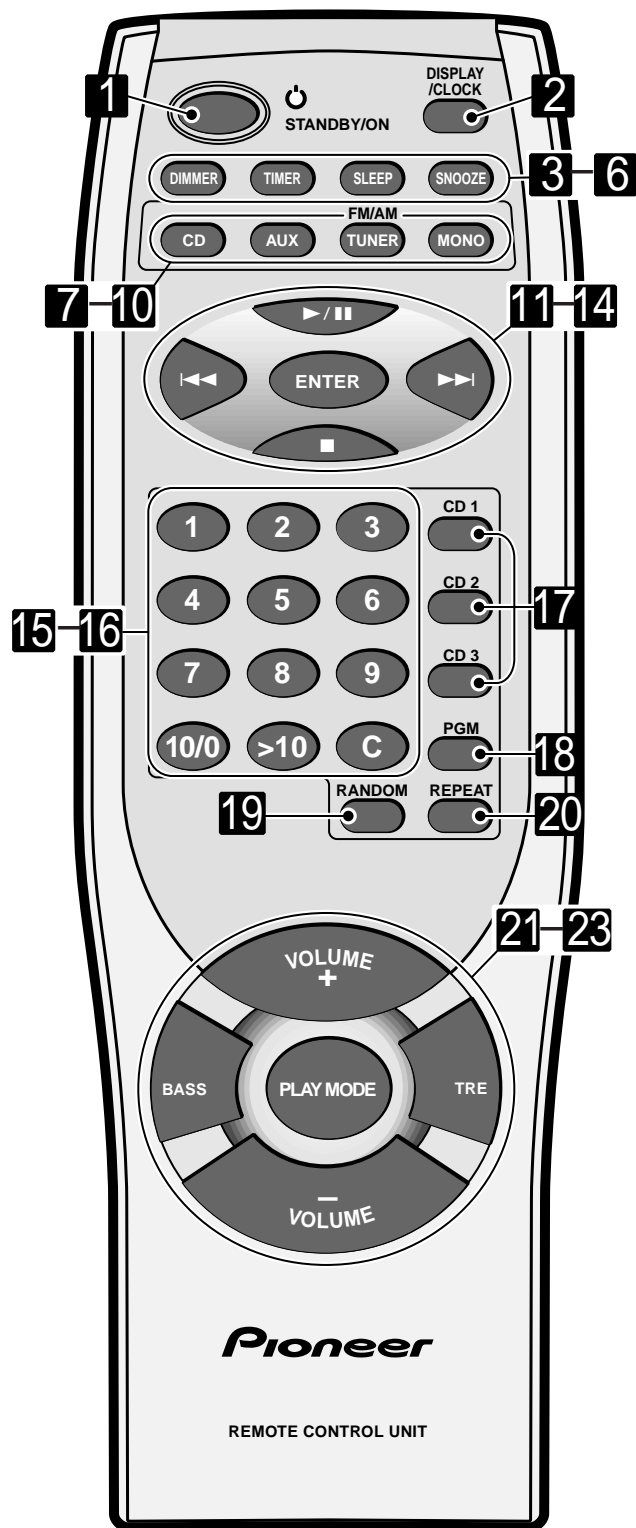

- 1 **STANDBY/ON** – Press to switch the unit on or into standby.
- 2 **DISPLAY/CLOCK** – Press to change the information shown in the display.
- 3 **DIMMER** – Use to change the brightness of the display.
- 4 **TIMER** – Press to set the wake up timer.
- 5 **SLEEP** – Press to set the sleep timer.
- 6 **SNOOZE** – Press for snooze function when using the wake up timer.
- 7 **CD** – Press for CD mode. Also switches the system on if it was in standby.
- 8 **AUX** – Press for auxiliary mode. Also switches the system on if it was in standby.
- 9 **FM/AM TUNER** – Press for tuner mode, and to switch between AM and FM. Also switches the system on if it was in standby.
- 10 **MONO** – Press to hear a stereo FM broadcast in mono (improves the sound quality).
- 11 **▶/||** – Press to start or restart playback, or pause a disc that's already playing.
- 12 **◀◀ and ▶▶** – When listening to CDs, press to skip back/forward tracks; press and hold for fast reverse/forward play. When listening to the radio, use for turning and use to tune into stations and select preset stations.
- 13 **ENTER** – Use to save a radio station preset; set the clock or timer.
- 14 **■** – Press to stop playback. Also cancels auto scan tuning.
- 15 **Number buttons** – When playing CDs, use to select track numbers. When listening to the radio, use to select preset stations.
- 16 **C** – Press to clear a CD playlist.
- 17 **CD buttons** – Press to select discs. Also switches the system on if it was in standby.
- 18 **PGM** – Press to start programming a CD playlist.
- 19 **RANDOM** – Press to start random CD playback.
- 20 **REPEAT** – Use to select the repeat mode (1-track, current disc or all-disc).
- 21 **VOLUME +/-** – Use to adjust the volume.
- 22 **BASS / TRE** – Use to adjust the tone (bass and treble) of the sound.
- 23 **PLAY MODE** – Use to select single disc play, or all-disc play.



## 8.2 SPECIFICATIONS

### Amplifier Section (M-LA21)

Continuous Power (RMS) .....	100 W + 100 W (1 kHz, THD 10%, 8Ω)
Peak Music Power Output .....	2500 W

### FM Tuner Section

Frequency Range .....	87.5 – 108 MHz
Antenna .....	75 Ω, unbalanced

### AM Tuner Section

Frequency Range .....	531 kHz – 1,602 kHz (9 kHz step)
.....	530 kHz – 1,700 kHz (10 kHz step)
Antenna .....	Loop antenna

### Compact Disc Player Section

Type .....	Compact disc digital audio system
Usable discs .....	Compact discs
Channels .....	2 (stereo)
Frequency Response .....	20 Hz–20 kHz
Wow and Flutter .....	Limit of measurement (0.001%) or less (EIAJ)

### Power Section & Miscellaneous

Power Requirements .....	AC 110-127/220-230/240 V (switchable), 50/60 Hz
Power Consumption (ON mode) (Total including M-LA21) .....	538 W
Power Consumption (Standby mode) .....	1 W
Dimensions	
Stereo CD tuner .....	160(W) x 176(H) x 323.5(D) mm
Stereo power amplifier .....	160(W) x 176(H) x 315(D) mm
Weight	
Stereo CD tuner .....	4.0 kg
Stereo power amplifier .....	5.1 kg

### Accessories

• Operating instructions .....	1
• Remote control unit .....	1
• FM wire antenna .....	1
• AM loop antenna .....	1
• AAA' size R03 batteries .....	2
• RCA audio cable .....	1
• Power-cord plug conversion adaptor (Except Argentinian model) .....	2

### Speaker System:

Enclosure .....	Bass-reflex bookshelf type
System .....	16 cm 3-way system
Loudspeakers	
Woofers .....	16 cm cone type
Mid-range .....	5.2 cm cone type
Tweeter .....	2.4 cm ceramic dome type
Nominal impedance .....	8 Ω
Frequency response .....	40 Hz–20,000 Hz
Maximum input .....	100 W
External dimensions ..	220(W) x 340(H) x 270(D) mm
Weight .....	3.8 kg

**NOTE:** Specifications and design subject to possible modification without notice, due to improvements.