

Circuitry for Inexpensive Relative Humidity Measurement

National Semiconductor
Application Note 256
August 1981



Of all common environmental parameters, humidity is perhaps the least understood and most difficult to measure. The most common electronic humidity detection methods, albeit highly accurate, are not obvious and tend to be expensive and complex (See Box). Accurate humidity measurement is vital to a number of diverse areas, including food processing, paper and lumber production, pollution monitoring and chemical manufacturing. Despite these and other applications, little design oriented material has appeared on circuitry to measure humidity. This is primarily due to the small number of transducers available and a generally accepted notion that they are difficult and expensive to signal condition.

Although not as accurate as other methods, the sensor described by the response curve (Figure 1) is inexpensive and provides a direct readout of relative humidity. The curve reveals a close exponential relationship between the sensor and relative humidity spanning almost 4 decades of resistance. Linearization of this curve may be accomplished by taking the logarithm of the resistance value and utilizing breakpoint approximation techniques to minimize the residual non-linearities. A further consideration in signal conditioning is that the manufacturer specifies that no significant DC current component may pass through the sensor. This device must be excited with an unbiased AC waveform to preclude detrimental electrochemical migration. In addition, it has a 0.36 RH unit/ $^{\circ}$ C positive temperature coefficient. The sensor is a chemically treated styrene copolymer which has a surface layer whose resistivity varies with relative humidity. Because the humidity sensitive portion of the sensor is at its surface, time response is reasonably rapid and is on the order of seconds.

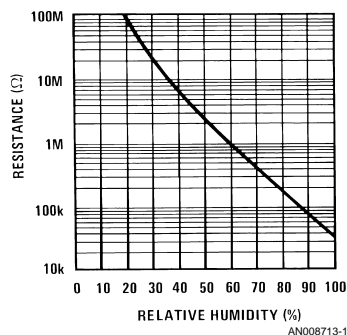

FIGURE 1. Phys-Chemical Research Corp. Model PCRC-55 Humidity Sensor

A block diagram of the concept chosen to instrument the sensor appears in Figure 2. An amplitude stabilized square wave which is symmetrical about zero volts is used to provide a precision alternating current through the sensor, satisfying the requirement for a zero DC component drive. The current through the sensor is fed into a current sensitive (e.g. the input is at virtual ground) logarithmic amplifier, which linearizes sensor response. The output of the logarithmic amplifier is scaled, rectified and filtered to provide a DC output which represents relative humidity. Residual non-linearity due to the sensor's non-logarithmic response below RH = 40% is compensated by breakpoint techniques in this final stage.

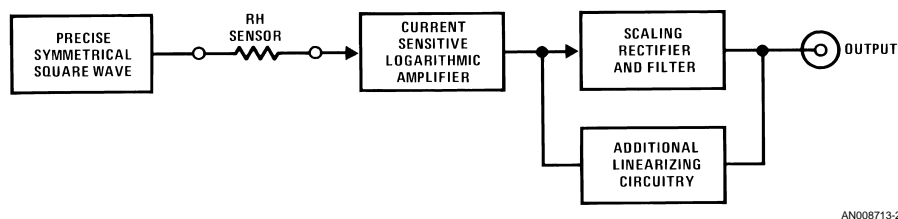

FIGURE 2.

The detailed circuitry appears in Figure 3. It is worth noting that the entire function described in Figure 2 requires a small number of inexpensive ICs. This is accomplished by novel circuitry approaches, especially in the design of the logarithmic amplifier. The stabilized symmetrical square wave is generated by A1, $\frac{1}{4}$ of an LF347 quad amplifier. A1 is set up in a positive feedback configuration, causing it to oscillate. The output of A1 is current limited and clamped to ground for either polarity output by the LM334 current source diode bridge combination. The LM334 is programmed by the 15 Ω resistor to current limit at about 5 mA. This forces the voltage across the 120 Ω –1.5 k Ω resistor string to stabilize at about ± 8 V. Each time A1's output changes state the charging cur-

rent into the 0.002 μ F capacitor reverses, causing the amplifier to switch again when the capacitor reaches a threshold established by the 120 Ω –1.5 k Ω divider (waveforms, Figure 4). This circuit's output is buffered by the A1 follower. The amplitude stability of the waveform is dependent upon the +0.33%/ $^{\circ}$ C temperature coefficient of the LM334. This T.C. has been intentionally designed into the LM334 so that it may be used in temperature sensing and compensation applications. Here, the negative 0.3%/ $^{\circ}$ C temperature dependence of the humidity sensor is reduced by more than an order of magnitude by the LM334's T.C. and thermally induced inaccuracy in the humidity sensor's response drops out as an error term. In practice, the LM334 should be mounted in

proximity to the humidity sensor. The residual $-0.03\%/^{\circ}\text{C}$ temperature coefficient is negligibly small compared to the sensors $\pm 1\%$ accuracy specification.

The output square wave is used to drive current through the sensor and into the summing junction of another $1/4$ of A1, which is connected as a logarithmic amplifier. On negative cycles of the input waveform the transistor (Q1) in the feedback loop provides logarithmic response, due to the well known relationship between V_{BE} and collector current in

transistors. During positive excursions of the input waveform the diode provides feedback to the amplifier's summing junction. In this manner the summing junction always remains at virtual ground while the input current is expressed in logarithmic form by the negative going square wave at the transistor emitter. Since the summing junction is always at ground potential the sensor sees the required symmetrical drive (waveforms, Figure 5).

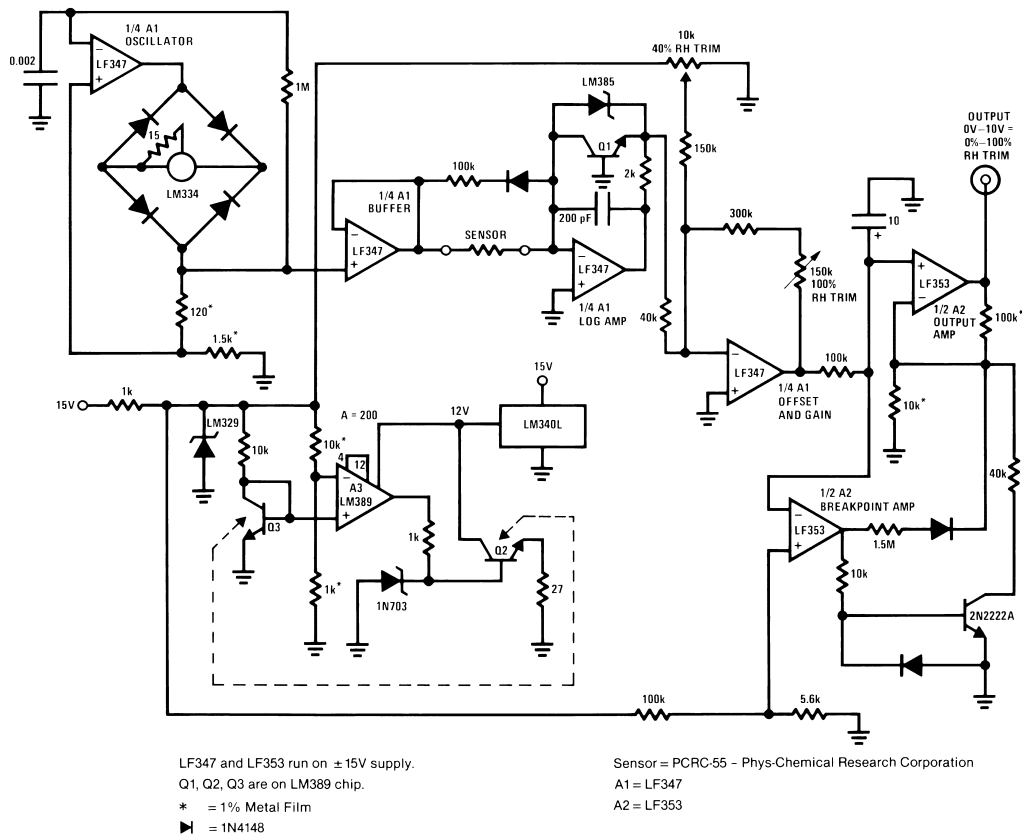

FIGURE 3.

The output of this stage is fed to another $1/4$ of A1. This amplifier is used to sum in the 40% RH trim and provide adjustable gain to set the 100% RH trim. The output is filtered to DC and routed to one half of A2, an LF353, which unloads the filter and provides additional gain and the final output.

The other $1/2$ of A2 is used to compensate the sensor departure from logarithmic conformity below 40% RH (Figure 1). This is accomplished by changing the gain of the output amplifier for RH readings below 40%. The input to the output amplifier is sensed by the breakpoint amplifier. When this input goes below RH = 40% (about 0.36V at the output amplifiers "+" terminal) the breakpoint amplifier swings positive. This turns on the 2N2222A, causing the required gain

change to occur at the output amplifier. For RH values above 40% the transistor is off and the circuits linearizing function is determined solely by the logarithmic amplifier.

In logarithmic configurations such as this, Q1's DC operating point will vary wildly with temperature and the circuit normally requires careful attention to temperature compensation, resulting in the expense associated with logarithmic amplifiers. Here, A3, an LM389 audio amplifier IC which also contains three discrete transistors, is used in an unorthodox configuration to eliminate all temperature compensation requirements. In addition, the cost of the log function is reduced by an order of magnitude compared to available ICs and modules. Q3 functions as a chip temperature sensor

while Q2 serves as a heater. The amplifier senses the temperature dependent V_{BE} of Q3 and drives Q2 to servo the chip temperature to the set-point established by the 10 k Ω -1 k Ω divider string. The LM329 reference ensures power supply independence of the temperature control. Q1 operates in this tightly controlled thermal environment (typically 50°C) and is immune to ambient temperature shifts. The LM340L 12V regulator ensures safe operation of the LM389, a 12V device. The zener at the base of Q2 prevents servo lock-up during circuit start-up. Because of the small size of the chip, warm-up is quick and power consumption low. Figure 6 shows the thermal servo's performance for a step function of 7°C change in set-point. The step is shown in trace A while the LM389 output appears in trace B. The output responds almost instantaneously and complete settling to the new set-point occurs within 100 ms.

To adjust this circuit, ground the base of Q2, apply circuit power and measure the collector potential of Q3, at known room temperature. Next, calculate what Q3's collector potential will be at 50°C, allowing -2.2 mV/°C. Select the 1k value to yield a voltage close to the calculated 50°C potential at the LM389's negative input. This can be a fairly loose trim, as the exact chip temperature is unimportant so long as it is stable. Finally, unground Q2's base and the circuit will servo. This may be functionally checked by reading Q3's collector voltage and noting stability within 100 μ V (0.05°C) while blowing on A3.

To calibrate the circuit for RH, place a 35 k Ω resistor in the sensor position and trim the 150 k Ω pot for an output of 10V. Next, substitute an 8 M Ω resistor for the sensor and trim the 10k potentiometer for an output of 4V. Repeat this procedure until the adjustments do not interfere with each other. Finally, substitute a 60 M Ω resistor for the sensor and select the nominal 40 k Ω value in the breakpoint amplifier for a reading of RH = 24%. It may be necessary to select the 1.5 M Ω value to minimize "hop" at the circuit output when the breakpoint is activated. The circuit is now calibrated and will read ambient relative humidity when the PCRC-55 sensor is connected.

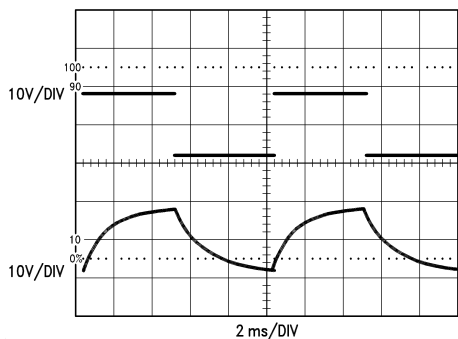

FIGURE 4.

AN008713-4

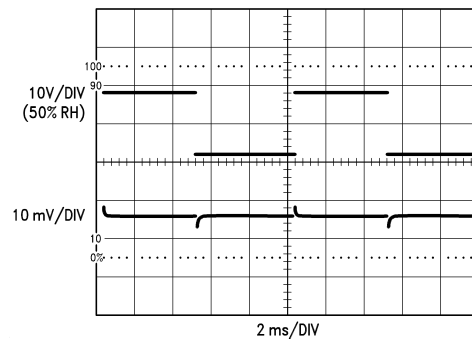

FIGURE 5.

AN008713-5

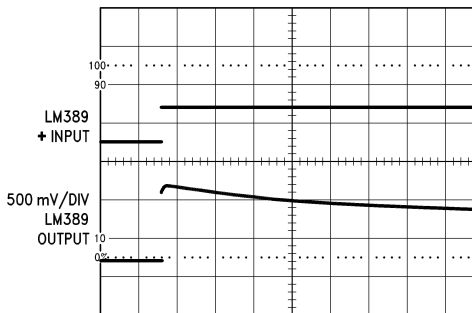

FIGURE 6.

AN008713-6

HUMIDITY

Humidity is simply water gas. In air the humidity may vary from zero percent for 90°F dry air to as much as 4.5 percent for heavily water laden air at 90°F. The amount of water air will hold is dependent upon temperature. *Relative* humidity is an expression denoting the ratio of water vapor in the air to the amount possible in saturated air at the same temperature.

Some of the more common ways of expressing humidity related information include wet bulb temperature, dew point and frost point. Wet bulb temperature refers to the minimum temperature reached by a wetted thermometer bulb in a stream of air. The dew point is the point at which water saturation occurs in air. It is evidenced by water condensation. When temperatures below 0°C are required to produce this phenomenon it is called the frost point.

Other measurements and ways of expressing humidity exist and are useful in a variety of applications. For additional information consult the bibliography.

BIBLIOGRAPHY

1. "Humidity Sensors"—brochure describing Models PCRC-11 and PCRC-55 Relative Humidity Sensors. Phys-Chemical Research Corp.; New York.
2. "Humidity Measurement"—*Instrumentation Technology*, reprint P. R. Wiederhold. Available from General Eastern Corp.; Watertown, Mass.
3. "Handbook of Transducers for Electronic Measuring Systems"—Norton, Harry N.; Prentice Hall, Inc.; 1969.
4. "Electric Hygrometers"—Wexler, A.; NBS Circular 586; NBS Washington, D.C. 1957.
5. "An elegant 6-IC circuit gauges relative humidity"—Williams, James M.; *EDN Magazine*, June 5, 1980.

Book
Extract
End

LIFE SUPPORT POLICY

NATIONAL'S PRODUCTS ARE NOT AUTHORIZED FOR USE AS CRITICAL COMPONENTS IN LIFE SUPPORT DEVICES OR SYSTEMS WITHOUT THE EXPRESS WRITTEN APPROVAL OF THE PRESIDENT OF NATIONAL SEMICONDUCTOR CORPORATION. As used herein:

1. Life support devices or systems are devices or systems which, (a) are intended for surgical implant into the body, or (b) support or sustain life, and whose failure to perform when properly used in accordance with instructions for use provided in the labeling, can be reasonably expected to result in a significant injury to the user.
2. A critical component in any component of a life support device or system whose failure to perform can be reasonably expected to cause the failure of the life support device or system, or to affect its safety or effectiveness.



National Semiconductor Corporation
Americas
Tel: 1-800-272-9959
Fax: 1-800-737-7018
Email: support@nsc.com

National Semiconductor Europe
Fax: +49 (0) 1 80-530 85 86
Email: europe.support@nsc.com
Deutsch Tel: +49 (0) 1 80-530 85 85
English Tel: +49 (0) 1 80-532 78 32
Français Tel: +49 (0) 1 80-532 93 58
Italiano Tel: +49 (0) 1 80-534 16 80

National Semiconductor Asia Pacific Customer Response Group
Tel: 65-2544466
Fax: 65-2504466
Email: sea.support@nsc.com

National Semiconductor Japan Ltd.
Tel: 81-3-5620-6175
Fax: 81-3-5620-6179

www.national.com

National does not assume any responsibility for use of any circuitry described, no circuit patent licenses are implied and National reserves the right at any time without notice to change said circuitry and specifications.