

Buck-based LED Drivers using the HV9910/HV9910B

by Rohit Tirumala, Senior Applications Engineer and Angel Gentchev, Products Development Manager

Fundamental Buck Converter topology is an excellent choice for LED drivers in off-line (as well as low-voltage) applications as it can produce a constant LED current at very high efficiencies and low cost. A peak-current-controlled buck converter can give reasonable LED current variation over a wide range of input and LED voltages and needs little effort in feedback control design. Coupled with the fact that these converters can be easily designed to operate at above 90% efficiency, the buck-based driver becomes an unbeatable solution to drive High Brightness LEDs.

The Supertex HV9910/HV9910B provides a low-cost, low component count solution to implement the continuous mode buck converter. HV9910/HV9910B has two current sense threshold voltages – an internally set 250mV and an external voltage at the LD pin. The actual threshold voltage will be the lower of the internal 250mV and the voltage at the LD pin.

The low sense voltage allows the use of low current sense resistor values. HV9910/HV9910B operates down to 8V input, which is required for automobile applications, and can take a maximum of 450V input, which makes it ideal for off-line applications. It also has an internal regulator that supplies power to the IC from the input voltage, eliminating the need for an external low voltage power supply. It is capable of driving the external FET directly, without the need for additional driver circuitry. Linear or PWM dimming can also be easily implemented using the HV9910/HV9910B.

This Application Note discusses the design of a buck-based LED driver using the HV9910/HV9910B with the help of an off-line application example. The same procedure can be used to design LED drivers with any other lower voltage AC or DC input; 12V for example.

Circuit Diagram

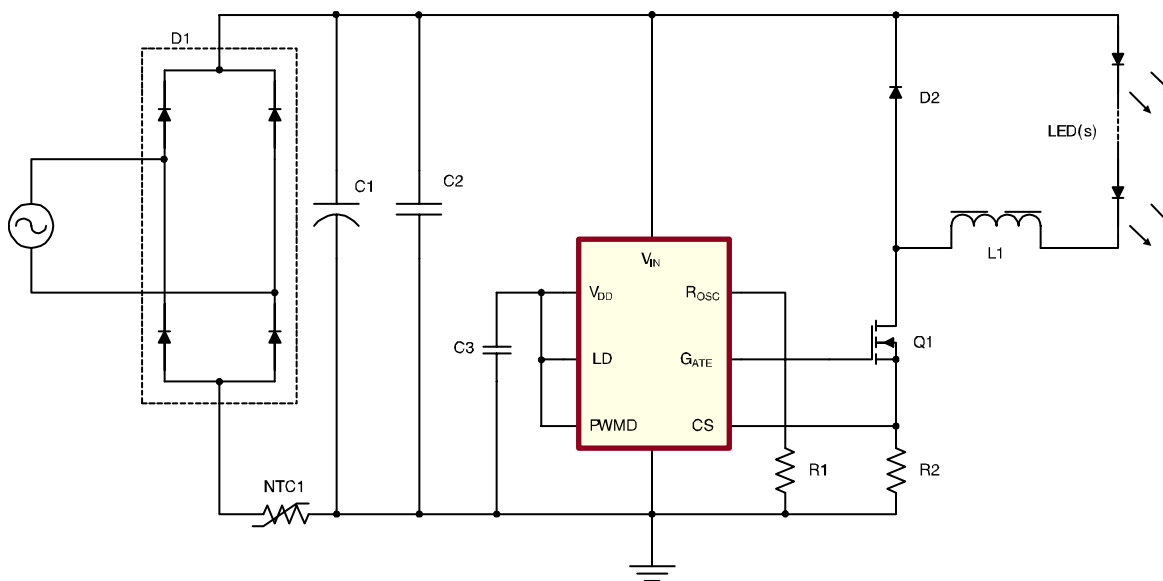

AC Input Voltage Range:	Expected LED string voltage	Stabilized LED current	Expected Efficiency
$V_{nom,ac} = 120V\ rms$	$V_{o,min} = 20V$	$I_{o,max} = 350mA$	$\eta = 0.9$
$V_{min,ac} = 90V\ rms$	$V_{o,max} = 40V$		
$V_{max,ac} = 135V\ rms$			
$freq = 60Hz$			

Step 1: Switching Frequency and resistor (R1)

The switching frequency determines the size of the inductor L1 and size or type of input filter capacitor C1. A larger switching frequency will result in a smaller inductor, but will increase the switching losses in the circuit. For off-Line applications, typical switching frequencies should be in range 20KHz-150KHz. The higher the input voltage range (for example in Europe 230VAC), the lower the frequency should be to avoid extensive capacitive losses in the converter. For North America AC line a frequency of $f_s = 100kHz$ is a good compromise.

From the datasheet, the oscillator resistor needed to achieve this is $228k\Omega$.

Step 2: Choose the Input Diode Bridge (D1) and the thermistor (NTC1)

The voltage rating of the diode bridge will depend on the maximum value of the input voltage. The current rating will depend on the maximum average current drawn by the converter.

$$V_{bridge} = 1.5 \times (\sqrt{2} \times V_{max,ac}) \quad (1)$$

$$I_{bridge} = \frac{V_{o,max} \times I_{o,max}}{V_{min,dc} \times \eta} \quad (2)$$

The 1.5 factor in equation (1) a 50% safety margin is more than enough. For this design, choose a 400V, 1A diode bridge.

Placing a thermistor (or resistor) in series with input bridge rectifier will effectively limit the inrush charging current to input bulk capacitor C1 during the initial start-up of the converter. Except this useful action during very short time interval, such a series element creates a unnecessary power loss dissipation during normal operation of the converter, and must be minimized. A good rule of thumb is that the thermistor should limit the inrush current to not more than five times the steady state current as given by equation (2), assuming maximum voltage is applied. The required cold resistance is:

$$R_{cold} = \frac{V_{bridge}}{5 \times I_{bridge}} \quad (3)$$

This gives us a 200Ω resistance at $25^\circ C$. Choose a thermistor with a resistance around 200Ω and rms current greater than 0.2A for that application.

Step 3: Choose the Input Capacitors (C1 and C2)

The first design criterion to meet is that the maximum LED string voltage is should be less than half the minimum input voltage to avoid having to implement a special loop compensation technique. For this example, the minimum rectified voltage should be:

$$V_{min,dc} = 2 \times V_{o,max} = 80V \quad (4)$$

The hold-up and input filter capacitor required at the the diode bridge output have to be calculated at the minimum AC input voltage. The minimum capacitor value can be calculated as:

$$C1 \geq \frac{V_{o,max} \times I_{o,max}}{\left(2 \times V_{min,ac}^2 - V_{min,dc}^2\right) \times \eta \times freq} \quad (5)$$

In this example, $C1 \geq 26.45\mu F$.

Note: Equation (5) yields a conservative estimate to for the least amount of capacitance required. It means that the capacitor filter will normally care large ripple content. Some electrolytic capacitors may not be able to withstand such ripple current and minimum value of C1 capacitor may not be met, forcing the design to use larger value capacitor. In the case where the allowable ripple at the input of the buck converter is large, the capacitor C1 can be reduced significantly. See the Appendix for a more accurate calculation of the required capacitor value.

The voltage rating of the capacitor should be more than the peak input voltage with 10-12% safety margin.

$$V_{max,cap} \geq \sqrt{2} \times V_{max,ac} \Rightarrow V_{max,cap} \geq 191V \quad (6)$$

Choose a $250V, 33\mu F$ electrolytic capacitor.

Application Note

AN-H48

Such electrolytic capacitor has sizable ESR component. The large ESR of these capacitors makes it inappropriate to absorb the high frequency ripple current generated by the buck converter. Thus, adding a small MLCC capacitor in parallel with the electrolytic capacitor is a good option to absorb the high frequency ripple current. The required high frequency capacitance can be computed as:

$$C2 = \frac{I_{o,max} \times 0.25}{f_s \times (0.05 \times V_{min,dc})} \quad (7)$$

In this design example, the high frequency capacitance required is about $0.22\mu F, 250V$.

Step 4: Choose the Inductor (L1)

The inductor value depends on the ripple current in the LEDs. Assume a +/- 15% ripple (a total of 30%) in the LED current, an aggressive assumption would go up to +/-30% to reduce the size of the inductor more than twice at the price of reduced efficiency and, possibly, reduced LED lifetime. Then, the inductor L1 can be computed at the rectified value of the nominal input voltage as:

$$L1 = \frac{V_{o,max} \times \left(1 - \frac{V_{o,max}}{\sqrt{2} \times V_{ac,nom}}\right)}{0.3 \times I_{o,max} \times f_s} \quad (8)$$

In this example,

$$L1 = 2.9mH$$

The peak current rating of the inductor will be

$$i_p = 0.35 \times 1.15 = 0.4A \quad (9)$$

The rms current through the inductor will be the same as the average current for the chosen 30% ripple.

Right inductor for this application is an off-the-shelf 2.7mH, 0.54A (peak), 0.33A (rms) inductor.

Step 5: Choose the FET (Q1) and Diode (D2)

The peak voltage seen by the FET is equal to the maximum input voltage. Using a 50% safety rating,

$$V_{FET} = 1.5 \times (\sqrt{2} \times 135) = 286V \quad (10)$$

The maximum rms current through the FET depends on the maximum duty cycle, which is 50% by design. Hence, the current rating of the FET is

$$I_{FET} \approx I_{o,max} \times \sqrt{0.5} = 0.247A \quad (11)$$

Typically a FET with about 3 times the current is chosen to minimize the resistive losses in the switch.

For this application, chose a MOSFET 300V, <1A, as BSP130 from Phillips. Actual MOSFET type should be determined by the transistor permitted power dissipation on printed board. For example,

BSP130 SOT-223 package limits the dissipation to less than a Watt at 50+ Celsius, even if the

MOSFET peak current capability is 1.5A. A good rule of thumb is to limit overall MOSFET power dissipation to not more than 3-5% of total output power, by making a right transistor choice. In choosing MOSFET transistors for such LED drivers, going bigger does not mean getting better, just the opposite. Using TO-220 transistor 500/4A/2Ω instead of SOT-223 transistor 300V/0.5A/6Ω does more harm than good, reducing overall efficiency by several percent.

The peak voltage rating of the diode is the same as the FET. Hence,

$$V_{diode} = V_{FET} = 286V \quad (12)$$

The average current through the diode is:

$$I_{diode} = 0.5 \times I_{o,max} = 0.175A \quad (13)$$

Choose a 300V, 1A ultra-fast diode.

Step 6: Choose the Sense Resistor (R2)

The sense resistor value is given by:

$$R2 = \frac{0.25}{1.15 \times I_{o,max}} \quad (14)$$

if the internal voltage threshold is being used. Otherwise, substitute the voltage at the LD pin instead of the 0.25V in equation (14).

For this design, $R2 = 0.55\Omega$. Calculate also resistor power dissipation:

$$P_{R2} = I_{o\max}^2 \times R2 = 0.067W$$

A 0.1W resistor is good for this application.

Note: Capacitor C3 is a bypass capacitor. A typical value of 1.0 to 2.2 μF , 16V is recommended.

Design for DC/DC Applications

The same procedure can be used for DC/DC applications (like the HV9910DB3). The only modifications are that the input diode bridge and input hold-up capacitor are not required. A small input capacitance to absorb high frequency ripple current is all that is required. This capacitance can be computed using equation (7).

Appendix

The more accurate equations for computing the required capacitance values are

$$t_1 = \frac{1}{2 \times \pi \times freq} \sin^{-1} \left(\frac{V_{\min, dc}}{\sqrt{2} \times V_{\min, ac}} \right)$$

$$C1 \geq \frac{2 \times V_{o, \max} \times I_{o, \max} \times \left(t_1 + \frac{1}{4 \times freq} \right)}{\left(2 \times V_{\min, ac}^2 - V_{\min, dc}^2 \right) \times \eta}$$

For the example in this application note, the actual minimum capacitance required from the above equations is 19 μF (as compared to 26 μF from equation (5)).

Supertex inc. does not recommend the use of its products in life support applications and will not knowingly sell its products for use in such applications unless it receives an adequate "products liability indemnification insurance agreement". **Supertex** does not assume responsibility for use of devices described and limits its liability to the replacement of the devices determined defective due to workmanship. No responsibility is assumed for possible omissions or inaccuracies. Circuitry and specifications are subject to change without notice. For the latest product specifications, refer to the **Supertex** website: <http://www.supertex.com>. For complete liability information on all **Supertex** products, refer to the most current databook or to the Legal/ Disclaimer page on the **Supertex** website.