

FET Input Power Operational Amplifier

FEATURES

- **LOW BIAS CURRENT** — FET Input
- **PROTECTED OUTPUT STAGE** — Thermal Shutoff
- **EXCELLENT LINEARITY** — Class A/B Output
- **WIDE SUPPLY RANGE** — ±12V TO ±50V
- **HIGH OUTPUT CURRENT** — ±5A Peak



**8-PIN TO-3
PACKAGE STYLE CE**

APPLICATIONS

- **MOTOR, VALVE AND ACTUATOR CONTROL**
- **MAGNETIC DEFLECTION CIRCUITS UP TO 4A**
- **POWER TRANSDUCERS UP TO 100kHz**
- **TEMPERATURE CONTROL UP TO 180W**
- **PROGRAMMABLE POWER SUPPLIES UP TO 90V**
- **AUDIO AMPLIFIERS UP TO 60W RMS**

DESCRIPTION

The PA07 is a high voltage, high output current operational amplifier designed to drive resistive, inductive and capacitive loads. For optimum linearity, especially at low levels, the output stage is biased for class A/B operation using a thermistor compensated base-emitter voltage multiplier circuit. A thermal shutoff circuit protects against overheating and minimizes heatsink requirements for abnormal operating conditions. The safe operating area (SOA) can be observed for all operating conditions by selection of user programmable current limiting resistors. Both amplifiers are internally compensated for all gain settings. For continuous operation under load, a heatsink of proper rating is recommended.

This hybrid circuit utilizes thick film (cermet) resistors, ceramic capacitors and semiconductor chips to maximize reliability, minimize size and give top performance. Ultrasonically bonded aluminum wires provide reliable interconnections at all operating temperatures. The 8-pin TO-3 package is hermetically sealed and electrically isolated. The use of compressible washers and/or improper mounting torque will void the product warranty. Please see "General Operating Considerations".

EQUIVALENT SCHEMATIC

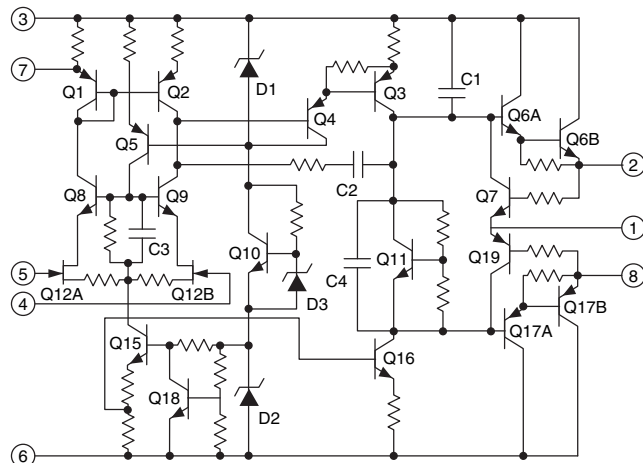

TYPICAL APPLICATION

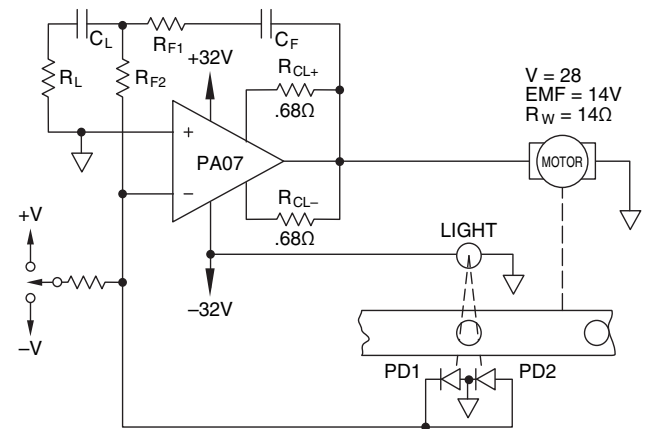

V = 28
EMF = 14V
R_w = 14Ω

Negates optoelectronic instabilities
Lead network minimizes overshoot
SEQUENTIAL POSITION CONTROL

Position is sensed by the differentially connected photo diodes, a method that negates the time and temperature variations of the optical components. Off center positions produce an error current which is integrated by the op amp circuit, driving the system back to center position. A momentary switch contact forces the system out of lock and then the integrating capacitor holds drive level while both diodes are in a dark state. When the next index point arrives, the lead network of C1 and R1 optimize system response by reducing overshoot. The very low bias current of the PA07 augments performance of the integrator circuit.

EXTERNAL CONNECTIONS

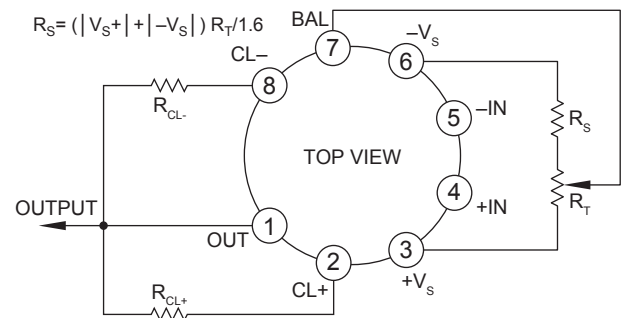

NOTE: Input offset voltage trim optional. R_T = 10KΩ MAX

ABSOLUTE MAXIMUM RATINGS

SUPPLY VOLTAGE, +V _S to -V _S	100V
OUTPUT CURRENT, within SOA	5A
POWER DISSIPATION, internal ¹	67W
INPUT VOLTAGE, differential	±50V
INPUT VOLTAGE, common mode	±V _S
TEMPERATURE, pin solder - 10s	300°C
TEMPERATURE, junction ¹	200°C
TEMPERATURE RANGE, storage	-65 to +150°C
OPERATING TEMPERATURE RANGE, case	-55 to +125°C

SPECIFICATIONS

PARAMETER	TEST CONDITIONS ²	PA07			PA07A			UNITS
		MIN	TYP	MAX	MIN	TYP	MAX	
INPUT								
OFFSET VOLTAGE, initial	T _C = 25°C		.5	±2		±.25	±.5	mV
OFFSET VOLTAGE, vs. temperature	Full temperature range		10	30		5	10	μV/°C
OFFSET VOLTAGE, vs. supply	T _C = 25°C		8			*		μV/V
OFFSET VOLTAGE, vs. power	Full temperature range		20			10		μV/W
BIAS CURRENT, initial ³	T _C = 25°C		5	50		3	10	pA
BIAS CURRENT, vs. supply	T _C = 25°C		.01			*		pA/V
OFFSET CURRENT, initial ³	T _C = 25°C		2.5	50		1.5	10	pA
INPUT IMPEDANCE, DC	T _C = 25°C		10 ¹¹			*		Ω
INPUT CAPACITANCE	T _C = 25°C		4			*		pF
COMMON MODE VOLTAGE RANGE ⁴	Full temperature range	±V _S -10			*			V
COMMON MODE REJECTION, DC	Full temperature range, V _{CM} = ±20V		120			*		dB
GAIN								
OPEN LOOP GAIN at 15Hz	T _C = 25°C, R _L = 15Ω	89	95		*	*		dB
GAIN BANDWIDTH PRODUCT @ 1MHz	T _C = 25°C, R _L = 15Ω		1.3			*		MHz
POWER BANDWIDTH	T _C = 25°C, R _L = 15Ω		18			*		kHz
PHASE MARGIN	Full temperature range, R _L = 15Ω		70			*		°
OUTPUT								
VOLTAGE SWING ⁴	Full temp. range, I _O = 5A	±V _S -5			*			V
VOLTAGE SWING ⁴	Full temp. range, I _O = 2A	±V _S -5			*			V
VOLTAGE SWING ⁴	Full temp. range, I _O = 90mA	±V _S -5			*			V
CURRENT, peak	T _C = 25°C	5			*			A
SETTLING TIME to .1%	T _C = 25°C, 2V step		1.5			*		μs
SLEW RATE	T _C = 25°C		5			*		V/μs
CAPACITIVE LOAD, unity gain	Full temperature range			1			*	nF
CAPACITIVE LOAD, gain>4	Full temperature range			SOA			*	
POWER SUPPLY								
VOLTAGE	Full temperature range	±12	±35	±50	*	*	*	V
CURRENT, quiescent	T _C = 25°C		18	30		*	*	mA
THERMAL								
RESISTANCE, AC, junction to case ⁵	F>60Hz		1.9	2.1		*	*	°C/W
RESISTANCE, DC, junction to case	F<60Hz		2.4	2.6		*	*	°C/W
RESISTANCE, junction to air			30			*	*	°C/W
TEMPERATURE RANGE, case	Meets full range specifications	-25	25	+85	*	*	*	°C

- NOTES: * The specification of PA07A is identical to the specification for PA07 in applicable column to the left.
1. Long term operation at the maximum junction temperature will result in reduced product life. Derate internal power dissipation to achieve high MTTF.
 2. The power supply voltage for all specifications is the TYP rating unless otherwise noted as a test condition.
 3. Doubles for every 10°C of temperature increase.
 4. +V_S and -V_S denote the positive and negative supply rail respectively. Total V_S is measured from +V_S to -V_S.
 5. Rating applies if the output current alternates between both output transistors at a rate faster than 60Hz.

CAUTION

The internal substrate contains beryllia (BeO). Do not break the seal. If accidentally broken, do not crush, machine, or subject to temperatures in excess of 850°C to avoid generating toxic fumes.

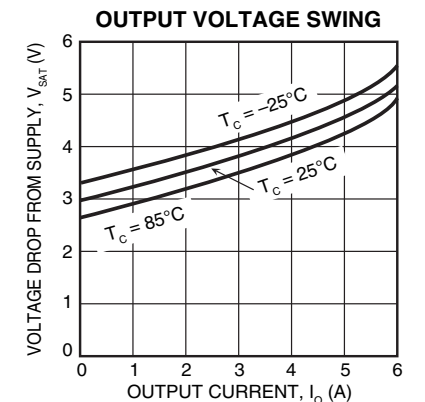
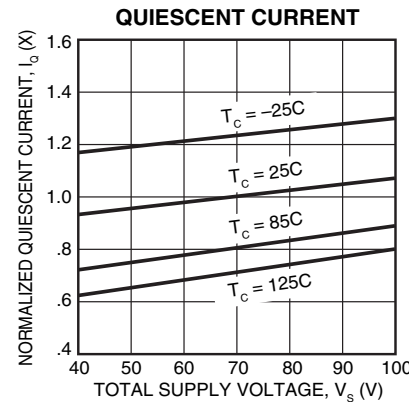
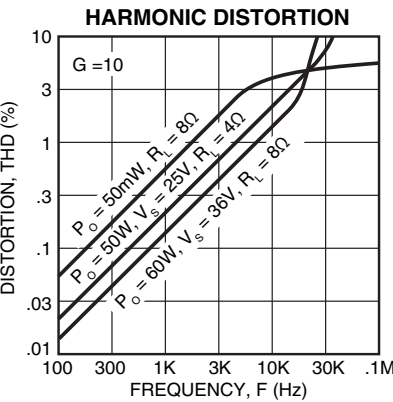
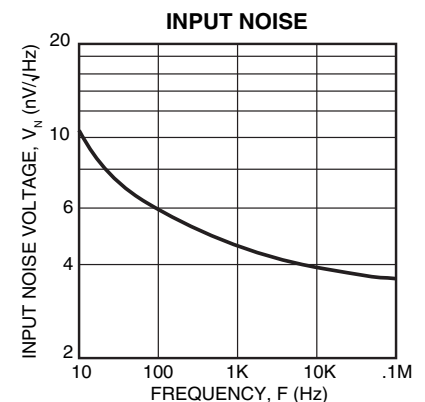
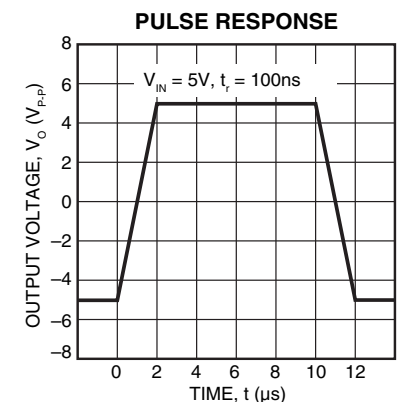
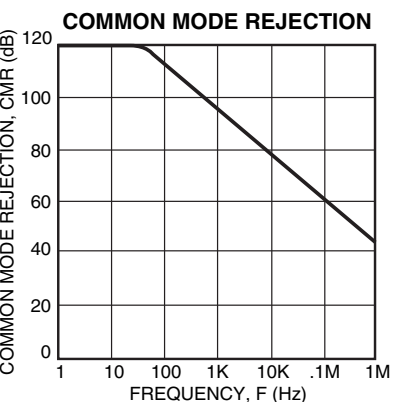
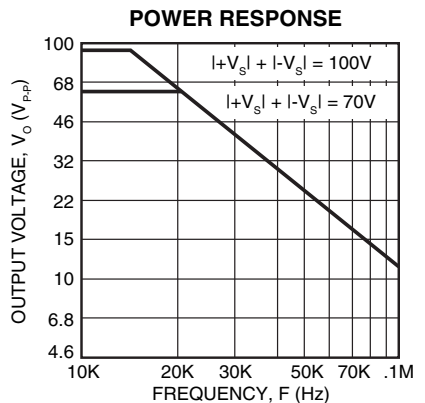
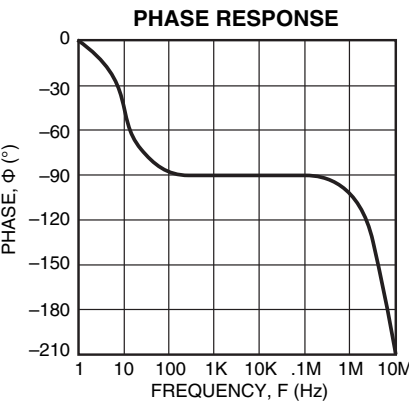
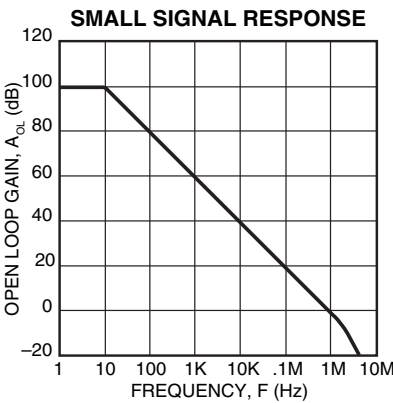
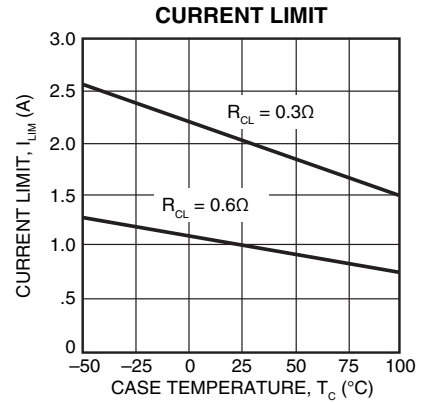
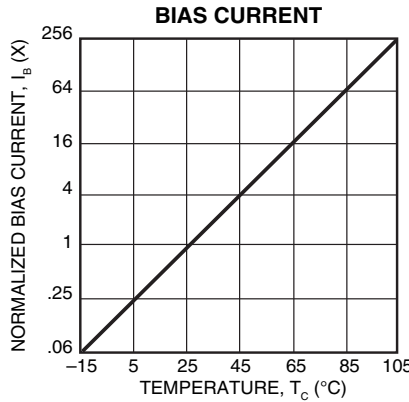
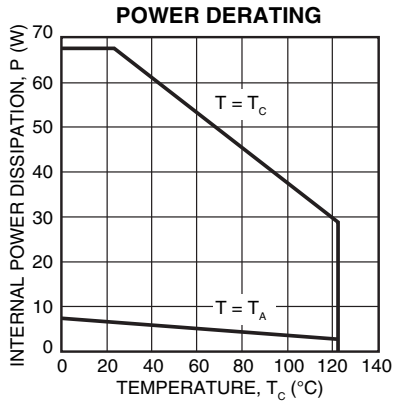

GENERAL

Please read Application Note 1 "General Operating Considerations" which covers stability, supplies, heat sinking, mounting, current limit, SOA interpretation, and specification interpretation. Visit www.Cirrus.com for design tools that help automate tasks such as calculations for stability, internal power dissipation, current limit; heat sink selection; Apex Precision Power's complete Application Notes library; Technical Seminar Workbook; and Evaluation Kits.

SAFE OPERATING AREA (SOA)

The output stage of most power amplifiers has three distinct limitations:

1. The current handling capability of the wire bonds.
2. The second breakdown effect which occurs whenever the simultaneous collector current and collector-emitter voltage exceed specified limits.
3. The junction temperature of the output transistors.

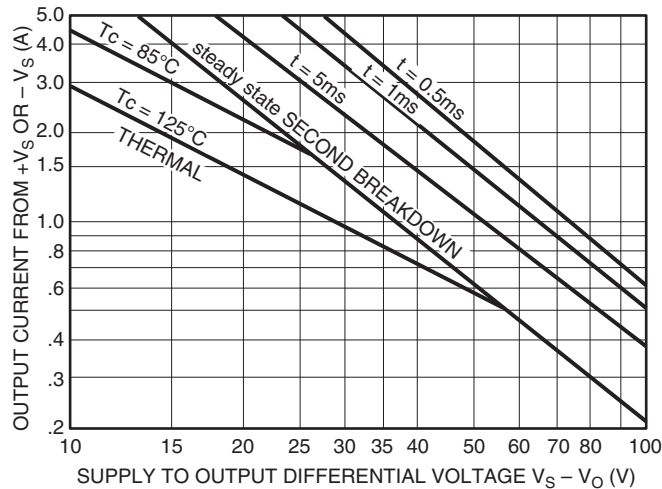

SAFE OPERATING AREA CURVES

The SOA curves combine the effect of these limits. For a given application, the direction and magnitude of the output current should be calculated or measured and checked against the SOA curves. This is simple for resistive loads but more complex for reactive and EMF generating loads. However, the following guidelines may save extensive analytical efforts.

1. For DC outputs, especially those resulting from fault conditions, check worst case stress levels against the SOA graph. Make sure the load line does not cross the 0.5ms limit and that excursions beyond any other second breakdown line do not exceed the time label, and have a duty cycle of no more than 10%.

A Spice type analysis can be very useful in that a hardware setup often calls for instruments or amplifiers with wide common mode rejection ranges. Please refer to Application Notes, AN01 and AN22 for detailed information regarding SOA considerations.

2. The amplifier can handle any reactive or EMF generating load and short circuits to the supply rail or common if the current limits are set as follows at $T_c = 85^\circ\text{C}$:

$\pm V_s$	SHORT TO $\pm V_s$ C, L, OR EMF LOAD	SHORT TO COMMON
50V	.21A	.61A
40V	.3A	.87A
30V	.46A	1.4A
20V	.87A	2.5A
15V	1.4A	4.0A

These simplified limits may be exceeded with further analysis using the operating conditions for a specific application.

3. The output stage is protected against transient flyback. However, for protection against sustained, high energy flyback, external fast-recovery diodes should be used.

THERMAL SHUTDOWN PROTECTION

The thermal protection circuit shuts off the amplifier when the substrate temperature exceeds approximately 150°C . This allows heatsink selection to be based on normal operating conditions while protecting the amplifier against excessive junction temperature during temporary fault conditions.

Thermal protection is a fairly slow-acting circuit and therefore does not protect the amplifier against transient SOA violations (areas outside of the $T_c = 25^\circ\text{C}$ boundary). It is designed to protect against short-term fault conditions that result in high power dissipation within the amplifier. If the conditions that cause thermal shutdown are not removed, the amplifier will oscillate in and out of shutdown. This will result in high peak power stresses, will destroy signal integrity and reduce the reliability of the device.

CURRENT LIMIT

Proper operation requires the use of two current limit resistors, connected as shown in the external connections diagram. The minimum value for R_{CL} is $.12\Omega$, however, for optimum reliability it should be set as high as possible. Refer to the "General Operating Considerations" section of the handbook for current limit adjust details.

CONTACTING CIRRUS LOGIC SUPPORT

For all Apex Precision Power product questions and inquiries, call toll free 800-546-2739 in North America.

For inquiries via email, please contact apex.support@cirrus.com.

International customers can also request support by contacting their local Cirrus Logic Sales Representative.

To find the one nearest to you, go to www.cirrus.com

IMPORTANT NOTICE

Cirrus Logic, Inc. and its subsidiaries ("Cirrus") believe that the information contained in this document is accurate and reliable. However, the information is subject to change without notice and is provided "AS IS" without warranty of any kind (express or implied). Customers are advised to obtain the latest version of relevant information to verify, before placing orders, that information being relied on is current and complete. All products are sold subject to the terms and conditions of sale supplied at the time of order acknowledgment, including those pertaining to warranty, indemnification, and limitation of liability. No responsibility is assumed by Cirrus for the use of this information, including use of this information as the basis for manufacture or sale of any items, or for infringement of patents or other rights of third parties. This document is the property of Cirrus and by furnishing this information, Cirrus grants no license, express or implied under any patents, mask work rights, copyrights, trademarks, trade secrets or other intellectual property rights. Cirrus owns the copyrights associated with the information contained herein and gives consent for copies to be made of the information only for use within your organization with respect to Cirrus integrated circuits or other products of Cirrus. This consent does not extend to other copying such as copying for general distribution, advertising or promotional purposes, or for creating any work for resale.

CERTAIN APPLICATIONS USING SEMICONDUCTOR PRODUCTS MAY INVOLVE POTENTIAL RISKS OF DEATH, PERSONAL INJURY, OR SEVERE PROPERTY OR ENVIRONMENTAL DAMAGE ("CRITICAL APPLICATIONS"). CIRRUS PRODUCTS ARE NOT DESIGNED, AUTHORIZED OR WARRANTED TO BE SUITABLE FOR USE IN PRODUCTS SURGICALLY IMPLANTED INTO THE BODY, AUTOMOTIVE SAFETY OR SECURITY DEVICES, LIFE SUPPORT PRODUCTS OR OTHER CRITICAL APPLICATIONS. INCLUSION OF CIRRUS PRODUCTS IN SUCH APPLICATIONS IS UNDERSTOOD TO BE FULLY AT THE CUSTOMER'S RISK AND CIRRUS DISCLAIMS AND MAKES NO WARRANTY, EXPRESS, STATUTORY OR IMPLIED, INCLUDING THE IMPLIED WARRANTIES OF MERCHANTABILITY AND FITNESS FOR PARTICULAR PURPOSE, WITH REGARD TO ANY CIRRUS PRODUCT THAT IS USED IN SUCH A MANNER. IF THE CUSTOMER OR CUSTOMER'S CUSTOMER USES OR PERMITS THE USE OF CIRRUS PRODUCTS IN CRITICAL APPLICATIONS, CUSTOMER AGREES, BY SUCH USE, TO FULLY INDEMNIFY CIRRUS, ITS OFFICERS, DIRECTORS, EMPLOYEES, DISTRIBUTORS AND OTHER AGENTS FROM ANY AND ALL LIABILITY, INCLUDING ATTORNEYS' FEES AND COSTS, THAT MAY RESULT FROM OR ARISE IN CONNECTION WITH THESE USES.

Cirrus Logic, Cirrus, and the Cirrus Logic logo designs, Apex Precision Power, Apex and the Apex Precision Power logo designs are trademarks of Cirrus Logic, Inc. All other brand and product names in this document may be trademarks or service marks of their respective owners.
