



S6E63D6

Rev.1.10

MOBILE DISPLAY DRIVER IC

Trademark & Copyright Information

Copyright © 2007-2007 Samsung Electronics Co., Ltd. All Rights Reserved.

This is proprietary information of Samsung Electronics Co., Ltd.

No part of the information contained in this document maybe reproduced or used without the prior consent of Samsung Electronics Co., Ltd.

Samsung reserves the right to make changes in its products or product specifications with the intent to improve function or design at any time and without notice and is not required to update this documentation to reflect such changes.

Samsung Electronics Co., Ltd.
San #24 Nongseo-Dong, Giheung-Gu,
Yongin-City, Gyeonggi-Do, Korea
446-711

<http://www.samsung.com/Products/Semiconductor/DisplayDriverIC>

IMPORTANT NOTICE!!

Precautions against Light

The conductivity of a semiconductor is strongly influenced by eletro-magnetic radiation such as visible light, infrared light, ultraviolet light, or gamma radiation. When light is absorbed, electron-hole pairs are generated raising the conductivity of the material, eventually altering the electrical characteristics of the IC. Therefore, if the packages that expose IC's to external light sources, such as COB, COG, TCP, and COF, are used, effective means to shield the IC from the light coming in all directions – top, bottom, and the sides – must be devised. Full observation of the following precautions is strongly recommended.

1. Make sure that the IC and substrate (board or glass) are protected from a stray light.
2. Always test and inspect products under the environment with no of light penetration.

Revision History

Ver.	Date	History
1.10	2007-09-10	- Change chip thickness in pad dimensions
1.00	2007-07-26	<ul style="list-style-type: none"> - Change technical specification format. - Change source output voltage range. 0.96 0.3V(16page) - Change the format of pad dimensions.(18page) - Change the default value of CLS from 0 to 1. - Change setting range of CLWEx.(53page) - Add the note about panel interface control.(54page) - Add the section of device code read.(55page) - Modify figure16. Pattern Diagram for Voltage Setting(89page) - Modify figure48. Timing Diagram of Register Read through SPI(104page) - Delete the section of display modes and gram access control, because it is duplicated.(110page) - Change set up flow of stand by.(150page) - Change source output voltage range. 0.96 0.3V(154page) - Add driving voltage (dVGH, dVGL). - Add current consumption during normal operation. - Add stand by mode current. - Add source output voltage deviation - Add source output voltage difference - Add output voltage deviation - Add MDDI I/O DC/AC characteristics.
0.20	2007-04-06	<ul style="list-style-type: none"> - Change S_RS, S_WRB in Tabel10: MDDI pad description - Add "Panel ITO must not cross all dummy pads" - Change BP, FP in Display Duty Control - Modify figure8. vertical scroll display - Change Gamma Amplitude Adjustment Setting in Table 54, 56, 57 - Change EL_ONOH, EL_ONOL in DC Characteristics - Update AC Characteristics - Update RGB data interface characteristics
0.10	2007-02-12	<ul style="list-style-type: none"> - R62h,R63h,R64h DK register is deleted. - R80h register is deleted. - Change VLOUT2 at BT<1:0>=10,11 - Change IM0/ID ID_MIB - Change VLOUT2 in DC Characteristics from 8.1 to 7.8
0.00	2007-01-18	- Initial Release for review

Contents

1. Introduction.....	15
1.1. Purpose of this document.....	15
2. Features.....	16
3. Block Diagram of IC.....	17
4. Pad Information	18
4.1. Pad Dimensions	18
4.2. Pad Arrangement Layout (TOP view).....	19
4.3. COG Align Key Coordinate	20
4.4. Pad Center Coordinates	21
5. I/O Signal Description.....	25
5.1. Power Supply Signals.....	25
5.2. System / RGB Interface Signals	27
5.3. MDDI Signals	29
5.4. Display Signals.....	30
5.5. Miscellaneous Signals.....	30
6. Function Description	31
6.1. System Interface	31
6.2. High Speed Serial Interface (MDDI).....	32
6.3. Sub Panel Control	32
6.4. External Interface (RGB I/F)	32
6.5. Address Counter (AC)	32
6.6. Graphics RAM (GRAM).....	32
6.7. Timing Generator	32
6.8. Grayscale Voltage Generator.....	32
6.9. Oscillation Circuit (OSC)	33
6.10. Source Driver Circuit	33
6.11. LTPS Panel Interface Circuit.....	33

6.12. GRAM Address Map	34
7. Instructions	35
7.1. Instruction Table	36
7.2. Instruction Descriptions.....	39
7.2.1. Index.....	39
7.2.2. Status Read.....	39
7.2.3. No Operation (R00h)	39
7.2.4. Display Duty Control (R01h).....	40
7.2.5. RGB Interface Control (R02h).....	42
7.2.6. Entry Mode (R03h).....	46
7.2.7. Clock Control (R04h).....	50
7.2.8. Display Control 1 (R05h).....	51
7.2.9. Display Control 2 (R06h).....	52
7.2.10. Panel Interface Control 1 (R07h, R08h).....	53
7.2.11. Panel Interface Control 2 (R09h)	54
7.2.12. Device Code Read (R0Fh).....	55
7.2.13. Stand By (R10h).....	55
7.2.14. Power GEN 1 (R12h)	56
7.2.15. Power GEN 2 (R13h)	57
7.2.16. Power GEN 3 (RF8h).....	58
7.2.17. Power GEN 4 (RF9h)	59
7.2.18. Power Booster Control (R14h)	60
7.2.19. Oscillator Control (R18h).....	61
7.2.20. Source Driver Control (R1Ah)	62
7.2.21. GRAM Address Set (R20h, R21h)	64
7.2.22. Write Data to GRAM (R22h).....	65
7.2.23. Read Data from FROM GRAM (R22h)	66
7.2.24. Select Data Bus 1 (R23h).....	67
7.2.25. Select Data Bus 2 (R24h).....	67

7.2.26. Vertical Scroll Control 1 (R30h, R31h)	68
7.2.27. Vertical Scroll Control 2 (R32h).....	70
7.2.28. Partial Screen Driving Position (R33h, R34h).....	72
7.2.29. Vertical RAM Address Position (R35h, R36h).....	74
7.2.30. Horizontal RAM Address Position (R37h).....	74
7.2.31. Client Initiated Wake up (R38h)	75
7.2.32. MDDI Link Wake up Start Position (R39h).....	75
7.2.33. Sub Panel Control 1 (R3Ah, R3Bh).....	76
7.2.34. Sub Panel Control 2 (R3Ch).....	77
7.2.35. Test Key Command (R60h).....	78
7.2.36. MTP Control (R61h)	78
7.2.37. MTP Register Setting (R62h, R63h, R64h, R65h).....	79
7.2.38. GPIO Control (R66h, R67h, R68h, R69h, R6Ah).....	84
7.2.39. Gamma Control (R70h to R78h)	86
7.2.40. EL Control (RF4h)	87
8. Reset Function.....	88
8.1. Instruction Set Initialization	88
9. Power Supply.....	89
9.1. Pattern Diagrams for Voltge Setting	89
9.2. Voltage Regulation Fuction	90
10. Interface Specification.....	91
10.1. System Interface	92
10.1.1. 68-system 18-bit Bus Interface.....	94
10.1.2. 68-system 16-bit Bus Interface.....	95
10.1.3. 68-system 9-bit Bus Interface.....	96
10.1.4. 68-system 8-bit Bus Interface.....	97
10.1.5. 80-system 18-bit Bus Interface.....	98
10.1.6. 80-system 16-bit Bus Interface.....	99
10.1.7. 80-system 9-bit Bus Interface.....	100

10.1.8. 80-system 8-bit Bus Interface.....	101
10.1.9. 68-/80-system 8-/9-bit Interface Synchronization Function.....	102
10.1.10. Serial Peripheral Interface.....	103
10.1.11. Index and Parameter Recognition.....	105
10.2. External Display Interface (RGB Interface)	106
10.2.1. 18-bit RGB Interface.....	107
10.2.2. 16-bit RGB Interface.....	107
10.2.3. 6-bit RGB Interface.....	108
10.2.4. Usage on External Display Interface.....	110
10.3. MDDI (Mobile Display Digital Interface)	111
10.3.1. Introduction of MDDI	111
10.3.2. DATA-STB Encoding.....	111
10.3.3. MDDI DATA / STB.....	112
10.3.4. Hibernation / Wake-up.....	113
10.3.5. MDDI Link Wake-up Procedure.....	114
10.3.6. GPIO Control	123
10.3.7. MDDI Packet	124
10.3.8. MDDI Operating State	128
10.3.9. Tearing-less Display	130
10.3.10. Sub Panel Control	131
11. AMOLED Panel Interface	138
11.1. AMOLED Panel Interface Signal	138
11.2. AMOLED Panel Interface Timing	139
12. R, G, B Independent Gamma Adjustment Function	140
12.1. Structure of Grayscale	141
12.2. R, G, B Independent Gamma Adjustment Registers.....	142
12.2.1. Amplitude Adjusting Registers	143
12.2.2. Curve Adjusting Registers.....	145
12.2.3. Curve Adjusting Block	146

12.3. 64 Gray Scale Output Voltage.....	147
12.4. Output Level as the function of GRAM Data.....	148
13. 8-Color Display Mode	149
14. Set-up Flow of Stand by	150
15. Oscillation Circuit.....	151
16. Application Circuit.....	152
17. DC / AC Specification	153
17.1. Absolute Maximum Rating.....	153
17.2. DC Characteristics.....	154
17.3. LTPS Panel Interface Signal Level Shifter Output Characteristics.....	156
17.4. Source Driver Output Characteristics	157
17.5. AC Characteristics.....	158
17.5.1. AC Characteristics on System Interface (Parallel 68 Mode).....	158
17.5.2. AC Characteristics on System Interface (Parallel 80 Mode).....	159
17.5.3. AC Characteristics on System Interface (SPI)	160
17.5.4. AC Characteristics on RGB Interface.....	161
17.6. MDDI IO DC / AC Characteristics.....	162
17.7. Reset Timing.....	163
17.8. External Power on / off Sequence.....	164
17.8.1. External Power On Sequence	164
17.8.2. External Power Off Sequence	164

Table Index

Table 1.	S6E63D6 Pad Dimensions	18
Table 2.	Pad Center Coordinates 1 [Unit : μm].....	21
Table 3.	Pad Center Coordinates 2 [Unit : μm].....	22
Table 4.	Pad Center Coordinates 3 [Unit : μm].....	23
Table 5.	Pad Center Coordinates 4 [Unit : μm].....	24
Table 6.	Power Supply Signal Description 1	25
Table 7.	Power Supply Signal Description 2	26
Table 8.	System / RGB Interface Signal Description 2	28
Table 9.	MDDI Signal Description	29
Table 10.	Display Signal Description	30
Table 11.	Miscellaneous Signal Description	30
Table 12.	Register Selection (18-/16-/9-/8- parallel interface)	31
Table 13.	CSB Signal (GRAM update control).....	31
Table 14.	Register Selection (Serial peripheral interface)	31
Table 15.	Instrunction Table 1	36
Table 16.	Instrunction Table 2	37
Table 17.	Instrunction Table 3	38
Table 18.	Blank Period Control with FP and BP	40
Table 19.	NL and Drive Duty.....	41
Table 20.	RM, DM, GRAM Access Interface and Display Operation Mode.....	43
Table 21.	RIM and RGB Interface Mode	43
Table 22.	Display Functions and Display Modes.....	44
Table 23.	Display State and Interface.....	44
Table 24.	VSPL and VSYNC.....	45
Table 25.	HSPL and VSYNC	45
Table 26.	EPL, ENABLE and RAM access	45
Table 27.	HSPL and VSYNC	45
Table 28.	Multiple Data Transfer Function 1.....	46
Table 29.	Multiple Data Transfer Function 2.....	47
Table 30.	Source Output Direction Control with SS (SS = "1")	48
Table 31.	Address Direction Setting	49
Table 32.	DCR and Division Ratio of DCCLK	50
Table 33.	Color Control by CL	52
Table 34.	REV and Source Output Level in Normal Display Area.....	52
Table 35.	CLWEx and the Intervals	53
Table 36.	SHE and the Latency of G_sw and B_sw.....	54
Table 37.	CLTE and the falling position of R_sw.....	54
Table 38.	The Setting of VCI1.....	56
Table 39.	The Setting of VINT	57
Table 40.	The Setting of VGH.....	58
Table 41.	The Setting of VGL	59

Table 42.	The Setting of DC2 and DC1	60
Table 43.	The Setting of BT	60
Table 44.	The Setting of RADJ	61
Table 45.	The Setting of GAMMA_TEST	62
Table 46.	The Setting of SDUM_ON	62
Table 47.	The Setting of SAP	63
Table 48.	GRAM Address Range	64
Table 49.	System Interface Mode	67
Table 50.	The setting of scroll start address	68
Table 51.	The setting of scroll end address	69
Table 52.	The setting of scroll end address	70
Table 53.	Restrictions on the Partial Screen Driving Position Register Setting	73
Table 54.	Sub Panel Interface Mode	77
Table 55.	The Setting of R(G, B)21_BT	79
Table 56.	The Setting of R(G, B)63_BT	80
Table 57.	The Setting of E_OST	80
Table 58.	MTP Writing Time	83
Table 59.	MTPG, MTPD Voltage Tolerance	83
Table 60.	System Interface Mode	92
Table 61.	Start Byte Format on SPI	103
Table 62.	RS an R/W Bit Function on SPI	103
Table 63.	Relationship between RIM and RGB Interface	106
Table 64.	Relationship between EPL and ENABLE	106
Table 65.	Display Function and External Display Interface	110
Table 66.	The Description of register for GPIO	123
Table 67.	MDDI Packet and Function	124
Table 68.	MDDI Operating State	128
Table 69.	Amplitude Adjusting Register	143
Table 70.	Relationship between Amplitude Adjusting Register and V0	143
Table 71.	Relationship between Amplitude Adjusting Register and V63	144
Table 72.	Gamma Curve Adjusting Register	145
Table 73.	Relationship between Value of Curve Adjusting Register and Voltage Dividing Ratio	146
Table 74.	Grayscale Output Voltage Formula	147
Table 75.	GRAM Data and Gray Scale Level	148
Table 76.	Example of Frame Frequency Calculation	151
Table 77.	Display Clock Frequency	151
Table 78.	Absolute Maximum rating	153
Table 79.	DC Characteristics 1	154
Table 80.	DC Characteristics 2	155
Table 81.	DC Characteristics 3	155
Table 82.	AC Chracteristics of Level shifter Outputs	156
Table 83.	AC Characteristics of Source Driver Output	157
Table 84.	Parallel Interface AC Characteristics (68 Mode)	158
Table 85.	Parallel Interface AC Characteristics (80 Mode)	159

Table 86.	SPI AC Characteristics.....	160
Table 87.	RGB Interface AC Characteristics	161
Table 88.	Data / Strobe Rx DC Characteristics.....	162
Table 89.	Data / Strobe Rx AC Characteristics.....	162
Table 90.	Driver Electrical DC Characteristics.....	162
Table 91.	AC characteristics (RESET timing).....	163
Table 92.	Reset Operation Regarding tRES Pulse Width.....	163

Figure Index

Figure 1.	Block Diagram of S6E63D6.....	17
Figure 2.	Pad Layout	19
Figure 3.	COG Align Key	20
Figure 4.	System / RGB Interface Signal Description 1	27
Figure 5.	GRAM Address (SS="0")	34
Figure 6.	GRAM Address (SS="1")	34
Figure 7.	The Waveform of TE Signal	52
Figure 8.	Memory Data Write Sequence	65
Figure 9.	Memory Data Read Sequence	66
Figure 10.	Vertical Scroll Display	71
Figure 11.	Driving On Partial Screen	73
Figure 12.	Window Address Function	74
Figure 13.	The Block diagram of sequence for V0, V21, V63 compensation.....	81
Figure 14.	MTP Initialization, Programing and Reading	82
Figure 15.	Timing of MTP Programing.....	83
Figure 16.	Pattern Diagram for Voltage Setting.....	89
Figure 17.	Voltage Regulation Function.....	90
Figure 18.	System Interface and RGB Interface	91
Figure 19.	8/9-bit Bus System	92
Figure 20.	18/16-bit Bus System	93
Figure 21.	Instruction Format for 68-system 18-bit Interface.....	94
Figure 22.	RAM Data Write Format for 68-system 18-bit Interface	94
Figure 23.	Timing Diagram of 68-system 18-bit Bus Interface.....	94
Figure 24.	Instruction Format for 68-system 16-bit Interface.....	95
Figure 25.	RAM Data Write Format for 68-system 16-bit Interface	95
Figure 26.	Timing Diagram of 68-system 16-bit Bus Interface.....	95
Figure 27.	Instruction Format for 68-system 9-bit Interface.....	96
Figure 28.	RAM Data Write Format for 68-system 9-bit Interface	96
Figure 29.	Timing Diagram of 68-system 9-bit Bus Interface.....	96
Figure 30.	Instruction Format for 68-system 8-bit Interface.....	97
Figure 31.	RAM Data Write Format for 68-system 8-bit Interface	97
Figure 32.	Timing Diagram of 68-System 8-Bit bus interface	97
Figure 33.	Instruction Format for 80-system 18-bit Interface.....	98
Figure 34.	RAM Data Write Format for 80-system 18-bit Interface	98
Figure 35.	Timing Diagram of 80-system 18-bit Bus Interface.....	98
Figure 36.	Instruction Format for 80-system 16-bit Interface.....	99
Figure 37.	RAM Data Write Format for 80-system 16-bit Interface	99
Figure 38.	Timing Diagram of 80-system 16-bit Bus Interface.....	99
Figure 39.	Instruction Format for 80-system 9-bit Interface.....	100
Figure 40.	RAM Data Write Format for 80-system 9-bit Interface	100
Figure 41.	Timing Diagram of 80-system 9-bit Bus Interface.....	100

Figure 42.	Instruction Format for 80-system 8-bit Interface.....	101
Figure 43.	RAM Data Write Format for 80-system 8-bit Interface	101
Figure 44.	Timing Diagram of 80-System 8-Bit bus interface	101
Figure 45.	8-/9-bit Interface Transfer Synchronization	102
Figure 46.	bit Assignment of Instructions on SPI	103
Figure 47.	timing diagram of Index Register Set through SPI	104
Figure 48.	Timing Diagram of Consecutive Register Data-Write through SPI	104
Figure 49.	Timing Diagram of Register Read through SPI	104
Figure 50.	Index and Parameter Recognition with 8-/9-bit Interface	105
Figure 51.	Index and Parameter Recognition with 18-/16-bit Interface	105
Figure 52.	Bit Assignment of GRAM on 18-bit RGB Interface.....	107
Figure 53.	Bit Assignment of GRAM on 16-bit RGB Interface.....	107
Figure 54.	Timing Diagram of 18-/16-bit RGB Interface.....	107
Figure 55.	Bit Assignment of GRAM on 6-bit RGB Interface.....	108
Figure 56.	Timing Diagram of 6-bit RGB Interface	108
Figure 57.	Transfer Synchronization Function on 6-bit RGB Interface mode	109
Figure 58.	Physical Connection of MDDI Host and Client	111
Figure 59.	DATA-STB Encoding.....	111
Figure 60.	DATA / STB Generation & Recovery Circuit.....	112
Figure 61.	Differential Connection between Host and Client	112
Figure 62.	MDDI Transceiver / Receiver State in Hibernation	113
Figure 63.	Process from Entering Hibernation to Exiting Hibernation	115
Figure 64.	Host-initiated Link Wake-up Procedure	116
Figure 65.	Host-initiated Link Wake-up Sequence	117
Figure 66.	Host-initiated Wake-up Process from Hibernation with Connection from Client	118
Figure 67.	Client-initiated Link Wake-up Procedure	119
Figure 68.	Client-initiated Link Wake-up Sequence	120
Figure 69.	VSYNC Based Link Wake-up Procedure	121
Figure 70.	GPIO Based Link Wake-up Procedure	122
Figure 71.	MDDI Packet Structure.....	124
Figure 72.	Sub-frame Header Packet Structure.....	125
Figure 73.	Register Access Packet Structure	125
Figure 74.	Video Stream Packet Structure	126
Figure 75.	Filler Packet Structure	126
Figure 76.	Link Shutdown Packet Structure	127
Figure 77.	Operating State in MDDI mode.....	129
Figure 78.	Tearing-less Display: Display speed is faster than data write.....	130
Figure 79.	Tearing-less Display: Data write speed is faster than display.....	130
Figure 80.	Schematic Diagram of Sub Panel Control Function	131
Figure 81.	Main / Sub Panel Selection Procedure	132
Figure 82.	80 Mode TFT Type 9-/8-bit Register Access Data Transfer	133
Figure 83.	80 Mode TFT Type 9-bit Video Data Transfer	134
Figure 84.	80 Mode TFT Type 8-bit Video Data Transfer	134
Figure 85.	80 Mode STN Type Convnetional Register Data Transfer	135

Figure 86.	80 mode STN Type Register Data Included Parameter Transfer	135
Figure 87.	80 Mode STN Type 16-bit Video Data Transfer	136
Figure 88.	80 Mode STN Type 8-bit Video Data Transfer	136
Figure 89.	Index/parameter Write for Sub Panel DDI	137
Figure 90.	Image Data Write for Sub Panel DDI	137
Figure 91.	Change Data Path from Sub Panel to Main Panel	137
Figure 92.	An Exemplary Combination of AMOLED Panel and DDI	138
Figure 93.	Timing Diagram of Panel Interface Signals	139
Figure 94.	VSYNC and Panel Interface Signals in External Clock Operation Mode	139
Figure 95.	Grayscale Control.....	140
Figure 96.	Structure of Grayscale.....	141
Figure 97.	The Operation of Adjusting Register.....	142
Figure 98.	Gamma Curve Adjustment	145
Figure 99.	Relationship between RAM Data and Output Voltage	148
Figure 100.	8-color Display Control	149
Figure 101.	Set-up Flow of Stand by.....	150
Figure 102.	Formula for the Frame Frequency	151
Figure 103.	S6E63D6 Application Circuit (80 System CPU Parallel Interface)	152
Figure 104.	AC Characteristics of Level Shifter Output	156
Figure 105.	LTPS Signal Load Test Point.....	156
Figure 106.	AC Characteristics of Source Driver Output	157
Figure 107.	AC Characteristics (68 Mode).....	158
Figure 108.	AC Characteristics (80 Mode).....	159
Figure 109.	AC Characteristics (SPI Mode).....	160
Figure 110.	AC Characteristics (RGB Interface Mode)	161
Figure 111.	AC characteristics (RESET timing).....	163
Figure 112.	Spike Rejection During a Valid Reset Pulse.....	163
Figure 113.	External Power on Sequence	164
Figure 114.	External Power off Sequence	164

1. Introduction

1.1. Purpose of this document

This document is to provide a complete reference specification of S6E63D6. Based on this reference specification, IC design engineers could design the IC, and test engineers test the compliance of the manufactured IC to guarantee the performance, and application engineers assist the customers to make sure that the customer use this IC properly.

The S6E63D6 is a single chip solution for Gate-IC-less AMOLED panel. Source driver with built-in memory, gate-IC-less level shifter and power circuits are integrated on this LSI. It can display to the maximum of 240-RGB x 320-dot graphics on 260k-color AMOLED panel. Moreover, the chip supports LTPS panel.

2. Features

S6E63D6 offers the following key features:

- 240-RGBx320-dot AM-OLED display controller/driver IC for 262,144 colors
- Gateless IC
- 240 channel source driver with time shared driving function
- 262,144 colors can be displayed at the same time with RGB separated gamma adjust.
- 262,144 / 65,536/ 8 colors can be displayed.
- 18-/16-/9-/8-bit high-speed parallel bus interface (80- and 68- system)
- Serial peripheral interface (SPI)
- 18-/16-/6-bit RGB interface
- MDDI (Mobile Display Digital Interface) support
- Internal ram capacity: $240 \times 18 \times 320 = 1,382,400$ bits
- Writing to a window-ram address area by using a window-address function
- Internal power supply circuit
- I/O power-supply VDD3 to VSS = 1.65 to 3.3V
- Analog power-supply VCI to VSS = 2.5 to 3.3V
- VGH = 3.0 to 8.0V (gate circuit power supply)
- VGL = -8.0 to -3.0V (gate circuit power supply)
- VINT = - 4.0 to -1.0V (OLED pixel initialization first power supply)
- Source output range = 0.3 to 4.2V
- S6E63D6 is released COG type package format only.

3. Block Diagram of IC

Figure 1 shows the block diagram of S6E63D6.

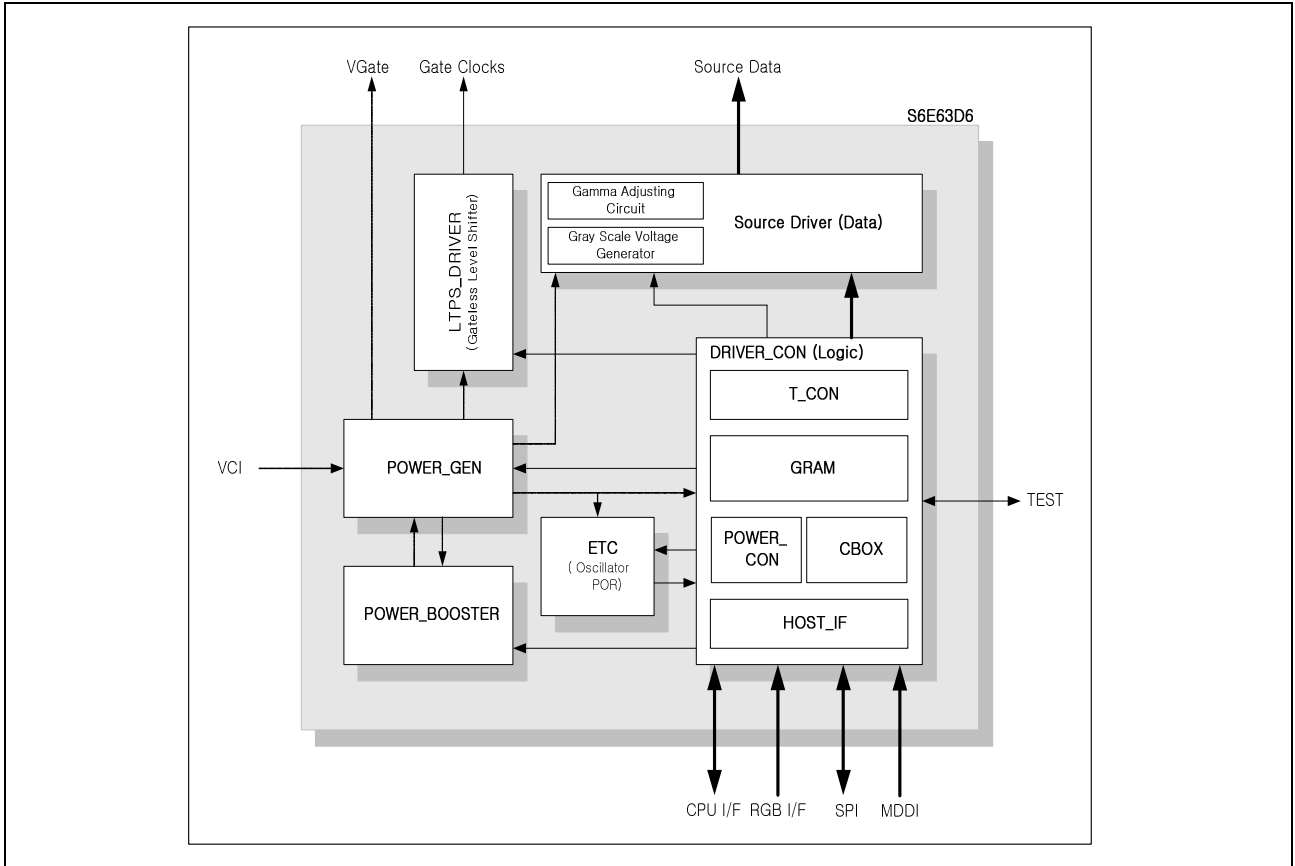

Figure 1. Block Diagram of S6E63D6

4. Pad Information

This chapter provides general information about pads for a display modul manufacturer.

4.1. Pad Dimensions

Table 1. S6E63D6 Pad Dimensions

Item	Pad Type	Size		Unit
		X	Y	
Die size ⁽¹⁾	-	15,580	1,330	μm
Pad pitch	Input Pad	60		
	Output Pad	54		
Bumped Pad top size	Input Pad (1-251)	30±2	91±2	
	Output Pad (264-539)	36±2	91±2	
	Output Pad (252-263, 540-551)	91±2	36±2	
Bumped pad height	In Wafer	15±3		
Chip Thickness	-	300±10 ⁽²⁾		

- [NOTE]**
1. Scribe lane included in this chip size (Scribe lane [width]: 80 μm)
 2. Chip thickness can be varies based on the customer's need.

4.2. Pad Arrangement Layout (TOP view)

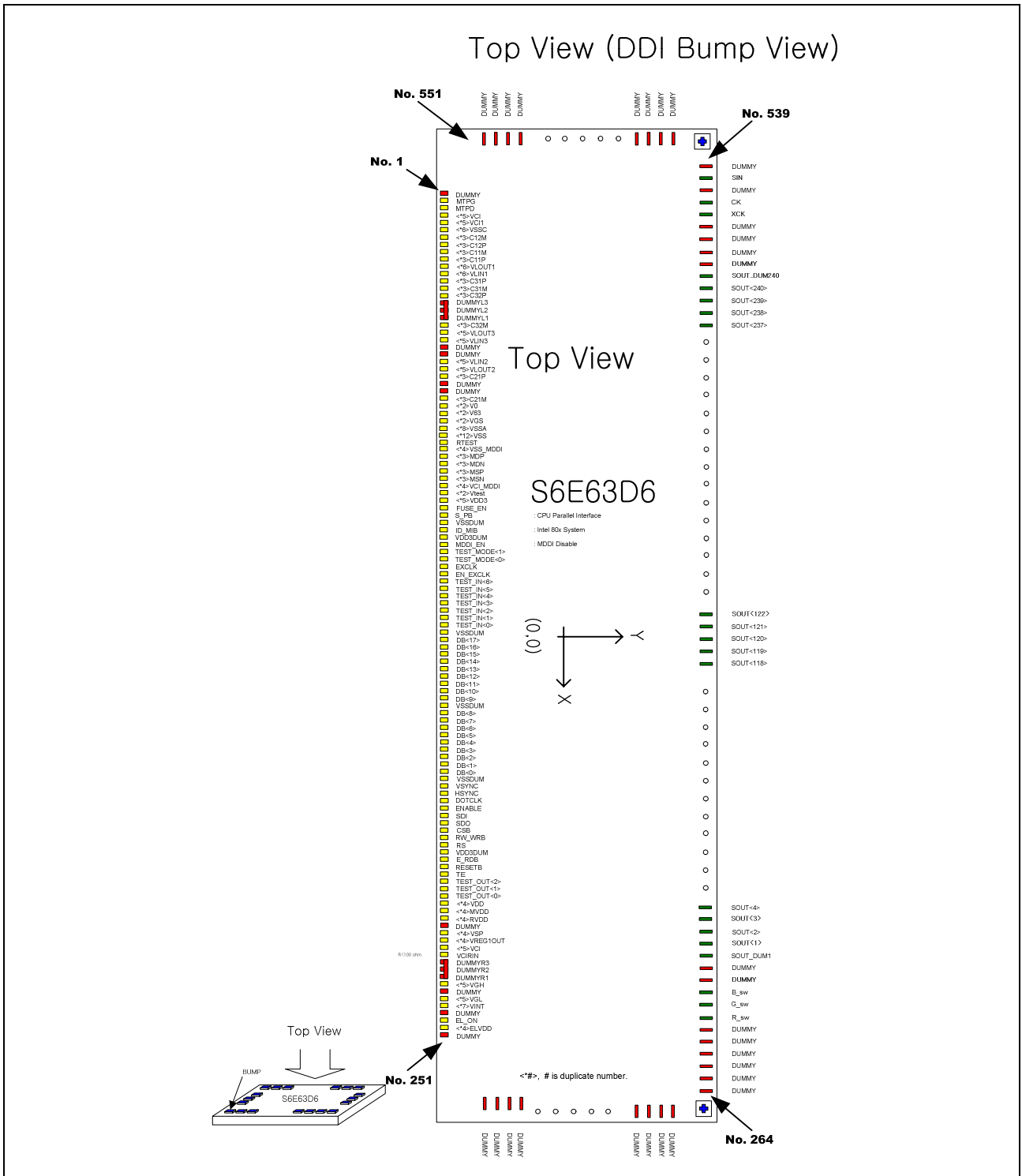

Figure 2. Pad Layout

4.3. COG Align Key Coordinate

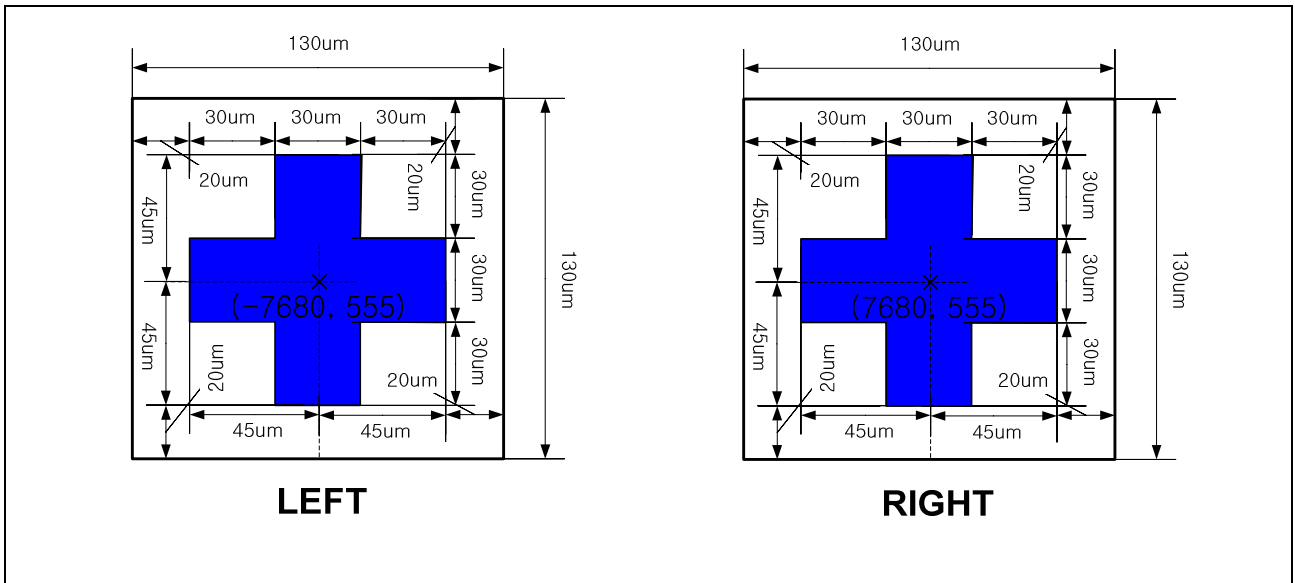

Figure 3. COG Align Key

4.4. Pad Center Coordinates

Table 2. Pad Center Coordinates 1 [Unit : μm]

NO	NAME	X	Y	NO	NAME	X	Y	NO	NAME	X	Y
1	DUMMY	-7500.0	-572.5	51	C32P	-4500.0	-572.5	101	VSSA	-1500.0	-572.5
2	MTPG	-7440.0	-572.5	52	C32P	-4440.0	-572.5	102	VSSA	-1440.0	-572.5
3	MTPD	-7380.0	-572.5	53	DUMMYL3	-4380.0	-572.5	103	VSS	-1380.0	-572.5
4	VCI	-7320.0	-572.5	54	DUMMYL2	-4320.0	-572.5	104	VSS	-1320.0	-572.5
5	VCI	-7260.0	-572.5	55	DUMMYL1	-4260.0	-572.5	105	VSS	-1260.0	-572.5
6	VCI	-7200.0	-572.5	56	C32M	-4200.0	-572.5	106	VSS	-1200.0	-572.5
7	VCI	-7140.0	-572.5	57	C32M	-4140.0	-572.5	107	VSS	-1140.0	-572.5
8	VCI	-7080.0	-572.5	58	C32M	-4080.0	-572.5	108	VSS	-1080.0	-572.5
9	VCI1	-7020.0	-572.5	59	VLOUT3	-4020.0	-572.5	109	VSS	-1020.0	-572.5
10	VCI1	-6960.0	-572.5	60	VLOUT3	-3960.0	-572.5	110	VSS	-960.0	-572.5
11	VCI1	-6900.0	-572.5	61	VLOUT3	-3900.0	-572.5	111	VSS	-900.0	-572.5
12	VCI1	-6840.0	-572.5	62	VLOUT3	-3840.0	-572.5	112	VSS	-840.0	-572.5
13	VCI1	-6780.0	-572.5	63	VLOUT3	-3780.0	-572.5	113	VSS	-780.0	-572.5
14	VSSC	-6720.0	-572.5	64	VLIN3	-3720.0	-572.5	114	VSS	-720.0	-572.5
15	VSSC	-6660.0	-572.5	65	VLIN3	-3660.0	-572.5	115	RTEST	-660.0	-572.5
16	VSSC	-6600.0	-572.5	66	VLIN3	-3600.0	-572.5	116	VSS_MDDI	-600.0	-572.5
17	VSSC	-6540.0	-572.5	67	VLIN3	-3540.0	-572.5	117	VSS_MDDI	-540.0	-572.5
18	VSSC	-6480.0	-572.5	68	VLIN3	-3480.0	-572.5	118	VSS_MDDI	-480.0	-572.5
19	VSSC	-6420.0	-572.5	69	DUMMY	-3420.0	-572.5	119	VSS_MDDI	-420.0	-572.5
20	C12M	-6360.0	-572.5	70	DUMMY	-3360.0	-572.5	120	MDP	-360.0	-572.5
21	C12M	-6300.0	-572.5	71	VLIN2	-3300.0	-572.5	121	MDP	-300.0	-572.5
22	C12M	-6240.0	-572.5	72	VLIN2	-3240.0	-572.5	122	MDP	-240.0	-572.5
23	C12P	-6180.0	-572.5	73	VLIN2	-3180.0	-572.5	123	MDN	-180.0	-572.5
24	C12P	-6120.0	-572.5	74	VLIN2	-3120.0	-572.5	124	MDN	-120.0	-572.5
25	C12P	-6060.0	-572.5	75	VLIN2	-3060.0	-572.5	125	MDN	-60.0	-572.5
26	C11M	-6000.0	-572.5	76	VLOUT2	-3000.0	-572.5	126	MSP	0.0	-572.5
27	C11M	-5940.0	-572.5	77	VLOUT2	-2940.0	-572.5	127	MSP	60.0	-572.5
28	C11M	-5880.0	-572.5	78	VLOUT2	-2880.0	-572.5	128	MSP	120.0	-572.5
29	C11P	-5820.0	-572.5	79	VLOUT2	-2820.0	-572.5	129	MSN	180.0	-572.5
30	C11P	-5760.0	-572.5	80	VLOUT2	-2760.0	-572.5	130	MSN	240.0	-572.5
31	C11P	-5700.0	-572.5	81	C21P	-2700.0	-572.5	131	MSN	300.0	-572.5
32	VLOUT1	-5640.0	-572.5	82	C21P	-2640.0	-572.5	132	VCI_MDDI	360.0	-572.5
33	VLOUT1	-5580.0	-572.5	83	C21P	-2580.0	-572.5	133	VCI_MDDI	420.0	-572.5
34	VLOUT1	-5520.0	-572.5	84	DUMMY	-2520.0	-572.5	134	VCI_MDDI	480.0	-572.5
35	VLOUT1	-5460.0	-572.5	85	DUMMY	-2460.0	-572.5	135	VCI_MDDI	540.0	-572.5
36	VLOUT1	-5400.0	-572.5	86	C21M	-2400.0	-572.5	136	Vtest	600.0	-572.5
37	VLOUT1	-5340.0	-572.5	87	C21M	-2340.0	-572.5	137	Vtest	660.0	-572.5
38	VLIN1	-5280.0	-572.5	88	C21M	-2280.0	-572.5	138	VDD3	720.0	-572.5
39	VLIN1	-5220.0	-572.5	89	V0	-2220.0	-572.5	139	VDD3	780.0	-572.5
40	VLIN1	-5160.0	-572.5	90	V0	-2160.0	-572.5	140	VDD3	840.0	-572.5
41	VLIN1	-5100.0	-572.5	91	V63	-2100.0	-572.5	141	VDD3	900.0	-572.5
42	VLIN1	-5040.0	-572.5	92	V63	-2040.0	-572.5	142	VDD3	960.0	-572.5
43	VLIN1	-4980.0	-572.5	93	VGS	-1980.0	-572.5	143	FUSE_EN	1020.0	-572.5
44	C31P	-4920.0	-572.5	94	VGS	-1920.0	-572.5	144	S_PB	1080.0	-572.5
45	C31P	-4860.0	-572.5	95	VSSA	-1860.0	-572.5	145	VSSDUM	1140.0	-572.5
46	C31P	-4800.0	-572.5	96	VSSA	-1800.0	-572.5	146	ID_MIB	1200.0	-572.5
47	C31M	-4740.0	-572.5	97	VSSA	-1740.0	-572.5	147	VDD3DUM	1260.0	-572.5
48	C31M	-4680.0	-572.5	98	VSSA	-1680.0	-572.5	148	MDDI_EN	1320.0	-572.5
49	C31M	-4620.0	-572.5	99	VSSA	-1620.0	-572.5	149	TEST_MODE[1]	1380.0	-572.5
50	C32P	-4560.0	-572.5	100	VSSA	-1560.0	-572.5	150	TEST_MODE[0]	1440.0	-572.5

Table 3. Pad Center Coordinates 2 [Unit : μm]

NO	NAME	X	Y	NO	NAME	X	Y	NO	NAME	X	Y
151	EXCLK	1500.0	-572.5	201	MVDD	4500.0	-572.5	251	DUMMY	7500.0	-572.5
152	EN_EXCLK	1560.0	-572.5	202	MVDD	4560.0	-572.5	252	DUMMY	7697.5	-296.0
153	TEST_IN[6]	1620.0	-572.5	203	MVDD	4620.0	-572.5	253	DUMMY	7697.5	-242.0
154	TEST_IN[5]	1680.0	-572.5	204	MVDD	4680.0	-572.5	254	DUMMY	7697.5	-188.0
155	TEST_IN[4]	1740.0	-572.5	205	RVDD	4740.0	-572.5	255	DUMMY	7697.5	-134.0
156	TEST_IN[3]	1800.0	-572.5	206	RVDD	4800.0	-572.5	256	DUMMY	7697.5	-80.0
157	TEST_IN[2]	1860.0	-572.5	207	RVDD	4860.0	-572.5	257	DUMMY	7697.5	-26.0
158	TEST_IN[1]	1920.0	-572.5	208	RVDD	4920.0	-572.5	258	DUMMY	7697.5	28.0
159	TEST_IN[0]	1980.0	-572.5	209	DUMMY	4980.0	-572.5	259	DUMMY	7697.5	82.0
160	VSSDUM	2040.0	-572.5	210	VSP	5040.0	-572.5	260	DUMMY	7697.5	136.0
161	DB17	2100.0	-572.5	211	VSP	5100.0	-572.5	261	DUMMY	7697.5	190.0
162	DB16	2160.0	-572.5	212	VSP	5160.0	-572.5	262	DUMMY	7697.5	244.0
163	DB15	2220.0	-572.5	213	VSP	5220.0	-572.5	263	DUMMY	7697.5	298.0
164	DB14	2280.0	-572.5	214	VREG1OUT	5280.0	-572.5	264	DUMMY	7425.0	572.5
165	DB13	2340.0	-572.5	215	VREG1OUT	5340.0	-572.5	265	DUMMY	7371.0	572.5
166	DB12	2400.0	-572.5	216	VREG1OUT	5400.0	-572.5	266	DUMMY	7317.0	572.5
167	DB11	2460.0	-572.5	217	VREG1OUT	5460.0	-572.5	267	DUMMY	7263.0	572.5
168	DB10	2520.0	-572.5	218	VCI	5520.0	-572.5	268	DUMMY	7209.0	572.5
169	DB9	2580.0	-572.5	219	VCI	5580.0	-572.5	269	DUMMY	7155.0	572.5
170	VSSDUM	2640.0	-572.5	220	VCI	5640.0	-572.5	270	DUMMY	7101.0	572.5
171	DB8	2700.0	-572.5	221	VCI	5700.0	-572.5	271	DUMMY	7047.0	572.5
172	DB7	2760.0	-572.5	222	VCI	5760.0	-572.5	272	DUMMY	6993.0	572.5
173	DB6	2820.0	-572.5	223	VCIRIN	5820.0	-572.5	273	DUMMY	6939.0	572.5
174	DB5	2880.0	-572.5	224	DUMMYR3	5880.0	-572.5	274	DUMMY	6885.0	572.5
175	DB4	2940.0	-572.5	225	DUMMYR2	5940.0	-572.5	275	R_sw	6831.0	572.5
176	DB3	3000.0	-572.5	226	DUMMYR1	6000.0	-572.5	276	R_sw	6777.0	572.5
177	DB2	3060.0	-572.5	227	VGH	6060.0	-572.5	277	G_sw	6723.0	572.5
178	DB1	3120.0	-572.5	228	VGH	6120.0	-572.5	278	G_sw	6669.0	572.5
179	DB0	3180.0	-572.5	229	VGH	6180.0	-572.5	279	B_sw	6615.0	572.5
180	VSSDUM	3240.0	-572.5	230	VGH	6240.0	-572.5	280	B_sw	6561.0	572.5
181	VSYNC	3300.0	-572.5	231	VGH	6300.0	-572.5	281	DUMMY	6507.0	572.5
182	HSYNC	3360.0	-572.5	232	DUMMY	6360.0	-572.5	282	DUMMY	6453.0	572.5
183	DOTCLK	3420.0	-572.5	233	VGL	6420.0	-572.5	283	SOUT_DUM1	6399.0	572.5
184	ENABLE	3480.0	-572.5	234	VGL	6480.0	-572.5	284	SOUT[1]	6345.0	572.5
185	SDI	3540.0	-572.5	235	VGL	6540.0	-572.5	285	SOUT[2]	6291.0	572.5
186	SDO	3600.0	-572.5	236	VGL	6600.0	-572.5	286	SOUT[3]	6237.0	572.5
187	CSB	3660.0	-572.5	237	VGL	6660.0	-572.5	287	SOUT[4]	6183.0	572.5
188	RW_WRB	3720.0	-572.5	238	VINT	6720.0	-572.5	288	SOUT[5]	6129.0	572.5
189	RS	3780.0	-572.5	239	VINT	6780.0	-572.5	289	SOUT[6]	6075.0	572.5
190	VDD3DUM	3840.0	-572.5	240	VINT	6840.0	-572.5	290	SOUT[7]	6021.0	572.5
191	E_RDB	3900.0	-572.5	241	VINT	6900.0	-572.5	291	SOUT[8]	5967.0	572.5
192	RESETB	3960.0	-572.5	242	VINT	6960.0	-572.5	292	SOUT[9]	5913.0	572.5
193	TE	4020.0	-572.5	243	VINT	7020.0	-572.5	293	SOUT[10]	5859.0	572.5
194	TEST_OUT[2]	4080.0	-572.5	244	VINT	7080.0	-572.5	294	SOUT[11]	5805.0	572.5
195	TEST_OUT[1]	4140.0	-572.5	245	DUMMY	7140.0	-572.5	295	SOUT[12]	5751.0	572.5
196	TEST_OUT[0]	4200.0	-572.5	246	EL_ON	7200.0	-572.5	296	SOUT[13]	5697.0	572.5
197	VDD	4260.0	-572.5	247	ELVDD	7260.0	-572.5	297	SOUT[14]	5643.0	572.5
198	VDD	4320.0	-572.5	248	ELVDD	7320.0	-572.5	298	SOUT[15]	5589.0	572.5
199	VDD	4380.0	-572.5	249	ELVDD	7380.0	-572.5	299	SOUT[16]	5535.0	572.5
200	VDD	4440.0	-572.5	250	ELVDD	7440.0	-572.5	300	SOUT[17]	5481.0	572.5

Table 4. Pad Center Coordinates 3 [Unit : μm]

NO	NAME	X	Y	NO	NAME	X	Y	NO	NAME	X	Y
301	SOUT[18]	5427.0	572.5	351	SOUT[68]	2727.0	572.5	401	SOUT[118]	27.0	572.5
302	SOUT[19]	5373.0	572.5	352	SOUT[69]	2673.0	572.5	402	SOUT[119]	-27.0	572.5
303	SOUT[20]	5319.0	572.5	353	SOUT[70]	2619.0	572.5	403	SOUT[120]	-81.0	572.5
304	SOUT[21]	5265.0	572.5	354	SOUT[71]	2565.0	572.5	404	SOUT[121]	-135.0	572.5
305	SOUT[22]	5211.0	572.5	355	SOUT[72]	2511.0	572.5	405	SOUT[122]	-189.0	572.5
306	SOUT[23]	5157.0	572.5	356	SOUT[73]	2457.0	572.5	406	SOUT[123]	-243.0	572.5
307	SOUT[24]	5103.0	572.5	357	SOUT[74]	2403.0	572.5	407	SOUT[124]	-297.0	572.5
308	SOUT[25]	5049.0	572.5	358	SOUT[75]	2349.0	572.5	408	SOUT[125]	-351.0	572.5
309	SOUT[26]	4995.0	572.5	359	SOUT[76]	2295.0	572.5	409	SOUT[126]	-405.0	572.5
310	SOUT[27]	4941.0	572.5	360	SOUT[77]	2241.0	572.5	410	SOUT[127]	-459.0	572.5
311	SOUT[28]	4887.0	572.5	361	SOUT[78]	2187.0	572.5	411	SOUT[128]	-513.0	572.5
312	SOUT[29]	4833.0	572.5	362	SOUT[79]	2133.0	572.5	412	SOUT[129]	-567.0	572.5
313	SOUT[30]	4779.0	572.5	363	SOUT[80]	2079.0	572.5	413	SOUT[130]	-621.0	572.5
314	SOUT[31]	4725.0	572.5	364	SOUT[81]	2025.0	572.5	414	SOUT[131]	-675.0	572.5
315	SOUT[32]	4671.0	572.5	365	SOUT[82]	1971.0	572.5	415	SOUT[132]	-729.0	572.5
316	SOUT[33]	4617.0	572.5	366	SOUT[83]	1917.0	572.5	416	SOUT[133]	-783.0	572.5
317	SOUT[34]	4563.0	572.5	367	SOUT[84]	1863.0	572.5	417	SOUT[134]	-837.0	572.5
318	SOUT[35]	4509.0	572.5	368	SOUT[85]	1809.0	572.5	418	SOUT[135]	-891.0	572.5
319	SOUT[36]	4455.0	572.5	369	SOUT[86]	1755.0	572.5	419	SOUT[136]	-945.0	572.5
320	SOUT[37]	4401.0	572.5	370	SOUT[87]	1701.0	572.5	420	SOUT[137]	-999.0	572.5
321	SOUT[38]	4347.0	572.5	371	SOUT[88]	1647.0	572.5	421	SOUT[138]	-1053.0	572.5
322	SOUT[39]	4293.0	572.5	372	SOUT[89]	1593.0	572.5	422	SOUT[139]	-1107.0	572.5
323	SOUT[40]	4239.0	572.5	373	SOUT[90]	1539.0	572.5	423	SOUT[140]	-1161.0	572.5
324	SOUT[41]	4185.0	572.5	374	SOUT[91]	1485.0	572.5	424	SOUT[141]	-1215.0	572.5
325	SOUT[42]	4131.0	572.5	375	SOUT[92]	1431.0	572.5	425	SOUT[142]	-1269.0	572.5
326	SOUT[43]	4077.0	572.5	376	SOUT[93]	1377.0	572.5	426	SOUT[143]	-1323.0	572.5
327	SOUT[44]	4023.0	572.5	377	SOUT[94]	1323.0	572.5	427	SOUT[144]	-1377.0	572.5
328	SOUT[45]	3969.0	572.5	378	SOUT[95]	1269.0	572.5	428	SOUT[145]	-1431.0	572.5
329	SOUT[46]	3915.0	572.5	379	SOUT[96]	1215.0	572.5	429	SOUT[146]	-1485.0	572.5
330	SOUT[47]	3861.0	572.5	380	SOUT[97]	1161.0	572.5	430	SOUT[147]	-1539.0	572.5
331	SOUT[48]	3807.0	572.5	381	SOUT[98]	1107.0	572.5	431	SOUT[148]	-1593.0	572.5
332	SOUT[49]	3753.0	572.5	382	SOUT[99]	1053.0	572.5	432	SOUT[149]	-1647.0	572.5
333	SOUT[50]	3699.0	572.5	383	SOUT[100]	999.0	572.5	433	SOUT[150]	-1701.0	572.5
334	SOUT[51]	3645.0	572.5	384	SOUT[101]	945.0	572.5	434	SOUT[151]	-1755.0	572.5
335	SOUT[52]	3591.0	572.5	385	SOUT[102]	891.0	572.5	435	SOUT[152]	-1809.0	572.5
336	SOUT[53]	3537.0	572.5	386	SOUT[103]	837.0	572.5	436	SOUT[153]	-1863.0	572.5
337	SOUT[54]	3483.0	572.5	387	SOUT[104]	783.0	572.5	437	SOUT[154]	-1917.0	572.5
338	SOUT[55]	3429.0	572.5	388	SOUT[105]	729.0	572.5	438	SOUT[155]	-1971.0	572.5
339	SOUT[56]	3375.0	572.5	389	SOUT[106]	675.0	572.5	439	SOUT[156]	-2025.0	572.5
340	SOUT[57]	3321.0	572.5	390	SOUT[107]	621.0	572.5	440	SOUT[157]	-2079.0	572.5
341	SOUT[58]	3267.0	572.5	391	SOUT[108]	567.0	572.5	441	SOUT[158]	-2133.0	572.5
342	SOUT[59]	3213.0	572.5	392	SOUT[109]	513.0	572.5	442	SOUT[159]	-2187.0	572.5
343	SOUT[60]	3159.0	572.5	393	SOUT[110]	459.0	572.5	443	SOUT[160]	-2241.0	572.5
344	SOUT[61]	3105.0	572.5	394	SOUT[111]	405.0	572.5	444	SOUT[161]	-2295.0	572.5
345	SOUT[62]	3051.0	572.5	395	SOUT[112]	351.0	572.5	445	SOUT[162]	-2349.0	572.5
346	SOUT[63]	2997.0	572.5	396	SOUT[113]	297.0	572.5	446	SOUT[163]	-2403.0	572.5
347	SOUT[64]	2943.0	572.5	397	SOUT[114]	243.0	572.5	447	SOUT[164]	-2457.0	572.5
348	SOUT[65]	2889.0	572.5	398	SOUT[115]	189.0	572.5	448	SOUT[165]	-2511.0	572.5
349	SOUT[66]	2835.0	572.5	399	SOUT[116]	135.0	572.5	449	SOUT[166]	-2565.0	572.5
350	SOUT[67]	2781.0	572.5	400	SOUT[117]	81.0	572.5	450	SOUT[167]	-2619.0	572.5

Table 5. Pad Center Coordinates 4 [Unit : μm]

NO	NAME	X	Y	NO	NAME	X	Y	NO	NAME	X	Y
451	SOUT[168]	-2673.0	572.5	501	SOUT[218]	-5373.0	572.5	551	DUMMY	-7697.5	-296.0
452	SOUT[169]	-2727.0	572.5	502	SOUT[219]	-5427.0	572.5				
453	SOUT[170]	-2781.0	572.5	503	SOUT[220]	-5481.0	572.5				
454	SOUT[171]	-2835.0	572.5	504	SOUT[221]	-5535.0	572.5				
455	SOUT[172]	-2889.0	572.5	505	SOUT[222]	-5589.0	572.5				
456	SOUT[173]	-2943.0	572.5	506	SOUT[223]	-5643.0	572.5				
457	SOUT[174]	-2997.0	572.5	507	SOUT[224]	-5697.0	572.5				
458	SOUT[175]	-3051.0	572.5	508	SOUT[225]	-5751.0	572.5				
459	SOUT[176]	-3105.0	572.5	509	SOUT[226]	-5805.0	572.5				
460	SOUT[177]	-3159.0	572.5	510	SOUT[227]	-5859.0	572.5				
461	SOUT[178]	-3213.0	572.5	511	SOUT[228]	-5913.0	572.5				
462	SOUT[179]	-3267.0	572.5	512	SOUT[229]	-5967.0	572.5				
463	SOUT[180]	-3321.0	572.5	513	SOUT[230]	-6021.0	572.5				
464	SOUT[181]	-3375.0	572.5	514	SOUT[231]	-6075.0	572.5				
465	SOUT[182]	-3429.0	572.5	515	SOUT[232]	-6129.0	572.5				
466	SOUT[183]	-3483.0	572.5	516	SOUT[233]	-6183.0	572.5				
467	SOUT[184]	-3537.0	572.5	517	SOUT[234]	-6237.0	572.5				
468	SOUT[185]	-3591.0	572.5	518	SOUT[235]	-6291.0	572.5				
469	SOUT[186]	-3645.0	572.5	519	SOUT[236]	-6345.0	572.5				
470	SOUT[187]	-3699.0	572.5	520	SOUT[237]	-6399.0	572.5				
471	SOUT[188]	-3753.0	572.5	521	SOUT[238]	-6453.0	572.5				
472	SOUT[189]	-3807.0	572.5	522	SOUT[239]	-6507.0	572.5				
473	SOUT[190]	-3861.0	572.5	523	SOUT[240]	-6561.0	572.5				
474	SOUT[191]	-3915.0	572.5	524	SOUT_DUM240	-6615.0	572.5				
475	SOUT[192]	-3969.0	572.5	525	DUMMY	-6669.0	572.5				
476	SOUT[193]	-4023.0	572.5	526	DUMMY	-6723.0	572.5				
477	SOUT[194]	-4077.0	572.5	527	DUMMY	-6777.0	572.5				
478	SOUT[195]	-4131.0	572.5	528	DUMMY	-6831.0	572.5				
479	SOUT[196]	-4185.0	572.5	529	DUMMY	-6885.0	572.5				
480	SOUT[197]	-4239.0	572.5	530	DUMMY	-6939.0	572.5				
481	SOUT[198]	-4293.0	572.5	531	XCK	-6993.0	572.5				
482	SOUT[199]	-4347.0	572.5	532	XCK	-7047.0	572.5				
483	SOUT[200]	-4401.0	572.5	533	CK	-7101.0	572.5				
484	SOUT[201]	-4455.0	572.5	534	CK	-7155.0	572.5				
485	SOUT[202]	-4509.0	572.5	535	DUMMY	-7209.0	572.5				
486	SOUT[203]	-4563.0	572.5	536	DUMMY	-7263.0	572.5				
487	SOUT[204]	-4617.0	572.5	537	SIN	-7317.0	572.5				
488	SOUT[205]	-4671.0	572.5	538	SIN	-7371.0	572.5				
489	SOUT[206]	-4725.0	572.5	539	DUMMY	-7425.0	572.5				
490	SOUT[207]	-4779.0	572.5	540	DUMMY	-7697.5	298.0				
491	SOUT[208]	-4833.0	572.5	541	DUMMY	-7697.5	244.0				
492	SOUT[209]	-4887.0	572.5	542	DUMMY	-7697.5	190.0				
493	SOUT[210]	-4941.0	572.5	543	DUMMY	-7697.5	136.0				
494	SOUT[211]	-4995.0	572.5	544	DUMMY	-7697.5	82.0				
495	SOUT[212]	-5049.0	572.5	545	DUMMY	-7697.5	28.0				
496	SOUT[213]	-5103.0	572.5	546	DUMMY	-7697.5	-26.0				
497	SOUT[214]	-5157.0	572.5	547	DUMMY	-7697.5	-80.0				
498	SOUT[215]	-5211.0	572.5	548	DUMMY	-7697.5	-134.0				
499	SOUT[216]	-5265.0	572.5	549	DUMMY	-7697.5	-188.0				
500	SOUT[217]	-5319.0	572.5	550	DUMMY	-7697.5	-242.0				

5. I/O Signal Description

5.1. Power Supply Signals

Table 6. Power Supply Signal Description 1

Symbol	Type	Description
VDD	Power	Power supply for internal logic and internal RAM. Internally, voltage regulator output is connected to this pad. Connect a capacitor for stabilization. Don't apply any external power to this pad.
MVDD	Power	Internal power for RAM. Connect this pad to VDD externally.
RVDD	Power	Regulated logic power voltage (1.5V)
VDD3	Power	I/O power supply. (1.65V ~ 3.3V)
VCI	Power	Power supply for analog circuits. (VCI : 2.5 ~ 3.3V) An internal reference power supply for VCI1 amp.
VCI_MDDI	Power	Analog power supply (VCI_MDDI : 2.5 ~ 3.3V)
VSS VSSA VSSC	Ground	System ground (0V).
VSS_MDDI	Power	System ground level for I/O
VGS	I	A reference level for the grayscale voltage generation circuit. Connect this pad to an external resistor when a source driver is used to adjust grayscale levels for each panel.
VCI1	I/O	A reference voltage for 1st booster.
VCIRIN	I	A reference voltage input pad for power block when using an external VCIR generation mode.
VLIN1 / VLOUT1	I/O	Input pad for applying VLOUT1 voltage level / 1st booster output pad. Recommend to connect VLIN1 to VLOUT1.
VLIN2 / VLOUT2	I/O	Input pad for applying VLOUT2 voltage level / 2nd booster output pad. Recommend to connect VLIN2 to VLOUT2.

Table 7. Power Supply Signal Description 2

Symbol	Type	Description
VLIN3 / VLOUT3	I/O	Input pad for applying VLOUT3 voltage level / 3rd booster output pad. Recommend to connect VLIN3 to VLOUT3.
C11P,C11M C12P,C12M	I/O	External capacitor connection pads used for the 1'st booster circuit.
C21P,C21M	I/O	External capacitor connection pads used for the 2nd booster circuit.
C31P,C31M C32P,C32M	I/O	External capacitor connection pads used for the 3rd booster circuit.
VREG1OUT	I/O	A reference level for the grayscale voltage with the amplitude between VLOUT1 and GND.
VGH	O	The positive voltage used in the gate driver.
VGL	O	The negative voltage used in the gate driver.
VINT	O	A voltage for initializing an OLED panel.
VSP	O	Test signal, this pad must be open.
ELVDD	I	Test signal, this pad must be fixed to VSS level.
MTPG	I	A voltage for the MTP programming (Initialization, Erasing, and Programming). If not use, this pad must be open.
MTPD	I	A voltage for the MTP programming (Initialization, Erasing, and Programming). If not use, this pad must be open.
Vtest	I	Test signal, this pad must be fixed to VSS level.

5.2. System / RGB Interface Signals

Figure 4. System / RGB Interface Signal Description 1

Symbol	Type	Description		
S_PB	I	Selects the CPU interface mode "Low" = Parallel Interface, "High" = Serial Interface		
MDDI_EN	I	Selects the MDDI interface "Low" = MDDI Disable, "High" = MDDI Enable		
ID_MIB	I	Selects the CPU type "Low" = Intel 80x-system, "High" = Motorola 68x-system If S-PB = "High", the pad is used as ID setting bit for a device code.		
CSB	I	Chip select signal input signal. Low: S6E63D6 is selected and can be accessed High: S6E63D6 is not selected and cannot be accessed		
RS	I	Register select signal. Low: Index/status, High: Instruction parameter, GRAM data Must be fixed at VDD3 level when not used.		
RW_WRB/SCL	I	Signal function	CPU type	Signal description
		RW	68-system	Read/Write operation selection signal. Low: Write, High: Read
		WRB	80-system	Write strobe signal. (Input signal) Data is fetched at the rising edge.
		SCL	Serial Peripheral Interface (SPI)	The synchronous clock signal. (Input signal)
E_RDB	I	Signal function	CPU type	Signal description
		E	68-system	Read/Write operation enable signal.
		RDB	80-system	Read strobe signal. (Input signal) Read out data at the low level.
When SPI mode is selected, fix this pad at VDD3 level.				
SDI	I	For a serial peripheral interface (SPI), input data is fetched at the rising edge of the SCL signal. Fix SDI pad at VSS level if the pad is not used.		
SDO	O	For a serial peripheral interface (SPI), serves as the serial data output signal (SDO). Successive bits are output at the falling edge of the SCL signal.		
RESETB	I	Reset signal Initializes the IC when low. Should be reset after power-on.		

Table 8. System / RGB Interface Signal Description 2

Symbol	Type	Description																				
DB17-DB0	I/O	<p>Bi-directional data bus. When CPU I/F,</p> <p style="padding-left: 40px;">18-bit interface : DB 17-0 16-bit interface : DB 17-10, DB 8-1 9-bit interface : DB 8-0 8-bit interface : DB 8-1</p> <p>When RGB I/F,</p> <p style="padding-left: 40px;">18-bit interface : DB 17-0 16-bit interface : DB 17-10, DB 8-1 6-bit interface : DB 8-3</p> <p>Fix unused pad to the VSS level.</p>																				
ENABLE	I	<p>Data enable signal pad for RGB interface. EPL="0": Only in case of ENABLE="Low", the IC can be access via RGB interface. EPL="1": Only in case of ENABLE="High", the IC can be access via RGB interface</p>																				
		<table border="1" style="width: 100%; text-align: center;"> <thead> <tr> <th>EPL</th> <th>ENABLE</th> <th>GRAM Write</th> <th>GRAM Address</th> </tr> </thead> <tbody> <tr> <td>0</td> <td>0</td> <td>Valid</td> <td>Updated</td> </tr> <tr> <td>0</td> <td>1</td> <td>Invalid</td> <td>Held</td> </tr> <tr> <td>1</td> <td>0</td> <td>Invalid</td> <td>Held</td> </tr> <tr> <td>1</td> <td>1</td> <td>Valid</td> <td>Updated</td> </tr> </tbody> </table>	EPL	ENABLE	GRAM Write	GRAM Address	0	0	Valid	Updated	0	1	Invalid	Held	1	0	Invalid	Held	1	1	Valid	Updated
		EPL	ENABLE	GRAM Write	GRAM Address																	
		0	0	Valid	Updated																	
		0	1	Invalid	Held																	
		1	0	Invalid	Held																	
1	1	Valid	Updated																			
Fix ENABLE pad at VSS level if the pad is not used.																						
VSYNC	I	<p>Frame-synchronizing signal. VSPL= "0": Low active, VSPL="1": High active Fix this pad at VSS level if the pad is not used.</p>																				
HSYNC	I	<p>Line-synchronizing signal. HSPL="0": Low active, HSPL="1": High active Fix this pad at VSS level if the pad is not used.</p>																				
DOTCLK	I	<p>Input signal for clock signal of external interface: dot clock. DPL="0": Display data is fetched at DOTCLK's rising edge DPL="1": Display data is fetched at DOTCLK's falling edge Fix this pad at VSS level if the pad is not used.</p>																				

5.3. MDDI Signals

Table 9. MDDI Signal Description

Symbol	Type	Description
MDP	I/O	Positive MDDI data input/output. If MDDI is not used, this pad should be floating.
MDN	I/O	Negative MDDI data input/output. If MDDI is not used, this pad should be floating.
MSP	I	Positive MDDI strobe input. If MDDI is not used, this pad should be floating.
MSN	I	Negative MDDI strobe input. If MDDI is not used, this pad should be floating.
GPIO[9:0] (DB[17:8])	I/O	General purpose input/output If GPIO is not used in MDDI mode, these pads should be fixed at VSS level.
S_CSB (DB[7])	O	Chip select for Sub Panel Driver IC Low: Sub Panel Driver IC is selected and can be accessed. High: Sub Panel Driver IC is not selected and can not be accessed. If sub panel is not used in MDDI mode, this pad should be floating
S_RS (DB[6])	O	Register select for Sub Panel Driver IC Low : Index/status, High : Control If sub panel is not used in MDDI mode, this pad should be floating
S_WRB (DB[5])	O	Write Strobe signal for Sub Panel Driver IC If sub panel is not used in MDDI mode, this pad should be floating
S_DB[8:0] (DB[4:0], TE, TEST_OUT[2:0])	O	For Sub Panel, these pads can be used to transfer DB[8:0] data to Sub Panel Driver IC. If sub panel is not used in MDDI mode, these pads should be floating.
HSYNC VSYNC ENABLE DOTCLK	I	In MDDI mode, Fixed at VSS level.
RW_WRB E_RDB RS	I	In MDDI mode, Fixed at VDD3 level.
CSB	I	In MDDI mode, Fixed at VDD3 level.

5.4. Display Signals

Table 10. Display Signal Description

Symbol	Type	Description
SOUT[1:240]	O	Source driver output signals. The direction of them is determined by the value of SS register.
SIN	O	Start pulse of vertical line shift.
CK, XCK	O	Clock for gate driver shift.
R_sw, G_sw, B_sw	O	LTPS signals
EL_ON	O	The external ELVDD regulator enable signal

5.5. Miscellaneous Signals

Table 11. Miscellaneous Signal Description

Symbol	Type	Description
DUMMYR[3:1] DUMMYL[3:1]	-	Contact resistance measurement pads. In normal operation, leave these pads open
DUMMY	-	Dummy pads don't care. Leave these pads open.
V0/V63	O	Gamma voltage monitoring pad.
VDD3DUM	O	This pad is connected to VDD3 line internally. Use for to connect neighbor-setting pads.
VSSDUM	O	This pad is connected to VSS line internally. Use for to connect neighbor-setting pads.
FUSE_EN	I	Don't use this pad. IC maker's test pad. This pad must be tied to VDD3.
RTEST	I	Don't use this pad. IC maker's test pad. This pad must be tied to VSS.
EN_EXCLK	I	Don't use this pad. IC maker's test pad. Fix this pad at VSS level if the pad is not used.
EXCLK	I	Don't use this pad. IC maker's test pad. Fix this pad at VSS level if the pad is not used.
TEST_MODE[1:0]]	I	Don't use these pads. IC maker's test pads. Fix these pads at VSS level if the pads are not used.
TEST_IN[6:0]	I	Don't use these pads. IC maker's test pads. Fix these pads at VSS level if the pads are not used.
TE	O	Tearing effect output signal. In normal operation, leave this pad open.
TEST_OUT[2:0]	O	Output pads used only for test purpose at vendor-side. In normal operation, leave these pads open.

Note.

1. Panel ITO must not cross all dummy pads.

6. Function Description

6.1. System Interface

The S6E63D6 has ten high-speed system interfaces: an 80-system 18-/16-/9-/8-bit bus, a 68-system 18-/16-/9-/8-bit and two type serial interface (SPI: Serial Peripheral Interface).

The S6E63D6 has three 18-bit registers: an index register (IR), a write data register (WDR), and a read data register (RDR). The IR stores index information for control register and GRAM. The WDR temporarily stores data to be written into control register and GRAM. The RDR temporarily stores data read from GRAM. Data written into the GRAM from CPU is initially written to the WDR and then written to the GRAM automatically. Data is read through the RDR when reading from the GRAM, and the first read data is invalid and the second and the following data are valid.

Execution time for instruction, except oscillation start, is 0-clock cycle so that instructions can be written in succession.

Table 12. Register Selection (18-/16-/9-/8- parallel interface)

SYSTEM	RW_WRB	E_RDB	RS	Operations
68	0	1	0	Write index to IR
	1	1	0	Read internal status
	0	1	1	Write to control register and GRAM through WDR
	1	1	1	Read from GRAM through RDR
80	0	1	0	Write index to IR
	1	0	0	Read internal status
	0	1	1	Write to control register and GRAM through WDR
	1	0	1	Read from GRAM through RDR

Table 13. CSB Signal (GRAM update control)

CSB	Operation
0	Data is written to GRAM, GRAM address is updated
1	Data is not written to GRAM, GRAM address is not updated

Table 14. Register Selection (Serial peripheral interface)

R/W bit	RS bit	Operation
0	0	Write index to IR
1	0	Read internal status
0	1	Write data to control register and GRAM through WDR
1	1	Read data from GRAM through RDR

6.2. High Speed Serial Interface (MDDI)

This interface will be introduced, see the section “Description of MDDI Interface”

6.3. Sub Panel Control

Sub panel control block will be introduced, see the section “Description of Sub Panel Control”

6.4. External Interface (RGB I/F)

The S6E63D6 incorporates RGB interface as external interface for motion picture display.

When the RGB interface is selected, the synchronization signals (VSYNC, HSYNC, and DOTCLK) are available for display. The RGB data for display (DB17-0) are written according to enable signal (ENABLE) in synchronization with VSYNC, HSYNC, and DOTCLK signal. This allows flicker-free updating of the screen. See the section on the external display interface.

6.5. Address Counter (AC)

The address counter (AC) assigns address to GRAM. When an address-set-instruction is written to the IR, the address information is sent from IR to AC. After writing to the GRAM, the address value of AC is automatically increased/ decreased by 1 according to ID1-0 bit of control register. After reading data from GRAM, the AC is updated automatically.

6.6. Graphics RAM (GRAM)

The graphics RAM (GRAM) has 18-bits/pixel and stores the bit-pattern data for 240-RGB x 320-dot display.

6.7. Timing Generator

The panel interface controller generates timing signals for LTPS drive. Also it generates control signals for the operation of internal circuits such as source driver and GRAM. The GRAM read operations done by this timing generator and GRAM write operations done through system interface are performed independently to avoid the interference between them.

6.8. Grayscale Voltage Generator

The grayscale voltage circuit generates OLED driving voltage that corresponds to the grayscale levels as specified in the grayscale gamma-adjusting registers. 262,144 possible colors can be displayed at the same time by this LSI.

Gamma is set for R,G, and B individually.

6.9. Oscillation Circuit (OSC)

The S6E63D6 can provide R-C oscillation simply through the internal oscillation-resistor. The appropriate oscillation frequency for operating voltage, display size, and frame frequency can be obtained by adjusting the internal register. Since R-C oscillation stops during the standby mode, current consumption can be reduced. For details, see the Oscillation Circuit section.

6.10. Source Driver Circuit

The source driving circuit of S6E63D6 consists of a 240 source drivers (SOUT[1] to SOUT[240]). Image data is latched when 240-pixel data has arrived. The latched data then enables the source drivers to generate drive waveform outputs.

The SS register can change the shift direction of 240 source driver output data for the device-mount configuration.

6.11. LTPS Panel Interface Circuit

LTPS panel interface circuit does level-shift operation and outputs to control LTPS panel.

6.12. GRAM Address Map

The image data stored in GRAM corresponds to pixel data on display as shown below:

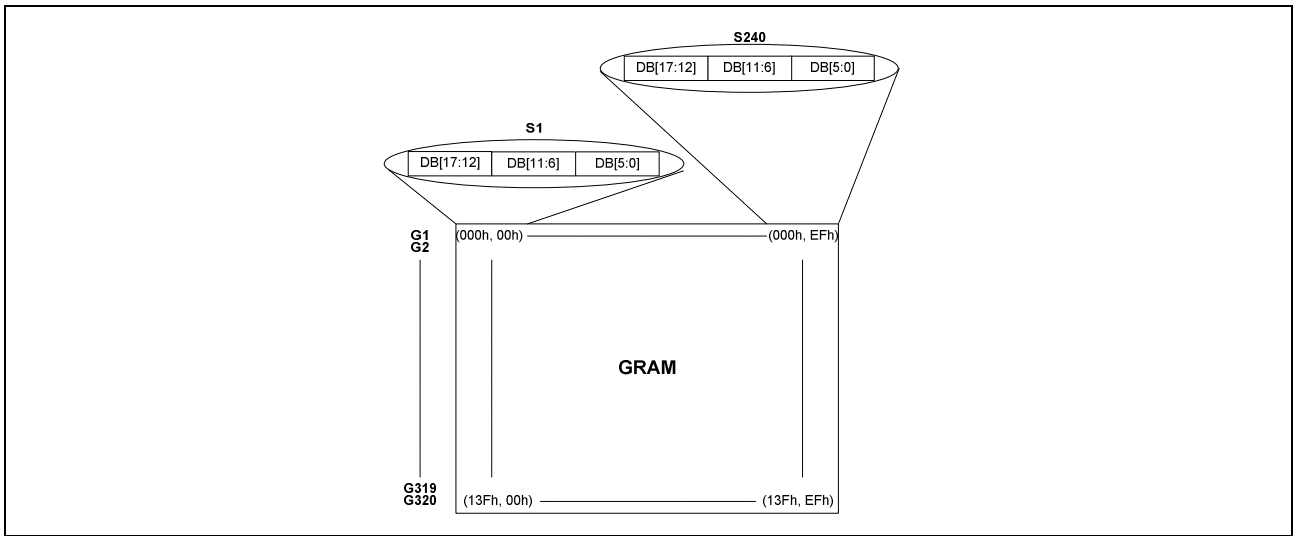

Figure 5. GRAM Address (SS="0")

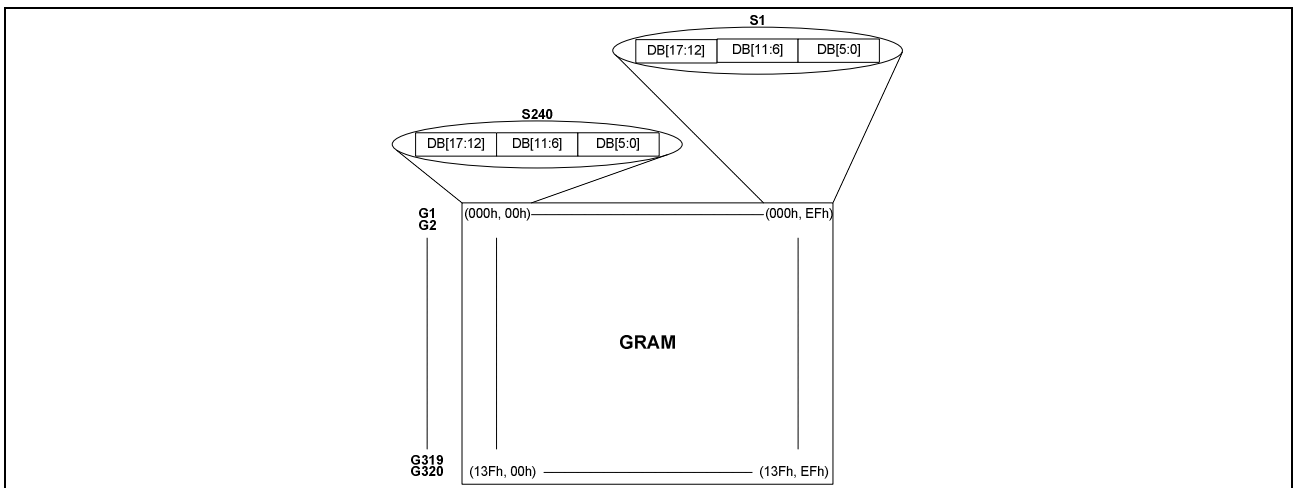

Figure 6. GRAM Address (SS="1")

7. Instructions

The S6E63D6 uses the 18-bit bus architecture. Before the internal operation of the S6E63D6 starts, control information is stored temporarily in the registers described below to allow high-speed interfacing with a high-performance microcomputer. The internal operation of the S6E63D6 is determined by signals sent from the microcomputer. These signals, which include the register selection signal (RS), the read/write signal (R/W), and the data bus signals (DB17 to DB0), make up the S6E63D6 instructions.

There are seven categories of instructions that:

- Specify the index
- Control the display
- Control power management
- Set internal GRAM addresses
- Transfer data to and from the internal GRAM
- Set grayscale level for the internal grayscale palette table
- Interface with the LTPS driver and power supply IC

Normally, instructions that write data are used the most. However, an auto-update of internal GRAM addresses after each data write can lighten the microcomputer program load. As instructions are executed in 0 cycles, they can be written in succession.

The 16-bit instruction assignment differs from interface-setup (18-/16-/9-/8-/SPI), so instructions should be fetched according to the data format.

7.1. Instruction Table

Table 15. Instruction Table 1

Index	Reg. No	R/W	RS		IB 15	IB 14	IB 13	IB 12	IB 11	IB 10	IB 9	IB 8	IB 7	IB 6	IB 5	IB 4	IB 3	IB 2	IB 1	IB 0
I/F Control	IR	W	0	Set index register value	X	X	X	X	X	X	X	X	ID7	ID6	ID5	ID4	ID3	ID2	ID1	ID0
	SR	R	0	Status Read	X	X	X	X	X	X	X	L8	L7	L6	L5	L4	L3	L2	L1	L0
	R0h	W	0	No Operation	No operation															
Display Control	R01h	W	1	Display Duty control	FP3	FP2	FP1	FP0	BP3	BP2	BP1	BP0	X	X	NL5	NL4	NL3	NL2	NL1	NL0
	R02h	W	1	RGB Interface Control	X	X	X	X	X	X	X	RM	DM	X	RIM1	RIM0	VSPL	HSPL	EPL	DPL
	R03h	W	1	Entry Mode	CLS	MDT1	MDT0	BGR	X	X	X	SS	X	X	I/D1	I/D0	X	X	X	AM
	R04h	W	1	Clock Control	X	X	X	X	X	X	X	X	X	X	DCR1	DCR0	X	X	X	X
	R05h	W	1	Display Control1	X	X	X	X	X	X	X	X	X	X	X	X	X	X	X	DISP_ON
	R06h	W	1	Display Control2	X	X	X	X	X	X	X	X	X	X	X	CL	X	X	TEMON	REV
	R07h	W	1	Panel IF Control1	X	X	X	CLWE A4	CLWE A3	CLWE A2	CLWE A1	CLWE A0	X	X	X	X	X	X	X	X
	R08h	W	1	Panel IF Control1	X	X	X	CLWE B4	CLWE B3	CLWE B2	CLWE B1	CLWE B0	X	X	X	CLWE C4	CLWE C3	CLWE C2	CLWE C1	CLWE C0
	R09h	W	1	Panel IF Control2	X	X	X	X	X	X	X	X	X	X	SHE2	SHE1	SHE0	X	CLTE 2	CLTE 1
Device Read	R0Fh	R	1	Device code read Read 63D6h	0	1	1	0	0	0	1	1	1	1	0	1	0	1	1	0
Power Control	R10h	W	1	Stand By	X	X	X	X	X	X	X	X	X	X	X	X	X	NAP	X	STB
	R12h	W	1	Power Gen1	X	X	X	X	X	X	X	X	X	X	X	X	VC3	VC2	VC1	VC0
	R13h	W	1	Power Gen2	X	X	VINT3	VINT2	VINT1	VINT0	X	X	X	X	X	X	X	X	X	X
	RF8h	W	1	Power Gen3	X	X	X	X	X	X	X	X	X	X	X	VGH4	VGH3	VGH2	VGH1	VGH0
	RF9h	W	1	Power Gen4	X	X	X	X	X	X	X	X	X	X	X	VGL4	VGL3	VGL2	VGL1	VGL0
	R14h	W	1	Power Booster Control	X	DC22	DC21	DC0		DC12	DC11	DC10	X	X	X	X	X	X	BT1	BT0
	R18h	W	1	Oscillator Control	X	X	X	X	X	X	X	X	X	X	RADJ 5	RADJ 4	RADJ 3	RADJ 2	RADJ 1	RADJ 0
	R1Ah	W	1	Source Driver Control	X	X	X	X	X	X	X	X	X	X	GAMMA_T EST	SDUM_ON	X	SAP2	SAP1	SAP0
GRAM Access	R20h	W	1	GRAM address set AD16-0: Set GRAM	X	X	X	X	X	X	X	X	AD7	AD6	AD5	AD4	AD3	AD2	AD1	AD0
	R21h	W	1		X	X	X	X	X	X	X	AD16	AD15	AD14	AD13	AD12	AD11	AD10	AD9	AD8

Table 16. Instruction Table 2

Index	Reg. No	R/W	RS		IB 15	IB 14	IB 13	IB 12	IB 11	IB 10	IB 9	IB 8	IB 7	IB 6	IB 5	IB 4	IB 3	IB 2	IB 1	IB 0	
GRAM Access	R22h	W	1	GRAM Write	WD17-0 : Pad assignment varies according to the interface method																
		R	1	GRAM Read	RD17-0 : Pad assignment varies according to the interface method																
I/F Control	R23h	W	0	I/F Select	Select 18/16-Bit Data Bus Interface																
	R24h	W	0		Select 9/8-Bit Data Bus Interface																
Position Control	R30h	W	1	Vertical Scroll Control 1	X	X	X	X	X	X	X	X	SSA8	SSA7	SSA6	SSA5	SSA4	SSA3	SSA2	SSA1	SSA0
	R31h	W	1		X	X	X	X	X	X	X	X	SEA8	SEA7	SEA6	SEA5	SEA4	SEA3	SEA2	SEA1	SEA0
	R32h	W	1	Vertical Scroll Control 2	X	X	X	X	X	X	X	X	SST8	SST7	SST6	SST5	SST4	SST3	SST2	SST1	SST0
	R33h	W	1	Partial Screen Driving Position	X	X	X	X	X	X	X	X	SS18	SS17	SS16	SS15	SS14	SS13	SS12	SS11	SS10
	R34h	W	1		X	X	X	X	X	X	X	X	SE18	SE17	SE16	SE15	SE14	SE13	SE12	SE11	SE10
	R35h	W	1	Vertical RAM Address Position	X	X	X	X	X	X	X	X	VSA8	VSA7	VSA6	VSA5	VSA4	VSA3	VSA2	VSA1	VSA0
	R36h	W	1		X	X	X	X	X	X	X	X	VEA8	VEA7	VEA6	VEA5	VEA4	VEA3	VEA2	VEA1	VEA0
R37h	W	1	Horizontal RAM Address Position	HSA7	HSA6	HSA5	HSA4	HSA3	HSA2	HSA1	HSA0	HEA7	HEA6	HEA5	HEA4	HEA3	HEA2	HEA1	HEA0		
MDDI I/F	38h	W	1	Client initiated wake-up	X	X	X	X	X	X	X	X	X	X	X	X	X	X	X	X	VWAKE_EN
	39h	W	1	MDDI Link wake-up start position	WKL8	WKL7	WKL6	WKL5	WKL4	WKL3	WKL2	WKL1	WKL0	X	WKF3	WKF2	WKF1	WKF0	X	X	
	3Ah	W	1	Sub panel control	X	X	X	X	X	X	X	X	X	SUB_SEL7	SUB_SEL6	SUB_SEL5	SUB_SEL4	SUB_SEL3	SUB_SEL2	SUB_SEL1	SUB_SEL0
	3Bh	W	1		X	X	X	X	X	X	X	X	X	SUB_WR7	SUB_WR6	SUB_WR5	SUB_WR4	SUB_WR3	SUB_WR2	SUB_WR1	SUB_WR0
3Ch	W	1	X		X	X	X	X	X	X	X	X	FCV_EN	X	X	X	MPU_MODE	STN_EN	SUB_I M1	SUB_I M0	

Table 17. Instruction Table 3

Index	Reg. No	R/W	RS		IB 15	IB 14	IB 13	IB 12	IB 11	IB 10	IB 9	IB 8	IB 7	IB 6	IB 5	IB 4	IB 3	IB 2	IB 1	IB 0
MTP Control	R60h	W	1	Test Key	X	X	X	X	X	X	X	X	0	0	0	0	1	1	1	1
	R61h	W	1	MTP Control	X	X	X	X	X	X	X	MTP_WRB	X	X	X	MTP_SEL	X	X	X	MTP_ERB
	R62h	W	1	MTP Register Setting R	X	X	X	X	R21_B T2	R21_B T1	R21_B T0	X	X	X	X	X	R63_B T3	R63_B T2	R63_B T1	R63_B T0
	R63h	W	1	MTP Register Setting G	X	X	X	X	G21_BT2	G21_BT1	G21_BT0	X	X	X	X	X	G63_BT3	G63_BT2	G63_BT1	G63_BT0
	R64h	W	1	MTP Register Setting B	X	X	X	X	B21_B T2	B21_B T1	B21_B T0	X	X	X	X	X	B63_B T3	B63_B T2	B63_B T1	B63_B T0
	R65h	W	1	MTP Register Setting Offset	X	X	X	X	X	X	X	X	X	X	X	X	X	E_OS T2	E_OS T1	E_OS T0
GPIO Control	R66h	W	1	GPIO value	X	X	X	X	X	X	GPIO9	GPIO8	GPIO7	GPIO6	GPIO5	GPIO4	GPIO3	GPIO2	GPIO1	GPIO0
	R67h	W	1	GPIO in/output control	X	X	X	X	X	X	GPIO_CON9	GPIO_CON8	GPIO_CON7	GPIO_CON6	GPIO_CON5	GPIO_CON4	GPIO_CON3	GPIO_CON2	GPIO_CON1	GPIO_CON0
	R68h	W	1	GPIO Clear	X	X	X	X	X	X	GPCL R9	GPCL R8	GPCL R7	GPCL R6	GPCL R5	GPCL R4	GPCL R3	GPCL R2	GPCL R1	GPCL R0
	R69h	W	1	GPIO interrupt Enable	X	X	X	X	X	X	GPIO_EN9	GPIO_EN8	GPIO_EN7	GPIO_EN6	GPIO_EN5	GPIO_EN4	GPIO_EN3	GPIO_EN2	GPIO_EN1	GPIO_EN0
	R6Ah	W	1	GPIO polarity selection	X	X	X	X	X	X	GPPO L9	GPPO L8	GPPO L7	GPPO L6	GPPO L5	GPPO L4	GPPO L3	GPPO L2	GPPO L1	GPPO L0
Gamma Control	R70h	W	1	Gamma Top Bottom Control R	X	X	CR56	CR55	CR54	CR53	CR52	CR51	CR50	X	X	X	CR03	CR02	CR01	CR00
	R71h	W	1	Gamma Top Bottom Control G	X	X	CG56	CG55	CG54	CG53	CG52	CG51	CG50	X	X	X	CG03	CG02	CG01	CG00
	R72h	W	1	Gamma Top Bottom Control B	X	X	CB56	CB55	CB54	CB53	CB52	CB51	CB50	X	X	X	CB03	CB02	CB01	CB00
	R73h	W	1	Gamma Control R 1,2	X	X	CR15	CR14	CR13	CR12	CR11	CR10	X	X	CR25	CR24	CR23	CR22	CR21	CR20
	R74h	W	1	Gamma Control R 3,4	X	X	CR35	CR34	CR33	CR32	CR31	CR30	X	X	CR45	CR44	CR43	CR42	CR41	CR40
	R75h	W	1	Gamma Control G 1,2	X	X	CG15	CG14	CG13	CG12	CG11	CG10	X	X	CG25	CG24	CG23	CG22	CG21	CG20
	R76h	W	1	Gamma Control G 3,4	X	X	CG35	CG34	CG33	CG32	CG31	CG30	X	X	CG45	CG44	CG43	CG42	CG41	CG40
	R77h	W	1	Gamma Control B 1,2	X	X	CB15	CB14	CB13	CB12	CB11	CB10	X	X	CB25	CB24	CB23	CB22	CB21	CB20
	R78h	W	1	Gamma Control B 3,4	X	X	CB35	CB34	CB33	CB32	CB31	CB30	X	X	CB45	CB44	CB43	CB42	CB41	CB40
EL Control	RF4h	W	1	EL control	X	X	X	X	X	X	X	X	X	X	EL_TEST	EL_ON	X	X	X	X

7.2. Instruction Descriptions

7.2.1. Index

The index instruction specifies indexes. It sets the register number in the range of 00000000b to 11110100b in binary form. However, do not access index registers and instruction bits that are not allocated in this document.

R/W	RS	IB15	IB14	IB13	IB12	IB11	IB10	IB9	IB8	IB7	IB6	IB5	IB4	IB3	IB2	IB1	IB0
W	0	X	X	X	X	X	X	X	X	ID7	ID6	ID5	ID4	ID3	ID2	ID1	ID0

7.2.2. Status Read

The status read instruction reads out the internal status of the IC.

R/W	RS	IB15	IB14	IB13	IB12	IB11	IB10	IB9	IB8	IB7	IB6	IB5	IB4	IB3	IB2	IB1	IB0
R	0	0	0	0	0	0	0	0	L8	L7	L6	L5	L4	L3	L2	L1	L0

L8–0: Indicate the position of horizontal line currently being driven.

7.2.3. No Operation (R00h)

R/W	RS	IB15	IB14	IB13	IB12	IB11	IB10	IB9	IB8	IB7	IB6	IB5	IB4	IB3	IB2	IB1	IB0
W	0	No Operation															

This command does not have any effect on the display module. However it can be used to terminate Memory Write and Read in 22h command.

7.2.4. Display Duty Control (R01h)

R/W	RS	IB15	IB14	IB13	IB12	IB11	IB10	IB9	IB8	IB7	IB6	IB5	IB4	IB3	IB2	IB1	IB0
W	1	FP3	FP2	FP1	FP0	BP3	BP2	BP1	BP0	X	X	NL5	NL4	NL3	NL2	NL1	NL0

*01h Initial Value = 1000_1000_XX10_1000

7.2.4.1. FP / BP

Set the period of blank area, which is placed at the beginning and the end of a frame. FP[3:0] is for a Front Porch and BP[3:0] is for a Back Porch. When Front Porch and Back Porch are set, the settings should meet the following conditions.

BP+FP ≤20 lines

FP 8 lines

BP 8 lines

When S6E63D6 operates in External Clock Operation mode, the Back Porch (BP) will start on the falling edge of the VSYNC signal and display operation begins just after the Back Porch period. The Front Porch (FP) will start when data of the number of lines specified by the NL has been displayed. During the period between the completion of the Front Porch and the next VSYNC signal, the display will remain blank.

Table 18. Blank Period Control with FP and BP

FP[3:0] (BP[3:0])	Number of Raster Periods In Front (Back) Porch
0000	Setting disable
0001	Setting disable
0010	Setting disable
0011	Setting disable
0100	Setting disable
---	Setting disable
1000	8
---	---
1100	12
1101	Setting disable
1110	Setting disable
1111	Setting disable

7.2.4.2. NL

Specify the number of lines driving OLED drive. The number of lines for the OLED drive can be adjusted for every eight lines. The selected value should be equal to or larger than the size of the panel to be driven.

GRAM address mapping is not affected by the value of the drive duty ratio.

Table 19. NL and Drive Duty

NL[5:0]	Display Size	Drive Line
00_0000 ~ 01_0011	Setting disable	
01_0100	240 X 160	160
01_0101	240 X168	168
01_0110	240X176	176
01_0111	240X184	184
---	---	---
10_0111	240 X 312	312
10_1000	240 X 320	320
10_1001 ~ 11_1111	Setting disable	

Note

1. A back porch period and a front porch period will be inserted as a blank period before and after driving all LTPS lines

7.2.5. RGB Interface Control (R02h)

R/W	RS	IB15	IB14	IB13	IB12	IB11	IB10	IB9	IB8	IB7	IB6	IB5	IB4	IB3	IB2	IB1	IB0
W	1	X	X	X	X	X	X	X	RM	DM	X	RIM1	RIM0	VSPL	HSPL	EPL	DPL

*02h Initial Value = XXXX_XXX0_0X00_0000

7.2.5.1. Internal Clock Mode

All display operation is controlled by signals generated by the internal clock in internal clock mode.

All inputs through the external display interface are invalid. The internal RAM can be accessed only via the system interface.

7.2.5.2. RGB Interface Mode

The display operation is controlled by the frame synchronization clock (VSYNC), raster-row synchronization signal (HSYNC), and dot clock (DOTCLK) in RGB interface mode. These signals should be supplied during display operation in this mode.

The display data is transferred to the internal RAM via DB17-0 for each pixel. Combining the function of the high-speed write mode and the window address enables display of both the motion picture area and the internal RAM area simultaneously. In this method, data is only transferred when the screen is updated, which reduces the amount of data transferred.

The periods of the front (FP), back (BP) porch, and the display are automatically generated in the S6E63D6 by counting the raster-row synchronization signal (HSYNC) based on the frame synchronization signal (VSYNC).

7.2.5.3. RM

Specify the interface for GRAM access as shown below. This register and DM register can be set independently.

7.2.5.4. DM

Specify the display operation mode. The interface can be set based on the bit of DM. In internal clock operation mode the source clock for display operation comes from internal oscillator while in external clock operation mode it comes from RGB interface(DOTCLK, VSYNC, HSYNC).

Table 20. RM, DM, GRAM Access Interface and Display Operation Mode

RM	DM	GRAM Access Interface	Display operation mode
0	0	System interface	Internal clock operation
1	1	RGB interface	External clock operation

Note

1. [RM, DM]= 01, [RM, DM]=10 Setting disable.

7.2.5.5. RIM

Specify RGB interface mode when the RGB interface is used. This register is valid when RM is set to "1". DM and this register should be set before proper display operation is performed through the RGB interface.

Table 21. RIM and RGB Interface Mode

RIM[1:0]	RGB Interface mode
00	18-bit RGB interface (one transfer per pixel)
01	16-bit RGB interface (one transfer per pixel)
10	6-bit RGB interface (three transfers per pixel)
11	Setting disable

You should notice that some display functions, which will be described later, cannot be used according to the display mode shown below.

Table 22. Display Functions and Display Modes

Function	External Clock Operation Mode	Internal Clock Operation Mode
Partial Display	Cannot be used	Can be used
Scroll Function	Cannot be used	Can be used
Rotation	Cannot be used	Can be used
Mirroring	Cannot be used	Can be used
Window Function	Cannot be used	Can be used

Display mode and RAM Access is controlled as shown below. For each display status, display mode control and RAM Access control are combined properly.

Table 23. Display State and Interface

Display State	RAM Access (RM)	Display Operation Mode (DM)
Still Pictures	System interface (RM=0)	Internal clock mode (DM=0)
Motion Pictures	RGB interface (RM=1)	External clock mode (DM=1)

Note

1. The instruction register can only be set through the system interface(SPI), when RGB interface mode.
2. The RGB interface mode(RIM) should not be set during operation.
3. For the transition flow for each operation mode, see the External Display Interface section.

7.2.5.6. VSPL

Determine the active polarity of VSYNC.

Table 24. VSPL and VSYNC

VSPL	VSYNC	Description
0 (1)	0 (1)	Valid (Valid)
0 (1)	1 (0)	Invalid (Invalid)

7.2.5.7. HSPL

Determine the active polarity of HSYNC.

Table 25. HSPL and VSYNC

HSPL	HSYNC	Description
0 (1)	0 (1)	Valid (Valid)
0 (1)	1 (0)	Invalid (Invalid)

7.2.5.8. EPL

Determine the active polarity of ENABLE for using RGB interface.

Table 26. EPL, ENABLE and RAM access

EPL	ENABLE	RAM Write	RAM Address
0 (1)	0 (1)	Valid (Valid)	Updated (Updated)
0 (1)	1 (0)	Invalid (Invalid)	Hold (Hold)

7.2.5.9. DPL

Determine the active polarity of DOTCLK.

Table 27. HSPL and VSYNC

DPL	DOTCLK	Description
0 (1)	↑(↓)	Valid (Valid)
0 (1)	↓(↑)	Invalid (Invalid)

7.2.6. Entry Mode (R03h)

R/W	RS	IB15	IB14	IB13	IB12	IB11	IB10	IB9	IB8	IB7	IB6	IB5	IB4	IB3	IB2	IB1	IB0
W	1	CLS	MDT1	MDT0	BGR	X	X	X	SS	X	X	I/D1	I/D0	X	X	X	AM

*03h Initial Value = 1000_XXX0_XX11_XXX0

7.2.6.1. CLS

This bit is used to define the color and interface bus format, When MDT0-1 = 00

CLS = 0: 65K-color mode through 8-bit(Index address 24h) or 16-bit bus(Index address 23h)

CLS = 1: 262K-color mode through 9-bit(Index address 24h) or 18-bit bus(Index address 23h)

7.2.6.2. MDT1

This bit is active on the 80-system of 8-bit bus and the data for 1-pixel is transported to the memory for 3 write cycles. This bit is on the 80-system of 16-bit bus and the data for 1-pixel is transported to the memory for 2 write cycles. When the 80-system interface mode is not set in the 8-bit or 16-bit mode, set MDT1 bit to be "0".

7.2.6.3. MDT0

When 8-bit or 16-bit 80 interface mode and MDT1 bit =1, MDT0 defines color depth for the IC.

8-bit (80-system), MDT0 = 0: 262k-color mode (3 times of 6-bit data transfer to GRAM)

8-bit (80-system), MDT0 = 1: 65k-color mode (5-bit, 6-bit, 5-bit data transfer to GRAM)

16-bit (80-system), MDT0 = 0: 262k-color mode (16-bit, 2-bit data transfer to GRAM)

16-bit (80-system), MDT0 = 1: 262k-color mode (2-bit, 16-bit data transfer to GRAM)

Table 28. Multiple Data Transfer Function 1

Interface Mode	MDT1	MDT0	Multiple Data Transfer Function
*	0	0	Default value. Multiple data transfer(MDT1-0) function is not available. Data transfer is controlled by interface mode. (Depends on S_PB, ID_MIB pads, CLS register and Index address 23h or 24h)
80/68 system 8-bit	0	1	Multiple data transfer(MDT1-0) function is not available.
	1	0	<p>The diagram illustrates the data flow for three transmissions. Each transmission consists of 6 bits of data (DB 8-3). These are arranged into three groups: R5-R0, G5-G0, and B5-B0. Arrows indicate the data being sent to these channels. The final output is labeled S(n). A note specifies n = 1 to 240.</p>

Table 29. Multiple Data Transfer Function 2

Interface Mode	MDT1	MDT0	Multiple Data Transfer Function
80/68 system 8-bit	1	1	<p>Note: n= 1 to 240</p>
80/68 system 16-bit	0	1	<p>Note: n= 1 to 120</p>
			<p>Note: n= 1 to 120</p>
80/68 system 16-bit	1	0	<p>Note: n= 1 to 240</p>
		1	<p>Note: n= 1 to 240</p>

7.2.6.4. BGR

About writing 18-bit data to GRAM, it is changed <R><G> into <G><R>.

BGR = 0; {DB[17:12], DB[11:6], DB[5:0]} is assigned to {R, G, B}. Actually the analog value that corresponds to DB[17:12] is output firstly at source output

BGR = 1; {DB[17:12], DB[11:6], DB[5:0]} is assigned to {B, G, R}. Actually the analog value that corresponds to DB[5:0] is output firstly at source output.

7.2.6.5. SS

Select the direction of the source driver channel in pixel unit.

When user changes the value of SS, memory should be updated to apply the change.

Table 30. Source Output Direction Control with SS (SS = "1")

	S240	S239	S238		S3	S2	S1
G1	"00000"H	"00001"H	"00002"H	●●●●●●●●	"000ED"H	"000EE"H	"000EF"H
G2	"00100"H	"00101"H	"00102"H	●●●●●●●●	"001ED"H	"001EE"H	"001EF"H
G3	"00200"H	"00201"H	"00202"H	●●●●●●●●	"002ED"H	"002EE"H	"002EF"H
G4	"00300"H	"00301"H	"00302"H	●●●●●●●●	"003ED"H	"003EE"H	"003EF"H
G5	"00400"H	"00401"H	"00402"H	●●●●●●●●	"004ED"H	"004EE"H	"004EF"H
G6	"00500"H	"00501"H	"00502"H	●●●●●●●●	"005ED"H	"005EE"H	"005EF"H
G7	"00600"H	"00601"H	"00602"H	●●●●●●●●	"006ED"H	"006EE"H	"006EF"H
G8	"00700"H	"00701"H	"00702"H	●●●●●●●●	"007ED"H	"007EE"H	"007EF"H
⋮	⋮	⋮	⋮	⋮	⋮	⋮	⋮
G313	"13800"H	"13801"H	"13802"H	●●●●●●●●	"138ED"H	"138EE"H	"138EF"H
G314	"13900"H	"13901"H	"13902"H	●●●●●●●●	"139ED"H	"139EE"H	"139EF"H
G315	"13A00"H	"13A01"H	"13A02"H	●●●●●●●●	"13AED"H	"13AEE"H	"13AEF"H
G316	"13B00"H	"13B01"H	"13B02"H	●●●●●●●●	"13BED"H	"13BEE"H	"13BEF"H
G317	"13C00"H	"13C01"H	"13C02"H	●●●●●●●●	"13CED"H	"13CEE"H	"13CEF"H
G318	"13D00"H	"13D01"H	"13D02"H	●●●●●●●●	"13DED"H	"13DEE"H	"13DEF"H
G319	"13E00"H	"13E01"H	"13E02"H	●●●●●●●●	"13EED"H	"13EEE"H	"13EEF"H
G320	"13F00"H	"13F01"H	"13F02"H	●●●●●●●●	"13FED"H	"13FEE"H	"13FEF"H

Note

1. For the case of SS = "0", refer to "GRAM ADDRESS MAP" presented earlier. You should notice that the order of source output is reversed.

7.2.6.6. ID

When ID[1], ID[0] = 1, the address counter (AC) is automatically increased by 1 after the data is written to the GRAM. When ID[1], ID[0] = 0, the AC is automatically decreased by 1 after the data is written to the GRAM.

The increment/decrement setting of the address counter using ID[1:0] is done independently for the horizontal address and vertical address.

7.2.6.7. AM

Set the automatic update method of the AC after the data is written to GRAM. When AM = "0", the data is continuously written in horizontally. When AM = "1", the data is continuously written vertically. When window addresses are specified, the GRAM in the window range can be written to according to the ID[1:0] and AM.

Table 31. Address Direction Setting

	ID[1:0] = "00" H: decrement V: decrement	ID[1:0] = "01" H: increment V: decrement	ID[1:0] = "10" H: decrement V: increment	ID[1:0] = "11" H: increment V: increment
AM="0" Horizontal Update				
AM="1" Vertical Update				

Note

1. When window addresses have been set, the GRAM can only be written within the window.

When AM or ID is set, the start address should be written accordingly prior to memory write.

7.2.7. Clock Control (R04h)

R/W	RS	IB15	IB14	IB13	IB12	IB11	IB10	IB9	IB8	IB7	IB6	IB5	IB4	IB3	IB2	IB1	IB0
W	1	X	X	X	X	X	X	X	X	X	X	DCR1	DCR0	X	X	X	X

*04h Initial Value = XXXX_XXXX_XX00_XXXX

7.2.7.1. DCR

Set the division ratio of booster clock, DCCLK, in external clock operation mode. In this case, DOTCLK must be input periodically and continuously.

Table 32. DCR and Division Ratio of DCCLK

DCR[1:0]	Division ratio of DCCLK
00	DOTCLK / 4
01	DOTCLK / 8
10	DOTCLK / 16
11	DOTCLK / 32

7.2.8. Display Control 1 (R05h)

R/W	RS	IB15	IB14	IB13	IB12	IB11	IB10	IB9	IB8	IB7	IB6	IB5	IB4	IB3	IB2	IB1	IB0
W	1	X	X	X	X	X	X	X	X	X	X	X	X	X	X	X	DISP_ON

*05h Initial Value = XXXX_XXXX_XXXX_XXX0

7.2.8.1. DISP_ON

Output from the Frame Memory is enabled.

This register makes No Change of contents of frame memory

DISP_ON = 0 (Display is black image),

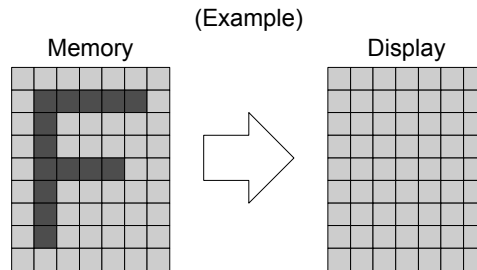

DISP_ON = 1,

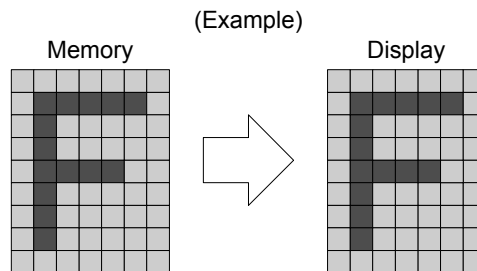

7.2.9. Display Control 2 (R06h)

R/W	RS	IB15	IB14	IB13	IB12	IB11	IB10	IB9	IB8	IB7	IB6	IB5	IB4	IB3	IB2	IB1	IB0
W	1	X	X	X	X	X	X	X	X	X	X	X	CL	X	X	TEMON	REV

*06h Initial Value = XXXX_XXXX_XXX0_XX00

7.2.9.1. CL

Sets color depth of display.

Table 33. Color Control by CL

CL	Description
0	262,144 / 65,536 colors [NOTE]
1	8 colors

Note

1. It depend on interface mode(18bit or 16bit).

7.2.9.2. TEMON

TEMON = 0, Disable the TE output signal from the SIN signal line for preventing Tearing Effect.

TEMON = 1, Enable the TE output signal from the SIN signal line for preventing Tearing Effect.

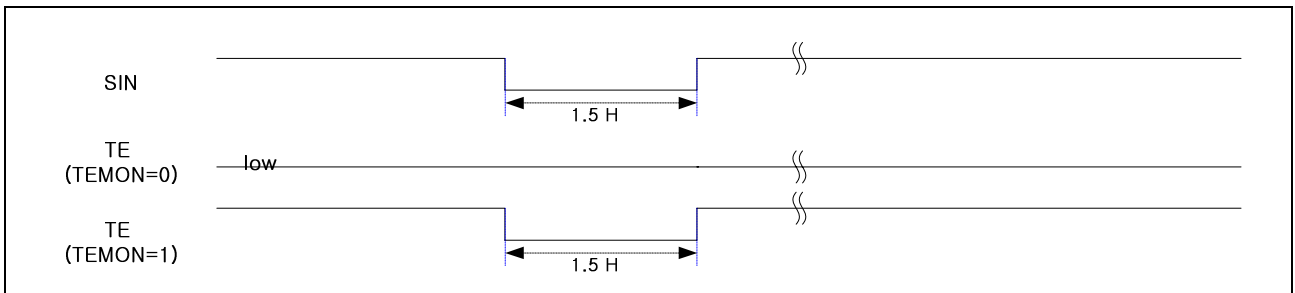

Figure 7. The Waveform of TE Signal

7.2.9.3. REV

Displays all characters and graphics display sections with reversal when REV = 1. The grayscale level can be reversed.

Table 34. REV and Source Output Level in Normal Display Area

REV	GRAM Data	Source Output Level in Displayed Area
0	6'b000000	V0 (High Voltage)
	~	~
1	6'b111111	V63(Low Voltage)
	~	~
1	6'b000000	V63 (Low Voltage)
	~	~
1	6'b111111	V0 (High Voltage)
	~	~

7.2.10. Panel Interface Control 1 (R07h, R08h)

R/W	RS	IB15	IB14	IB13	IB12	IB11	IB10	IB9	IB8	IB7	IB6	IB5	IB4	IB3	IB2	IB1	IB0
W	1	X	X	X	CLW EA4	CLW EA3	CLW EA2	CLW EA1	CLW EA0	X	X	X	X	X	X	X	X

*07h Initial Value = XXX1_0010_XXXX_XXXX

R/W	RS	IB15	IB14	IB13	IB12	IB11	IB10	IB9	IB8	IB7	IB6	IB5	IB4	IB3	IB2	IB1	IB0
W	1	X	X	X	CLW EB4	CLW EB3	CLW EB2	CLW EB1	CLW EB0	X	X	X	CLW EC4	CLW EC3	CLW EC2	CLW EC1	CLW EC0

*08h Initial Value = XXX1_0010_XXX1_0010

7.2.10.1. CLWEA, CLWEB, CLWEC

Specifies the interval time of R_sw, G_sw, B_sw respectively.

Table 35. CLWEx and the Intervals

CLWEx[4:0]	Description
0_0000	Setting disable
---	Setting disable
0_1011	Setting disable
0_1100	6 HCLK
---	---
1_0010	9 HCLK
---	---
1_1110	15 HCLK
1_1111	15.5 HCLK

Note

1. For the information of HCLK, refer to "FRAME FREQUENCY CALCULATION"

7.2.11. Panel Interface Control 2 (R09h)

R/W	RS	IB15	IB14	IB13	IB12	IB11	IB10	IB9	IB8	IB7	IB6	IB5	IB4	IB3	IB2	IB1	IB0
W	1	X	X	X	X	X	X	X	X	X	SHE2	SHE1	SHE0	X	CLT E2	CLT E1	CLT E0

*09h Initial Value = XXXX_XXXX_X010_X010

7.2.11.1. SHE

Specify the latency of G_sw and B_sw.

Table 36. SHE and the Latency of G_sw and B_sw

SHE[2:0]	Description
000	Setting disable
001	0.5 HCLK
010	1 HCLK
---	---
110	3 HCLK
111	3.5 HCLK

7.2.11.2. CLTE

Specify the falling position of R_sw.

Table 37. CLTE and the falling position of R_sw

CLTE[2:0]	Description
000	Setting disable
001	0.5 HCLK
010	1 HCLK
011	1.5 HCLKs
---	---
110	3 HCLKs
111	3.5 HCLKs

Note

1. CLWEA + CLWEB + CLWEC + SHE + CLTE ≤ 32 HCLK

7.2.12. Device Code Read (R0Fh)

R/W	RS	IB15	IB14	IB13	IB12	IB11	IB10	IB9	IB8	IB7	IB6	IB5	IB4	IB3	IB2	IB1	IB0
W	1	0	1	1	0	0	0	1	1	1	1	0	1	0	1	1	0

You can read device code('63D6h') by index 0Fh.

7.2.13. Stand By (R10h)

R/W	RS	IB15	IB14	IB13	IB12	IB11	IB10	IB9	IB8	IB7	IB6	IB5	IB4	IB3	IB2	IB1	IB0
W	1	X	X	X	X	X	X	X	X	X	X	X	X	X	NAP	X	STB

*10h Initial Value = XXXX_XXXX_XXXX_X0X1

7.2.13.1. STB

When STB = "1", S6E63D6 enters Standby mode, where display operation completely stops including the internal R-C oscillation. Furthermore, no external clock pulses are supplied.

Standby mode cancel ; STB = "0"

7.2.13.2. NAP

It is for MDDI I/F.

When NAP = "1", S6E63D6 enters NAP mode, where display operation completely stops except the internal R-C oscillation (if STB = 0). NAP mode is the same state with the STB mode but internal R-C oscillation operates.

Note

1. The default of STB for MDDI client is "0" to enable MDDI I/F after Reset is applied.
2. NAP is only valid MDDI I/F(when MDDI_EN = 1), Even if NAP is '1' at other I/F(MDDI_EN = 0), S6E63D6 does not enter the NAP mode.

7.2.14. Power GEN 1 (R12h)

R/W	RS	IB15	IB14	IB13	IB12	IB11	IB10	IB9	IB8	IB7	IB6	IB5	IB4	IB3	IB2	IB1	IB0
W	1	X	X	X	X	X	X	X	X	X	X	X	X	VC3	VC2	VC1	VC0

*12h Initial Value = XXXX_XXXX_XXXX_1000

7.2.14.1. VCI1

Reference voltage of VLOUT1, VLOUT2 and VLOUT3

Table 38. The Setting of VCI1

VC[3:0]	VCI1 [Without Load]
0000	2.10 V
0001	2.15 V
0010	2.20 V
0011	2.25 V
0100	2.30 V
0101	2.35 V
0110	2.40 V
0111	2.45 V
1000	2.50 V
1001	2.55 V
1010	2.60 V
1011	2.65 V
1100	2.70 V
1101	2.75 V
1110	Setting disable
1111	Setting disable

Note

1. Set VCI1 in the range of $VCI > VCI1 + 0.3V$

7.2.15. Power GEN 2 (R13h)

R/W	RS	IB15	IB14	IB13	IB12	IB11	IB10	IB9	IB8	IB7	IB6	IB5	IB4	IB3	IB2	IB1	IB0
W	1	X	X	VINT3	VINT2	VINT1	VINT0	X	X	X	X	X	X	X	X	X	X

*13h Initial Value = XX01_01XX_XXXX_XXXX

7.2.15.1. VINT

VINT[3:0] set VINT (control voltage of OLED Panel). It can be amplified -2.0 to -0.5 times of VCIR.

Table 39. The Setting of VINT

VINT[3:0]	VINT value
0000	-1.0 V
0001	-1.2 V
0010	-1.4 V
0011	-1.6 V
0100	-1.8 V
0101	-2.0 V
0110	-2.2 V
0111	-2.4 V
1000	-2.6 V
1001	-2.8 V
1010	-3.0 V
1011	-3.2 V
1100	-3.4 V
1101	-3.6 V
1110	-3.8 V
1111	-4.0 V

Note

1. Set VINIT in the range of $VINT > V_{LOUT3} + 1.0V$

7.2.16. Power GEN 3 (RF8h)

R/W	RS	IB15	IB14	IB13	IB12	IB11	IB10	IB9	IB8	IB7	IB6	IB5	IB4	IB3	IB2	IB1	IB0
W	1	X	X	X	X	X	X	X	X	X	X	X	VGH4	VGH3	VGH2	VGH1	VGH0

*F8h Initial Value = XXXX_XXXX_XXX1_0100

7.2.16.1. VGH

VGH[4:0] set VGH (High Voltage Level for Gate).

Table 40. The Setting of VGH

VGH[4:0]	VGH value	VGH[4:0]	VGH value
00000	Setting disable	10000	5.2 V
00001	Setting disable	10001	5.4 V
00010	Setting disable	10010	5.6 V
00011	Setting disable	10011	5.8 V
00100	Setting disable	10100	6.0 V
00101	3.0 V	10101	6.2 V
00110	3.2 V	10110	6.4 V
00111	3.4 V	10111	6.6 V
01000	3.6 V	11000	6.8 V
01001	3.8 V	11001	7.0 V
01010	4.0 V	11010	7.2 V
01011	4.2 V	11011	7.4 V
01100	4.4 V	11100	7.6 V
01101	4.6 V	11101	7.8 V
01110	4.8 V	11110	8.0 V
01111	5.0 V	11111	Setting disable

Note

1. Set VGH in the range of $VGH < V_{LOUT2} - 1.0V$

7.2.17. Power GEN 4 (RF9h)

R/W	RS	IB15	IB14	IB13	IB12	IB11	IB10	IB9	IB8	IB7	IB6	IB5	IB4	IB3	IB2	IB1	IB0
W	1	X	X	X	X	X	X	X	X	X	X	X	VGL4	VGL3	VGL2	VGL1	VGL0

*F9h Initial Value = XXXX_XXXX_XXX1_0100

7.2.17.1. VGL

VGL[4:0] bits set VGL (Low Voltage Level for Gate).

Table 41. The Setting of VGL

VGL[4:0]	VGL value	VGL[4:0]	VGL value
00000	Setting disable	10000	-5.2 V
00001	Setting disable	10001	-5.4 V
00010	Setting disable	10010	-5.6 V
00011	Setting disable	10011	-5.8 V
00100	Setting disable	10100	-6.0 V
00101	-3.0 V	10101	-6.2 V
00110	-3.2 V	10110	-6.4 V
00111	-3.4 V	10111	-6.6 V
01000	-3.6 V	11000	-6.8 V
01001	-3.8 V	11001	-7.0 V
01010	-4.0 V	11010	-7.2 V
01011	-4.2 V	11011	-7.4 V
01100	-4.4 V	11100	-7.6 V
01101	-4.6 V	11101	-7.8 V
01110	-4.8 V	11110	-8.0 V
01111	-5.0 V	11111	Setting disable

Note

1. Set VGL in the range of $VGL > V_{LOUT3} + 1.0V$

7.2.18. Power Booster Control (R14h)

R/W	RS	IB15	IB14	IB13	IB12	IB11	IB10	IB9	IB8	IB7	IB6	IB5	IB4	IB3	IB2	IB1	IB0
W	1	X	DC22	DC21	DC20	X	DC12	DC11	DC10	X	X	X	X	X	X	BT1	BT0

*14h Initial Value = X100_X010_XXXX_XX10

7.2.18.1. DC2

DC2[2:0] is the operating frequency in the booster circuit 2 is selected.

7.2.18.2. DC1

DC1[2:0] is the operating frequency in the booster circuit 1 is selected.

Table 42. The Setting of DC2 and DC1

DC2[2:0]	Cycle in Booster Circuit 2		DC1[2:0]	Booster Cycle in Booster Circuit 1	
	DM=0	DM=1		DM=0	DM=1
000	OSC_CK/16	DCCLK/16	000	OSC_CK/16	DCCLK/16
001	OSC_CK/24	DCCLK/24	001	OSC_CK/24	DCCLK/24
010	OSC_CK/32	DCCLK/32	010	OSC_CK/32	DCCLK/32
011	OSC_CK/48	DCCLK/48	011	OSC_CK/48	DCCLK/48
100	OSC_CK/64	DCCLK/64	100	OSC_CK/64	DCCLK/64
101	OSC_CK/96	DCCLK/96	101	OSC_CK/96	DCCLK/96
110	OSC_CK/128	DCCLK/128	110	OSC_CK/128	DCCLK/128
111	OSC_CK/256	DCCLK/256	111	OSC_CK/256	DCCLK/256

Note

1. DM is display method. DCCLK is for external I/F. See instruction R02h, R04h.

7.2.18.3. BT

BT[1:0] switch the output factor of booster. Adjust scale factor of the booster circuit by the voltage used.

Table 43. The Setting of BT

BT[1:0]	VLOUT1	VLOUT2	VLOUT3
00	VCI1 + VCI	$(VCI \times 2) + (VCI1 \times 2)$	$-((VCI \times 2) + (VCI1 \times 2))$
01	VCI1 + VCI	$(VCI \times 2) + (VCI1 \times 2)$	$-((VCI \times 2) + VCI1)$
10	VCI1 + VCI	$VCI + (VCI1 \times 2)$	$-((VCI \times 2) + (VCI1 \times 2))$
11	VCI1 + VCI	$VCI + (VCI1 \times 2)$	$-((VCI \times 2) + VCI1)$

Note

1. $(VLOUT2 - VLOUT3) < 20.0 V$

7.2.19. Oscillator Control (R18h)

R/W	RS	IB15	IB14	IB13	IB12	IB11	IB10	IB9	IB8	IB7	IB6	IB5	IB4	IB3	IB2	IB1	IB0
W	1	X	X	X	X	X	X	X	X	X	X	RAD J5	RAD J4	RAD J3	RAD J2	RAD J1	RAD J0

*18h Initial Value = XXXX_XXXX_XX01_1111

7.2.19.1. RADJ

Select the oscillation frequency of internal oscillator.

Table 44. The Setting of RADJ

RADJ[5:0]	Oscillation Speed	RADJ[5:0]	Oscillation Speed
000000	x 0.543(Min.)	010101	x 0.782
000001	x 0.551	010110	x 0.800
000010	x 0.560	010111	x 0.818
000011	x 0.568	011000	x 0.835
000100	x 0.578	011001	x 0.855
000101	x 0.586	011010	x 0.877
000110	x 0.596	011011	x 0.899
000111	x 0.606	011100	x 0.921
001000	x 0.615	011101	x 0.946
001001	x 0.626	011110	x 0.972
001010	x 0.637	011111	x 1.000
001011	x 0.647	100000	x 1.037
001100	x 0.660	100001	x 1.067
001101	x 0.671	100010	x 1.101
001110	x 0.685	100011	x 1.135
001111	x 0.697	100100	x 1.172
010000	x 0.707	100101	x 1.212
010001	x 0.721	100110	x 1.256
010010	x 0.736	100111	x 1.302
010011	x 0.751	101000	X1.352(Max.)
010100	x 0.766	101001 ~ 111111	Setting disable

7.2.20. Source Driver Control (R1Ah)

R/W	RS	IB15	IB14	IB13	IB12	IB11	IB10	IB9	IB8	IB7	IB6	IB5	IB4	IB3	IB2	IB1	IB0
W	1	X	X	X	X	X	X	X	X	X	X	GAM MA_T EST	SDU M_ON	X	SAP 2	SAP 1	SAP 0

*1Ah Initial Value = XXXX _XXXX_XX00_X101

7.2.20.1. GAMMA_TEST

When GAMMA_TEST='1', V0/V63 pads are shorted to each gamma voltage V0/V63 and gamma voltage V0/V63 can be monitored or be forced by external voltage level.

Table 45. The Setting of GAMMA_TEST

GAMMA_TEST	V0 / V63
0	Hi-z
1	V0 / V63

7.2.20.2. SDUM_ON

When SDUM_ON='1', SOUT_DUM1 and SOUT_DUM240 pads are shorted to SOUT[1], SOUT[240] output and can be monitored.

Table 46. The Setting of SDUM_ON

SDUM_ON	SOUT_DUM1 / SOUT_DUM240
0	Hi-z
1	SOUT[1] / SOUT[240]

7.2.20.3. SAP

Adjust the slew-rate of the operational amplifier of the source driver. If higher SAP[2:0] is set, OLED panel having higher resolution of higher frame frequency can be driven because the slew-rate of the operational amplifier is increased. But, these bits must be set as adequate value because the amount of fixed current of the operational amplifier is also adjusted. During non-display, when SAP[2:0]="000", operational amplifiers are turned off, so current consumption can be reduced

Table 47. The Setting of SAP

SAP[2:0]	Slew-Rate of Operational Amplifier	Amount of Current in Operational Amplifier
000	Operation of the operational amplifier stops.	
001	Slow	Small
010	Slow or medium	Small or medium
011	Medium	Medium
100	Medium or small fast	Medium or small large
101	Small fast	Small large
110	Fast	large
111	Big fast	Big large

7.2.21. GRAM Address Set (R20h, R21h)

R/W	RS	IB15	IB14	IB13	IB12	IB11	IB10	IB9	IB8	IB7	IB6	IB5	IB4	IB3	IB2	IB1	IB0
W	1	X	X	X	X	X	X	X	X	AD7	AD6	AD5	AD4	AD3	AD2	AD1	AD0

*20h Initial Value = XXXX _XXXX_0000_0000

R/W	RS	IB15	IB14	IB13	IB12	IB11	IB10	IB9	IB8	IB7	IB6	IB5	IB4	IB3	IB2	IB1	IB0
W	1	X	X	X	X	X	X	X	AD 16	AD 15	AD 14	AD 13	AD 12	AD 11	AD 10	AD9	AD8

*21h Initial Value = XXXX _XXX0_0000_0000

7.2.21.1. AD

You can write initial GRAM address into internal Address Counter (AC). When GRAM data is transferred through System Interface or RGB Interface, the AC is automatically updated according to AM and ID. This allows consecutive write / read without re-setting address in AC.

Ensure that the address is set within the specified window area.

When RGB interface is used (RM="1") to access GRAM, AD[16:0] will be set in the address counter at the falling edge of the VSYNC signal. And when one uses System Interface to access GRAM (RM = "0"), AD[16:0] will be set upon the execution of an instruction.

Table 48. GRAM Address Range

AD[16:0]	GRAM setting
"00000h" to "00AFh"	Bitmap data for G1
"00100h" to "01AFh"	Bitmap data for G2
"00200h" to "02AFh"	Bitmap data for G3
"00300h" to "03AFh"	Bitmap data for G4
⋮	⋮
⋮	⋮
"13C00h" to "13CEFh"	Bitmap data for G317
"13D00h" to "13DEFh"	Bitmap data for G318
"13E00h" to "13EEFh"	Bitmap data for G319
"13F00h" to "13FEFh"	Bitmap data for G320

7.2.22. Write Data to GRAM (R22h)

R/W	RS	IB15	IB14	IB13	IB12	IB11	IB10	IB9	IB8	IB7	IB6	IB5	IB4	IB3	IB2	IB1	IB0
W	1	RAM write data (WD17-0): Pad assignment varies according to the interface method. (see the following figure for more information)															
R/W	RS	WD15	WD14	WD13	WD12	WD11	WD10	WD9	WD8	WD7	WD6	WD5	WD4	WD3	WD2	WD1	WD0
W	1	When RGB-interface															

WD17-0: Input data for GRAM can be expanded to 18 bits. The expansion format varies according to the interface method. The input data selects the grayscale level. After a write, the address is automatically updated according to I/D bit settings. When 16- or 8-bit interface is in use, the write data is expanded to 18 bits by writing the MSB of the <R> data to its LSB.

When data is written to RAM used by RGB interface via the system interface, please make sure that write data conflicts do not occur.

When the 18-bit RGB interface is in use, 18-bit data is written to RAM via DB17-0 and 262,144-colors are available. When the 16-bit RGB interface is in use, the MSB is written to its LSB and 65,536-colors are available.

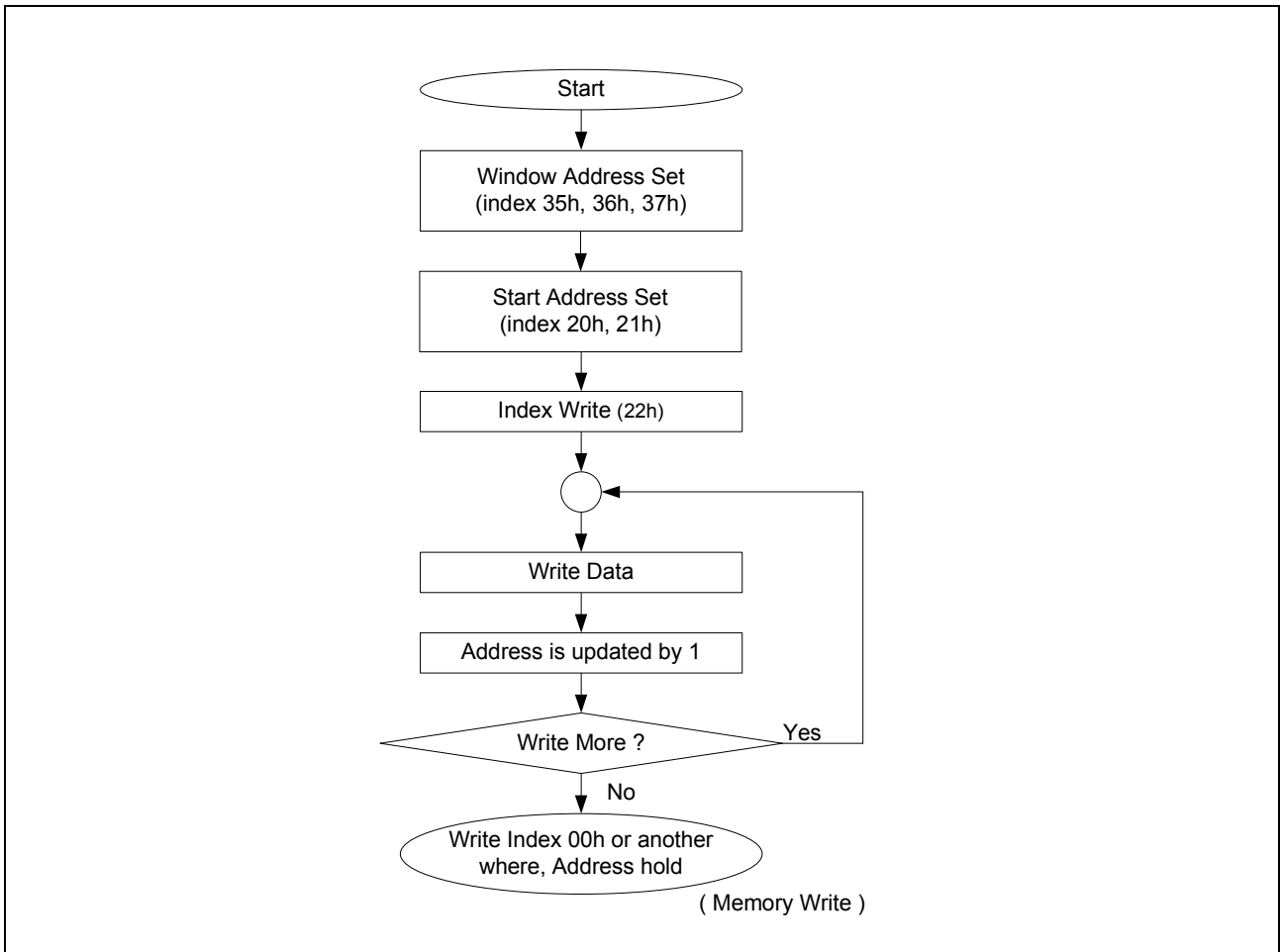

Figure 8. Memory Data Write Sequence

7.2.23. Read Data from FROM GRAM (R22h)

R/W	RS	DB 17	DB 16	DB 15	DB 14	DB 13	DB 12	DB 11	DB 10	DB 9	DB 8	DB 7	DB 6	DB 5	DB 4	DB 3	DB 2	DB 1	DB 0
R	1	RAM Read data (RD17-0): Pad assignment varies according to the interface method. (see the following figure for more information)																	

RD17-0: Read 18-bit data from the GRAM. When the data is read to the CPU, the first-word read immediately after the GRAM address setting is latched from the GRAM to the internal read-data latch. The data on the data bus (DB17-0) becomes invalid and the second-word read is normal.

In case of 16-/8-bit interface, the LSB of <R> color data will not be read.

This function is not available in RGB interface mode.

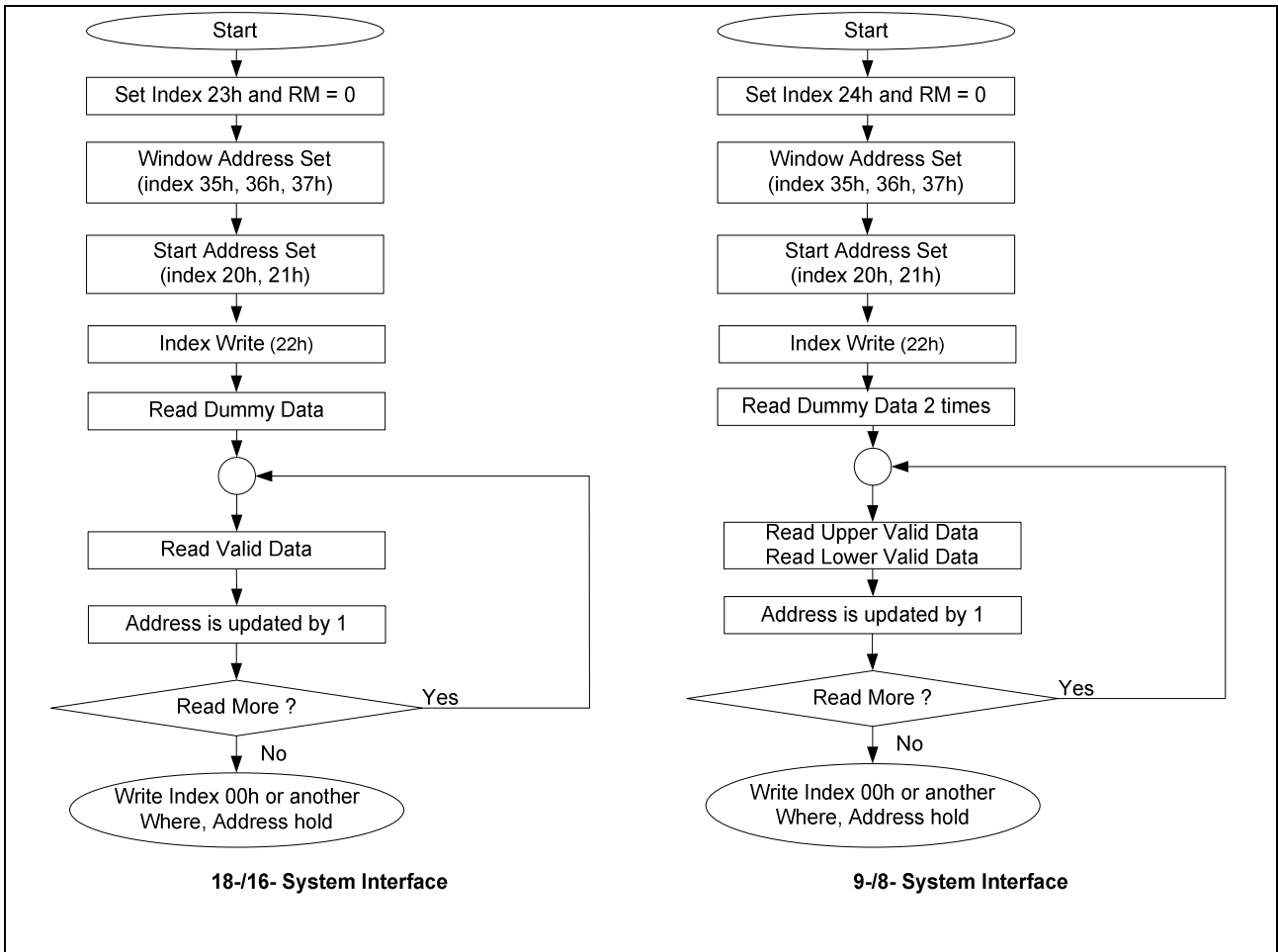

Figure 9. Memory Data Read Sequence

7.2.24. Select Data Bus 1 (R23h)

R/W	RS	IB15	IB14	IB13	IB12	IB11	IB10	IB9	IB8	IB7	IB6	IB5	IB4	IB3	IB2	IB1	IB0
W	1	Select 18-/16-bit Data Bus Interface															

7.2.25. Select Data Bus 2 (R24h)

R/W	RS	IB15	IB14	IB13	IB12	IB11	IB10	IB9	IB8	IB7	IB6	IB5	IB4	IB3	IB2	IB1	IB0
W	1	Select 9-/8-bit Data Bus Interface															

You can select system interface mode by pads and instruction as following.

Table 49. System Interface Mode

Pads			Registers				Description
MDDI_EN	S_PB	ID_MIB	Index Address	Command (CLS)	Command MDT[1]	Command MDT[0]	
0	0 (Parallel)	0 (80 mode)	Default & 24h (9/8bit)	0 (80 8bit)	0	X	80-system 8-bit 65k bus interface
					1	0	80-system 8-bit 260k bus interface
				1	1	80-system 8-bit 65k bus interface	
				1 (80 9bit)	X	X	80-system 9-bit 260k bus interface
			Index 23h (18/16bit)	0 (80 16bit)	0	0	80-system 16-bit 65k bus interface
					1	X	80-system 16-bit 260k bus interface
				1 (80 18bit)	X	X	80-system 18-bit 260k bus interface
					X	X	80-system 18-bit 260k bus interface
	1 (68 mode)	1 (68 mode)	Default & 24h (9/8bit)	0 (68 8bit)	0	X	68-system 8-bit 65k bus interface
					1	0	68-system 8-bit 260k bus interface
				1	1	68-system 8-bit 65k bus interface	
			Index 23h (18/16bit)	0 (68 9bit)	X	X	68-system 9-bit 260k bus interface
					0 (68 16bit)	0	0
				1 (68 18bit)	0	1	68-system 16-bit 260k bus interface
1	X	X	68-system 18-bit 260k bus interface				
1 (Serial)	ID	X	X	X	X	Serial peripheral interface (SPI)	
1	X		X	X	X	X	MDDI

Note

1. For details, see the Entry Mode (R03h)

7.2.26. Vertical Scroll Control 1 (R30h, R31h)

R/W	RS	IB15	IB14	IB13	IB12	IB11	IB10	IB9	IB8	IB7	IB6	IB5	IB4	IB3	IB2	IB1	IB0
W	1	X	X	X	X	X	X	X	SSA 8	SSA 7	SSA 6	SSA 5	SSA 4	SSA 3	SSA 2	SSA 1	SSA 0

*30h Initial Value = XXXX _XXX0_0000_0000

R/W	RS	IB15	IB14	IB13	IB12	IB11	IB10	IB9	IB8	IB7	IB6	IB5	IB4	IB3	IB2	IB1	IB0
W	1	X	X	X	X	X	X	X	SEA 8	SEA 7	SEA 6	SEA 5	SEA 4	SEA 3	SEA 2	SEA 1	SEA 0

*31h Initial Value = XXXX _XXX1_0011_1111

7.2.26.1. SSA

Specify scroll start address at the scroll display for vertical smooth scrolling.

Table 50. The setting of scroll start address

SSA8	SSA7	SSA6	SSA5	SSA4	SSA3	SSA2	SSA1	SSA0	Scroll Start Address
0	0	0	0	0	0	0	0	0	0 raster-row
0	0	0	0	0	0	0	0	1	1 raster-row
0	0	0	0	0	0	0	1	0	2 raster-row
0	0	0	0	0	0	0	1	1	3 raster-row
0	0	0	0	0	0	1	0	0	4 raster-row
0	0	0	0	0	0	1	0	1	5 raster-row
:									:
1	0	0	1	1	1	1	0	0	316 raster-row
1	0	0	1	1	1	1	0	1	317 raster-row
1	0	0	1	1	1	1	1	0	318 raster-row
1	0	0	1	1	1	1	1	1	319 raster-row

7.2.26.2. SEA

Specify scroll end address at the scroll display for vertical smooth scrolling.

Table 51. The setting of scroll end address

SEA8	SEA7	SEA6	SEA5	SEA4	SEA3	SEA2	SEA1	SEA0	Scroll End Address
0	0	0	0	0	0	0	0	0	0 raster-row
0	0	0	0	0	0	0	0	1	1 raster-row
0	0	0	0	0	0	0	1	0	2 raster-row
0	0	0	0	0	0	0	1	1	3 raster-row
0	0	0	0	0	0	1	0	0	4 raster-row
0	0	0	0	0	0	1	0	1	5 raster-row
:									:
1	0	0	1	1	1	1	0	0	316 raster-row
1	0	0	1	1	1	1	0	1	317 raster-row
1	0	0	1	1	1	1	1	0	318 raster-row
1	0	0	1	1	1	1	1	1	319 raster-row

Note

1. Don't set any higher raster-row than 319 ("13F"H)
2. Set SS18-10 SSA8-0, if set out of range, SSA8-0 = SS18-10.
3. Set SE18-10 SEA8-0, if set out of range, SEA8-0 = SE18-10

7.2.27. Vertical Scroll Control 2 (R32h)

R/W	RS	IB15	IB14	IB13	IB12	IB11	IB10	IB9	IB8	IB7	IB6	IB5	IB4	IB3	IB2	IB1	IB0
W	1	X	X	X	X	X	X	X	SST 8	SST 7	SST 6	SST 5	SST 4	SST 3	SST 2	SST 1	SST 0

*32h Initial Value = XXXX _XXX0_0000_0000

7.2.27.1. SST

Specify scroll start and step at the scroll display for vertical smooth scrolling. Any raster-row from the 1st to 320th can be scrolled for the number of the raster-row. After 319th raster-row is displayed, the display restarts from the first raster-row. When SST8-0 = 00000000, Vertical Scroll Function is disabled.

Table 52. The setting of scroll end address

SST8	SST7	SST6	SST5	SST4	SST3	SST2	SST1	SST0	Scroll Step
0	0	0	0	0	0	0	0	0	0 raster-row
0	0	0	0	0	0	0	0	1	1 raster-row
0	0	0	0	0	0	0	1	0	2 raster-row
0	0	0	0	0	0	0	1	1	3 raster-row
0	0	0	0	0	0	1	0	0	4 raster-row
0	0	0	0	0	0	1	0	1	5 raster-row
:									:
1	0	0	1	1	1	1	0	0	316 raster-row
1	0	0	1	1	1	1	0	1	317 raster-row
1	0	0	1	1	1	1	1	0	318 raster-row
1	0	0	1	1	1	1	1	1	319 raster-row

Note

- Don't set any higher raster-row than 319 ("13F"H)
- Set SS18-10 < SSA8-0 + SST8-0 SEA8-0 SE18-10, if set out of range, Scroll function is disabled.

This figure explains the vertical scroll display mode.

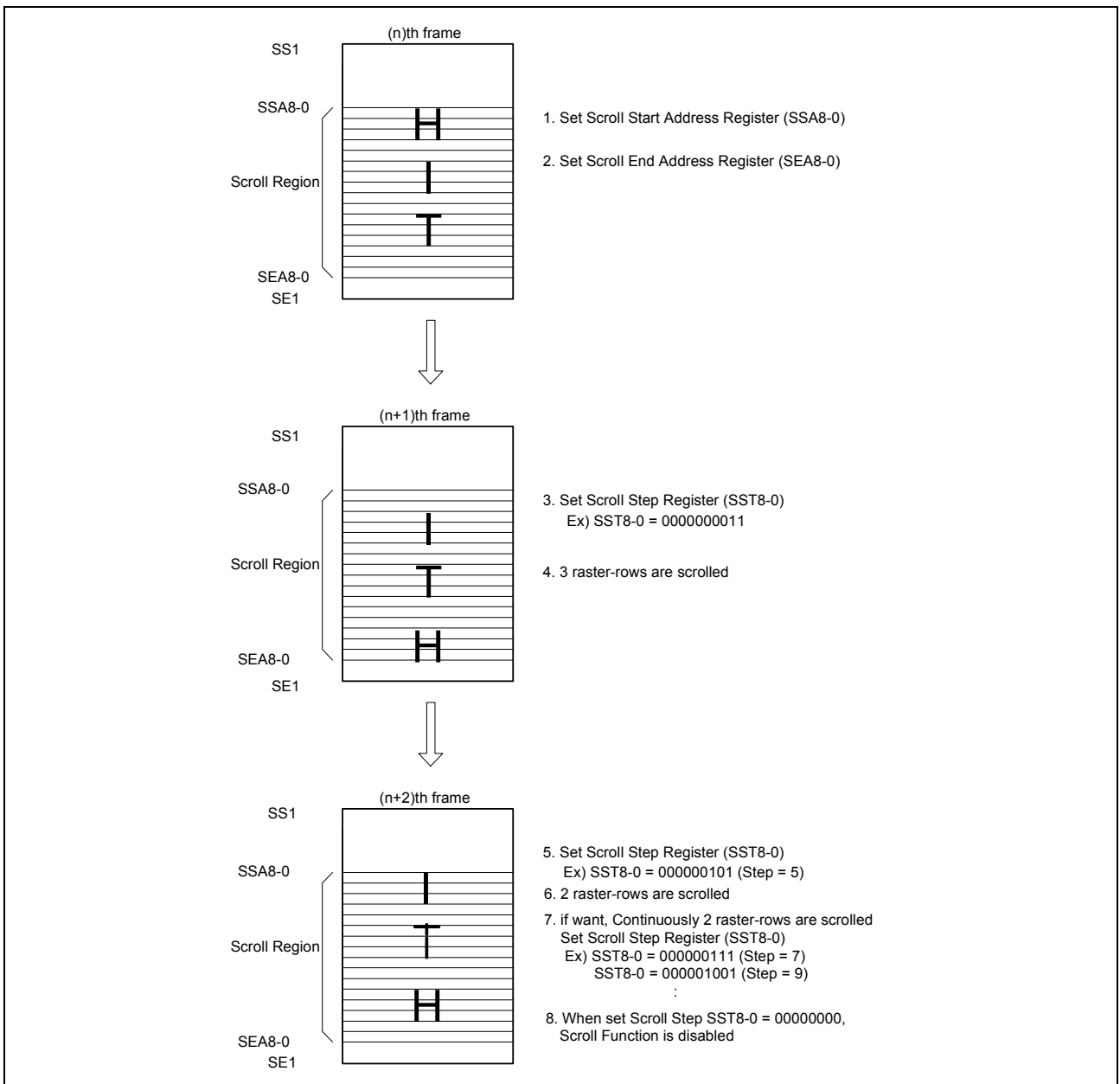

Figure 10. Vertical Scroll Display

7.2.28. Partial Screen Driving Position (R33h, R34h)

R/W	RS	IB15	IB14	IB13	IB12	IB11	IB10	IB9	IB8	IB7	IB6	IB5	IB4	IB3	IB2	IB1	IB0
W	1	X	X	X	X	X	X	X	SS1 8	SS1 7	SS1 6	SS1 5	SS1 4	SS1 3	SS1 2	SS1 1	SS1 0

*33h Initial Value = XXXX _XXX0_0000_0000

R/W	RS	IB15	IB14	IB13	IB12	IB11	IB10	IB9	IB8	IB7	IB6	IB5	IB4	IB3	IB2	IB1	IB0
W	1	X	X	X	X	X	X	X	SE1 8	SE1 7	SE1 6	SE1 5	SE1 4	SE1 3	SE1 2	SE1 1	SE1 0

*34h Initial Value = XXXX _XXX1_0011_1111

7.2.28.1. SS1

Specify the drive starting position for the first screen in a line unit. The OLED driving starts from the 'set value +1' gate driver.

7.2.28.2. SE1

Specify the driving end position for the screen in a line unit. The OLED driving is performed to the 'set value + 1' gate driver. For instance, when SS18–10 = 019h and SE18–10 = 029h are set, the OLED driving is performed from G26 to G42, and non-display driving is performed for G1 to G25, G43, and others. Ensure that SS18–10 ≤ SE18–10 13Fh.

Note

1. DO NOT set the partial setting when the operation is in the normal display condition. Set this register only when in the partial display condition.

Ex) SS18-0=007h and SE18-0=010h are performed from G8 to G17.

The S6E63D6 can select and drive partial screens at any position with the screen-driving position registers (R33h, R34h). Any partial screens required for display are selectively driven and reducing OLED-driving voltage and power consumption

This figure explains the partial display mode.

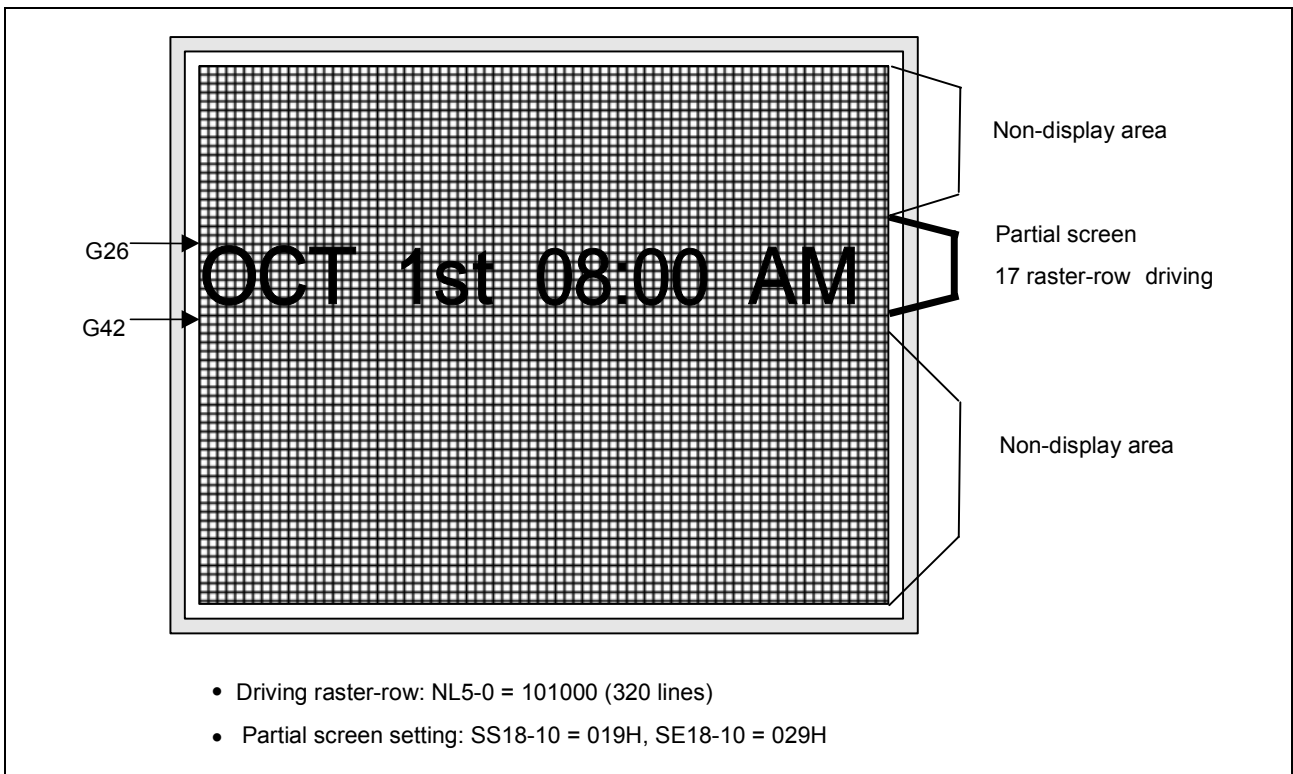

Figure 11. Driving On Partial Screen

7.2.28.3. Restriction on Partial Display Area Setting

The following restrictions must be satisfied when setting the start line (SS18 to 10) and end line (SE18 to 10) of the partial screen driving position register (R33h, R34h) for the S6E63D6. Note that incorrect display may occur if the restrictions are not satisfied.

Table 53. Restrictions on the Partial Screen Driving Position Register Setting

Register setting	Display operation
$(SE18\ to\ 10) - (SS18\ to\ 10) = NL * 8$	Full screen display Normally displays (SS18 to 10) to (SE18 to 10)
$(SE18\ to\ 10) - (SS18\ to\ 10) < NL * 8$	Partial display Normally displays (SS18 to 10) to (SE18 to 10) Black display for all other times (RAM data is not related at all)
$(SE18\ to\ 10) - (SS18\ to\ 10) > NL * 8$	Setting disabled

Note
1. $000h \leq SS18\ to\ 10$ $SE18\ to\ 10 \leq 13Fh7$

7.2.29. Vertical RAM Address Position (R35h, R36h)

R/W	RS	IB15	IB14	IB13	IB12	IB11	IB10	IB9	IB8	IB7	IB6	IB5	IB4	IB3	IB2	IB1	IB0
W	1	X	X	X	X	X	X	X	VSA 8	VSA 7	VSA 6	VSA 5	VSA 4	VSA 3	VSA 2	VSA 1	VSA 0

*35h Initial Value = XXXX _XXX0_0000_0000

R/W	RS	IB15	IB14	IB13	IB12	IB11	IB10	IB9	IB8	IB7	IB6	IB5	IB4	IB3	IB2	IB1	IB0
W	1	X	X	X	X	X	X	X	VEA 8	VEA 7	VEA 6	VEA 5	VEA 4	VEA 3	VEA 2	VEA 1	VEA 0

*36h Initial Value = XXXX _XXX1_0011_1111

7.2.29.1. VSA / VEA

Specify the vertical start/end positions of a window for access in memory. Data can be written to the GRAM from the address specified by VSA8-0 to the address specified by VEA8-0. Note that an address must be set before RAM is written.

7.2.30. Horizontal RAM Address Position (R37h)

R/W	RS	IB15	IB14	IB13	IB12	IB11	IB10	IB9	IB8	IB7	IB6	IB5	IB4	IB3	IB2	IB1	IB0
W	1	HSA 7	HAS 6	HAS 5	HAS 4	HAS 3	HAS 2	HAS 1	HAS 0	HES 7	HEA 6	HEA 5	HEA 4	HEA 3	HEA 2	HEA 1	HEA 0

*37h Initial Value = 0000 _0000_1110_1111

7.2.30.1. HAS / HEA

Specify the horizontal start/end positions of a window for access in memory. Data can be written to the GRAM from the address specified by HSA7-0 to the address specified by HEA 7-0. Note that an address must be set before RAM is written.

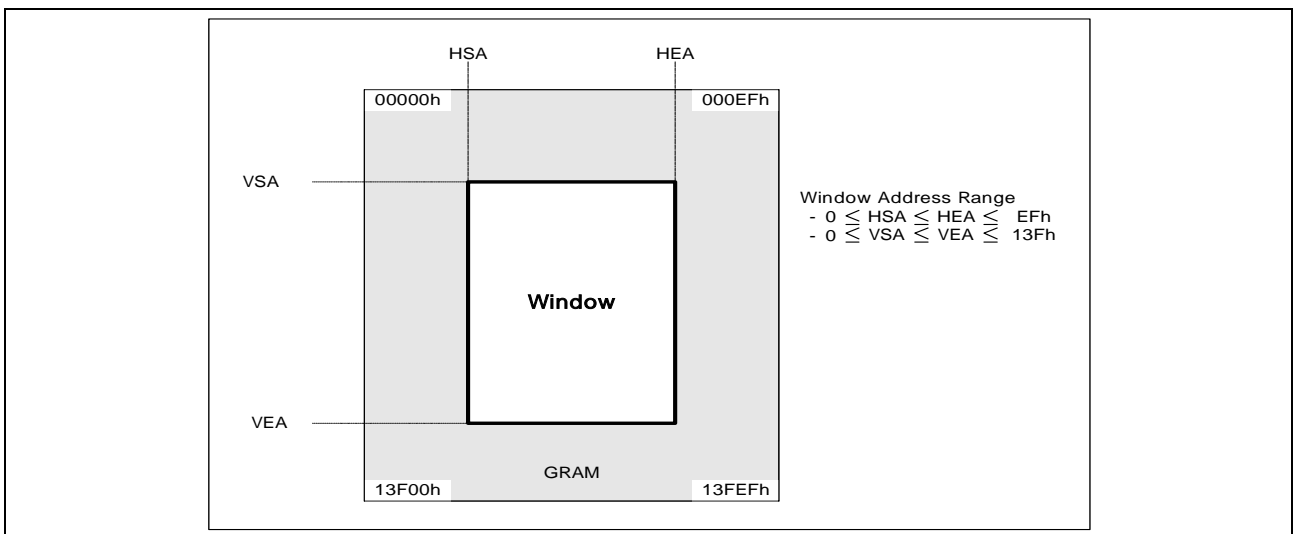

Figure 12. Window Address Function

Note

1. Ensure that the window addresses are within the GRAM address space.

7.2.31. Client Initiated Wake up (R38h)

R/W	RS	IB15	IB14	IB13	IB12	IB11	IB10	IB9	IB8	IB7	IB6	IB5	IB4	IB3	IB2	IB1	IB0
W	1	X	X	X	X	X	X	X	X	X	X	X	X	X	X	X	VWAKE_EN

*38h Initial Value = XXXX _XXXX _XXXX _XXX0

7.2.31.1. VWAKE_EN

When VWAKE_EN is 1, client initiated wake-up is enabled. But parameter data IB[15:1] must be "0000h", otherwise, client initiated wake-up is disabled.

7.2.32. MDDI Link Wake up Start Position (R39h)

R/W	RS	IB15	IB14	IB13	IB12	IB11	IB10	IB9	IB8	IB7	IB6	IB5	IB4	IB3	IB2	IB1	IB0
W	1	WKL 8	WKL 7	WKL 6	WKL 5	WKL 4	WKL 3	WKL 2	WKL 1	WKL 0	X	WKF 3	WKF 2	WKF 1	WKF 0	X	X

*39h Initial Value = 0000 _0000 _0X00 _00XX

7.2.32.1. WKF

When client initiated wake-up is used at MDDI, the frame position that data is updated is set by the value of WKF 3-0. The range of WKF is from '0000' to '1111'.

If WKF is '0000', data is updated at the first frame, and if WKF is "1111" data update starts after 16th frame.

7.2.32.2. WKL

When client initiated wakeup is used at MDDI, data is updated at the line the value of WKL 8-0 in the frame that is set by WKF 3-0. The range of WKL is from '000h' to '1FFh'.

If WKL is '000h', data is updated at the first line, and if WKL is '0FFh', data update starts at the 256th line.

Setting of WKF and WKL is needed for client-initiated link wake-up.

For example, WKF is '0010' and WKL is '0001', data is updated at second line of third frame.

7.2.33. Sub Panel Control 1 (R3Ah, R3Bh)

R/W	RS	IB15	IB14	IB13	IB12	IB11	IB10	IB9	IB8	IB7	IB6	IB5	IB4	IB3	IB2	IB1	IB0
W	1	X	X	X	X	X	X	X	X	SUB _SE L7	SUB _SE L6	SUB _SE L5	SUB _SE L4	SUB _SE L3	SUB _SE L2	SUB _SE L1	SUB _SE L0

*3Ah Initial Value = XXXX _XXXX_0111_1010

R/W	RS	IB15	IB14	IB13	IB12	IB11	IB10	IB9	IB8	IB7	IB6	IB5	IB4	IB3	IB2	IB1	IB0
W	1	X	X	X	X	X	X	X	X	SUB _WR 7	SUB _WR 6	SUB _WR 5	SUB _WR 4	SUB _WR 3	SUB _WR 2	SUB _WR 1	SUB _WR 0

*3Bh Initial Value = XXXX _XXXX_0010_0010

7.2.33.1. SUB_SEL

SUB_SEL is the index of main/sub panel selection. Initial value of SUB_SEL is '7Ah'.

In MDDI mode, If written register address is '7Ah' (initial state: SUB_SEL is '7Ah') and register data is 0001h', then main panel is selected, and if that is '0000h', then sub panel is selected.

Using SUB_SEL register, Main / Sub panel selection index change is possible.

7.2.33.2. SUB_WR

SUB_WR is the index of sub panel data write. Initial value of SUB_WR is '22h'.

When MDDI host transfer GRAM data to sub panel driver IC via video stream packet, SUB_WR (initially 22h), index for GRAM access is automatically transferred before GRAM data transfer.

When sub panel driver IC uses other address, 22h address have to be changed. Then user can change SUB_WR value from 22h to other value.

7.2.34. Sub Panel Control 2 (R3Ch)

R/W	RS	IB15	IB14	IB13	IB12	IB11	IB10	IB9	IB8	IB7	IB6	IB5	IB4	IB3	IB2	IB1	IB0
W	1	X	X	X	X	X	X	X	X	FCV _EN	X	X	X	MPU _MO DE	STN _EN	SUB _IM1	SUB _IM0

*3Ch Initial Value = XXXX _XXXX_0XXX_0001

7.2.34.1. SUB_IM

Specify the sub-panel interface mode.

Table 54. Sub Panel Interface Mode

SUB_IM1	SUB_IM0	Interface
0	0	Setting disable
0	1	9bit Interface mode
1	0	Setting disable
1	1	8bit Interface mode

7.2.34.2. STN_EN

Specify the panel property.

STN_EN = "1": STN panel.

STN_EN = "0": TFT panel.

7.2.34.3. MPU_MODE

Specify the MPU interfaces

MPU_MODE = "1": 68 mode

MPU_MODE = "0": 80 mode

7.2.34.4. FCV_EN

FCV_EN is data format conversion enable signal

FCV_EN = "1": 16 bit data format conversion (not used)

FCV_EN = "0": current 16bit data format

7.2.35. Test Key Command (R60h)

R/W	RS	IB15	IB14	IB13	IB12	IB11	IB10	IB9	IB8	IB7	IB6	IB5	IB4	IB3	IB2	IB1	IB0
W	1	X	X	X	X	X	X	X	X	0	0	0	0	1	1	1	1

Test Key Command is a protection command. When Test Key Command(0Fh) is applied, MTP_WRB and MTP_ERB are valid

7.2.36. MTP Control (R61h)

R/W	RS	IB15	IB14	IB13	IB12	IB11	IB10	IB9	IB8	IB7	IB6	IB5	IB4	IB3	IB2	IB1	IB0
W	1	X	X	X	X	X	X	X	MTP_WRB	X	X	X	MTP_SEL	X	X	X	MTP_ERB

*61h Initial Value = XXXX _XXX1 _XXX1 _XXX1

7.2.36.1. MTP_WRB

MTP Write enable signal. If you want to write data to MTP cell, set MTP_WRB = 0

7.2.36.2. MTP_SEL

Select MTP value or register value added to CR5[6:0], CG5[6:0], CB5[6:0], CR3[5:0], CG3[5:0], and CB3[5:0]

7.2.36.3. MTP_ERB

Enable for MTP initial or erase. When MTP_ERB = 0, MTP initialization or erase is enabled.

7.2.37. MTP Register Setting (R62h, R63h, R64h, R65h)

R/W	RS	IB15	IB14	IB13	IB12	IB11	IB10	IB9	IB8	IB7	IB6	IB5	IB4	IB3	IB2	IB1	IB0
W	1	X	X	X	X	R21 _BT 2	R21 _BT 1	R21 _BT 0	X	X	X	X	X	R63 _BT 3	R63 _BT 2	R63 _BT 1	R63 _BT 0

*62h Initial Value = XXXX_000X_XXXX_0000

R/W	RS	IB15	IB14	IB13	IB12	IB11	IB10	IB9	IB8	IB7	IB6	IB5	IB4	IB3	IB2	IB1	IB0
W	1	X	X	X	X	G21 _BT 2	G21 _BT 1	G21 _BT 0	X	X	X	X	X	G63 _BT 3	G63 _BT 2	G63 _BT 1	G63 _BT 0

*63h Initial Value = XXXX_000X_XXXX_0000

R/W	RS	IB15	IB14	IB13	IB12	IB11	IB10	IB9	IB8	IB7	IB6	IB5	IB4	IB3	IB2	IB1	IB0
W	1	X	X	X	X	B21 _BT 2	B21 _BT 1	B21 _BT 0	X	X	X	X	X	B63 _BT 3	B63 _BT 2	B63 _BT 1	B63 _BT 0

*64h Initial Value = XXXX_000X_XXXX_0000

R/W	RS	IB15	IB14	IB13	IB12	IB11	IB10	IB9	IB8	IB7	IB6	IB5	IB4	IB3	IB2	IB1	IB0
W	1	X	X	X	X	X	X	X	X	X	X	X	X	X	E_OS T2	E_OS T1	E_OS T0

*65h Initial Value = XXXX_XXXX_XXXX_X000

7.2.37.1. R21_BT, G21_BT, B21_BT

V21(Red, Green, Blue) offset compensation value.

Table 55. The Setting of R(G, B)21_BT

R(G, B)21_BT	Complement Offset Value
011	+3
010	+2
001	+1
000	0
111	-1
110	-2
101	-3
100	-4

7.2.37.2. R63_BT, G63_BT, B63_BT

V63(Red, Green, Blue) offset compensation value.

Table 56. The Setting of R(G, B)63_BT

R(G, B)63_BT	Complement Offset Value	R(G, B)63_BT	Complement Offset Value
0111	+7	1111	-1
0110	+6	1110	-2
0101	+5	1101	-3
0100	+4	1100	-4
0011	+3	1011	-5
0010	+2	1010	-6
0001	+1	1001	-7
0000	0	1000	-8

7.2.37.3. E_OST

ELVDD offset compensation value.

Table 57. The Setting of E_OST

E_OST	Complement Offset Value
011	+3
010	+2
001	+1
000	0
111	-1
110	-2
101	-3
100	-4

This block diagram shows the sequence for compensation of V0, V21, V63 value.

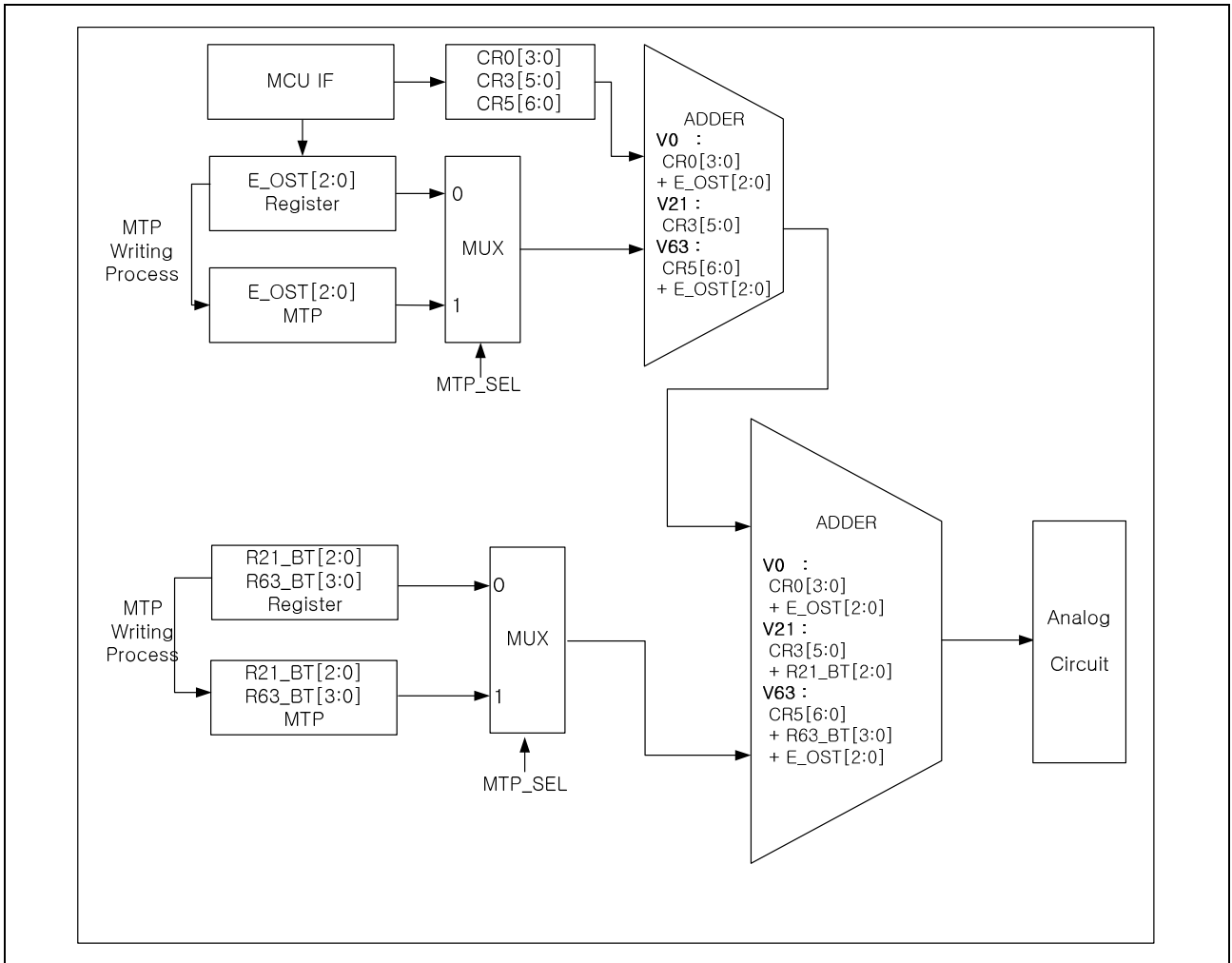

Figure 13. The Block diagram of sequence for V0, V21, V63 compensation

This figure shows the flow of MTP initialization, programing and reading.

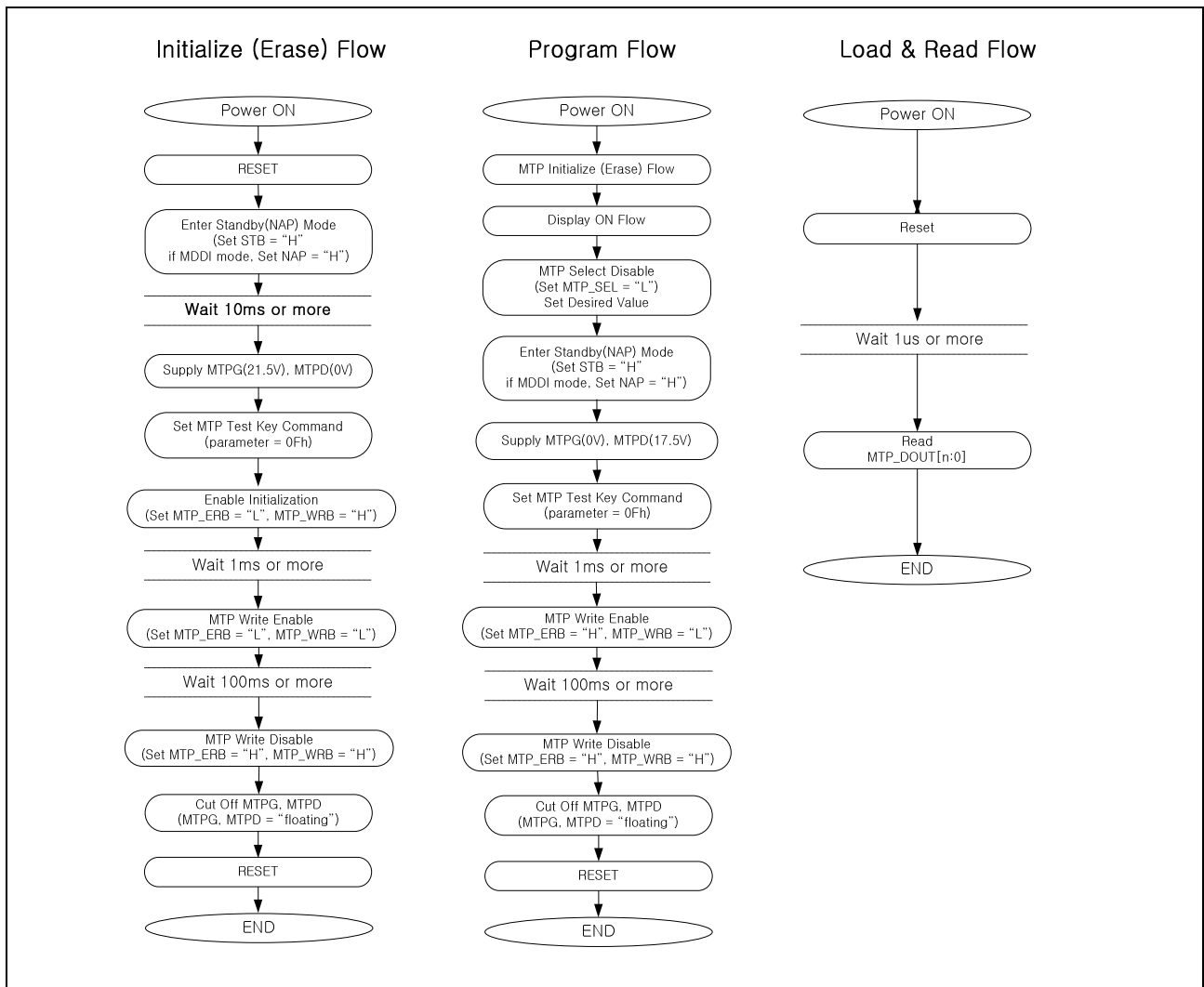

Figure 14. MTP Initialization, Programing and Reading

This figure explains the timing of MTP programming.

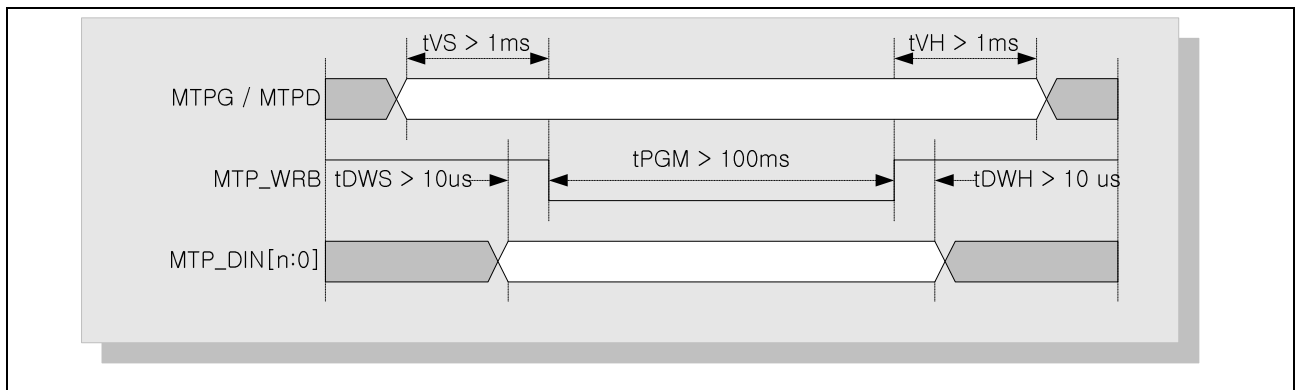

Figure 15. Timing of MTP Programing

Table 58. MTP Writing Time

Timing	Min	Max	Unit
t_{VS}	1	-	ms
t_{VH}	1	-	ms
t_{DWS}	10	-	μs
t_{DWH}	10	-	μs
t_{PGM}	100	200	Ms

Table 59. MTPG, MTPD Voltage Tolerance

Item	Operation	Min	Typ	Max	Unit
Tolerance of MTPG	Initialize (Erase)	21.0	21.5	22.0	V
	Program (Write)	-	0	-	V
Tolerance of MTPD	Initialize (Erase)	-	0	-	V
	Program (Write)	17.0	17.5	18.0	V

7.2.38. GPIO Control (R66h, R67h, R68h, R69h, R6Ah)

R/W	RS	IB15	IB14	IB13	IB12	IB11	IB10	IB9	IB8	IB7	IB6	IB5	IB4	IB3	IB2	IB1	IB0
W	1	X	X	X	X	X	X	GPI O9	GPI O8	GPI O7	GPI O6	GPI O5	GPI O4	GPI O3	GPI O2	GPI O1	GPI O0

*66h Initial Value = XXXX_XX00_0000_0000

R/W	RS	IB15	IB14	IB13	IB12	IB11	IB10	IB9	IB8	IB7	IB6	IB5	IB4	IB3	IB2	IB1	IB0
W	1	X	X	X	X	X	X	GPI O_C ON9	GPI O_C ON8	GPI O_C ON7	GPI O_C ON6	GPI O_C ON5	GPI O_C ON4	GPI O_C ON3	GPI O_C ON2	GPI O_C ON1	GPI O_C ON0

*67h Initial Value = XXXX_XX00_0000_0000

R/W	RS	IB15	IB14	IB13	IB12	IB11	IB10	IB9	IB8	IB7	IB6	IB5	IB4	IB3	IB2	IB1	IB0
W	1	X	X	X	X	X	X	GPC LR9	GPC LR8	GPC LR7	GPC LR6	GPC LR5	GPC LR4	GPC LR3	GPC LR2	GPC LR1	GPC LR0

*68h Initial Value = XXXX_XX00_0000_0000

R/W	RS	IB15	IB14	IB13	IB12	IB11	IB10	IB9	IB8	IB7	IB6	IB5	IB4	IB3	IB2	IB1	IB0
W	1	X	X	X	X	X	X	GPI O_E N9	GPI O_E N8	GPI O_E N7	GPI O_E N6	GPI O_E N5	GPI O_E N4	GPI O_E N3	GPI O_E N2	GPI O_E N1	GPI O_E N0

*69h Initial Value = XXXX_XX00_0000_0000

R/W	RS	IB15	IB14	IB13	IB12	IB11	IB10	IB9	IB8	IB7	IB6	IB5	IB4	IB3	IB2	IB1	IB0
W	1	X	X	X	X	X	X	GPP OL9	GPP OL8	GPP OL7	GPP OL6	GPP OL5	GPP OL4	GPP OL3	GPP OL2	GPP OL1	GPP OL0

*6Ah Initial Value = XXXX_XX11_1111_1111

7.2.38.1. GPIO

When GPIO is input mode, GPIO value is set to the register.

When GPIO is output mode, GPIO register value is output to GPIO PAD.

7.2.38.2. GPIO_CON

Control of GPIO

When GPIO_CON is "0", then GPIO is input mode, and when "1", then GPIO is output mode

7.2.38.3. GPCLR

When GPIO is input mode, GPCLR clears specified GPIO interrupt (set by GPIO PAD input).

7.2.38.4. GPIO_EN

When GPIO is input mode, if GPIO_EN is “1”, it acts as enable internal interrupt.

7.2.38.5. GPPOL

If the bit is set to “1”, GPIO interrupt happens at rising edge of GPIO, If set to “0”, it happens at falling edge.

For more information about these registers, refer to GPIO Control section.

7.2.39. Gamma Control (R70h to R78h)

R/W	RS	IB15	IB14	IB13	IB12	IB11	IB10	IB9	IB8	IB7	IB6	IB5	IB4	IB3	IB2	IB1	IB0
W	1	X	X	CR5 6	CR5 5	CR5 4	CR5 3	CR5 2	CR5 1	CR5 0	X	X	X	CR0 3	CR0 2	CR0 1	CR0 0
W	1	X	X	CG5 6	CG5 5	CG5 4	CG5 3	CG5 2	CG5 1	CG5 0	X	X	X	CG0 3	CG0 2	CG0 1	CG0 0
W	1	X	X	CB5 6	CB5 5	CB5 4	CB5 3	CB5 2	CB5 1	CB5 0	X	X	X	CB0 3	CB0 2	CB0 1	CB0 0
W	1	X	X	CR1 5	CR1 4	CR1 3	CR1 2	CR1 1	CR1 0	X	X	CR2 5	CR2 4	CR2 3	CR2 2	CR2 1	CR2 0
W	1	X	X	CR3 5	CR3 4	CR3 3	CR3 2	CR3 1	CR3 0	X	X	CR4 5	CR4 4	CR4 3	CR4 2	CR4 1	CR4 0
W	1	X	X	CG1 5	CG1 4	CG1 3	CG1 2	CG1 1	CG1 0	X	X	CG2 5	CG2 4	CG2 3	CG2 2	CG2 1	CG2 0
W	1	X	X	CG3 5	CG3 4	CG3 3	CG3 2	CG3 1	CG3 0	X	X	CG4 5	CG4 4	CG4 3	CG4 2	CG4 1	CG4 0
W	1	X	X	CB1 5	CB1 4	CB1 3	CB1 2	CB1 1	CB1 0	X	X	CB2 5	CB2 4	CB2 3	CB2 2	CB2 1	CB2 0
W	1	X	X	CB3 5	CB3 4	CB3 3	CB3 2	CB3 1	CB3 0	X	X	CB4 5	CB4 4	CB4 3	CB4 2	CB4 1	CB4 0

These registers set the gamma set.

CR5[6:0]: The amplitude adjust register

CR4[4:0]: The amplitude adjust register

CR3[4:0]: The amplitude adjust register

CR2[4:0]: The amplitude adjust register

CR1[4:0]: The amplitude adjust register

CR0[3:0]: The amplitude adjust register

CG5[6:0]: The amplitude adjust register

CG4[4:0]: The amplitude adjust register

CG3[4:0]: The amplitude adjust register

CG2[4:0]: The amplitude adjust register

CG1[4:0]: The amplitude adjust register

CG0[3:0]: The amplitude adjust register

CB5[6:0]: The amplitude adjust register

CB4[4:0]: The amplitude adjust register

CB3[4:0]: The amplitude adjust register

CB2[4:0]: The amplitude adjust register

CB1[4:0]: The amplitude adjust register

CB0[3:0]: The amplitude adjust register

For more information, refer to the R, G, B Independent Gamma Adjustmetn Function.

7.2.40. EL Control (RF4h)

R/W	RS	IB15	IB14	IB13	IB12	IB11	IB10	IB9	IB8	IB7	IB6	IB5	IB4	IB3	IB2	IB1	IB0
W	1	X	X	X	X	X	X	X	X	X	X	EL_TEST	EL_ON	X	X	X	X

*66h Initial Value = XXXX _XXXX_XX10_XXXX

7.2.40.1. EL_TEST

EL_TEST selects manual EL_ON register.

EL_TEST must be set to "1".

7.2.40.2. EL_ON

EL_ON controls ELVDD power.

8. Reset Function

The S6E63D6 is initialized internally by RESET input. The reset input should be held 'L' for at least 10us. Do not access the GRAM nor initially set the instructions until the R-C oscillation frequency is stable after power has been supplied (10 ms).

8.1. Instruction Set Initialization

1. Display duty control (R01h) : FP3_0=1000, BP3_0=1000, NL5_0=10_1000
2. RGB interface control (R02h) : RM=0, DM=0, RIM1_0=00, VSPL=0, HSPL=0, EPL=0, DPL=0
3. Entry mode (R03h) : CLS=1, MDT1_0=00, BGR=0, SS=0, ID1_0=11, AM=0
4. Clock control (R04h) : DCR1_0=00
5. Display control 1 (R05h) : DISP_ON=0
6. Display control 2 (R06h) : CL=0, TEMON=0, REV=0
7. Panel interface control 1 (R07h) : CLWEA4_0=1_0010
8. Panel interface control 2 (R08h) : CLWEB4_0=1_0010, CLWEC4_0=1_0010
9. Panel interface control 3 (R09h) : SHE2_0=010, CLTE2_0=010
10. Stand by (R10h) : NAP=0, STB=1
11. Power gen 1 (R12h) : VC3_0=1000
12. Power gen 2 (R13h) : VINT3_0=0101
13. Power gen 3 (RF8h) : VGH4_0=1_0100
14. Power gen 4 (RF9h) : VGL4_0=1_0100
15. Power booster control (R14h) : DC22_0=100, DC12_0=010, BT1_0=10
16. Oscillator control (R18h) : RADJ5_0=01_1111
17. Source driver control (R1Ah) : GAMMA_TEST=0, SDUM_ON=0, SAP2_0=101
18. GRAM address set (R20h) : AD7_0=0000_0000, AD16_8=0_0000_0000
19. Vertical scroll control 1 (R30h, R31h) : SSA8_0=0_0000_0000, SEA8_0=1_0011_1111
20. Vertical scroll control 2 (R32h) : SST8_0=0_0000_0000
21. Partial screen driving position (R33h, R34h) : SS18_0=0_0000_0000, SE18_0=1_0011_1111
22. Vertical RAM address position (R35h, R36h) : VSA8_0=0_0000_0000, VEA8_0=1_0011_1111
23. Horizontal RAM address position (R37h) : HAS7_0=0000_0000, HEA7_0=1110_1111
24. Client initiated wake up (R38h) : VWAKE_EN=0
25. MDDI link wake up start position (R39h) : WKL8_0=0_0000_0000, WKF3_0=0000
26. Sub panel control 1(R3Ah, R3Bh) : SUB_SEL7_0=0111_1010, SUB_WR7_0=0010_0010
27. Sub panel control 2 (R3Ch) : FCV_EN=0, MPU_MODE=0, STN_EN=0, SUB_IM1_0=01
28. MTP control (R61h) : MTP_WRB=1, MTP_SEL=1, MTP_ERB=1
29. MTP register setting (R62h, 63h, 64h, 65h) : R21_BT2_0=000, R63_BT3_0=0000, G21_BT2_0=000, G63_BT3_0=0000, B21_BT2_0=000, B63_BT3_0=0000, E_OST2_0=000
30. GPIO control (R66h, R67h, R68h, R69h, R6Ah) : GPIO9_0=00_0000_0000, GPIO_CON9_0=00_0000_0000, GPCLR9_0=00_0000_0000, GPIO_EN9_0=00_0000_0000, GPPOL9_0=11_1111_1111
31. EL_ON (RF4h) : EL_TEST=1, EL_ON=0

9. Power Supply

9.1. Pattern Diagrams for Voltage Setting

The following figure shows a pattern diagram for the voltage setting and an example of waveforms.

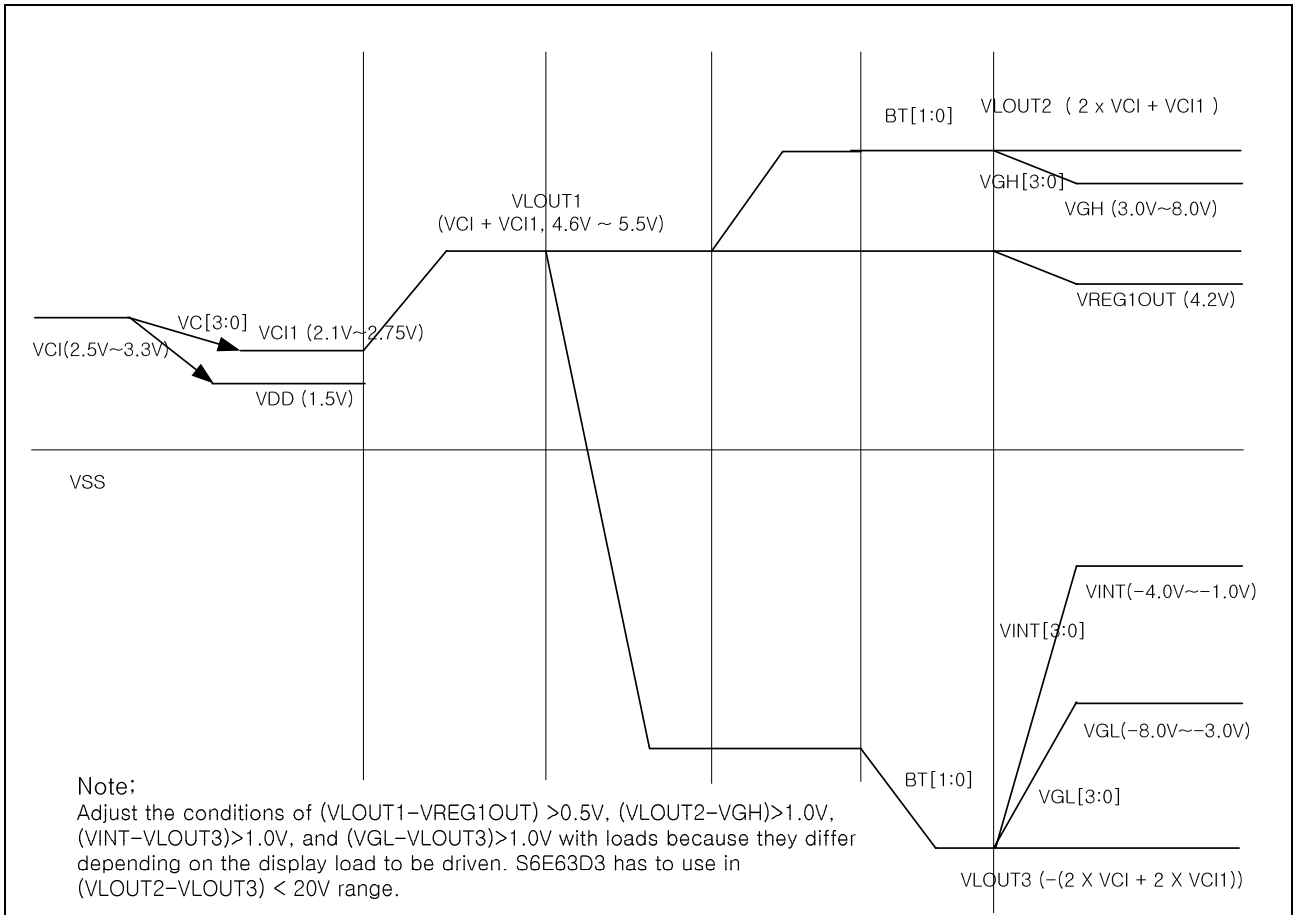

Figure 16. Pattern Diagram for Voltage Setting

9.2. Voltage Regulation Function

The S6E63D6 has the internal voltage regulator. By the use of this function, unexpected damages on internal logic circuit can be avoided. Furthermore, power consumption can also be obtained. Detailed function description and application configuration is described in the following diagram.

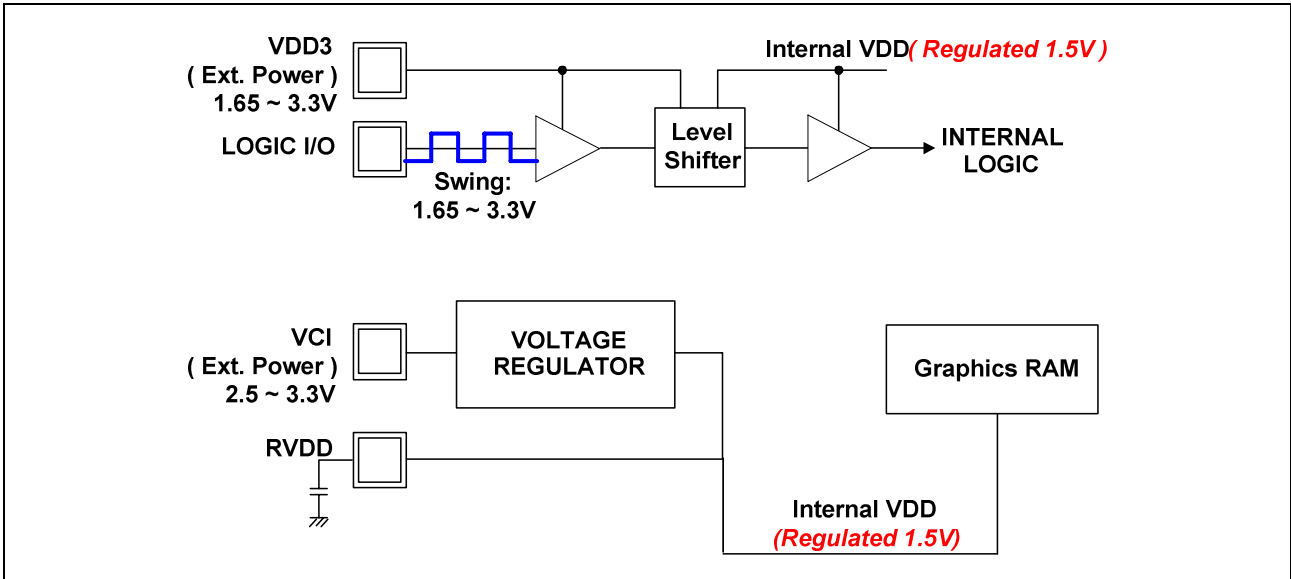

Figure 17. Voltage Regulation Function

10. Interface Specification

The S6E63D6 incorporates a system interface, which is used to set instructions, and an external display interface, which is used to display motion pictures, and a MDDI, which is high speed serial interface. Selecting these interfaces to match the screen data (motion picture or still picture) enables efficient transfer of data for display.

The external display interface includes RGB interface. This allows flicker-free screen update. When RGB interface is selected, the synchronization signals (VSYNC, HSYNC, and DOTCLK) are available for use in operating the display. The display data (DB17-0) is written according to the values of the data enable signal (ENABLE) in synchronization with the VSYNC, HSYNC, and DOTCLK signals. In addition, using the window address function enables rewriting only to the internal RAM area to display motion pictures. Using this function also enables simultaneously display of the motion picture area and the RAM data that was written.

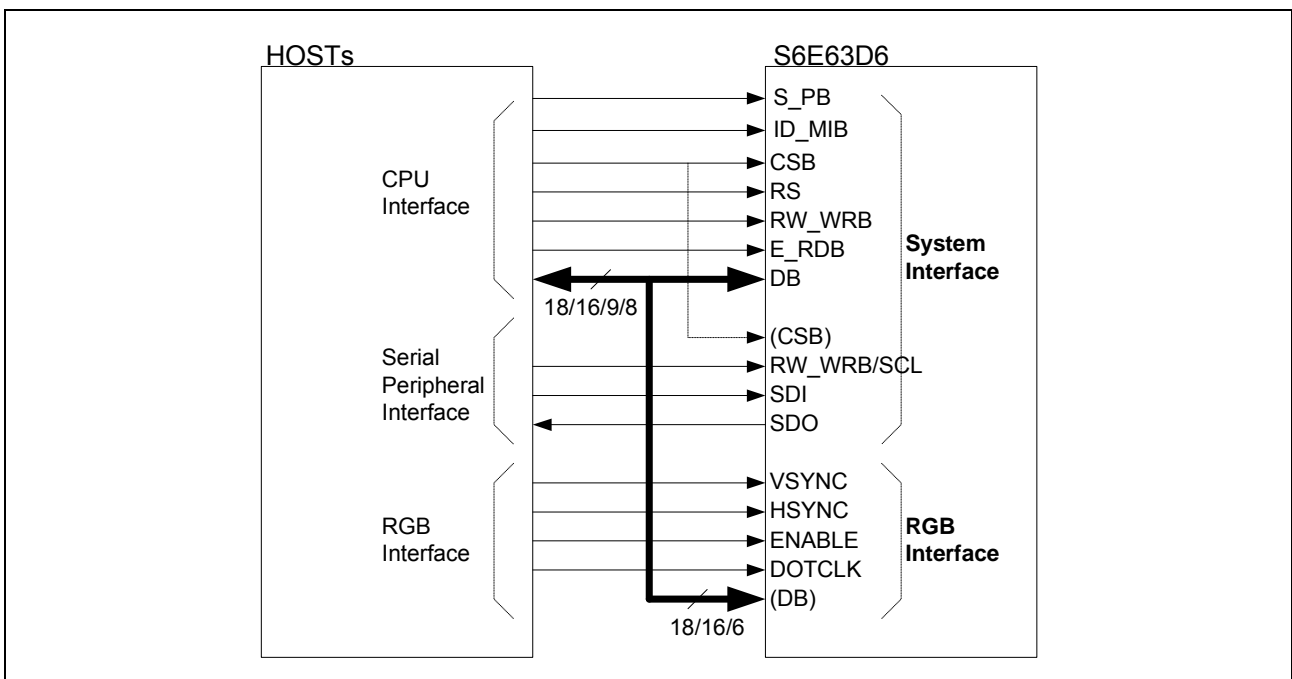

Figure 18. System Interface and RGB Interface

10.1. System Interface

S6E63D6 is enabling to set instruction and access to RAM by selecting S_PB, ID_MIB pads and Instruction in the system interface mode.

Table 60. System Interface Mode

Pads			Registers				Description			
MDDI_EN	S_PB	ID_MIB	Index Address	Command (CLS)	Command MDT[1]	Command MDT[0]				
0	0 (Parallel)	0 (80 mode)	Default & 24h (9/8bit)	0 (80 8bit)	0	X	80-system 8-bit 65k bus interface			
					1	0	80-system 8-bit 260k bus interface			
					1	X	80-system 8-bit 65k bus interface			
				1 (80 9bit)	X	X	80-system 9-bit 260k bus interface			
			Index 23h (18/16bit)	0 (80 16bit)	0	0	80-system 16-bit 65k bus interface			
					1	X	80-system 16-bit 260k bus interface			
				1 (80 18bit)	X	X	80-system 18-bit 260k bus interface			
				1 (68 mode)	1 (68 mode)	Default & 24h (9/8bit)	0 (68 8bit)	0	X	68-system 8-bit 65k bus interface
								1	0	68-system 8-bit 260k bus interface
	Index 23h (18/16bit)	0 (68 16bit)	0			0	68-system 16-bit 65k bus interface			
			1			X	68-system 16-bit 260k bus interface			
	1 (68 18bit)	X	X	68-system 18-bit 260k bus interface						
1 (Serial)	ID	X	X	X	X	Serial peripheral interface (SPI)				
1	X		X	X	X	MDDI				

Note

1. For details, see the Entry Mode (R03h)

We can select system interface mode by pads and instruction, don't care 8-/16-bit bus system after power on.

1. In case of 8/9-bit bus system.

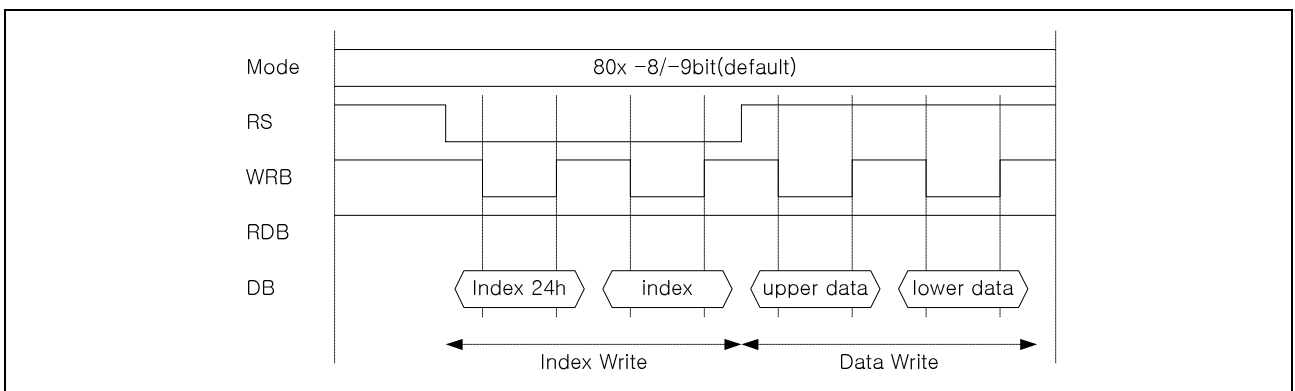

Figure 19. 8/9-bit Bus System

2. In case of 18/16-bit bus system.

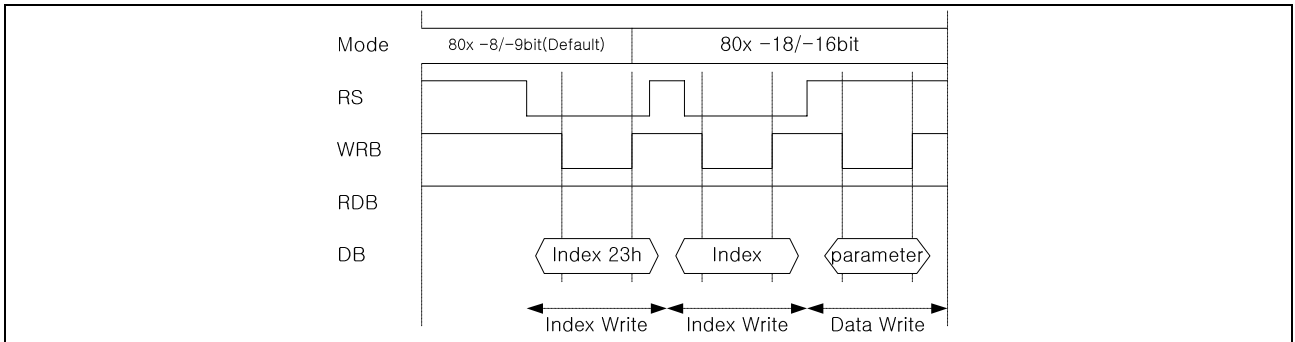

Figure 20. 18/16-bit Bus System

10.1.1. 68-system 18-bit Bus Interface

10.1.1.1. Bit Assignment

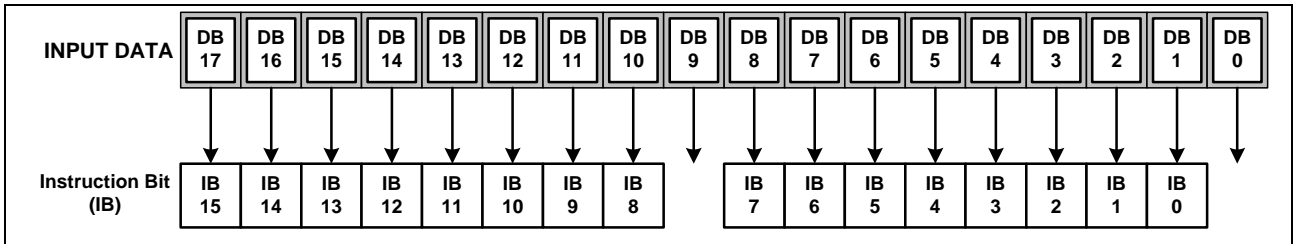

Figure 21. Instruction Format for 68-system 18-bit Interface

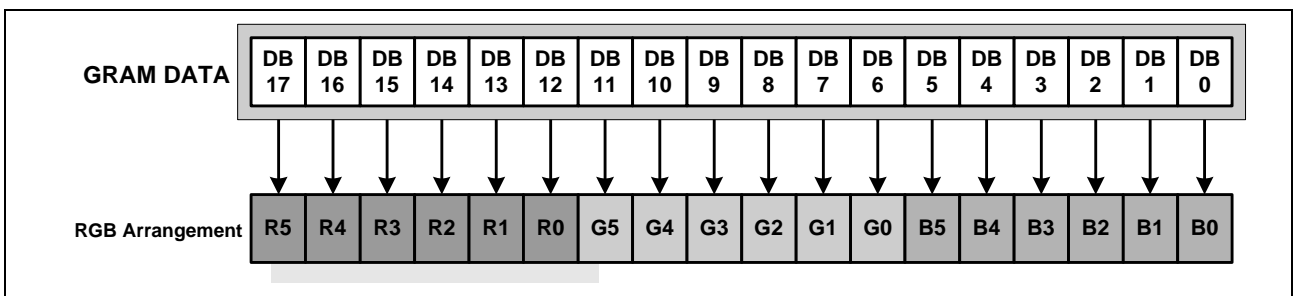

Figure 22. RAM Data Write Format for 68-system 18-bit Interface

10.1.1.2. Timing Diagram

There are 4 timing conditions for 68-system 18-bit CPU interface, which are index write timing condition, data write timing condition, data read timing condition and status read timing condition.

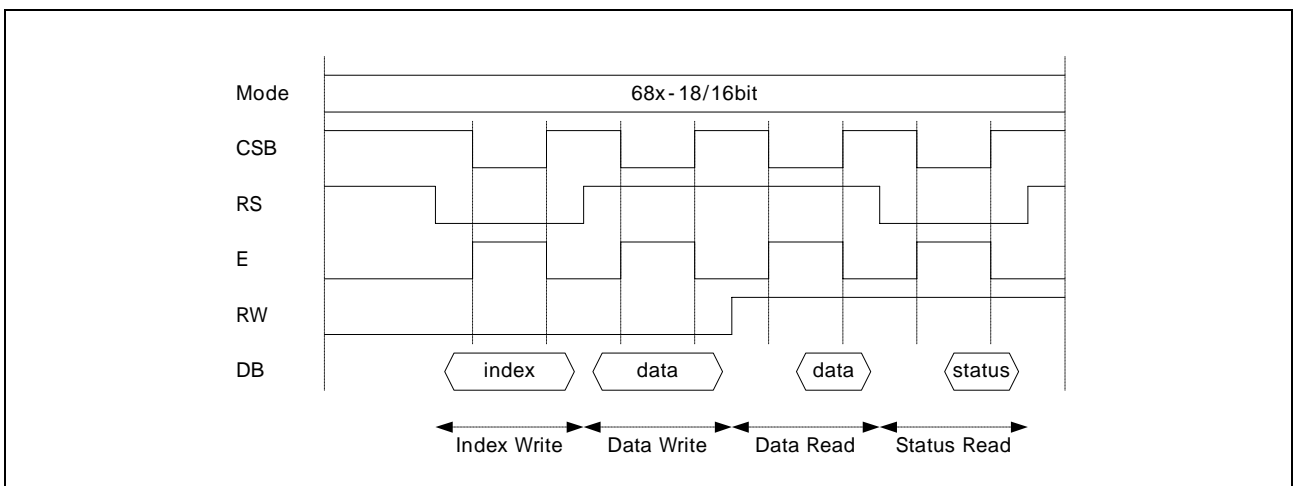

Figure 23. Timing Diagram of 68-system 18-bit Bus Interface

10.1.2. 68-system 16-bit Bus Interface

10.1.2.1. Bit Assignment

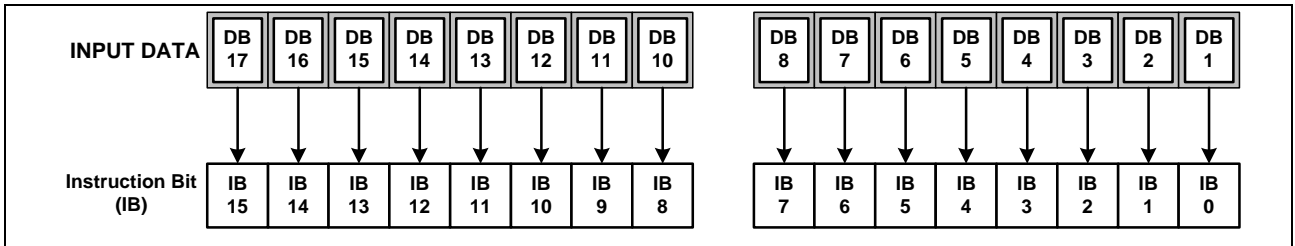

Figure 24. Instruction Format for 68-system 16-bit Interface

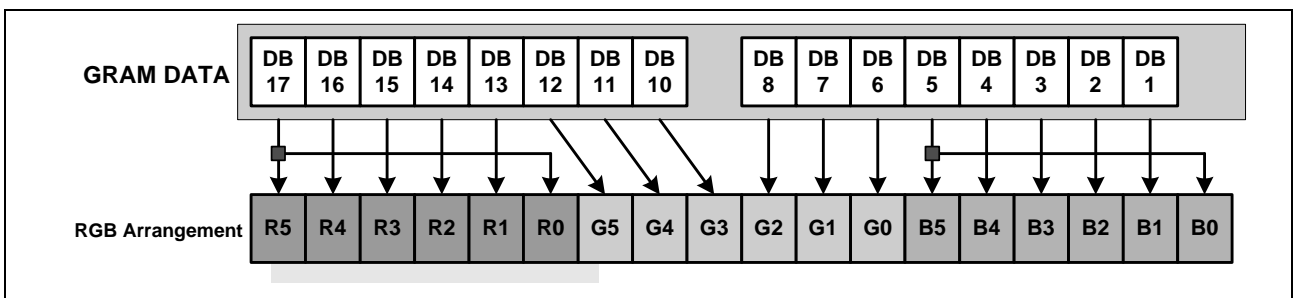

Figure 25. RAM Data Write Format for 68-system 16-bit Interface

10.1.2.2. Timing Diagram

There are 4 timing conditions for 68-system 16-bit CPU interface, which are index write timing condition, data write timing condition, data read timing condition and status read timing condition.

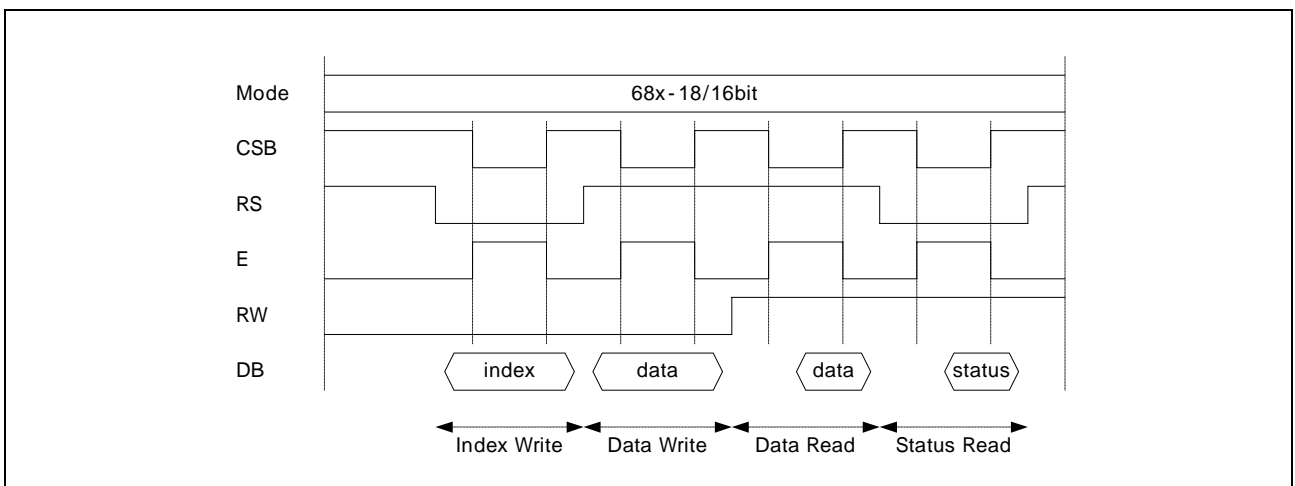

Figure 26. Timing Diagram of 68-system 16-bit Bus Interface

10.1.3. 68-system 9-bit Bus Interface

10.1.3.1. Bit Assignment

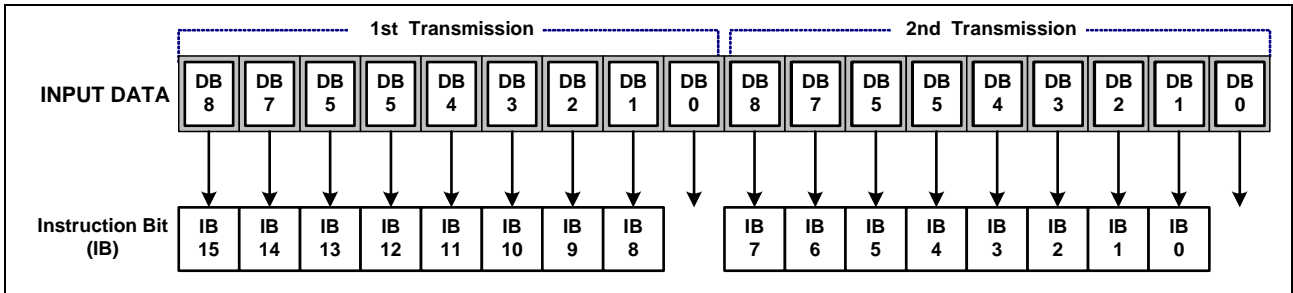

Figure 27. Instruction Format for 68-system 9-bit Interface

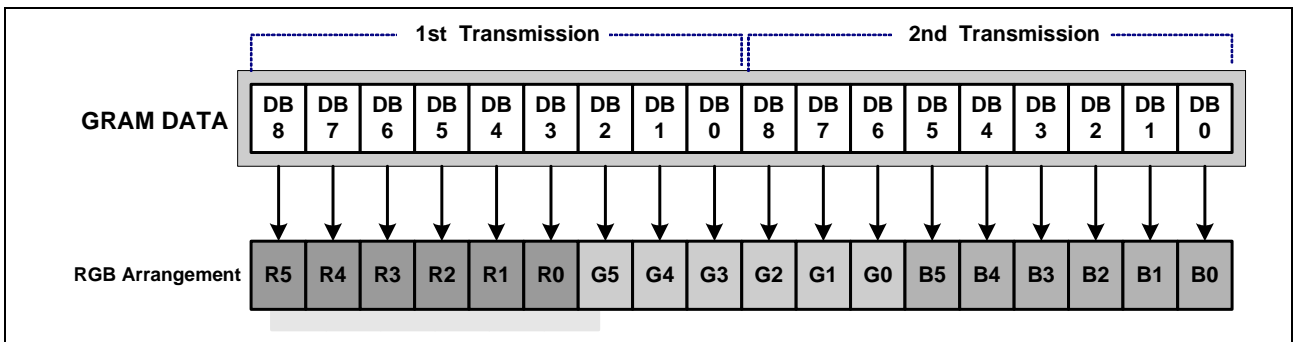

Figure 28. RAM Data Write Format for 68-system 9-bit Interface

10.1.3.2. Timing Diagram

There are 4 timing conditions for 68-system 9-bit CPU interface, which are index write timing condition, data write timing condition, data read timing condition and status read timing condition. In this mode, 16-bit instructions and GRAM data are divided into two half words and the transfer starts from the upper half word. Note that the upper byte must also be written when the index register is written.

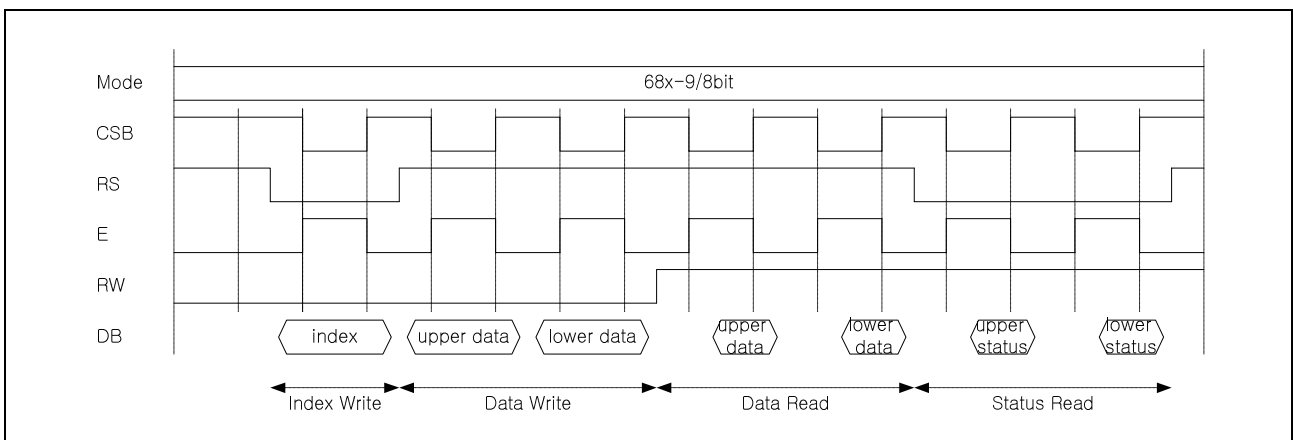

Figure 29. Timing Diagram of 68-system 9-bit Bus Interface

10.1.4. 68-system 8-bit Bus Interface

10.1.4.1. Bit Assignment

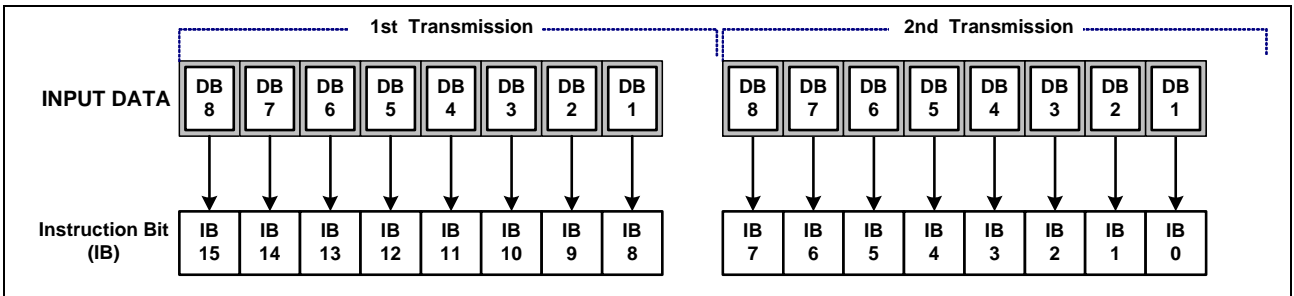

Figure 30. Instruction Format for 68-system 8-bit Interface

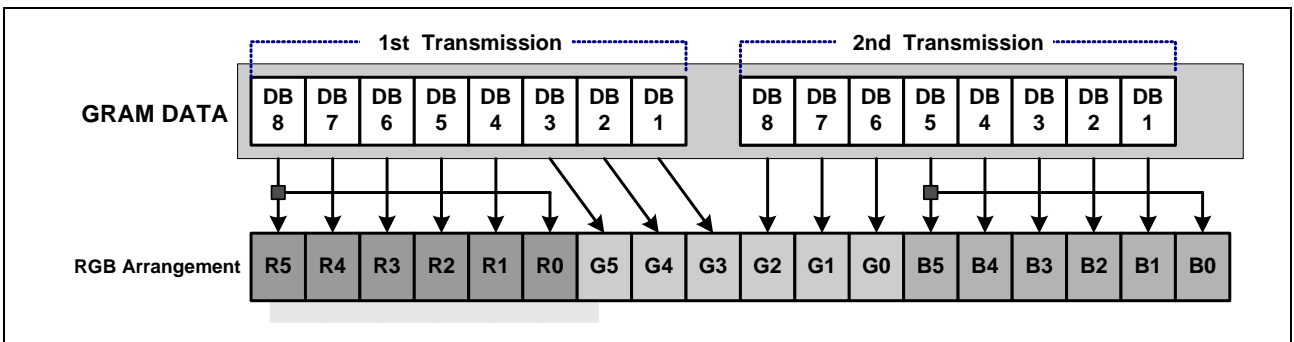

Figure 31. RAM Data Write Format for 68-system 8-bit Interface

10.1.4.2. Timing Diagram

There are 4 timing conditions for 68-system 8-bit CPU interface, which are index write timing condition, data write timing condition, data read timing condition and status read timing condition. In this mode, 16-bit instructions and GRAM data are divided into two half words and the transfer starts from the upper half word. Note that the upper byte must also be written when the index register is written.

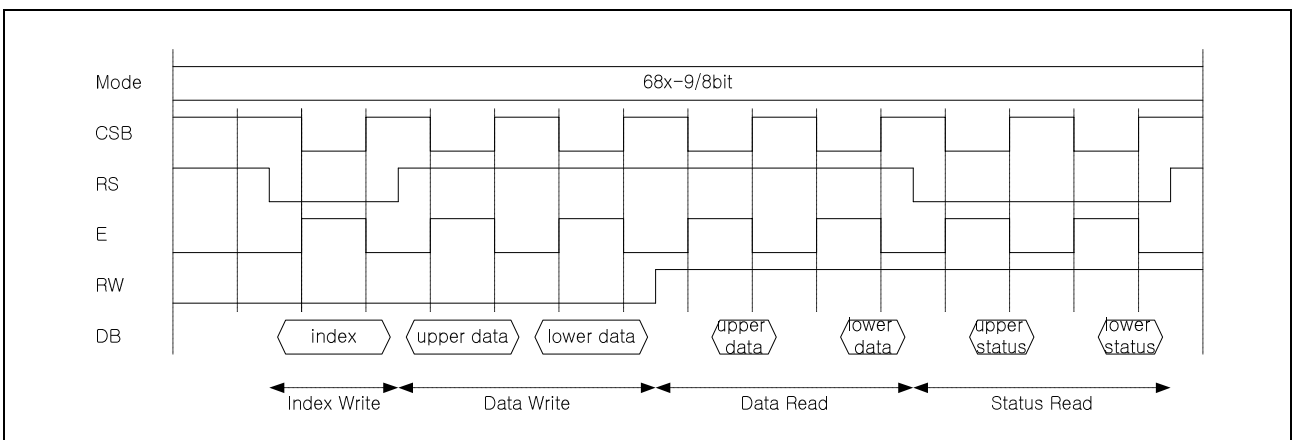

Figure 32. Timing Diagram of 68-System 8-Bit bus interface

10.1.5. 80-system 18-bit Bus Interface

10.1.5.1. Bit Assignment

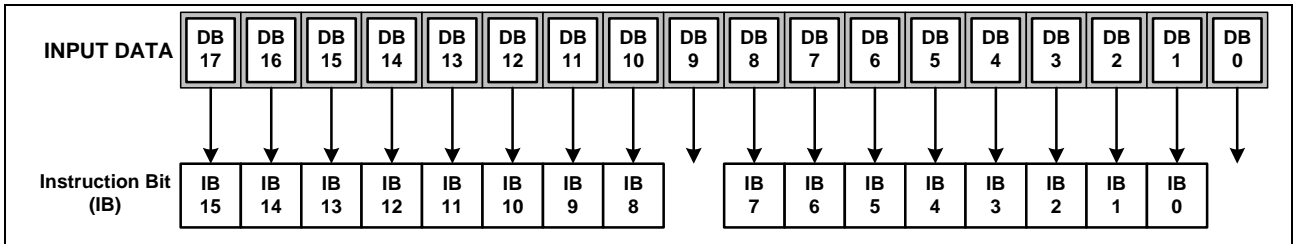

Figure 33. Instruction Format for 80-system 18-bit Interface

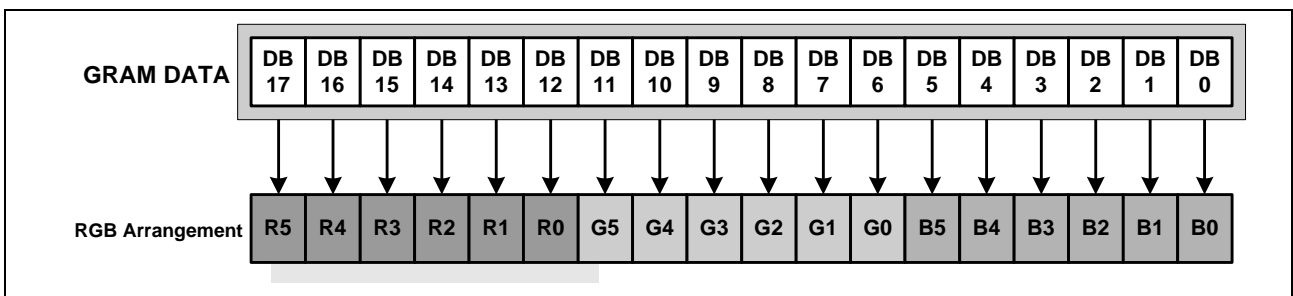

Figure 34. RAM Data Write Format for 80-system 18-bit Interface

10.1.5.2. Timing Diagram

There are 4 timing conditions for 80-system 18-bit CPU interface, which are index write timing condition, data write timing condition, data read timing condition and status read timing condition.

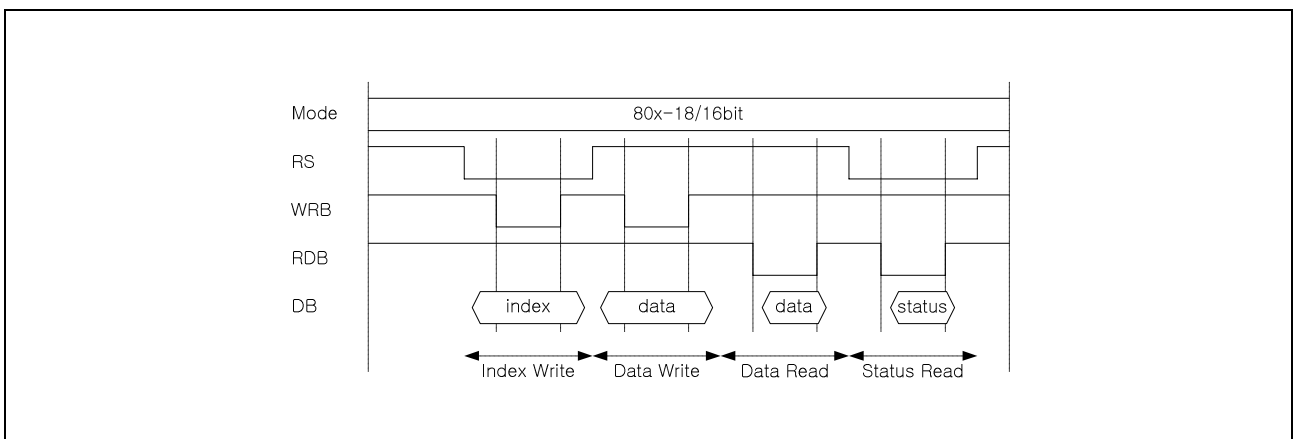

Figure 35. Timing Diagram of 80-system 18-bit Bus Interface

10.1.6. 80-system 16-bit Bus Interface

10.1.6.1. Bit Assignment

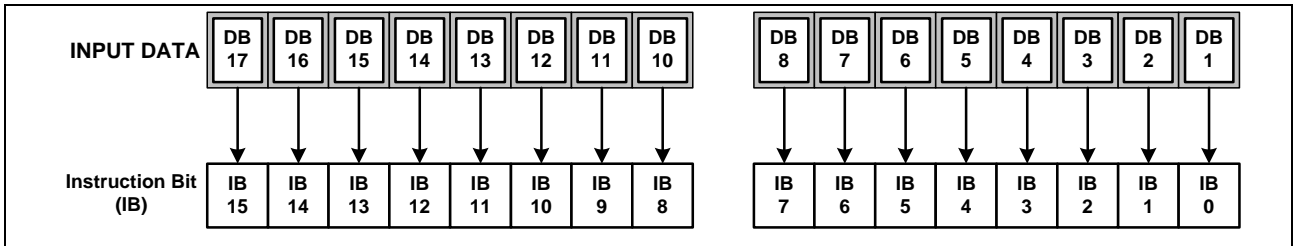

Figure 36. Instruction Format for 80-system 16-bit Interface

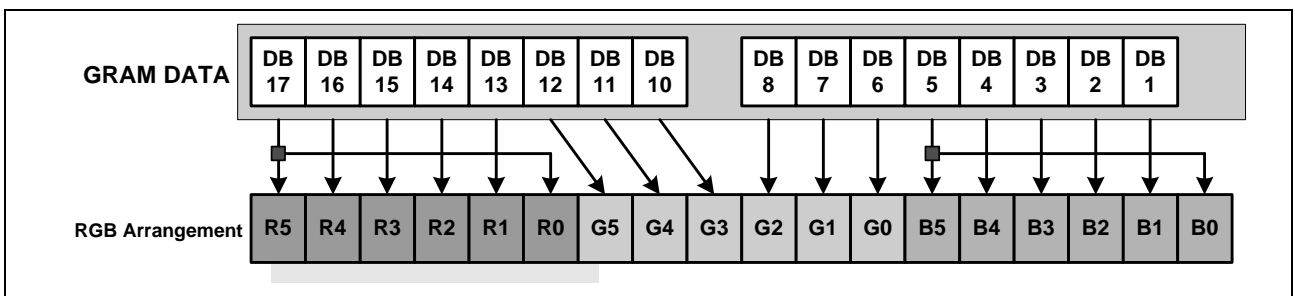

Figure 37. RAM Data Write Format for 80-system 16-bit Interface

10.1.6.2. Timing Diagram

There are 4 timing conditions for 80-system 16-bit CPU interface, which are index write timing condition, data write timing condition, data read timing condition and status read timing condition.

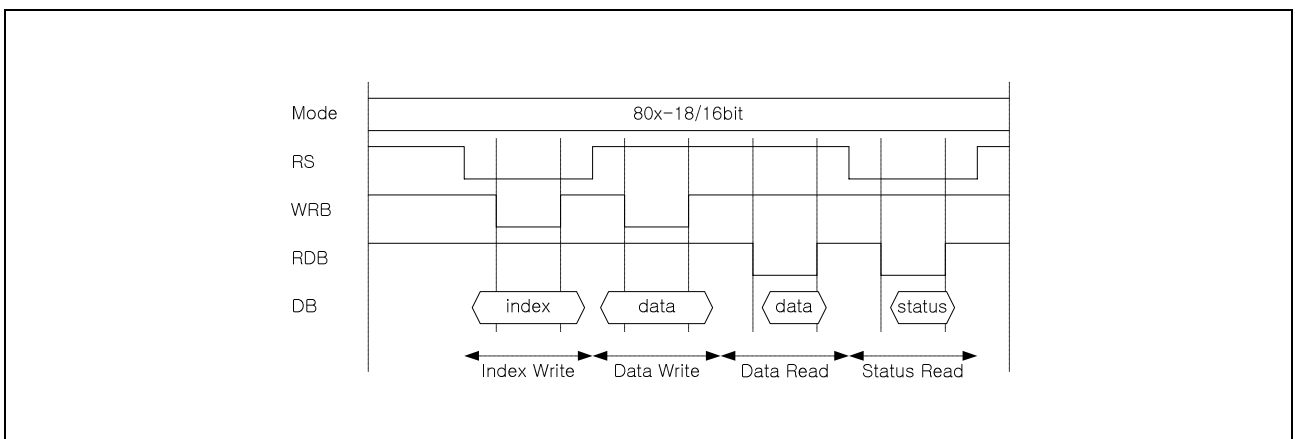

Figure 38. Timing Diagram of 80-system 16-bit Bus Interface

10.1.7. 80-system 9-bit Bus Interface

10.1.7.1. Bit Assignment

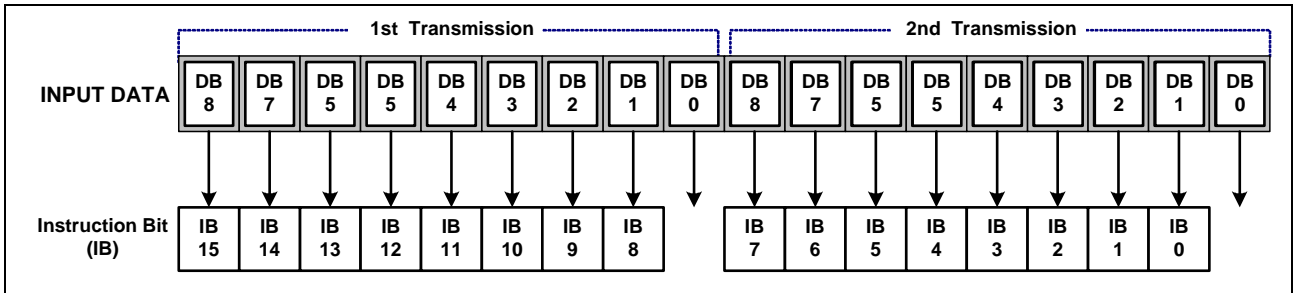

Figure 39. Instruction Format for 80-system 9-bit Interface

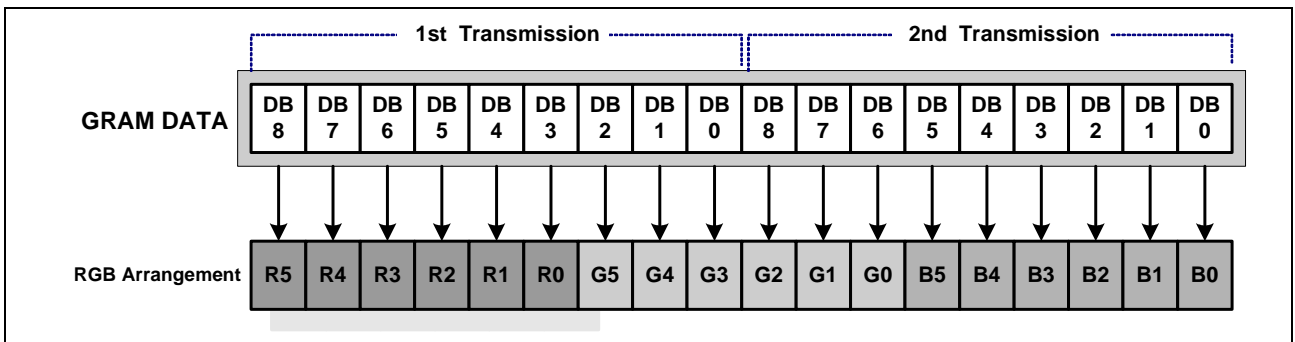

Figure 40. RAM Data Write Format for 80-system 9-bit Interface

10.1.7.2. Timing Diagram

There are 4 timing conditions for 80-system 9-bit CPU interface, which are index write timing condition, data write timing condition, data read timing condition and status read timing condition. In this mode, 16-bit instructions and GRAM data are divided into two half words and the transfer starts from the upper half word. Note that the upper byte must also be written when the index register is written.

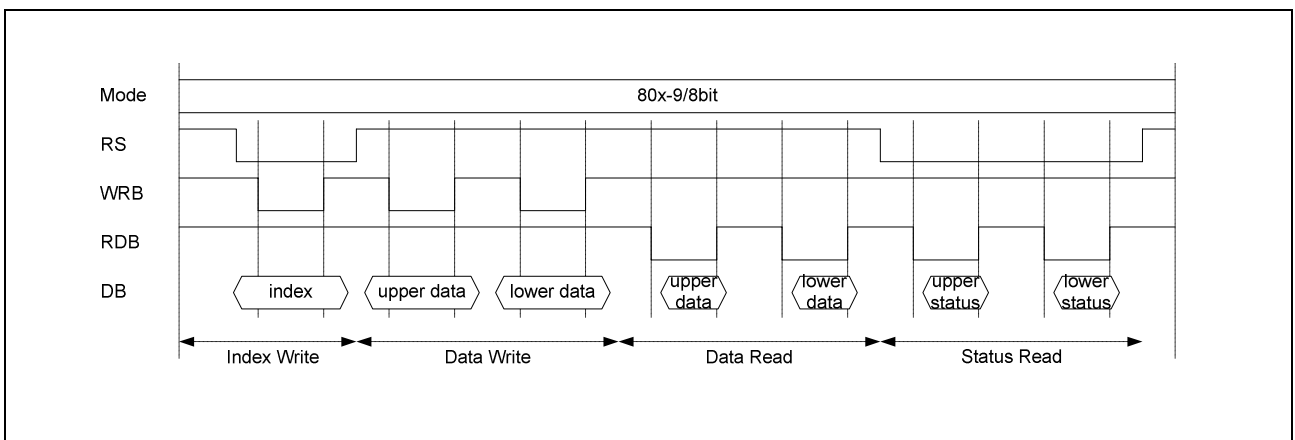

Figure 41. Timing Diagram of 80-system 9-bit Bus Interface

10.1.8. 80-system 8-bit Bus Interface

10.1.8.1. Bit Assignment

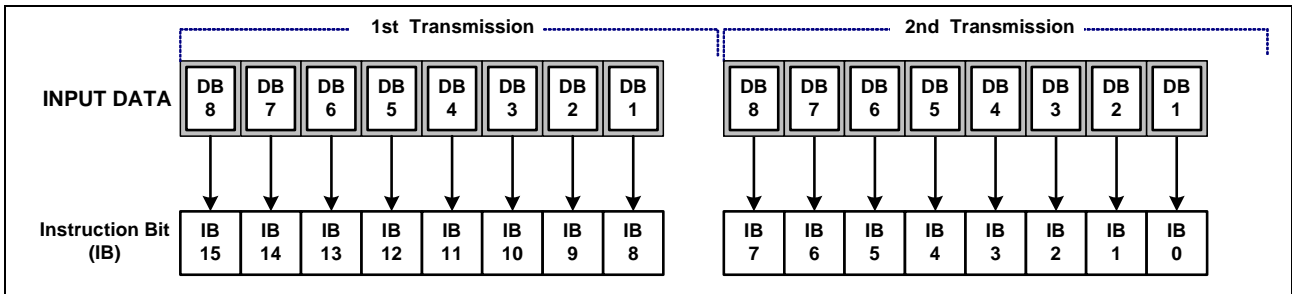

Figure 42. Instruction Format for 80-system 8-bit Interface

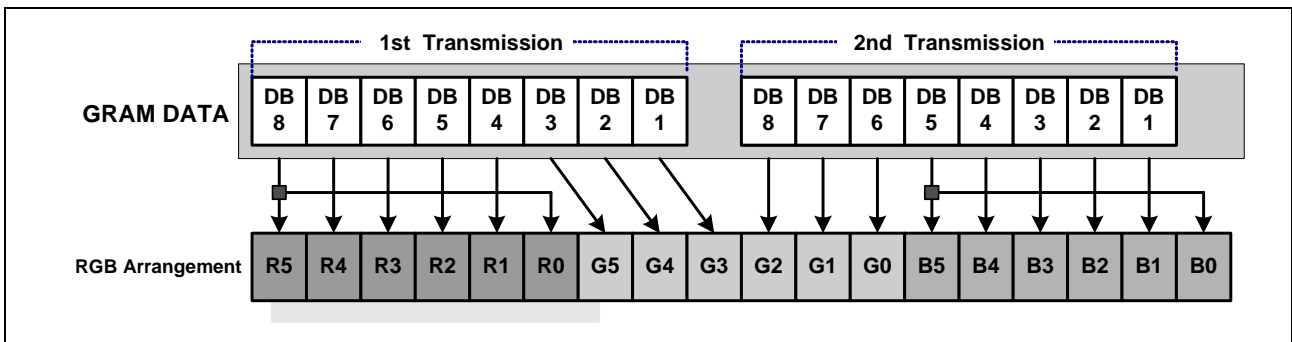

Figure 43. RAM Data Write Format for 80-system 8-bit Interface

10.1.8.2. Timing Diagram

There are 4 timing conditions for 80-system 8-bit CPU interface, which are index write timing condition, data write timing condition, data read timing condition and status read timing condition. In this mode, 16-bit instructions and GRAM data are divided into two half words and the transfer starts from the upper half word. Note that the upper byte must also be written when the index register is written.

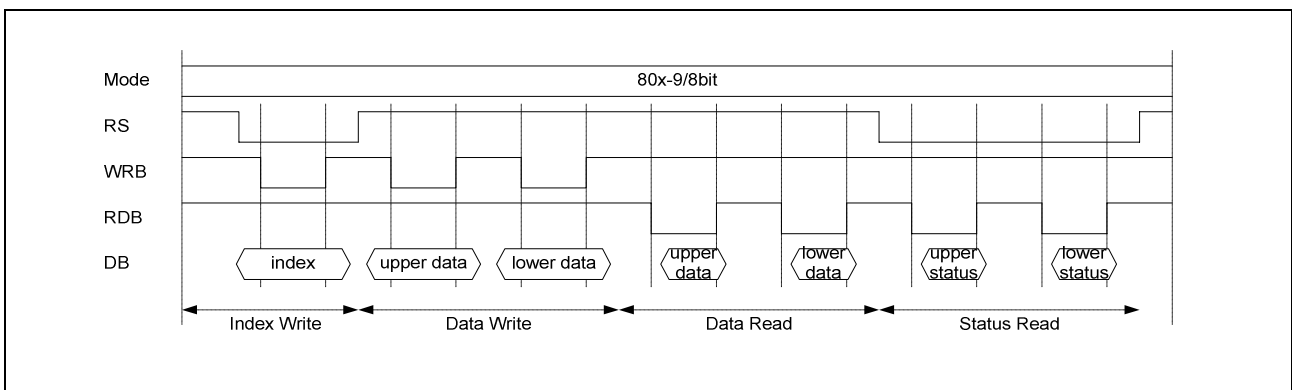

Figure 44. Timing Diagram of 80-System 8-Bit bus interface

10.1.9. 68-/80-system 8-/9-bit Interface Synchronization Function

The S6E63D6 supports the transfer synchronization function, which resets the upper/lower counter to count upper/lower 8-/9-bit data transfer in the 8-/9-bit bus interface. Noise causing transfer mismatch between the upper and lower bits can be corrected by a reset triggered by writing a "22h" instruction. The next transfer starts from the upper bits. Executing synchronization function periodically can recover any runaway in the display system.

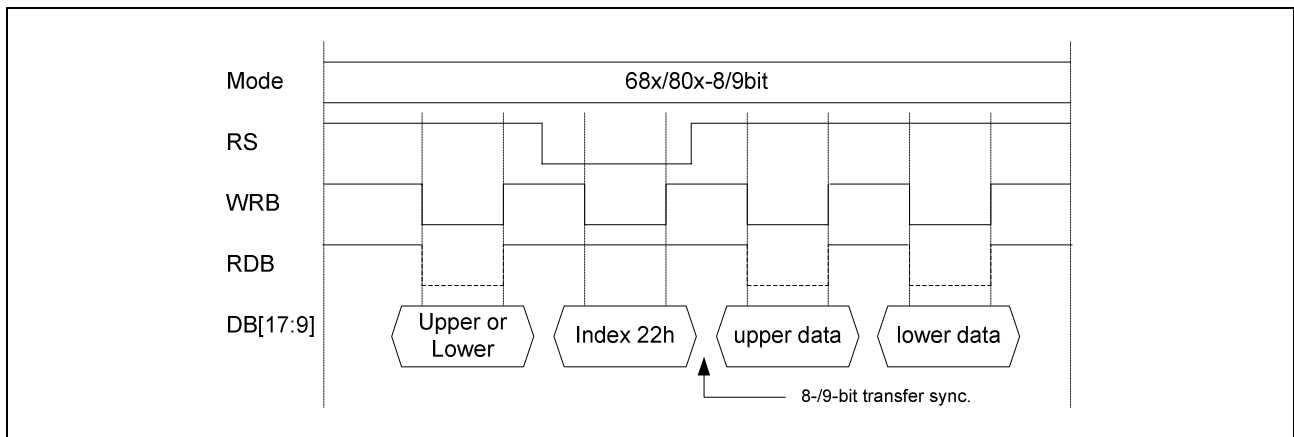

Figure 45. 8-/9-bit Interface Transfer Synchronization

10.1.10. Serial Peripheral Interface

Setting the S_PB pad to the VDD3 level allows serial peripheral interface (SPI) transfer, using the chip select line (CSB), serial transfer clock line (SCL), serial input data (SDI), and serial output data (SDO). For a serial interface, the ID bit is selected by the ID_MIB pad. If the chip is set up for serial interface, the DB17-0 pads are used only data bus of RGB Interface.

The S6E63D6 initiates serial data transfer by transferring the start byte at the falling edge of CSB input. It ends serial data transfer at the rising edge of CSB input.

The S6E63D6 is selected when the 6-bit chip address in the start byte matches the 6-bit device identification code that is assigned to the S6E63D6. When selected, the S6E63D6 receives the subsequent data string.

The least significant bit (LSB) of the identification code can be determined by the ID_MIB pad. The five upper bits must be 01110. Two different chip addresses must be assigned to a single S6E63D6 because the seventh bit of the start byte is used as a register select bit (RS). That is, when RS = 0, data can be written to the index register or status can be read, and when RS = 1, an instruction can be issued. Read or write operation is selected according to the eighth bit of the start byte (R/W bit). The data is received when the R/W bit is 0, and is transmitted when the R/W bit is 1.

After receiving the start byte, the S6E63D6 receives or transmits the subsequent data byte-by-byte. The data is transferred with the MSB first. All S6E63D6 instructions are 16 bits. Two bytes are received with the MSB first (DB15 to DB0), then the instructions are internally executed. After the start byte has been received, the first byte is fetched as the upper eight bits of the instruction and the second byte is fetched as the lower eight bits of the instruction.

Table 61. Start Byte Format on SPI

Transfer bit	S	1	2	3	4	5	6	7	8
Start byte format	Transfer start	Device ID code						RS	R/W
		0	1	1	1	0	ID		

Note

- 1. ID bit is selected by the ID_MIB pad.

Table 62. RS an R/W Bit Function on SPI

RS	R/W	Function
0	0	Set index register
0	1	Read status
1	0	Write register data (parameter)
1	1	Read register data (parameter)

10.1.10.1. Bit Assignment

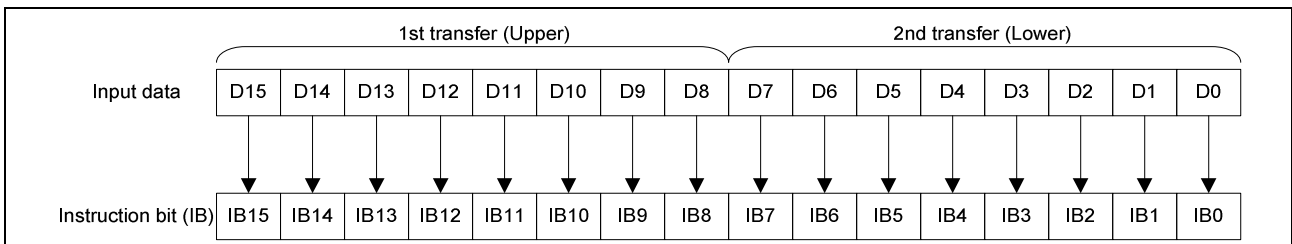

Figure 46. bit Assignment of Instructions on SPI

10.1.10.2. Timing Diagram

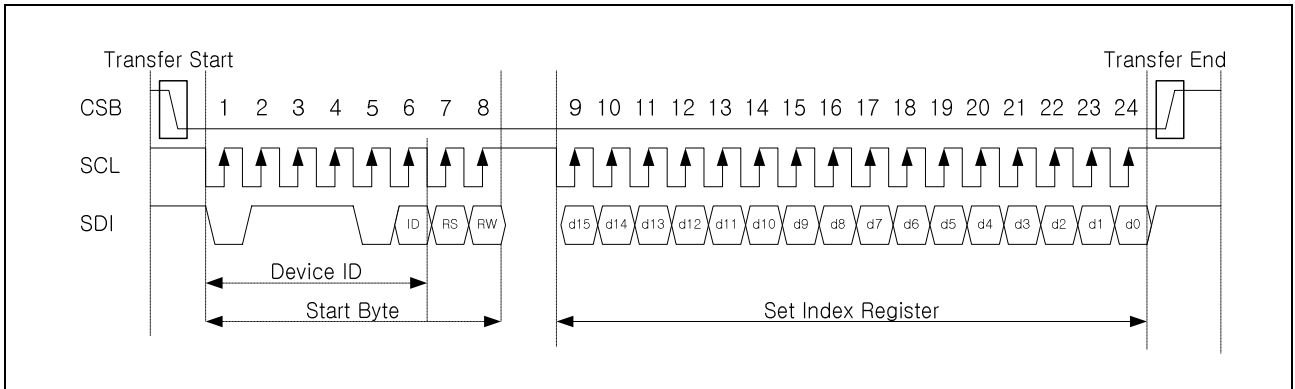

Figure 47. timing diagram of Index Register Set through SPI

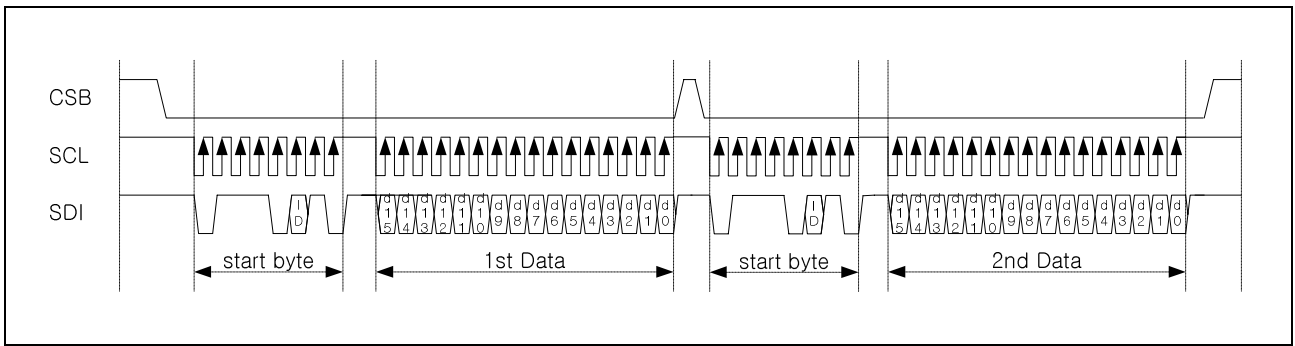

Figure 48. Timing Diagram of Consecutive Register Data-Write through SPI

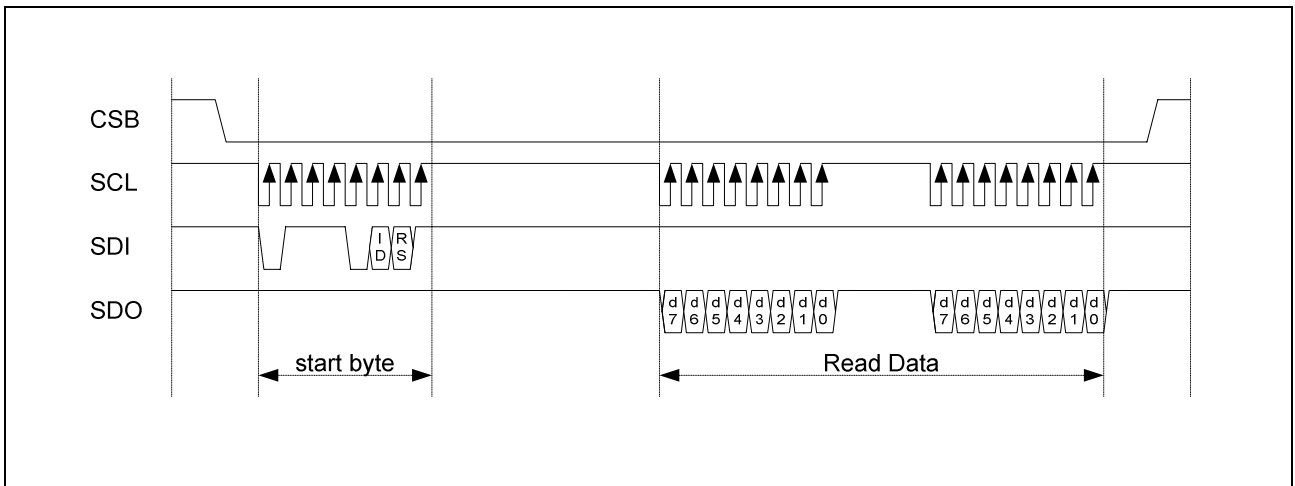

Figure 49. Timing Diagram of Register Read through SPI

10.1.11. Index and Parameter Recognition

If more parameter command is being sent, exceed parameters are ignored.

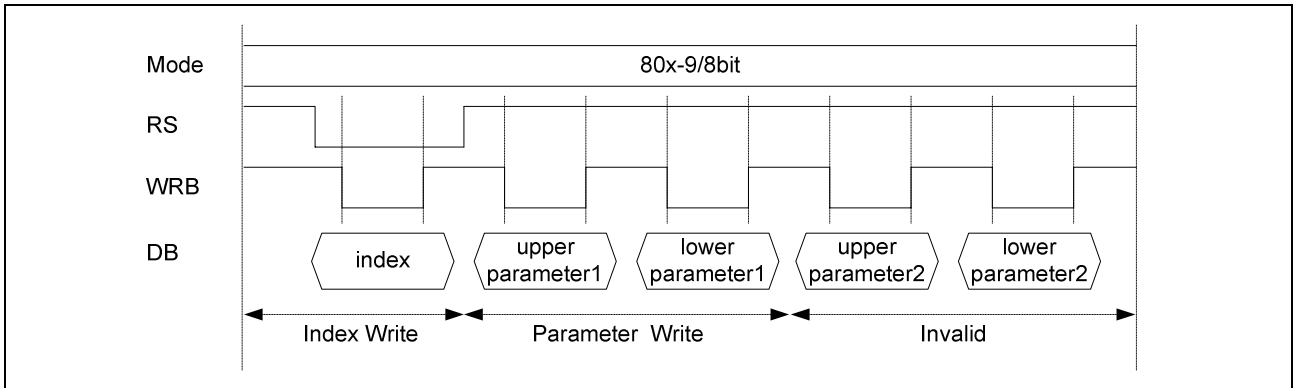

Figure 50. Index and Parameter Recognition with 8-/9-bit Interface

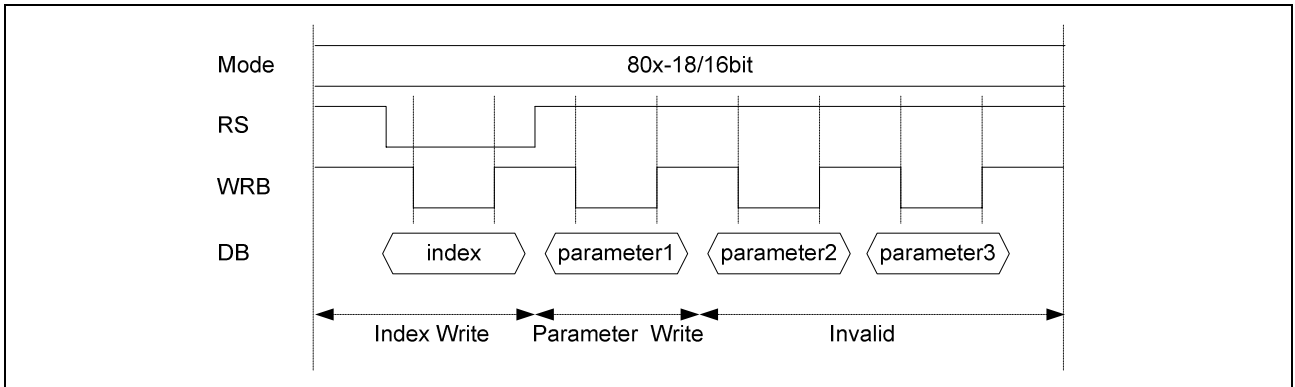

Figure 51. Index and Parameter Recognition with 18-/16-bit Interface

10.2. External Display Interface (RGB Interface)

The following interfaces are available as external display interface. It is determined by bit setting of RIM1-0. RAM accesses can be performed via the RGB interface.

Table 63. Relationship between RIM and RGB Interface

RIM1	RIM0	RGB Interface	DB Pads
0	0	18-bit RGB interface	DB17 to 0
0	1	16-bit RGB interface	DB17 to 10, DB8 to 1
1	0	6-bit RGB interface	DB8 to 3
1	1	Setting disable	

The relationship between EPL and ENABLE signals is shown below. When ENABLE is not active, the address is not updates. When ENABLE is active, the address is updated.

Table 64. Relationship between EPL and ENABLE

EPL	ENABLE	RAM Write	RAM Address
0	0	Valid	Update
0	1	Invalid	Hold
1	0	Invalid	Hold
1	1	Valid	Update

10.2.1. 18-bit RGB Interface

10.2.1.1. Bit Assignment

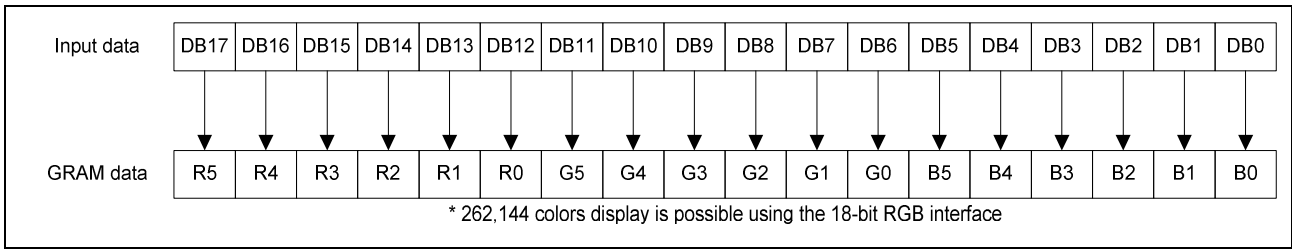

Figure 52. Bit Assignment of GRAM on 18-bit RGB Interface

10.2.2. 16-bit RGB Interface

10.2.2.1. Bit Assignment

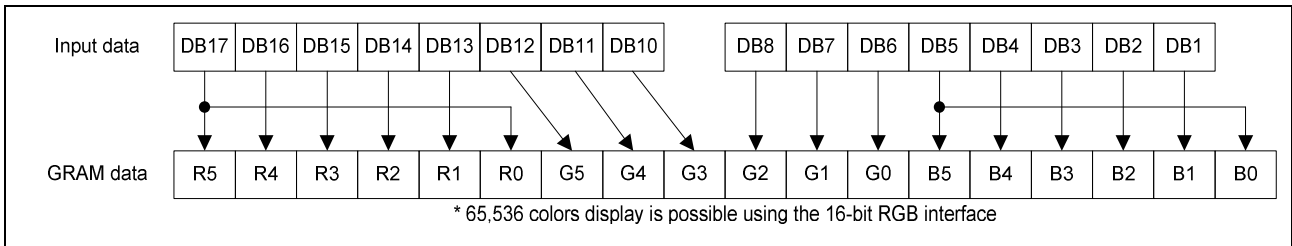

Figure 53. Bit Assignment of GRAM on 16-bit RGB Interface

10.2.2.2. Timing Diagram

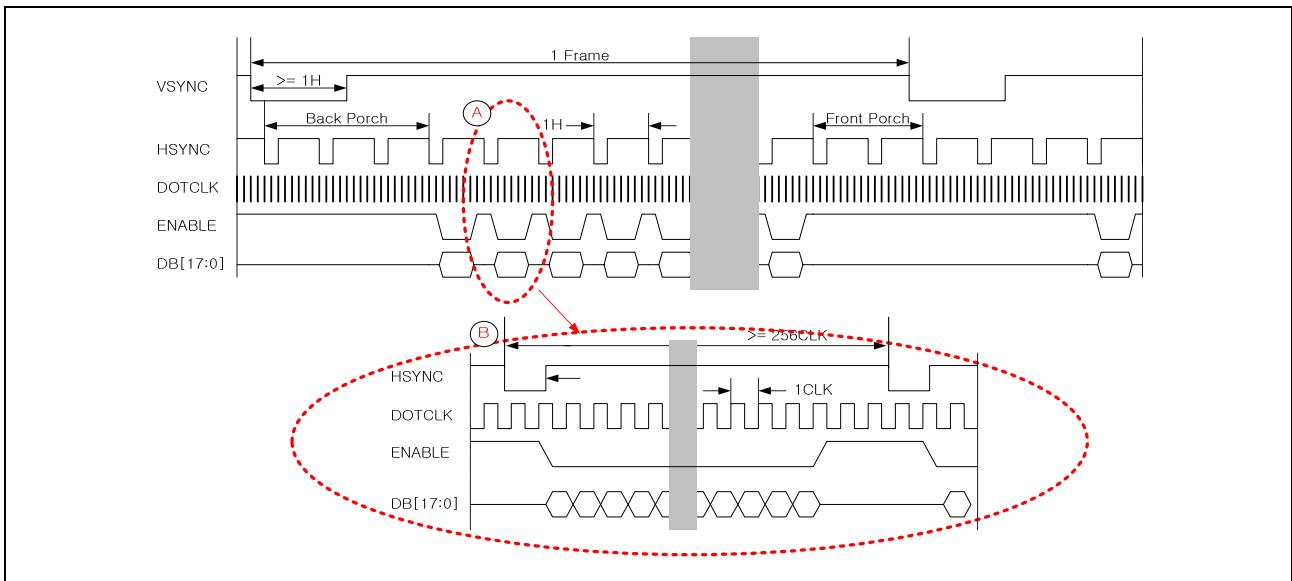

Figure 54. Timing Diagram of 18-/16-bit RGB Interface

Note

- 1. HSYNC Period must be $\geq 256 \text{ DOTCLK}$

10.2.3. 6-bit RGB Interface

In order to transfer data on 6bit RGB Interface there should be three transfers.

10.2.3.1. Bit Assignment

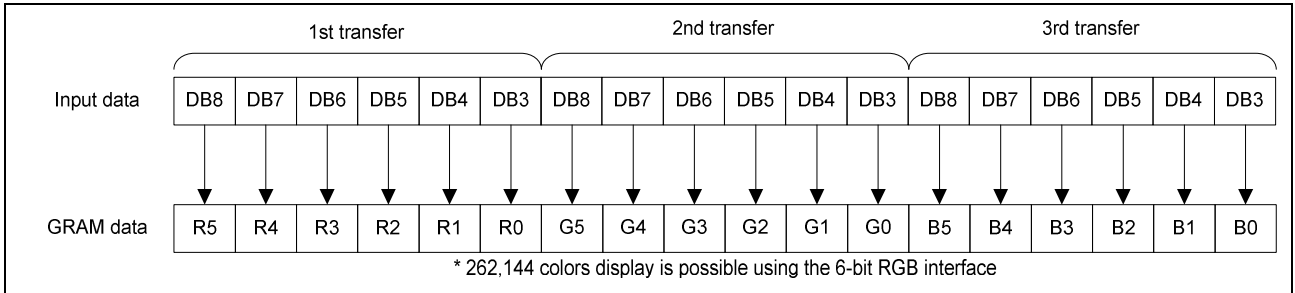

Figure 55. Bit Assignment of GRAM on 6-bit RGB Interface

10.2.3.2. Timing Diagram

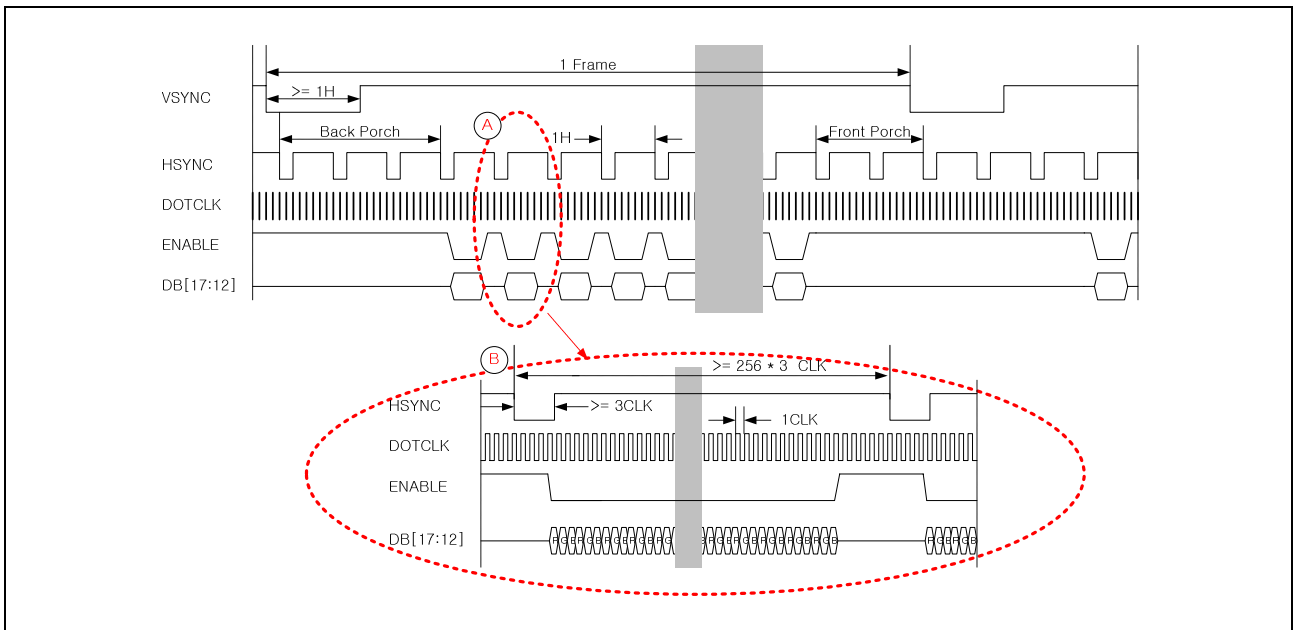

Figure 56. Timing Diagram of 6-bit RGB Interface

Note

1. Three clocks are regarded as one clock for transfer when data is transferred in 6-bit interface.
2. VSYNC, HSYNC, ENABLE, DOTCLK, and DB[8:3] should be transferred in units of three clocks.
3. HSYNC Period must be $\geq 256 * 3$ CLK

10.2.3.3. Transfer Synchronization on 6-bit RGB Interface

The figure shows transfer synchronization function for 6bit RGB interface. S6E63D6 has a transfer counter to count 1st, 2nd and 3rd data transfer of 6bit RGB Interface. The transfer counter is reset on the falling edge of HSYNC and enters the 1st data transmission state. Transfer mismatch can be corrected at every new transfer restarts with HSYNC signal. In this method, when data is consecutively transferred in such a way as displaying motion pictures, the effect of transfer mismatch will be reduced and recovered by normal operation.

The internal display is operated in units of three DOTCLKs. When DOTCLK is not input in units of pixels, clock mismatch occurs and the frame, which is operated, and the next frame are not displayed correctly

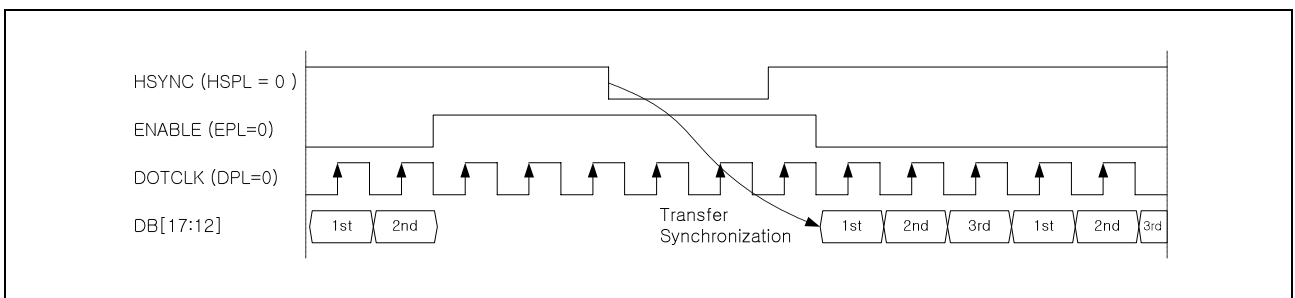

Figure 57. Transfer Synchronization Function on 6-bit RGB Interface mode

10.2.4. Usage on External Display Interface

1. When external display interface is in use, the following functions are not available.

Table 65. Display Function and External Display Interface

Function	External Display Interface	System Interface
Partial Display	Cannot be used	Can be used
Scroll Function	Cannot be used	Can be used
Rotation	Cannot be used	Can be used
Mirroring	Cannot be used	Can be used
Window Function	Cannot be used	Can be used

2. VSYNC, HSYNC, and DOTCLK signals should be supplied during display operation via RGB interface.

3. RGB data are transferred for three clock cycles in 6-bit RGB interface. Data transferred, therefore, should be transferred in units of RGB.

4. Interface signals, VSYNC, HSYNC, DOTCLK, ENABLE and DB17-0 should be set in units of RGB (pixels) to match RGB transfer.

5. Transitions between internal operation mode and external display interface should follow the mode transition sequence shown below.

6. During the period between the completion of displaying one frame data and the next VSYNC signal, the display will remain front porch period.

10.3. MDDI (Mobile Display Digital Interface)

10.3.1. Introduction of MDDI

The S6E63D6 supports MDDI. The MDDI is a differential & serial interface with high speed. Both command and image data transfer can be achieved with MDDI.

MDDI host & client are linked with Data and STB line. Through Data line, command or image data is transferred from MDDI host to MDDI client, and vice versa. Data is transferred by packet unit.

Through STB line, strobe signal is transferred. When the link is in “FORWARD direction”, data is transferred from host to client, in “REVERSE direction”, client transfer reverse data to MDDI host.

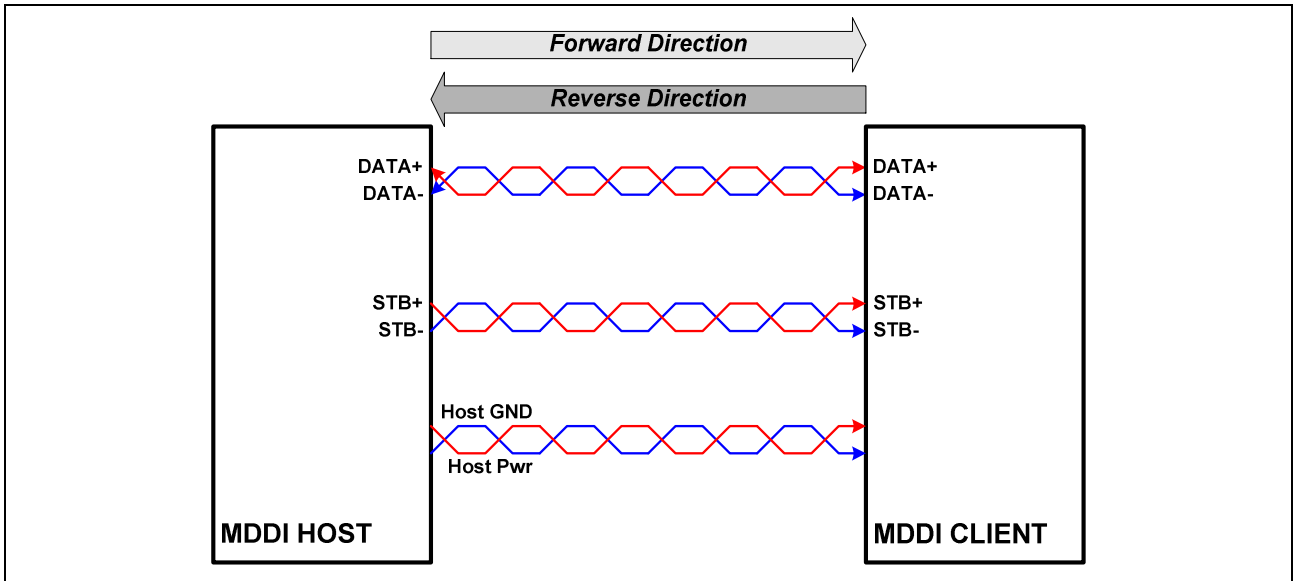

Figure 58. Physical Connection of MDDI Host and Client

10.3.2. DATA-STB Encoding

Data is encoded using a DATA-STB method. DATA is carried over a bi-directional differential cable, while STB is carried over a unidirectional differential cable driven only by the host. Figure below illustrates how the data sequence “1110001011” is transmitted using DATA-STB encoding.

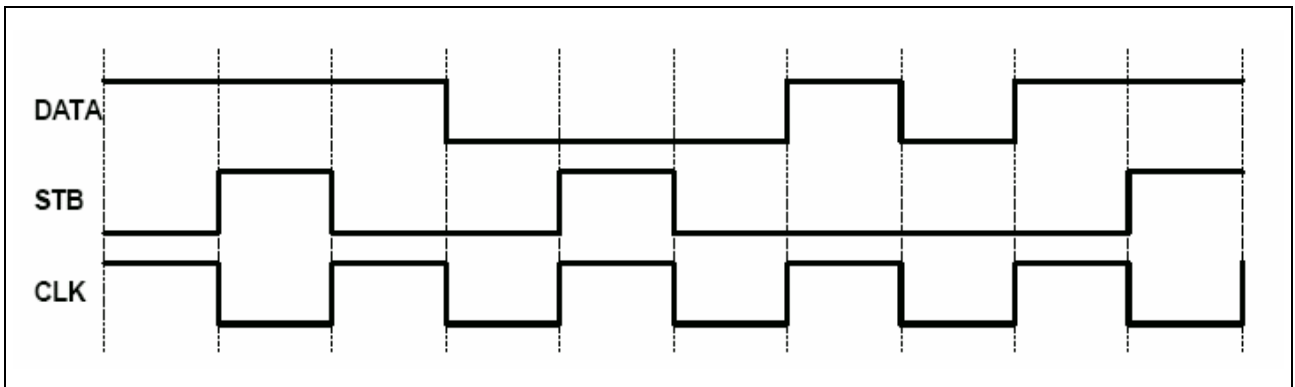

Figure 59. DATA-STB Encoding

The Following figure shows a sample circuit to generate DATA and STB from input data, and then recover the input data from DATA and STB.

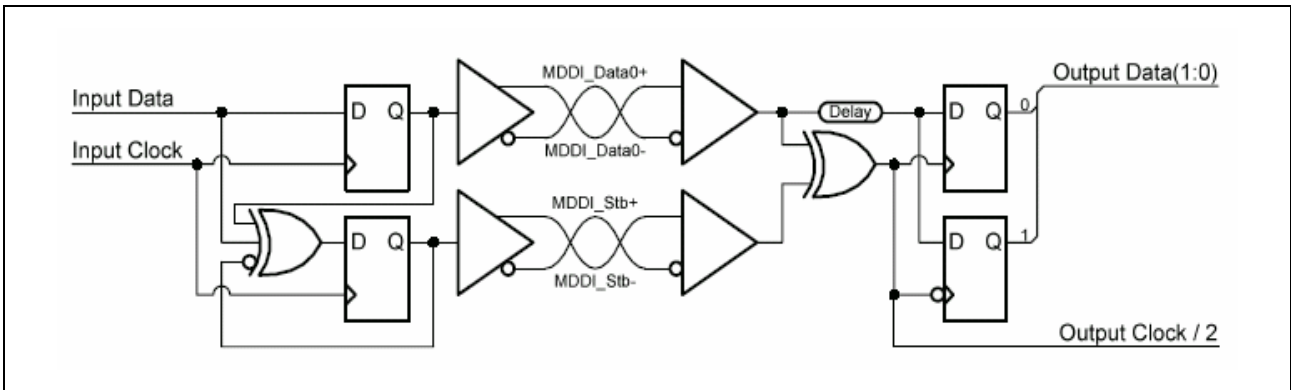

Figure 60. DATA / STB Generation & Recovery Circuit

10.3.3. MDDI DATA / STB

The Data (MDP/MDN) and STB(MSP/MSN) signals are always operated in a differential mode to maximize noise immunity. Each differential pair is parallel-terminated with the characteristic impedance of the cable. All parallel-terminations are in the client device. Figure below illustrates the configuration of the drivers, receivers, and terminations. The driver of each signal pair has a differential current output. While receiving MDDI packets the MDDI_DATA and MDDI_STB pairs use a conventional differential receiver with a differential voltage threshold of zero volts. In the hibernation state the driver outputs are disabled and the parallel termination resistors pull the differential voltage on each signal pair to zero volts. During hibernation a special receiver on the MDDI_DATA pairs has an offset input differential voltage threshold of positive 125 mV, which causes the hibernation line receiver to interpret the un-driven signal pair as logic-zero level.

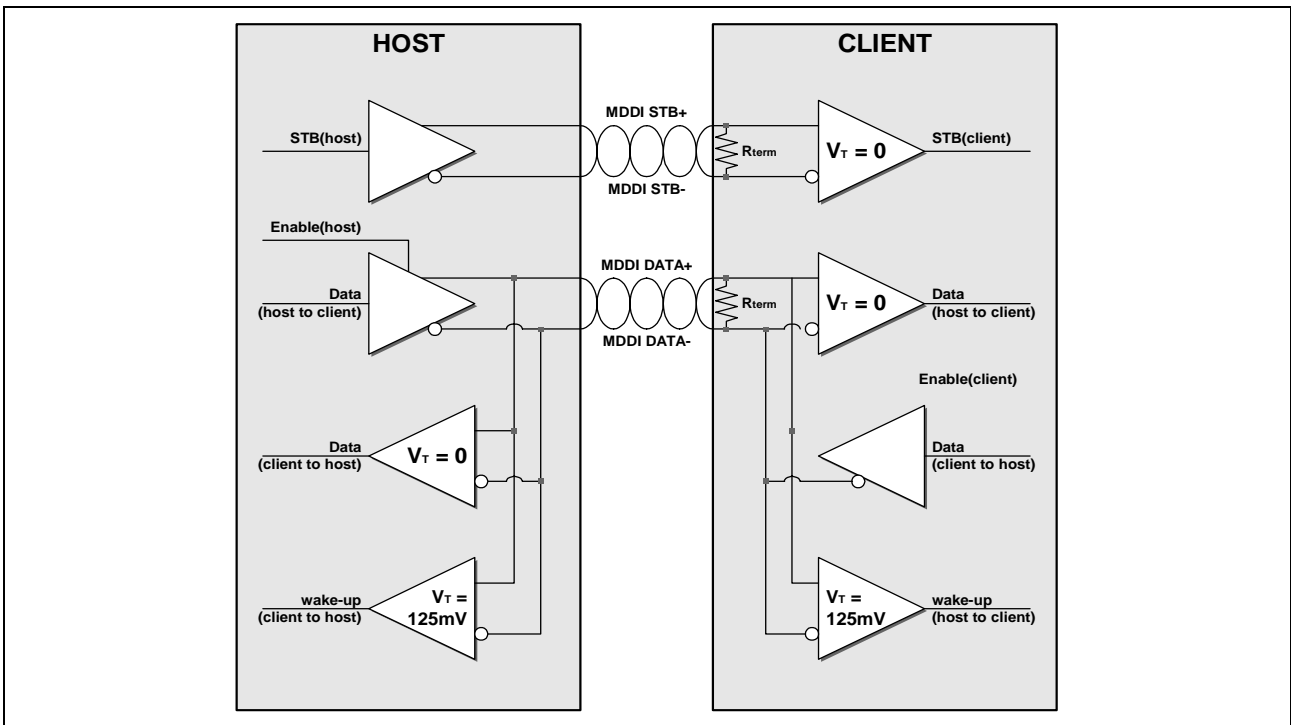

Figure 61. Differential Connection between Host and Client

10.3.4. Hibernation / Wake-up

S6E63D6 support hibernation mode for reducing interface power consumption.

The MDDI link can enter the hibernation state quickly and wake up from hibernation quickly. This allows the system to force the MDDI link into hibernation frequently to reduce power consumption.

In hibernation mode, hi-speed transceivers and receivers are disabled and low-speed & low-power receivers are enabled to detect wake-up sequence.

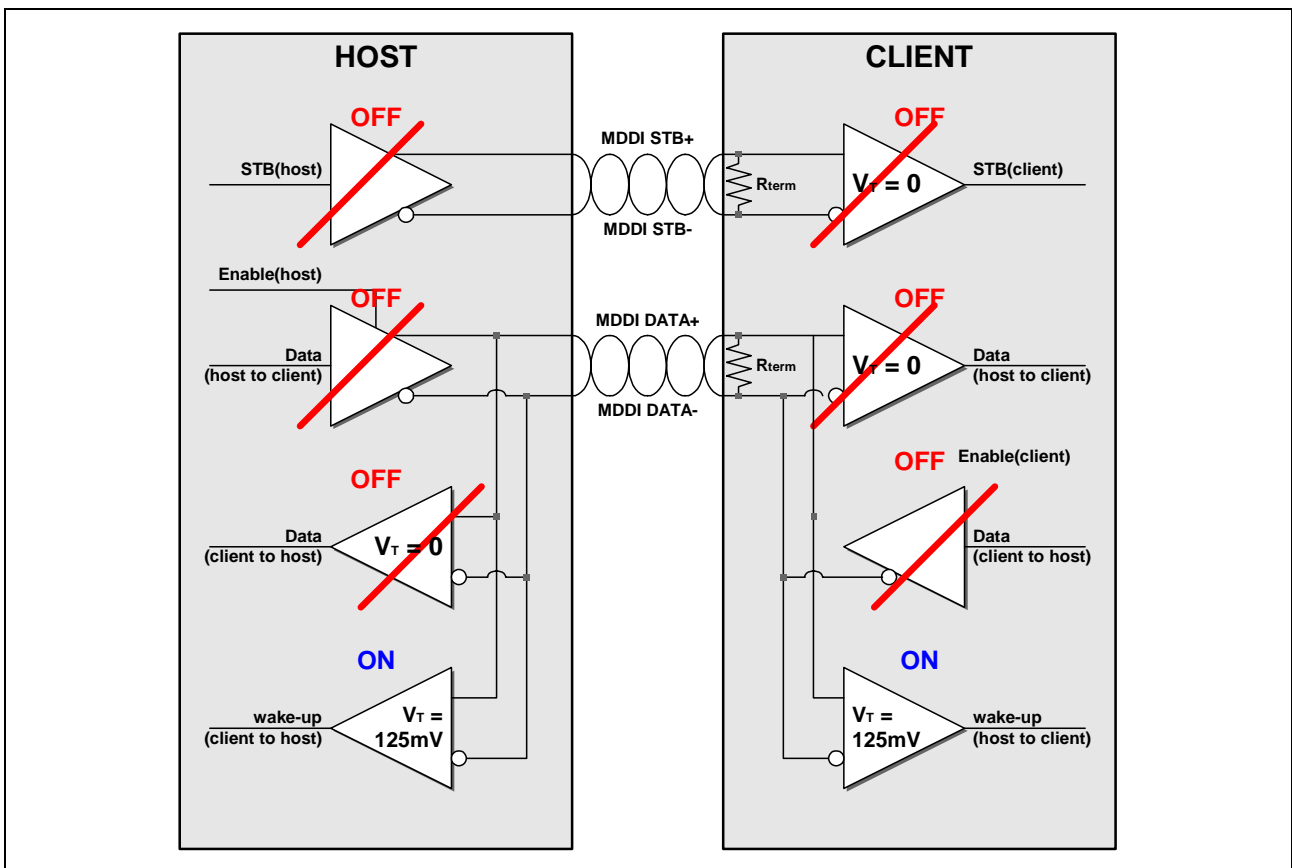

Figure 62. MDDI Transceiver / Receiver State in Hibernation

When the link wakes up from hibernation the host and client exchange a sequence of pulses. These pulses can be detect using low-speed, low-power receivers that consume only a fraction of the current of the differential receivers required to receive the signals at the maximum link operating speed.

Both the client and the host can wake up the link, so 2-types of wake-up are supported in S6E63D6: Host-initiated link wakeup and Client-initiated link wakeup.

10.3.5. MDDI Link Wake-up Procedure

10.3.5.1. Rules for Entering the Hibernation State

- The host sends 64 MDDI_Stb cycles after the CRC of the Link Shutdown Packet. Also after this CRC the host shall drive MDDI_Data0 to a logic-zero level and disable the MDDI_Data0 output of the host in the range of after the rising edge of the 16th to before the rising edge of the 48th MDDI_Stb cycles (including output disable propagation delays).
- The host shall finish sending the 64 MDDI_Stb cycles after the CRC of the Link Shutdown packet before it initiates the wake-up sequence.
- The client shall wait until after the rising edge of the 48th MDDI_Stb cycle after the CRC of the Link Shutdown Packet or later before it drives MDDI_Data0 to a logic-one level to attempt to wake-up the host.
- The client shall place its high-speed receivers for MDDI_Data0 and MDDI_Stb into hibernation any time after the rising edge of the 48th MDDI_Stb cycle after the CRC of the Link Shutdown Packet. It is recommended that the client place its high-speed MDDI_Data0 and MDDI_Stb receivers into hibernation before the rising edge of the 64th MDDI_Stb cycle after the CRC of the Link Shutdown Packet.

10.3.5.2. Rules for Wake-up from the Hibernation State

- When the client needs service from the host it generates a request pulse by driving MDDI_Data0 to a logic-one level for 70 to 1000 μ sec while MDDI_Stb is inactive and keeps MDDI_Data0 driven to a logic-one level for 70 MDDI_Stb cycles (range of 60 to 80) after MDDI_Stb becomes active. Then the client disables the MDDI_Data0 driver by placing it into a high-impedance state.
- If MDDI_Stb is active during hibernation (which is unlikely, but allowed per the spec) then the client may only drive MDDI_Data0 to a logic one level for 70 MDDI_Stb cycles (range of 60 to 80). This action causes the host to restart data traffic on the forward link and to poll the client for its status.
- The host shall detect the presence of the request pulse from the client (using the low-power differential receiver with a +125mV offset) and begin the startup sequence by first driving MDDI_Stb to a logic-zero level and MDDI_Data0 to a logic-high level for at least 200nsec, and then while toggling MDDI_Stb it shall continue to drive MDDI_Data0 to a logic-one level for 150 MDDI_Stb cycles (range of 140 to 160) and to logic-zero for 50 MDDI_Stb cycles. The client shall not send a service request pulse if it detects MDDI_Data0 at a logic-one level for more than 80 MDDI_Stb

cycles. After the client has detected MDDI_Data0 at a logic-one level for 60 to 80 MDDI_Stb cycles it shall begin to search for the interval where drives MDDI_Data0 to a logic-zero level for 50 MDDI_Stb cycles then the host starts sending packets on the link. The first packet sent shall be a Sub-frame Header Packet. The client begins to look for the Sub-frame header Packet after MDDI_Data0 is at a logic-zero level for 40 MDDI_Stb cycles of the 50 cycle interval.

- The host may initiate the wake-up by first enabling MDDI_Stb and simultaneously drive it to a logic-zero level. MDDI_Stb shall not be driven to a logic-one level until pulses are output as described below. After MDDI_Stb reaches a valid logic-zero level the host shall enable MDDI_Data0 and simultaneously drive it to a logic-one level. MDDI_Data0 shall not be driven to a logic-zero level during the wake-up process until the interval where it is driven to a logic-zero level for an interval of 50 MDDI_Stb pulses as described below. The host shall wait at least 200 nsec after MDDI_Data0 reaches a valid logic-one level before driving pulses on MDDI_Stb. This timing relationship shall always occur while considering the worst-case output enable delays. This guarantees that the client has sufficient time to fully enable its MDDI_Stb receiver after being woken up by a logic-one level on MDDI_Data0 that was driven by the host.

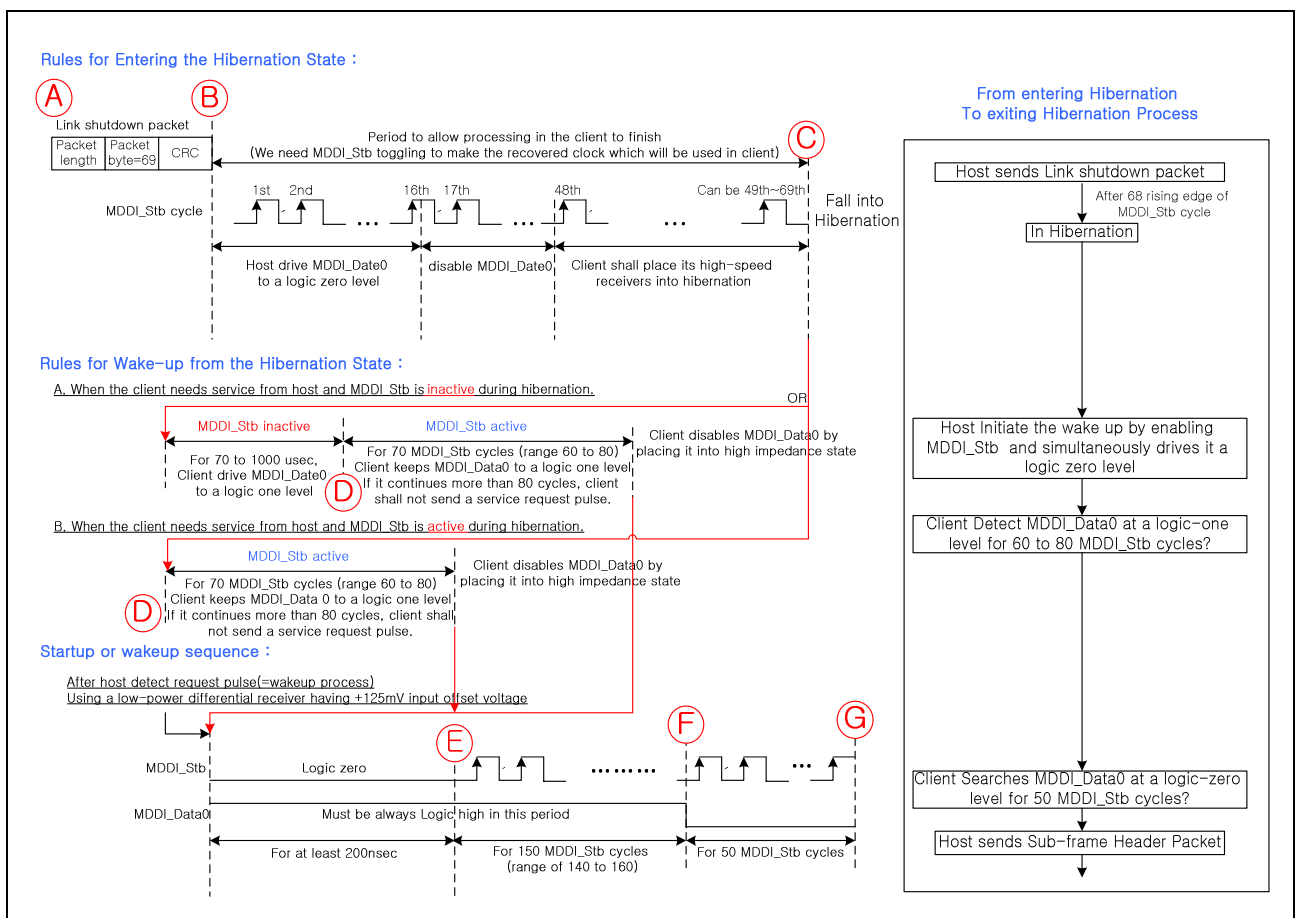

Figure 63. Process from Entering Hibernation to Exiting Hibernation

10.3.5.3. Host-initiated Link Wake-up Procedure

The simple case of a host-initiated wake-up is described below without contention from the client trying to wake up at the same time. The following sequence of events is illustrated in the following figure.

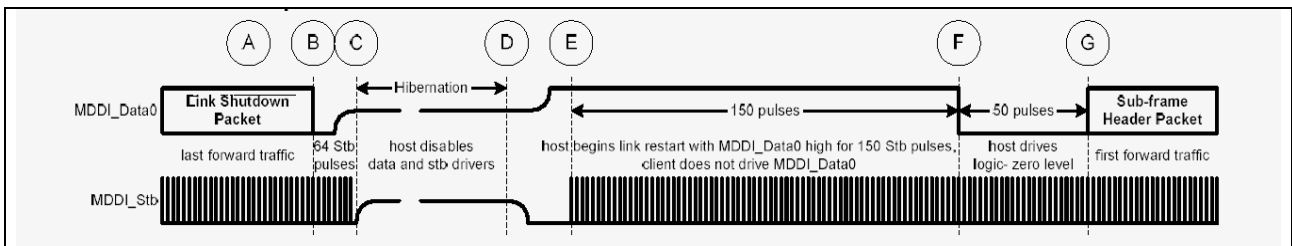

Figure 64. Host-initiated Link Wake-up Procedure

The Detailed descriptions for labeled events are as follows:

A. The host sends a Link Shutdown Packet to inform the client that the link will transition to the low-power hibernation state.

B. Following the CRC of the Link Shutdown Packet the host toggles MDDI_Stb for 64 cycles to allow processing in the client to finish before it stops MDDI_Stb from toggling which stops the recovered clock in the client device.

Also during this interval the host initially sets MDDI_Data0 to a logic-zero level, and then disables the MDDI_Data0 output in the range of 16 to 48 MDDI_Stb cycles (including output disable propagation delays) after the CRC.

It may be desirable for the client to place its high-speed receivers for MDDI_Data0 and MDDI_Stb into a low power state any time after 48 MDDI_Stb cycles after the CRC and before point C.

C. The host enters the low-power hibernation state by disabling the MDDI_Data0 and MDDI_Stb drivers and by placing the host controller into a low-power hibernation state.

It is also allowable for MDDI_Stb to be driven to logic-zero level or to continue toggling during hibernation. The client is also in the low-power hibernation state.

D. After a while, the host begins the link restart sequence by enabling the MDDI_Data0 and MDDI_Stb driver outputs. The host drives MDDI_Data0 to a logic-one level and MDDI_Stb to logic-zero level for at least the time it takes for the drivers to fully enable their outputs.

The host shall wait at least 200 nsec after MDDI_Data0 reaches a valid logic-one level and MDDI_Stb reaches a valid logic-zero level before driving pulses on MDDI_Stb. This gives the client sufficient time to prepare to receive high-speed pulses on MDDI_Stb. The client first detects the wake-up pulse using a low-power differential receiver having a +125mV input offset voltage.

E. The host drivers are fully enabled and MDDI_Data0 is being driven to a logic-one level.

The host begins to toggle MDDI_Stb in a manner consistent with having a logic-zero level on MDDI_Data0 for a duration of 150 MDDI_Stb cycles.

F. The host drives MDDI_Data0 to logic-zero level for 50 MDDI_Stb cycles. The client begins to look for the Sub-frame Header Packet after MDDI_Data0 is at logic-zero level for 40 MDDI_Stb cycles.

G. The host begins to transmit data on the forward link by sending a Sub-frame Header Packet. Beginning at point G the MDDI host generates MDDI_Stb based on the logic level on MDDI_Data0 so that proper data-strobe encoding commences from point G.

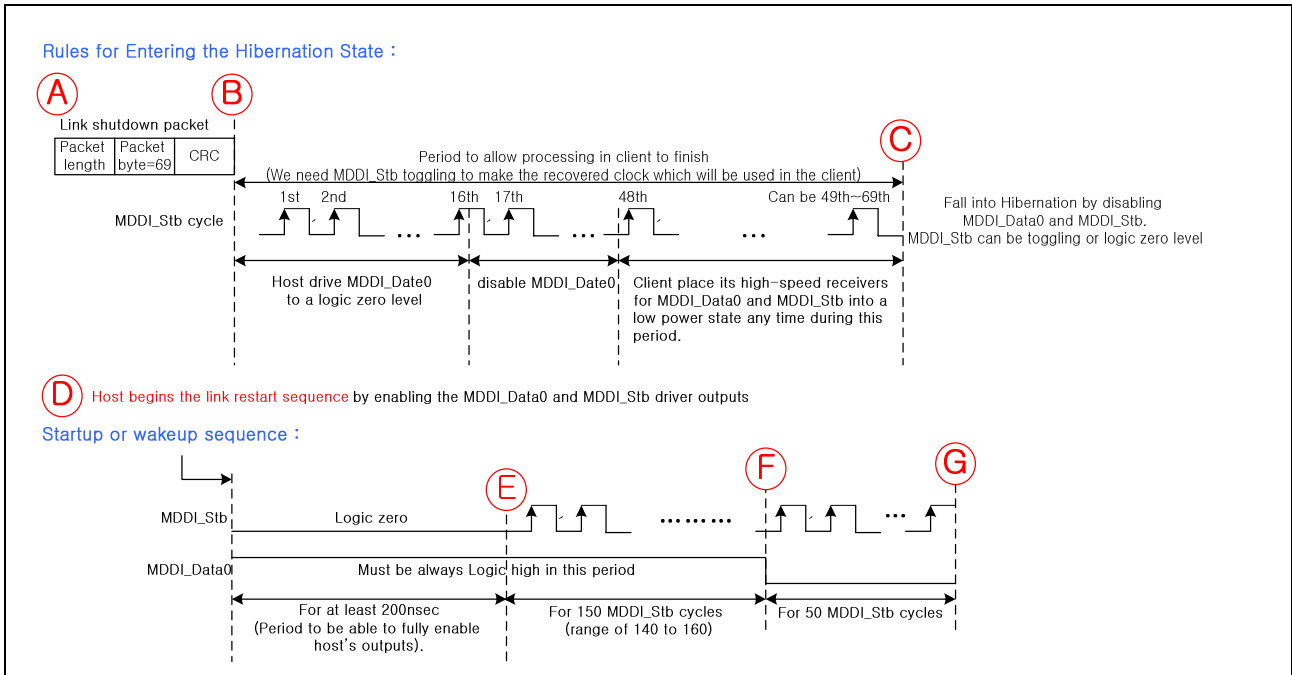

Figure 65. Host-initiated Link Wake-up Sequence

Host-initiated Wake-up from Hibernation with Connection from client

This is actually a host-initiated wake-up, but we have included the case where the client also wants to wake up the link with the latest possible request. The labeled events are :

- A. The host sends a Link Shutdown Packet to inform the client that the link will transition to the low-power hibernation state.
- B. Following the CRC of the Link Shutdown Packet the host toggles MDDI_Stb for 64 cycles to allow processing in the client to finish before it stops MDDI_Stb from toggling which stops the recovered clock in the client device. Also during this interval the host disables the MDDI_Data0 output in the range of 16 to 48 MDDI_Stb cycles(including output disable propagation delays) after the CRC. It may be desirable for the client to place its high-speed receivers for MDDI_Data0 and MDDI_Stb into a low power state any time after 48 MDDI_Stb cycles after the CRC and before point C.
- C. The host enters the low-power hibernation state by disabling its MDDI_Data0 and MDDI_Stb driver outputs. It is also allowable for MDDI_Stb to be driven to a logic-zero level or to continue toggling during hibernation. The client is also in the low-power hibernation state.
- D. After a while, the host begins the link restart sequence by enabling the MDDI_Data0 and MDDI_Stb driver outputs. The host drives MDDI_Data0 to a logic-one level and MDDI_Stb to a logic-zero level for at least the time it takes for the drivers to fully enable their outputs. The host shall wait at least 200 nsec after MDDI_Data0 reaches a valid logic-one level and MDDI_Stb reaches a valid logic-zero level before driving pulses on MDDI_Stb. This gives the client sufficient time to prepare to receive high-speed pulses on MDDI_Stb.

E. The host drivers are fully enabled and MDDI_Data0 is being driven to a logic-one level. The host begins to toggle MDDI_Stb in a manner consistent with having a logic-zero level on MDDI_Data0 for a duration of 150 MDDI_Stb cycles.

F. At up to 70 MDDI_Stb cycles after point E the client has not yet recognized that the host is driving MDDI_Data0 to a logic-one level so the client also drives MDDI_Data0 to a logic-one level. This occurs because the client has a need to request service from the host and does not recognize that the host has already begun the link restart sequence.

G. The client ceases to drive MDDI_Data0, and places its driver into a high-impedance state by disabling its output. The host continues to drive MDDI_Data0 to a logic-one level for 80 additional MDDI_Stb cycles.

H. The host drives MDDI_Data0 to a logic-zero level for 50 MDDI_Stb cycles. The client begins to look for the Sub-frame Header Packet after MDDI_Data0 is at a logic-zero level for 40 MDDI_Stb cycles.

I. The host begins to transmit data on the forward link by sending a Sub-frame Header Packet. Beginning at point I the MDDI host generates MDDI_Stb based on the logic level on MDDI_Data0 so that proper data-strobe encoding commences from point I.

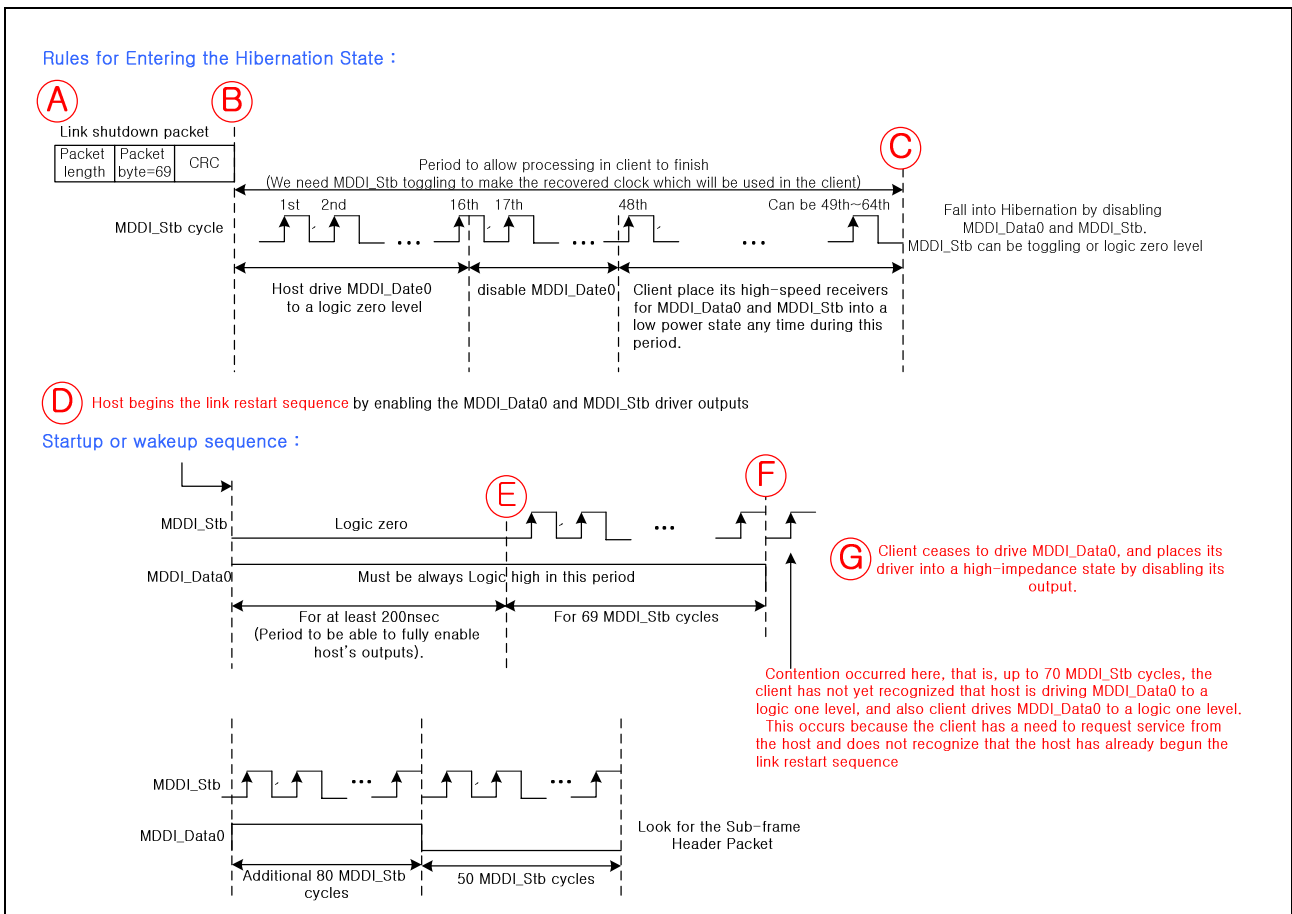

Figure 66. Host-initiated Wake-up Process from Hibernation with Connection from Client

10.3.5.4. Client-initiated Link Wake-up Procedure

An example of a typical client-initiated service request event with no contention is illustrated in the following figure.

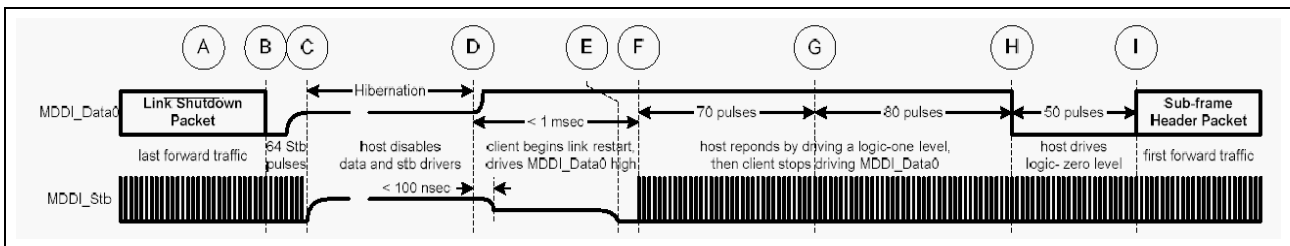

Figure 67. Client-initiated Link Wake-up Procedure

The Detailed descriptions for labeled events are as follows:

A. The host sends a Link Shutdown Packet to inform the client that the link will transition to the low-power hibernation state.

B. Following the CRC of the Link Shutdown Packet the host toggles MDDI_Stb for 64 cycles to allow processing in the client to finish before it stops MDDI_Stb from toggling which stops the recovered clock in the client device.

Also during this interval the host initially sets MDDI_Data0 to a logic-zero level, and then disables the MDDI_Data0 output in the range of 16 to 48 MDDI_Stb cycles (including output disable propagation delays) after the CRC.

It may be desirable for the client to place its high-speed receivers for MDDI_Data0 and MDDI_Stb into a low power state any time after 48 MDDI_Stb cycles after the CRC and before point C.

C. The host enters the low-power hibernation state by disabling its MDDI_Data0 and MDDI_Stb driver outputs.

It is also allowable for MDDI_Stb to be driven to logic-zero level or to continue toggling during hibernation. The client is also in the low-power hibernation state.

D. After a while, the client begins the link restart sequence by enabling the MDDI_Stb receiver and also enabling an offset in its MDDI_Stb receiver to guarantee the state of the received version of MDDI_Stb is a logic-zero level in the client before the host enables its MDDI_Stb driver.

The client will need to enable the offset in MDDI_Stb immediately before enabling its MDDI_Stb receiver to ensure that the MDDI_Stb receiver in the client is always receiving a valid differential signal and to prevent erroneous received signals from propagating into the client.

After that, the client enables its MDDI_Data0 driver while driving MDDI_Data0 to a logic-one level. It is allowed for MDDI_Data0 and MDDI_Stb to be enabled simultaneously if the time to enable the offset and enable the standard MDDI_Stb differential receiver is less than 200 nsec.

E. Within 1 msec the host recognizes the service request pulse, and the host begins the link restart sequence by enabling the MDDI_Data0 and MDDI_Stb driver outputs.

The host drives MDDI_Data0 to a logic-one level and MDDI_Stb to a logic-zero level for at least the time it takes for the drivers to fully enable their outputs. The host shall wait at least 200 nsec after MDDI_Data0 reaches a valid logic-one level and MDDI_Stb reaches a valid fully-driven logic-zero level before driving pulses on MDDI_Stb.

This gives the client sufficient time to prepare to receive high-speed pulses on MDDI_Stb.

F. The host begins outputting pulses on MDDI_Stb and shall keep MDDI_Data0 at a logic-one level for a total duration of 150 MDDI_Stb pulses through point H. The host generates MDDI_Stb in a manner consistent with sending a logic-zero level on MDDI_Data0. When the client recognizes the first pulse on MDDI_Stb it shall disable the offset in its MDDI_Stb receiver.

G. The client continues to drive MDDI_Data0 to a logic-one level for 70 MDDI_Stb pulses, and the client disables its MDDI_Data0 driver at point G. The host continues to drive MDDI_Data0 to a logic-one level for duration of 80 additional MDDI_Stb pulses, and at point H drives MDDI_Data0 to logic-zero level.

H. The host drives MDDI_Data0 to logic-zero level for 50 MDDI_Stb cycles. The client begins to look for the Sub-frame Header Packet after MDDI_Data0 is at logic-zero level for 40 MDDI_Stb cycles.

I. After asserting MDDI_Data0 to logic-zero level and driving MDDI_Stb for duration of 50 MDDI_Stb pulses the host begins to transmit data on the forward link at point I by sending a Sub-frame Header Packet. The client begins to look for the Sub-frame Header Packet after MDDI_Data0 is at logic-zero level for 40 MDDI_Stb cycles.

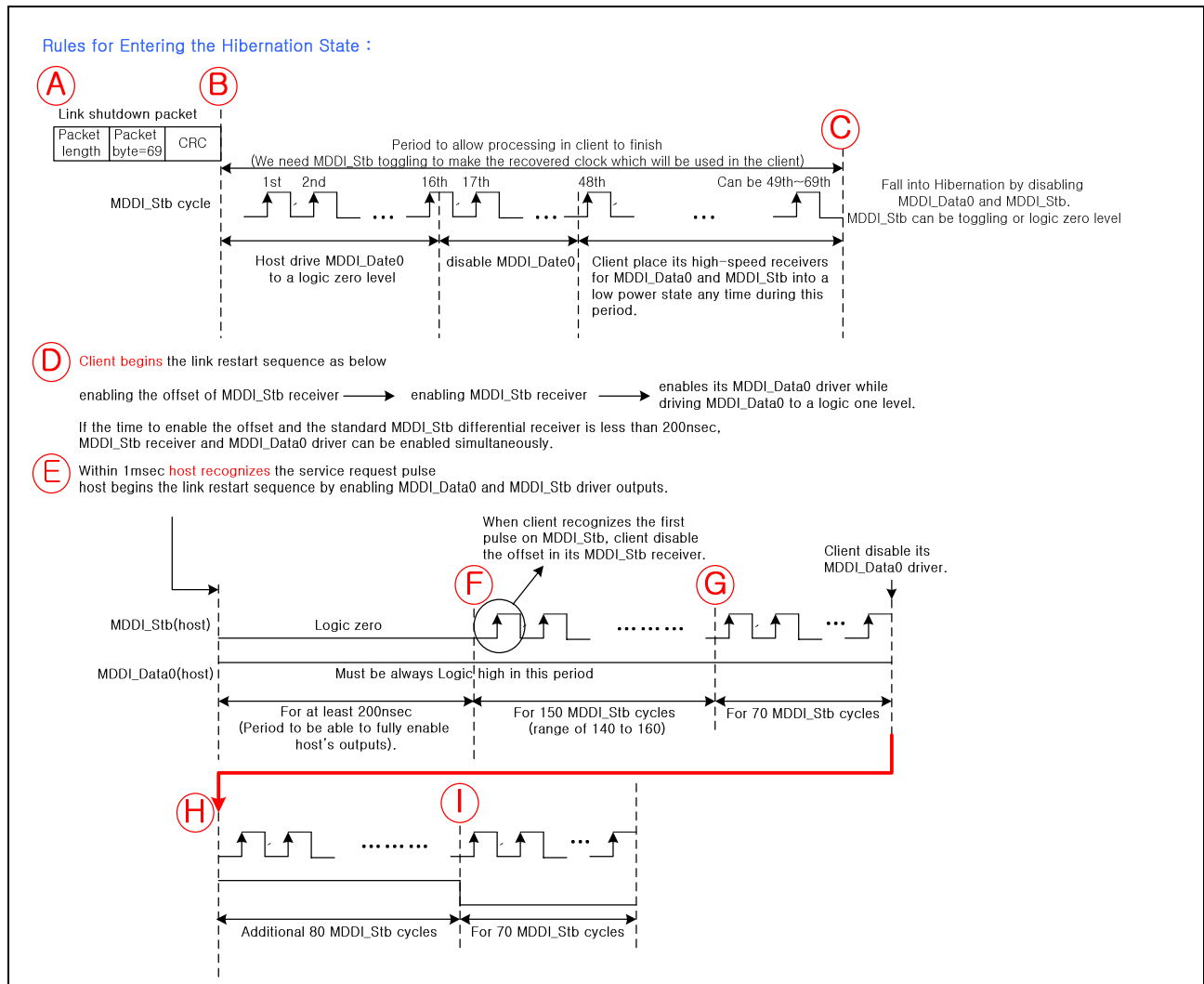

Figure 68. Client-initiated Link Wake-up Sequence

S6E63D6 supports 2-types of client-initiated link wake-up: VSYNC based Link Wake-up & GPIO based Link Wake-up. As client-initiated wake-up action is executed in hibernation state only, register setting for each wake-up have to be set before link shut-down.

VSYNC Based Link Wake-up

In display-ON state, when the IC finishes displaying all internal GRAM data, data request must be transferred to MDDI host for new video data. As MDDI link is usually in hibernation for reducing interface power consumption, MDDI link wake-up must be done before internal GRAM update. In that case, client initiated link wake-up can be used as data request.

When VSYNC based link wake-up register (50h: VWAKE_EN) is set, client initiated wake-up is executed in synchronization with the vertical-sync signal which generated in S6E63D6. Using VSYNC based link wake-up, tearing-less display can be accomplished if interface speed and wake-up time is well known.

The following figure shows detailed timing for VSYNC based link wake-up.

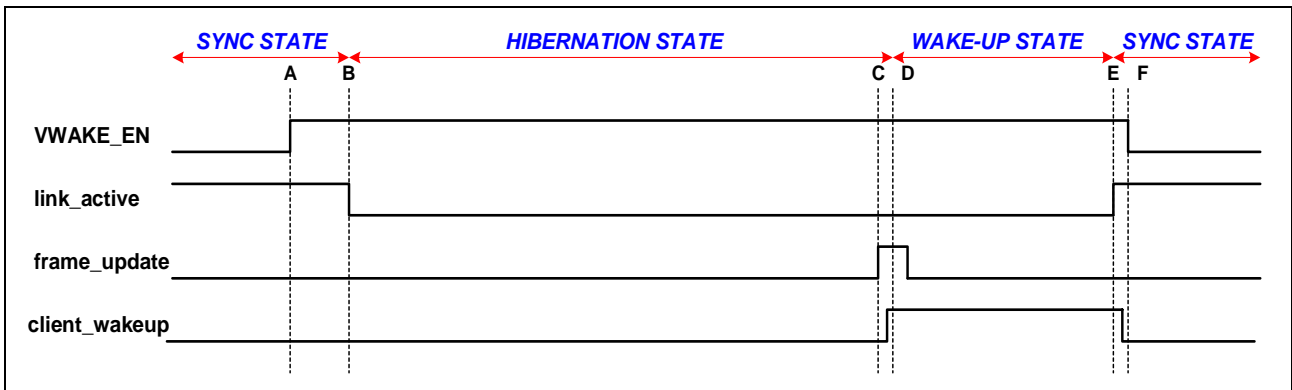

Figure 69. VSYNC Based Link Wake-up Procedure

The Detailed descriptions for labeled events are as follows:

A. MDDI host writes to the VSYNC based link wakeup register to enable a wake-up based on internal vertical-sync signal.

B. link_active goes low when the host puts in the link into hibernation after no more data needs to be sent to the S6E63D6.

C. frame_update, the internal vertical-sync signal goes high indicating that update pointer has wrapped around and is now reading from the beginning of the frame buffer. Link wake-up point can be set using WKF and WKL (51h) registers. WKF specifies the number of frame before wake-up; WKL specifies the number of lines before wake-up.

D. client_wakeup input to the MDDI client goes high to start the client initiated link wake-up.

E. link_active goes high after the host brings the link out of hibernation.

F. After link wake-up, client_wakeup signal and the VWAKE_EN register are cleared automatically.

GPIO Based Link Wake-up

In VSYNC-based link wake-up, wake-up enable register setting prior to link shut-down. GPIO based Link wake-up is enabled by interrupt from outside of the IC. For GPIO based link wake-up, GPIO interrupt enable and GPIO PAD mode (to input mode) setting must be set. Once S6E63D6 receive interrupt, internal GPIO base link wake-up flag set to high, and the following procedure is similar to that of VSYNC based link wake-up.

The following figure shows detailed timing for GPIO based link wake-up.

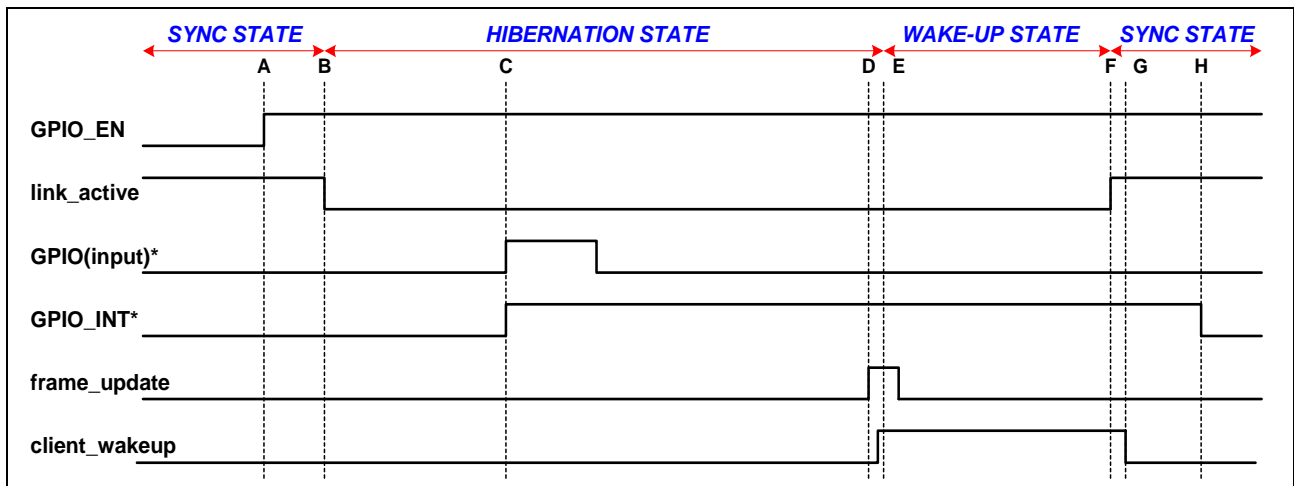

Figure 70. GPIO Based Link Wake-up Procedure

The Detailed descriptions for labeled events are as follows:

A. Host sets the GPIO interrupt enable register (69h: GPIO_EN) for a particular GPIO through register access packet.

B. Link goes into hibernation (and link_active) goes low) when the host has no more data to send to the IC.

C. GPIO input goes high, and the GPIO interrupt (GPIO_INT) is latched.

D. Frame_update signal goes high indicating that the display has wrapped around. Link wake-up point can be set using WKF and WKL (51h) registers.

E. Client_wakeup input to the MDDI client goes high to start the client initiated link wake-up.

F. Link_active goes high after the host brings the link out of hibernation.

G. After link wake-up, client_wakeup signal is reset to low.

H. MDDI host clears the interrupt by writing to the interrupt clear register with the bit set for that particular interrupt (GPCLR: 68h). Between point G and H the host will have read the GPIO_INT values to see what interrupts are active.

10.3.6. GPIO Control

S6E63D6 offers 10(maximum) GPIO that can be used as input or output independently.

Some application or device on the upper clamshell needs several control signals which are supplied by base band modem or application processor directly. If number of application on the upper clamshell increases, also control signals increase, causing the interface more costly.

In S6E63D6, GPIO can be the solution for that problem. User may control the 10 GPIOs as input or output by use of simple register setting. So additional connection between base band modem / AP (application processor) and components on upper clamshell are not needed.

The following table shows several set of register for GPIO.

Table 66. The Description of register for GPIO

Register	Width	Description		Reset Value
GPIO (66h)	[9:0]	Write	For GPIO output mode: output GPIO register(66h) value to GPIO PAD	10'h000
		Read	GPIO PAD status	
GPIO_CON (67h)	[9:0]	Write	GPIO PAD input/output mode control : (0 : input / 1 : output)	10'h000
		Read	GPIO_CON (67h) register value	
GPCLR (68h)	[9:0]	Write	For GPIO input mode: clear specified GPIO interrupt (set by GPIO PAD input).	10'h000
		Read	GPIO interrupt state (set by GPIO PAD input).	
GPIO_EN (69h)	[9:0]	Write	For GPIO input mode: enable specified GPIO interrupt	10'h000
		Read	GPIO_EN (69h) register value.	
GPPOL (6Ah)	[9:0]	Write	For GPIO input mode: GPIO interrupt polarity setting	10'h3FF
		Read	GPPOL (6Ah) register value.	

In GPIO output mode, the IC output GPIO (66h) register value to the defined PAD.

Set GPIO_CON register as output mode before use GPIO output.

10 different GPIO output can be controlled simultaneously using 1-register access packet (66h register access) so that minimum access time for each GPIO output will be 1-register access time.

GPIO input mode can only be used as client-initiated link wake-up.

For more information, refer to GPIO based link wake-up section.

10.3.7. MDDI Packet

MDDI transfer data by packet format. MDDI host can make many packets and transfer them. In S6E63D6, several packets format is supported. Most packets are transferred from MDDI host to client (forward direction); but reverse encapsulation packet is transferred from MDDI client to host (reverse direction).

A number of packets, started by sub-frame header packet, construct 1 sub frame.

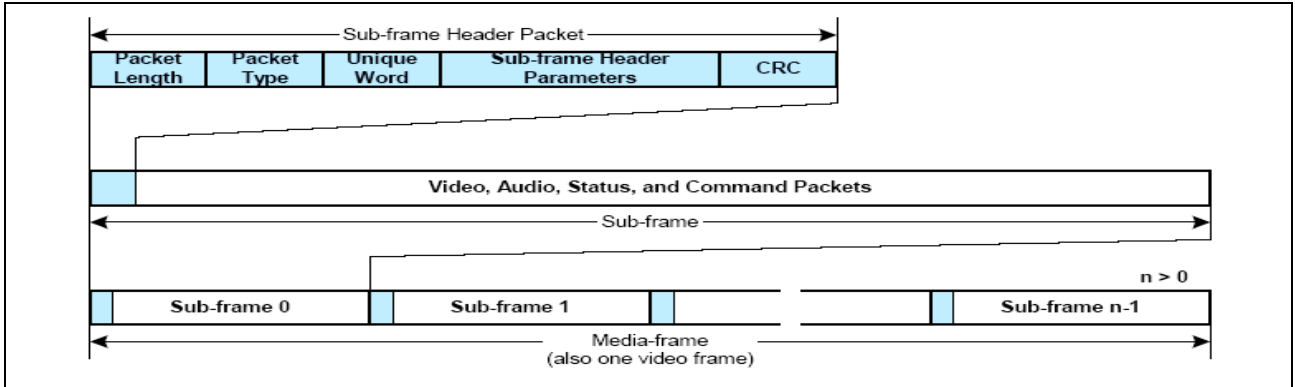

Figure 71. MDDI Packet Structure

Refer to MDDI packet structure, sub-frame header packet is placed in front of a sub-frame, and some sub-frame construct media-frame together.

The following table describes 9 types of packet which is supported in S6E63D6.

Table 67. MDDI Packet and Function

Packet	Function	Direction
Sub-frame header packet	Header of each sub frame	Forward
Register access packet	Register setting	Forward
Video stream packet	Video data transfer	Forward
Filler packet	Fill empty packet space	Forward
Reverse link encapsulation packet	Reverse data packet	Forward
Round-trip delay measurement packet	Host->client->host delay check	Forward/Reverse
Client capability packet	Capability of client check	Forward
Client request and status packet	Information about client status	Forward
Link shutdown packet	End of frame	Forward

10.3.7.3. Video Stream Packet

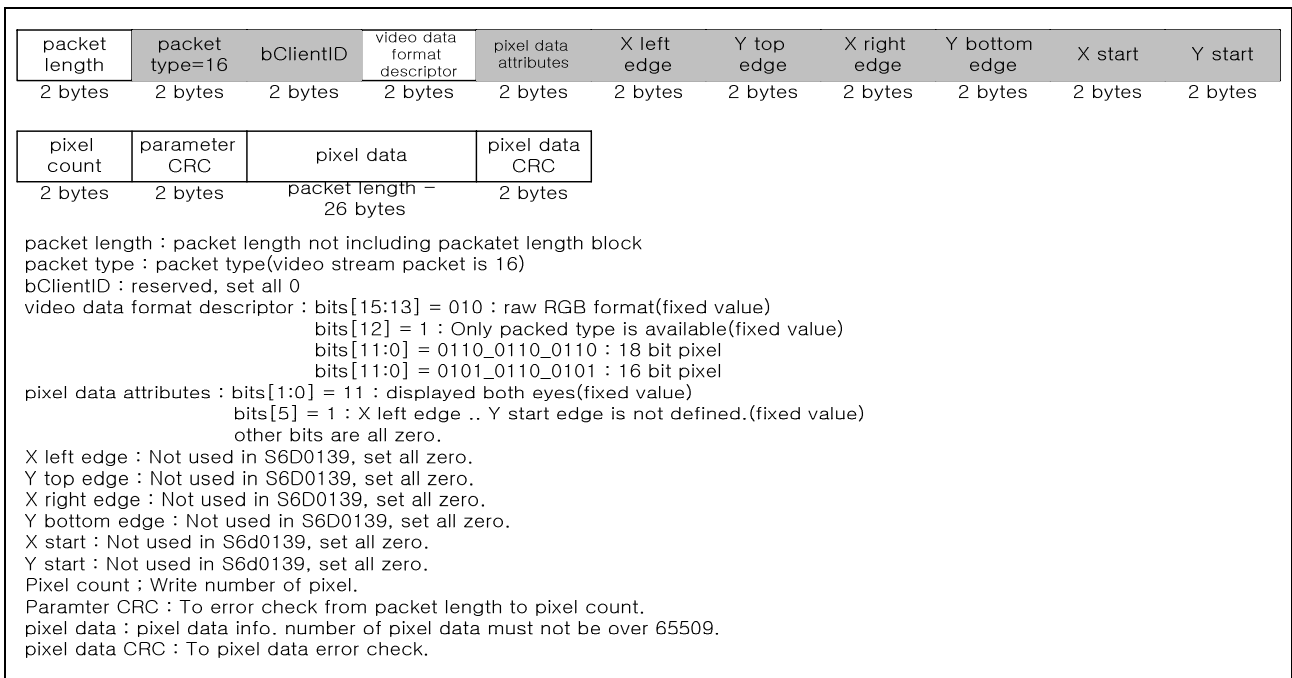

Figure 74. Video Stream Packet Structure

10.3.7.4. Filler Packet

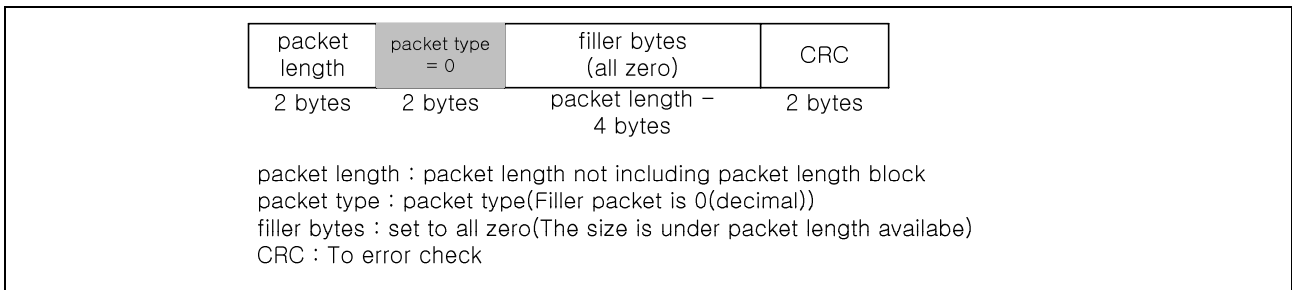
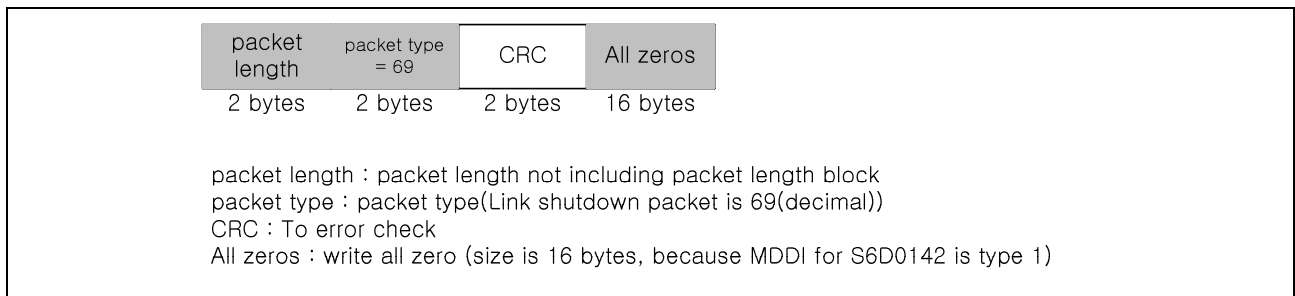



Figure 75. Filler Packet Structure

10.3.7.5. Link Shutdown Packet

**Figure 76. Link Shutdown Packet Structure**

 : fixed value

For More information about MDDI packet, please refer to VESA MDDI spec.

10.3.8. MDDI Operating State

In MDDI, six operation modes are available. The following table describes six modes.

Table 68. MDDI Operating State

STATE	OSC	Booster Circuit	Internal Logic status	MDDI I/O	Wake-up by
SLEEP	OFF	Disabled	Display OFF MDDI Link hibernation	Hibernation driver ON	Host – Initiated
WAIT	ON	Disabled	Display OFF MDDI Link in SYNC	standard driver ON	-
NORMAL	ON	Enabled	Display ON MDDI Link in SYNC	standard driver ON	-
NAP	ON	Disabled	Display OFF MDDI Link in SYNC	standard driver ON	-
IDLE	ON	Enabled	Display ON MDDI Link hibernation	Hibernation driver ON	Host – Initiated Client –Initiated (Vsync, GPIO)
STOP	OFF	Disabled	Display OFF MDDI Link OFF	Driver All OFF	RESET

SLEEP: Initial status when external power is connected to the IC.

In this state, internal oscillator is not operating, and MDDI link is in hibernation state.

As no command or signal is applied to the IC except RESET input, internal logic or booster circuit is OFF.

WAIT: After the wake-up sequence, the IC is in WAIT state. MDDI link is in SYNC, and internal logic or booster is still OFF because no other register access or video stream packet is transferred to the IC.

NORMAL: MDDI link, booster circuit, and internal logic circuit is ON. Register access or Video data transfer is available in NORMAL state.

IDLE: When no more video data update is needed, MDDI link is in hibernation so that interface power can be reduced. Internal booster circuit & logic circuits are still operating. MDDI link wakeup will be accomplished when vsync wakeup register is set before hibernation or GPIO interrupt is set.

NAP: This state is set by register access. Booster Circuit and Internal logic is OFF, but MDDI link is ON. MDDI link have to be in SYNC because the IC must receive commands for power save or normal operation

STOP: STOP state is set by register access (R10h). In this state, MDDI link, internal oscillator, booster, and logic circuit are all OFF. To release STOP state, input reset signal. After reset, status is SLEEP state.

The following figure shows the operating state in MDDI mode.

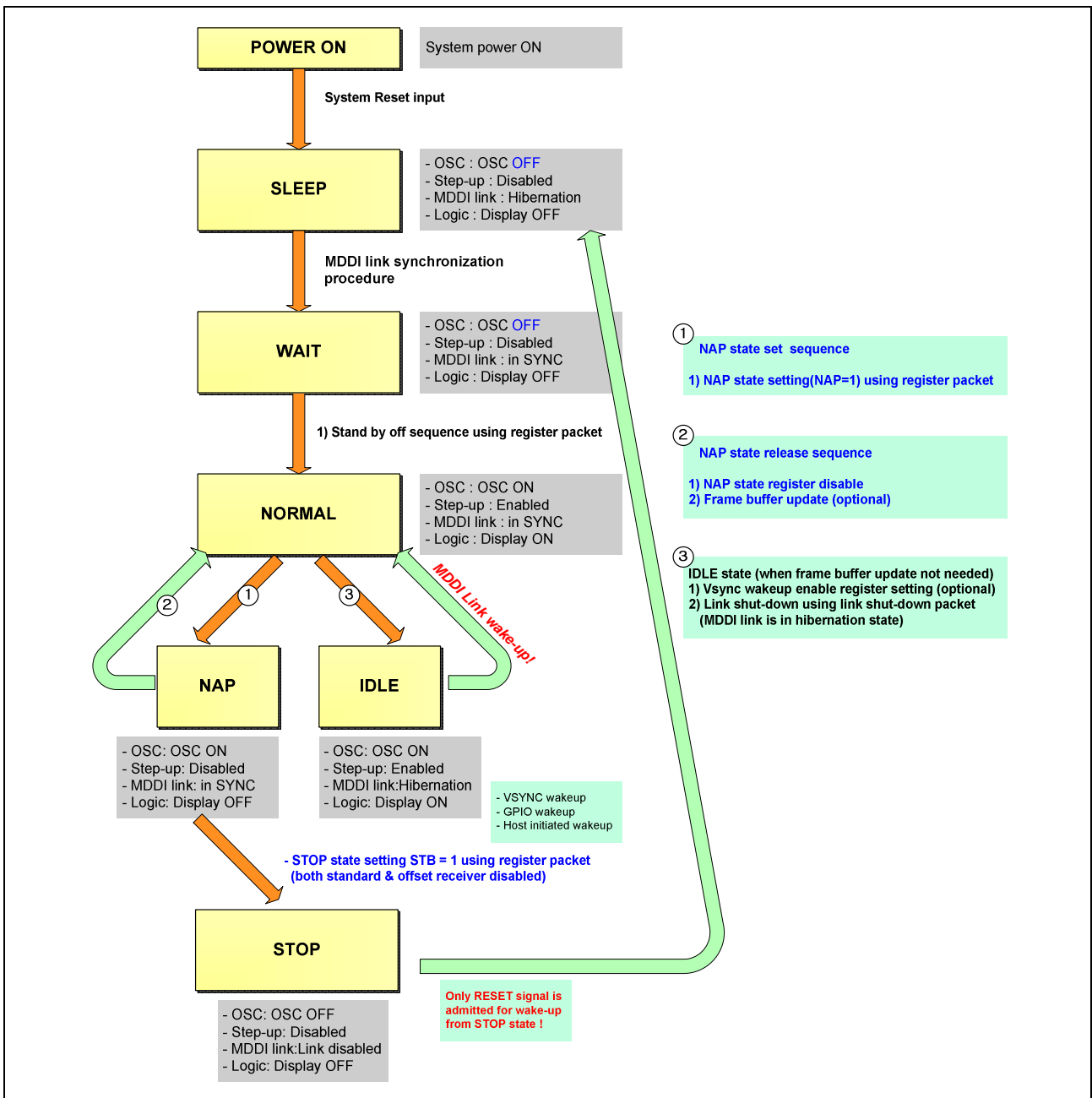

Figure 77. Operating State in MDDI mode

10.3.9. Tearing-less Display

In S6E63D6, the matching between data write timing and written data display timing is important. If timing is mismatched, tearing effect can occur.

To avoid display tearing effect, two possible ways are suggested.

First case is that data write is slower than speed of displaying written data. In this case, data write speed is not critical, but current consumption in interface will be increased because data transfer time is long.

Other case is that data write is faster than speed of displaying written data. In this case, data update speed is very high so that transfer time is short. So current consumption in interface can be minimized, but it requires fast data transfer. The most important thing is to avoid data scan conflicts with data update.

The following figures describe some examples to avoid display tearing phenomenon.

10.3.9.1. Display speed is faster than data write.

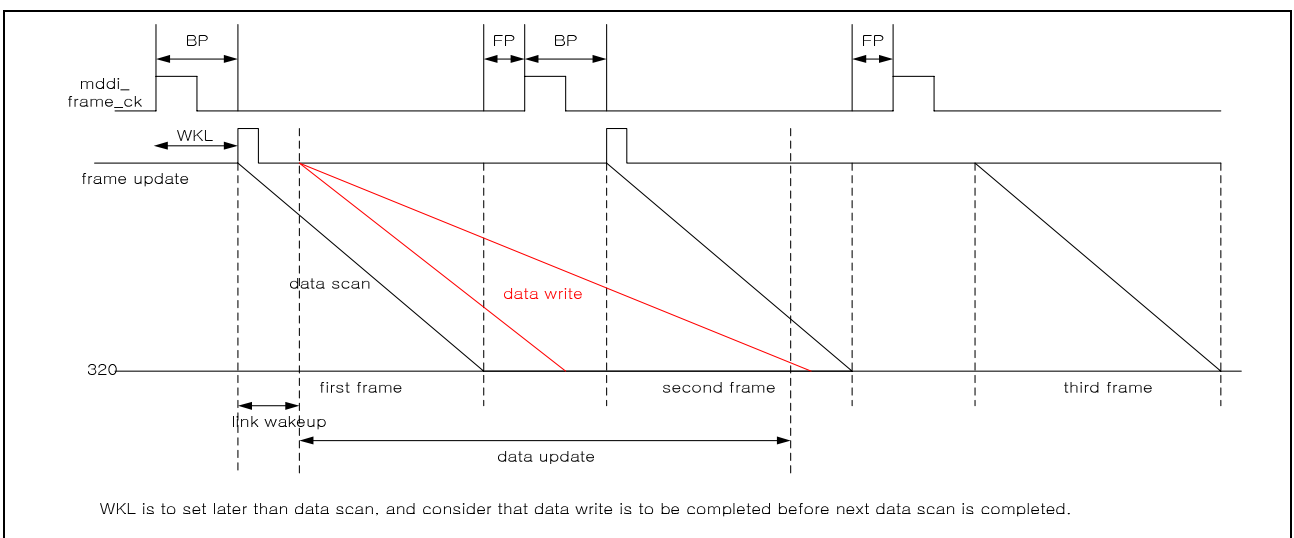

Figure 78. Tearing-less Display: Display speed is faster than data write.

10.3.9.2. Display speed is slower than data write.

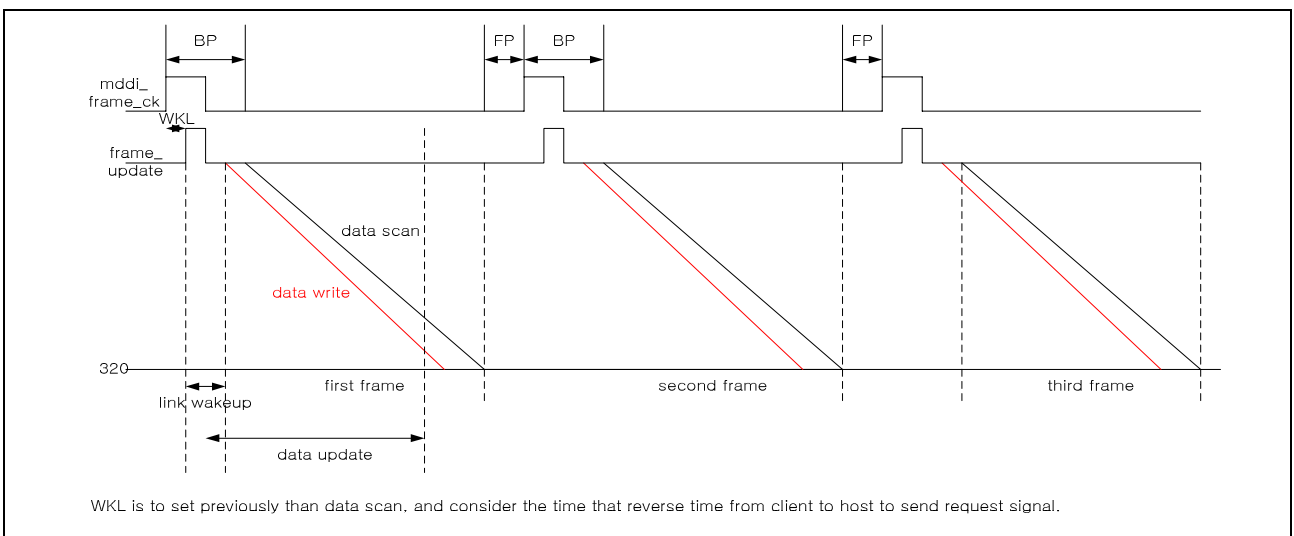

Figure 79. Tearing-less Display: Data write speed is faster than display.

10.3.10. Sub Panel Control

S6E63D6 support sub panel control function which controls sub panel driver IC using 80-mode protocol (CSB, RS, WRB & DB). When MDDI host (Base band modem) sends several packets to S6E63D6, if the packet is for sub panel, the IC converts the packet to 80-mode protocol & sends them to sub panel driver IC. So separated line for sub panel control are not needed. After all, S6E63D6 enables the sub panel driver IC which doesn't support MDDI to be applied to the system. S6E63D6 supports only 9/8 bit format for sub panel control.

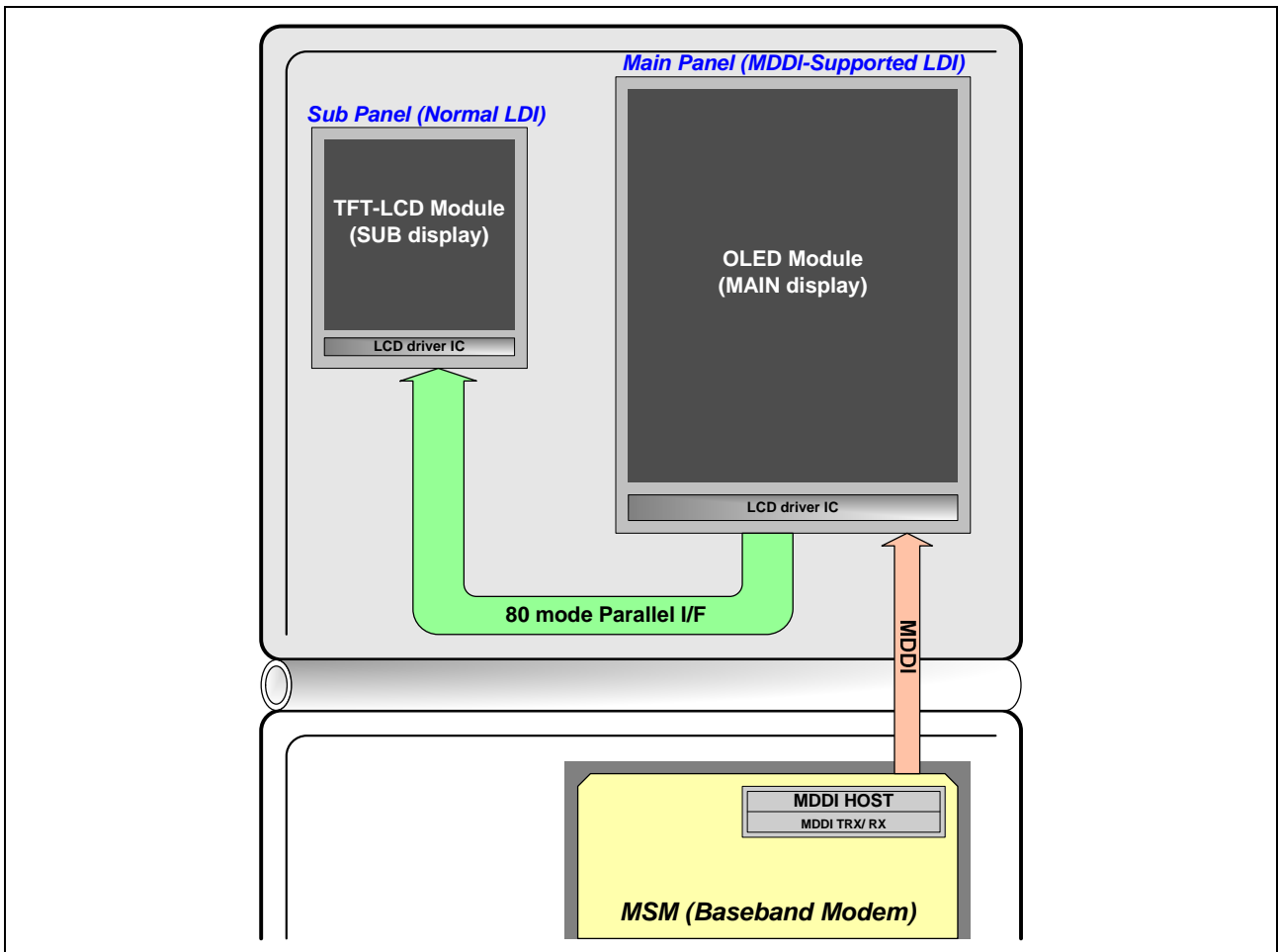

Figure 80. Schematic Diagram of Sub Panel Control Function

10.3.10.1. Main / Sub Panel Selection

Using 7Ah register (7Ah address can be changed using SUB_SEL register), main / sub panel data path can be selected.

When S6E63D6 receives register access packet (Initially 7Ah index) from MDDI host, it decodes the packet and checks the last bit of the register data field is '1' or '0'. If the last bit is '0', the following register access packet or video stream packet is transferred to the sub panel control signal generation block.

Sub panel selection address (Initially 7Ah) can be changed using SUB_SEL register. Do not change the SUB_SEL value to previously occupied address.

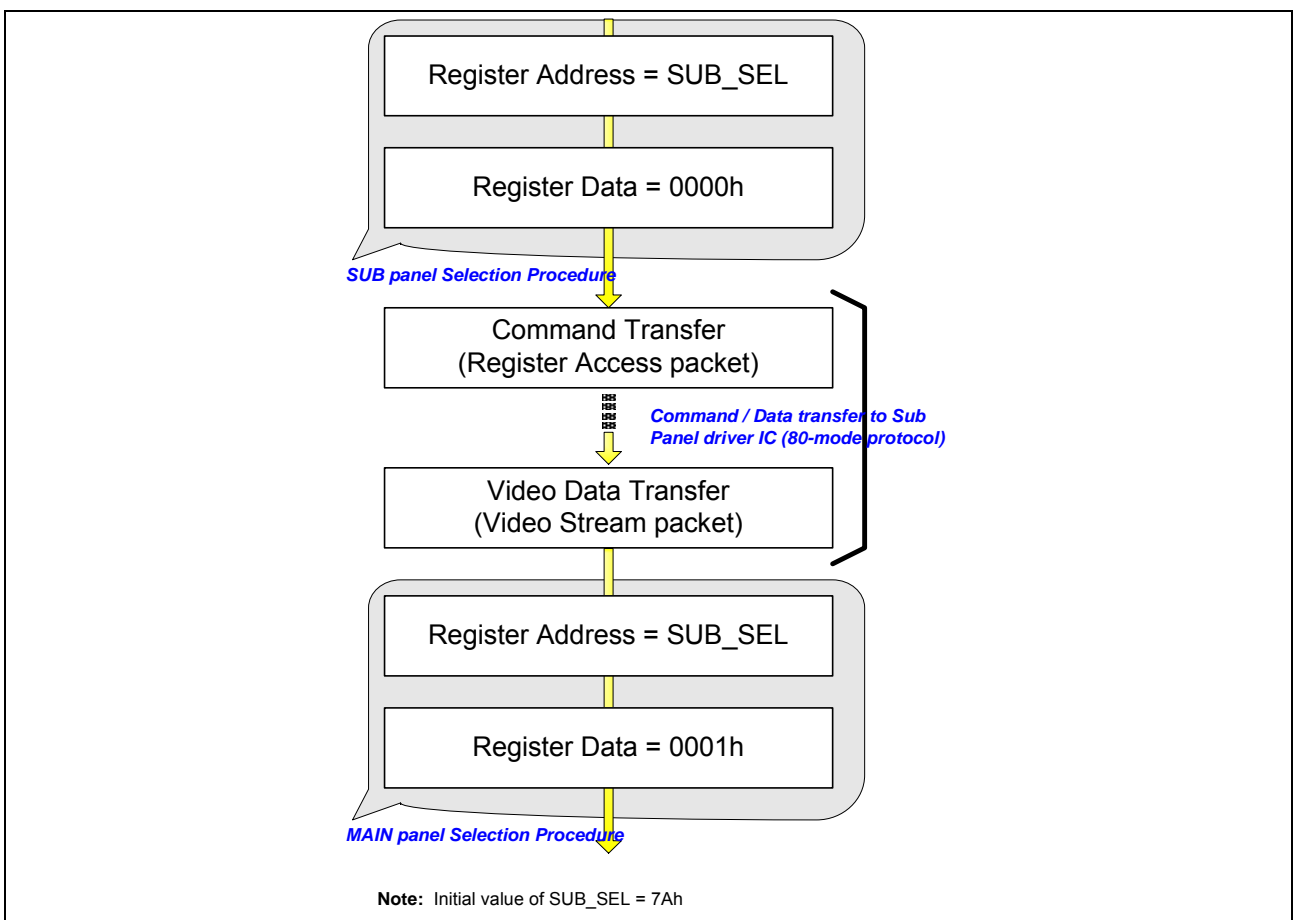

Figure 81. Main / Sub Panel Selection Procedure

When video data is transferred to the sub panel driver IC via S6E63D6, additional GRAM access command (normally 22h) is automatically generated in S6E63D6.

10.3.10.2. Sub Panel Control Timing

TFT type sub panel timing

TFT type register data transfer timing

If sub panel is selected, and sub panel type is TFT, register setting is executed like below figure.

Register data is transferred through S_DB[8:1] in 9/8 bit type. Refer to sub panel control(3Ch index) section.

In 9/8 bit mode, S_DB[8:1] is used. In this mode, data is transferred at two times. First transfer is MSB 8bit and second transfer is LSB 8bit.

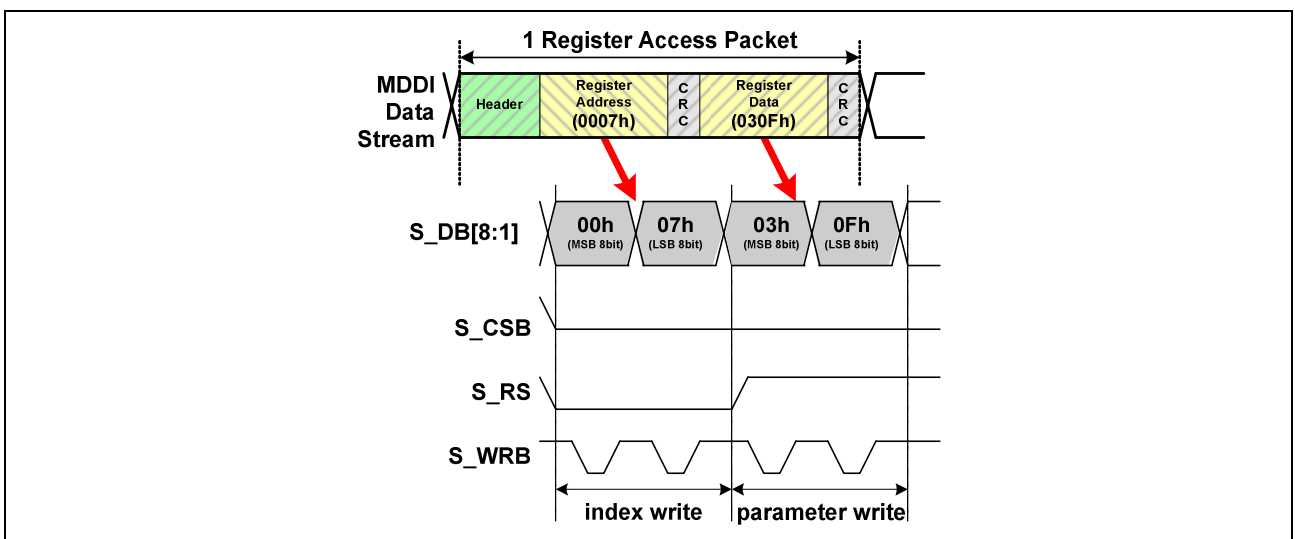

Figure 82. 80 Mode TFT Type 9-/8-bit Register Access Data Transfer

In 68 mode, S_WRB must be connected to E_RDB of sub panel module. RW_WRB of sub panel module must be tied to VSS, because S6E63D6 writes data to sub panel module only.

TFT type video data transfer timing

In TFT type sub panel, STN_EN register in 3Ch index is “0”, and if user wants to use 68-mode interface protocol, then MPU_MODE is set to “1”. 9/8 mode is selected as setting SUB_IM register. Refer to 3Ch index description.

In 68 mode, S_WRB must be connected to E_RDB of sub panel module. RW_WRB of sub panel module must be tied to VSS, because S6E63D6 writes data to sub panel module only.

This figure shows 80-mode TFT type 9 bit video data transfer.

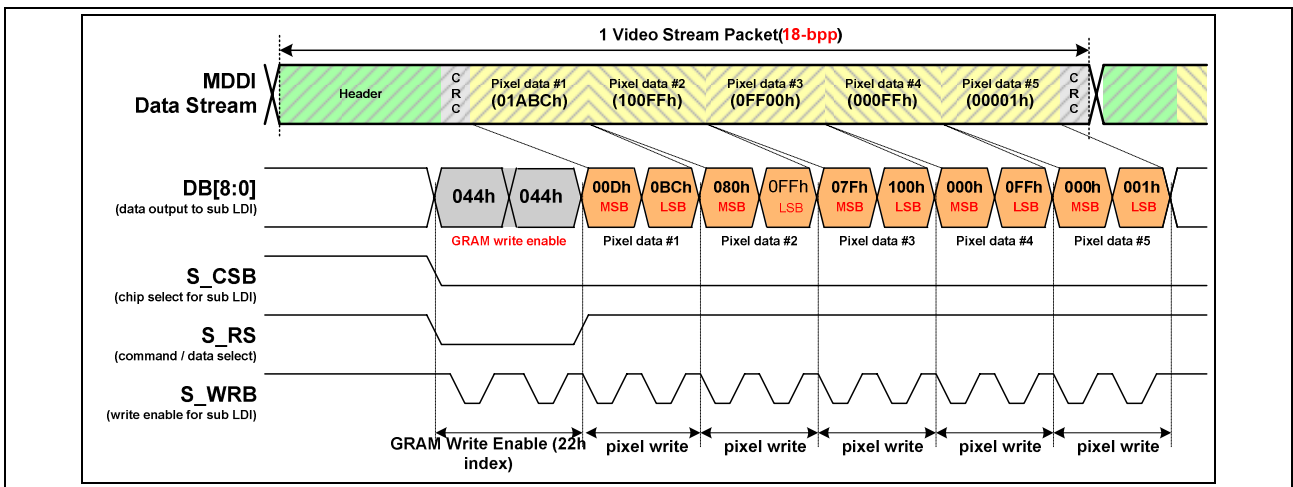

Figure 83. 80 Mode TFT Type 9-bit Video Data Transfer

This figure shows 80-mode TFT type 8 bit video data transfer.

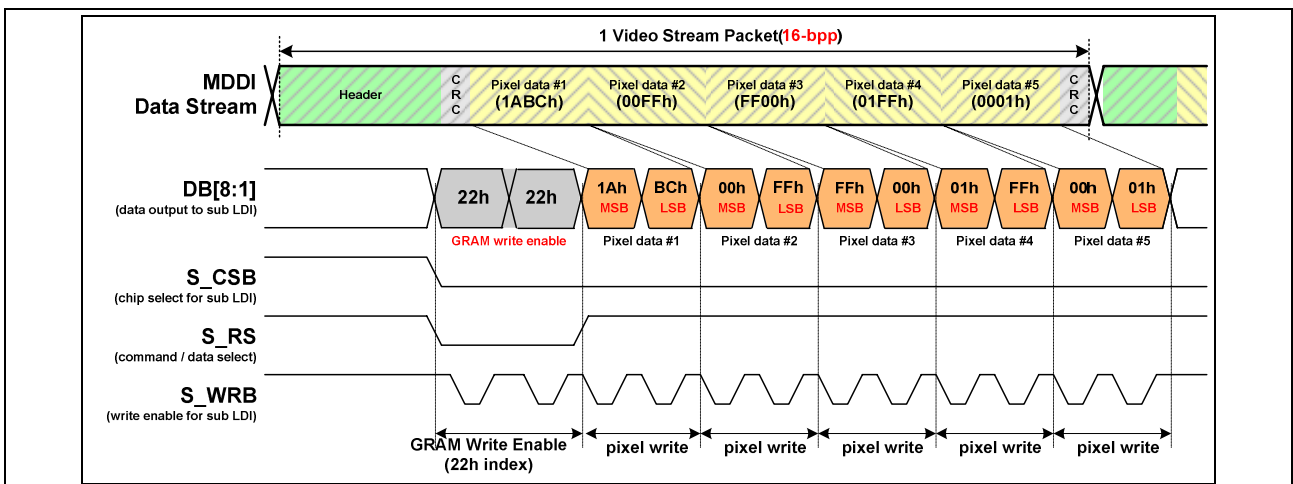

Figure 84. 80 Mode TFT Type 8-bit Video Data Transfer

STN type sub panel timing

STN type register data transfer timing

This figure shows conventional type STN mode register data setting. Conventional type does not include parameter.

Instruction type is only 8bit. To use STN type, STN_EN is set to "1". In STN type, S6E63D6 controls S_RS pad using register address[0] in register access packet. Register address[0] is "0", then S_RS is set to "0", and register address[0] is "1", S_RS is set to "1". Refer to sub panel control(3Ch index) section.

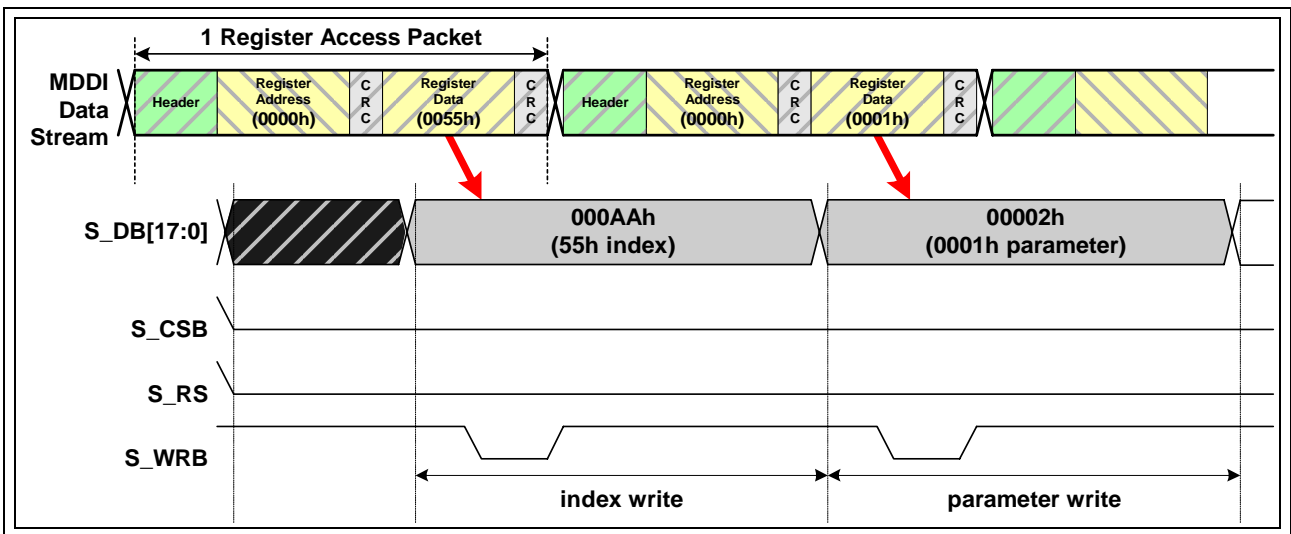

Figure 85. 80 Mode STN Type Conventional Register Data Transfer

This type is used to include parameter. When instruction is transferred, S_RS is zero, and when parameter is transferred, S_RS is "1". S_RS is controlled using register address[0] of register access packet.

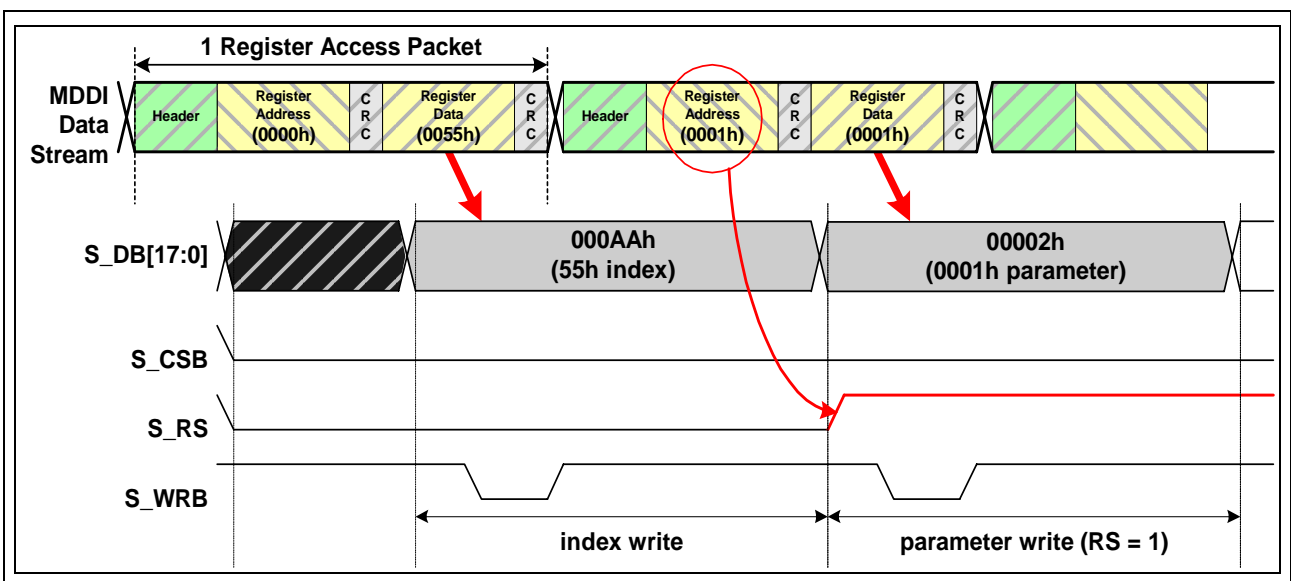

Figure 86. 80 mode STN Type Register Data Included Parameter Transfer

STN type video data transfer timing

In STN mode, video data start register (like 22H is TFT mode) does not need generally. But some STN type needs video data start register. If this type STN DDI is used, user has to set the register index.

This figure shows STN 16 bit mode video data transfer.

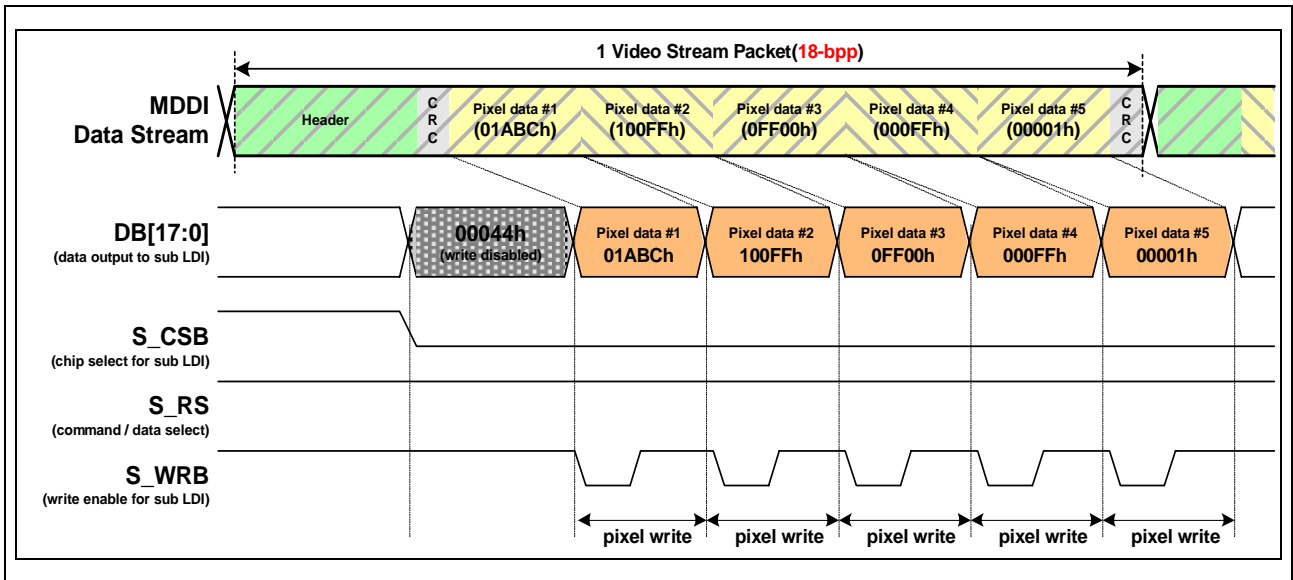

Figure 87. 80 Mode STN Type 16-bit Video Data Transfer

This figure shows STN 8bit mode video data transfer. If STN video data is 16bit mode, data transfer is executed during 2 times. First transfer is MSB 8bits, and second is LSB 8bits.

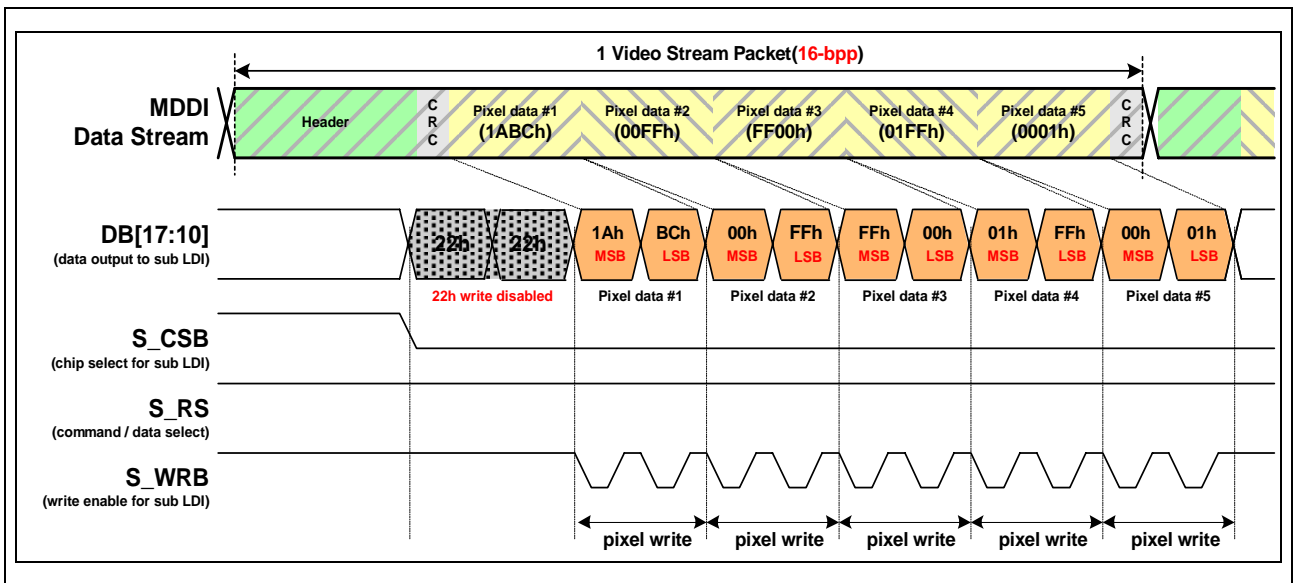

Figure 88. 80 Mode STN Type 8-bit Video Data Transfer

Index/parameter write for sub panel DDI

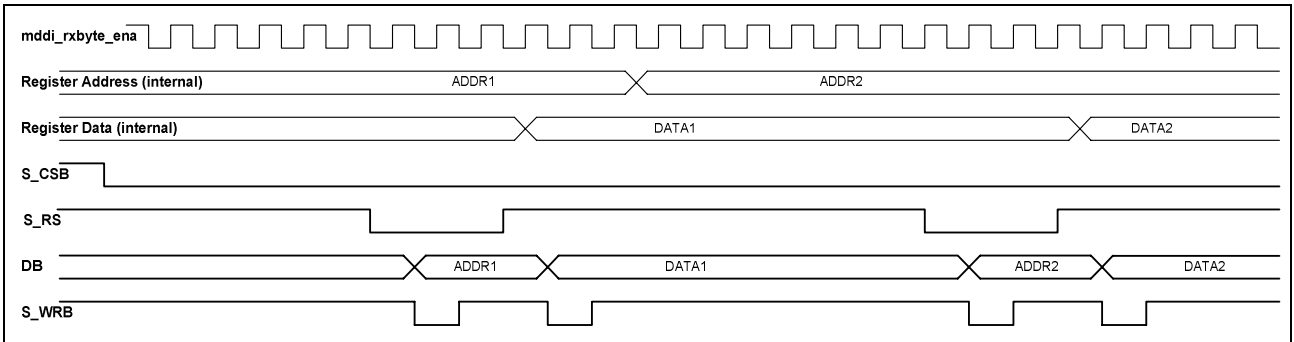

Figure 89. Index/parameter Write for Sub Panel DDI

Image data write for sub panel DDI

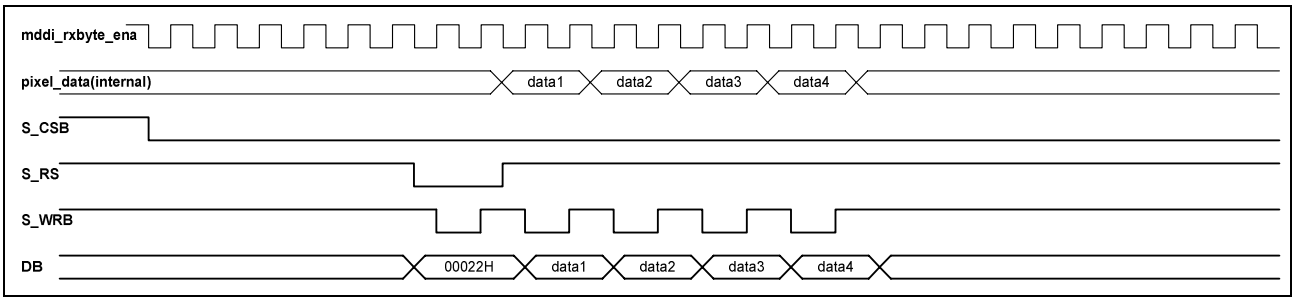

Figure 90. Image Data Write for Sub Panel DDI

Change data path from sub panel to main panel

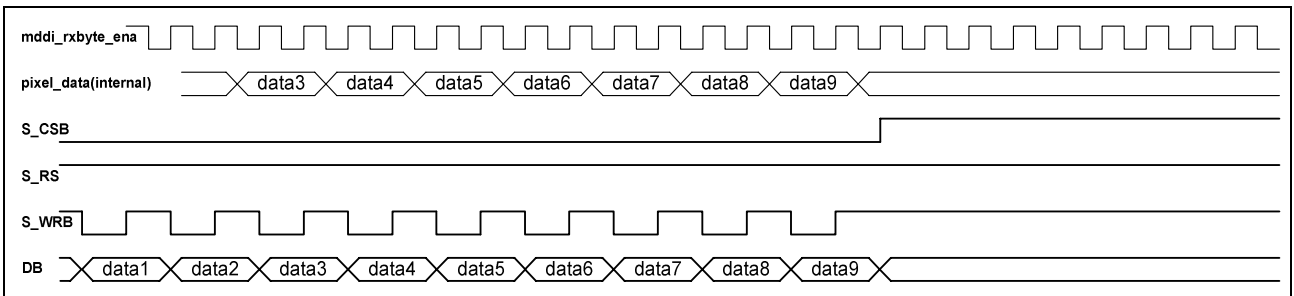

Figure 91. Change Data Path from Sub Panel to Main Panel

11. AMOLED Panel Interface

11.1. AMOLED Panel Interface Signal

S6E63D6 outputs some timing signals (SIN, CK, SCK, R_sw, G_sw, B_sw) for controlling an AMOLED panel with built-in gates. S6E63D6 has built-in level shifter for AMOLED panel. Output voltage level for high is VGH voltage, for low is VGL voltage.

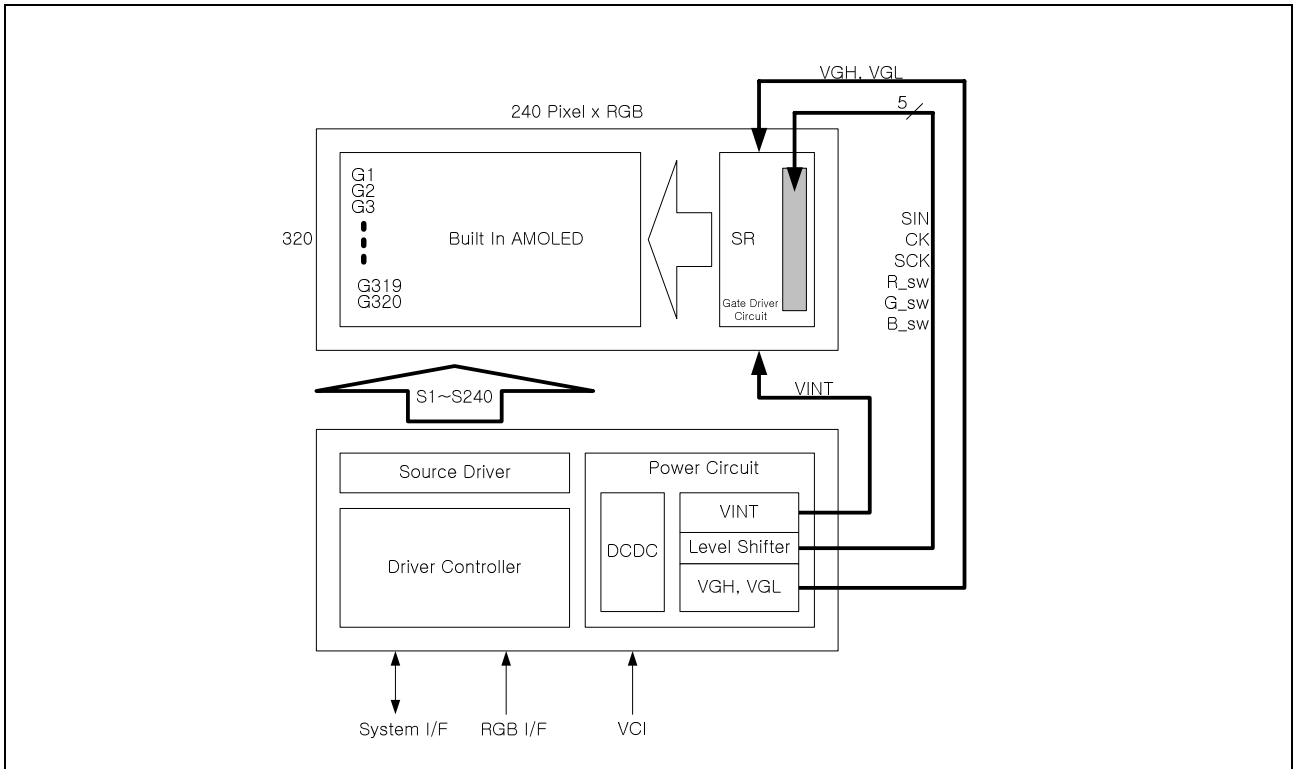

Figure 92. An Exemplary Combination of AMOLED Panel and DDI

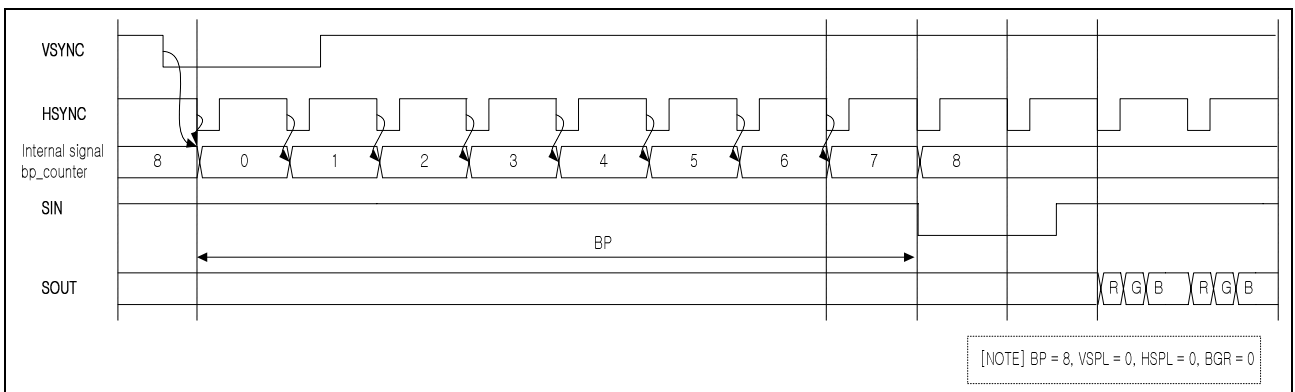

Figure 94. VSYNC and Panel Interface Signals in External Clock Operation Mode

12. R, G, B Independent Gamma Adjustment Function

S6E63D6 provides the gamma adjustment function to display 262,144 colors simultaneously.

The gamma adjustment is executed by the amplitude adjusting registers and curve adjusting registers. Since, those control registers incorporate independent adjustment of the gamma function for R, G, B independently, it is highly possible that user determine the best appropriate configuration according to the trait of the display panel.

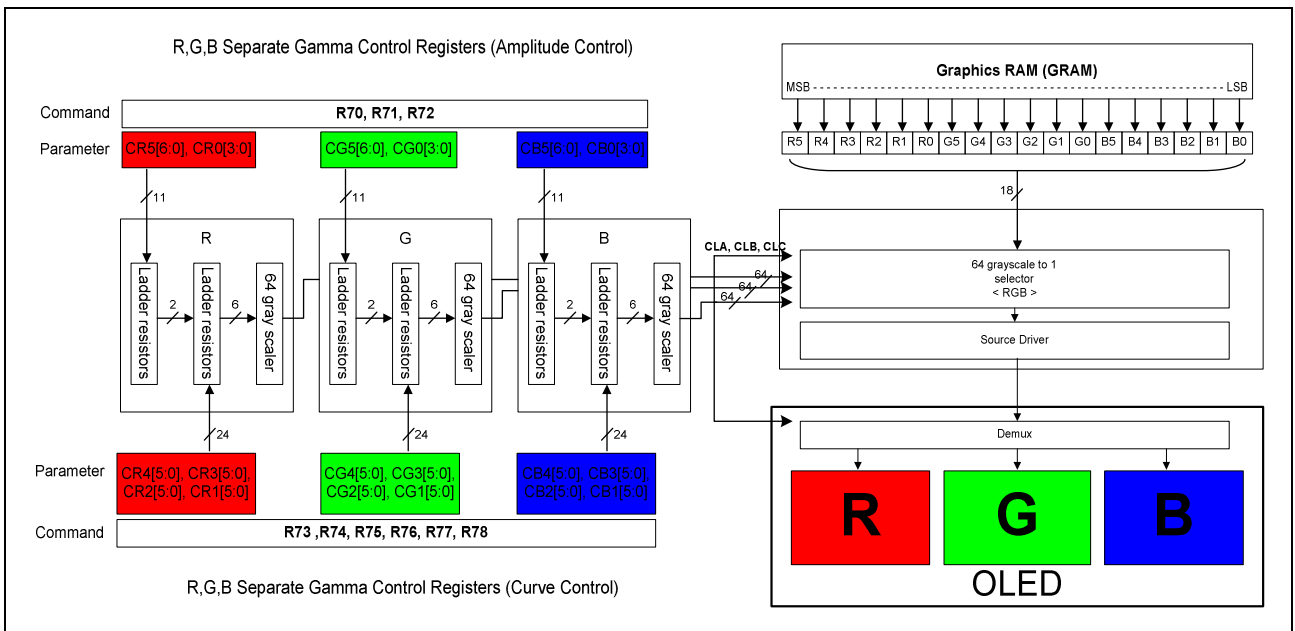

Figure 95. Grayscale Control

12.2. R, G, B Independent Gamma Adjustment Registers

These are registers to set up the grayscale voltage in accordance with the gamma specification of the AMOLED panel. The registers can set up both amplitude and curve character of grayscale voltage respectively with corresponding bits as the function of grayscale number. Each configuration can be made for R, G, B independently.

There shows the operation of each register below.

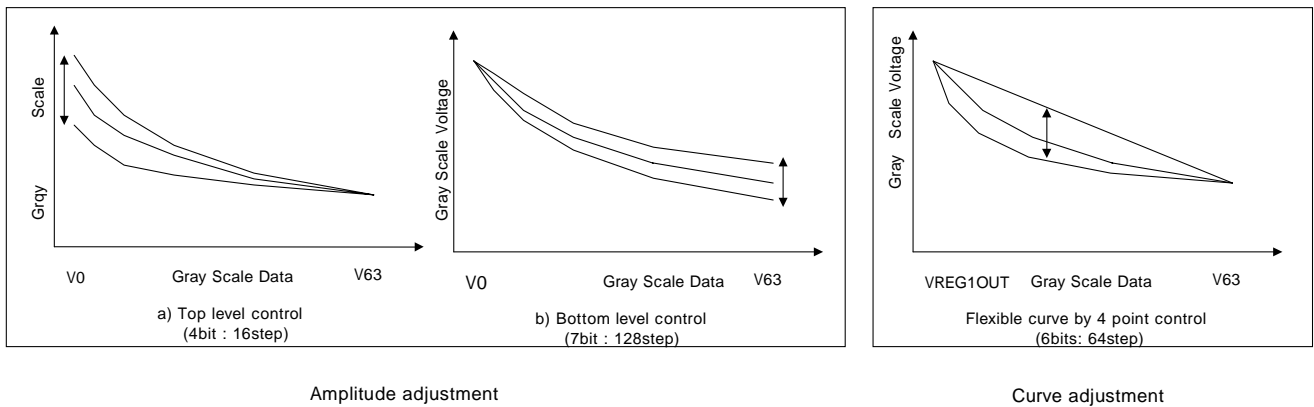

Figure 97. The Operation of Adjusting Register

12.2.1. Amplitude Adjusting Registers

These are the registers for adjusting the amplitude of grayscale voltage. The registers for adjusting amplitude consists of two parts, one of which is for top level voltage (V0) and the other of which is for bottom level voltage (V63). CR0[3:0], CG0[3:0] and CB0[3:0] registers control the top level voltage. CR5[6:0], CG5[6:0] and CB5[6:0] registers control the bottom level voltage. V0 and V63 are selected in divided voltage from ladder resistor strings between VGS and VREG1OUT. Separate registers are prepared for R, G, B respectively.

Table 69. Amplitude Adjusting Register

Register	for R	for G	for B	Content of configuration
R70H ~ R72H	CR0[3:0]	CG0[3:0]	CB0[3:0]	Grayscale voltage adjusting for top level voltage
	CR5[6:0]	CG5[6:0]	CB5[6:0]	Grayscale voltage adjusting for bottom level voltage

12.2.2. Curve Adjusting Registers

The curve adjusting registers are used for adjusting the characteristic curve of the grayscale voltage as the function of grayscale number. The registers also control R, G, B independently like the amplitude adjusting register. To accomplish the adjustment, these registers control the each 4 reference voltage by three 47 to 1 selector and a 64 to 1 selector. The 47 or 64 leveled reference voltage generated from the ladder resistor strings between V0 and V63. The registers for adjusting curve consist of 4 reference point – V4, V10, V21 and V42.

Table 72. Gamma Curve Adjusting Register

Register	For R	for G	for B	Content of configuration
R73H ~ R78H	CR1[5:0]	CG1[5:0]	CB1[5:0]	Grayscale voltage adjusting for V4
	CR2[5:0]	CG2[5:0]	CB2[5:0]	Grayscale voltage adjusting for V10
	CR3[5:0]	CG3[5:0]	CB3[5:0]	Grayscale voltage adjusting for V21
	CR4[5:0]	CG4[5:0]	CB4[5:0]	Grayscale voltage adjusting for V42

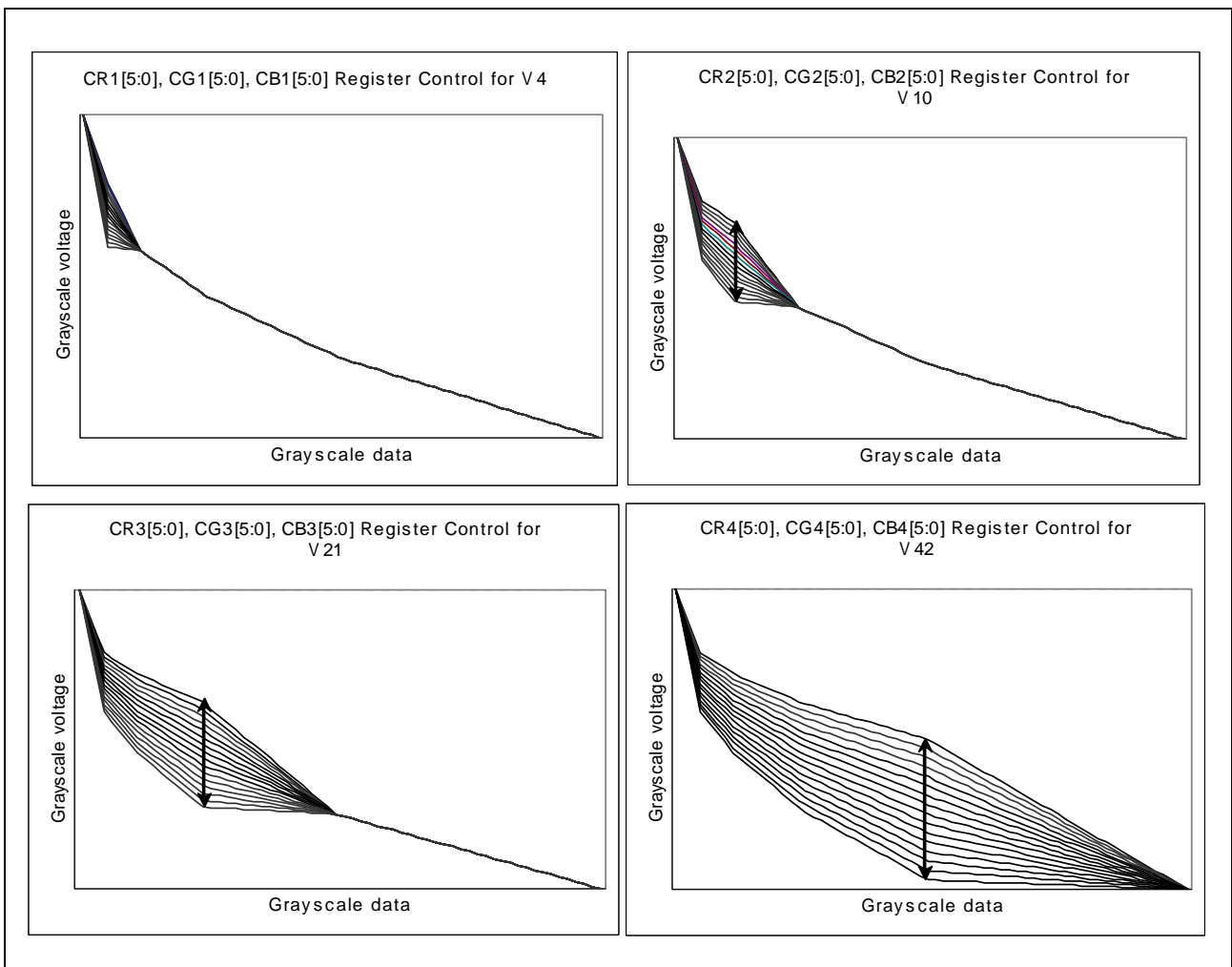

Figure 98. Gamma Curve Adjustment

12.4. Output Level as the function of GRAM Data

Output level could be described as the function of GRAM DATA like below.

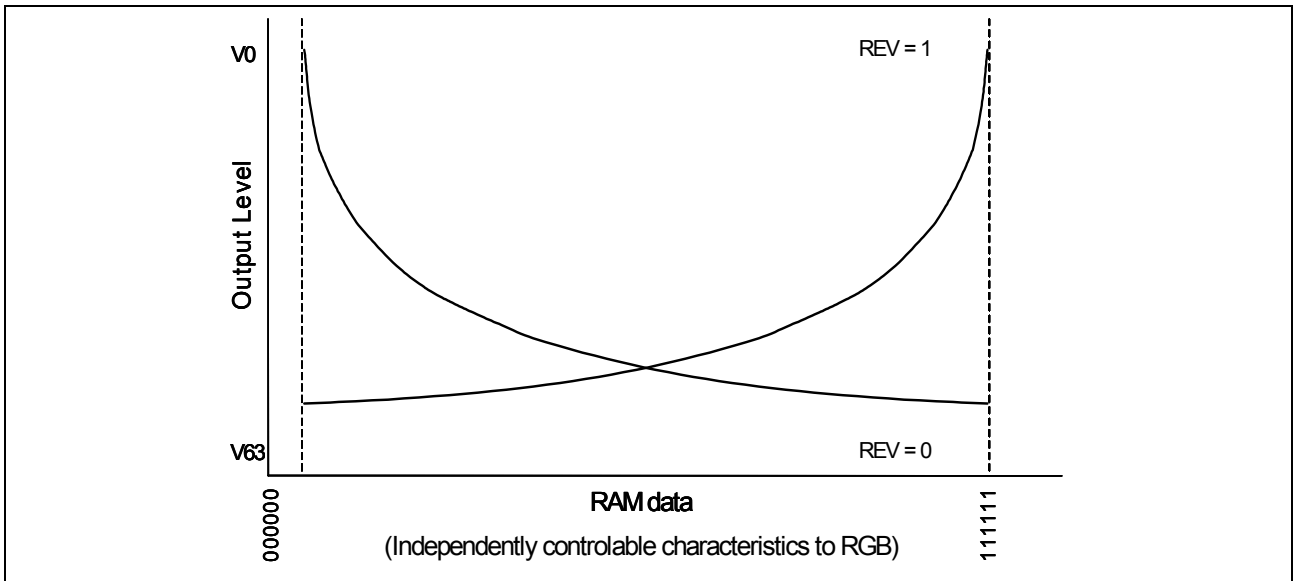

Figure 99. Relationship between RAM Data and Output Voltage

Table 75. GRAM Data and Gray Scale Level

GRAM data	Grayscale		GRAM data	Grayscale		GRAM data	Grayscale		GRAM data	Grayscale	
	REV=0	REV=1		REV=0	REV=1		REV=0	REV=1		REV=0	REV=1
000000	V0	V63	010000	V16	V47	100000	V32	V31	110000	V48	V15
000001	V1	V62	010001	V17	V46	100001	V33	V30	110001	V49	V14
000010	V2	V61	010010	V18	V45	100010	V34	V29	110010	V50	V13
000011	V3	V60	010011	V19	V44	100011	V35	V28	110011	V51	V12
000100	V4	V59	010100	V20	V43	100100	V36	V27	110100	V52	V11
000101	V5	V58	010101	V21	V42	100101	V37	V26	110101	V53	V10
000110	V6	V57	010110	V22	V41	100110	V38	V25	110110	V54	V9
000111	V7	V56	010111	V23	V40	100111	V39	V24	110111	V55	V8
001000	V8	V55	011000	V24	V39	101000	V40	V23	111000	V56	V7
001001	V9	V54	011001	V25	V38	101001	V41	V22	111001	V57	V6
001010	V10	V53	011010	V26	V37	101010	V42	V21	111010	V58	V5
001011	V11	V52	011011	V27	V36	101011	V43	V20	111011	V59	V4
001100	V12	V51	011100	V28	V35	101100	V44	V19	111100	V60	V3
001101	V13	V50	011101	V29	V34	101101	V45	V18	111101	V61	V2
001110	V14	V49	011110	V30	V33	101110	V46	V17	111110	V62	V1
001111	V15	V48	011111	V31	V32	101111	V47	V16	111111	V63	V0

13. 8-Color Display Mode

The S6E63D6 incorporates 8-color display mode. The voltage levels to be used are VREG1OUT and V63 and all the other grayscale levels V0~V62 are halt. So that it attempts to lower power consumption. During the 8-color mode, the Gamma micro adjustment register, C1R~C4R, C1G~C4G and C1B~C4B are invalid. The level power supply (V0-V62) is in OFF condition during the 8-color mode in order to select VREG1OUT/V63.

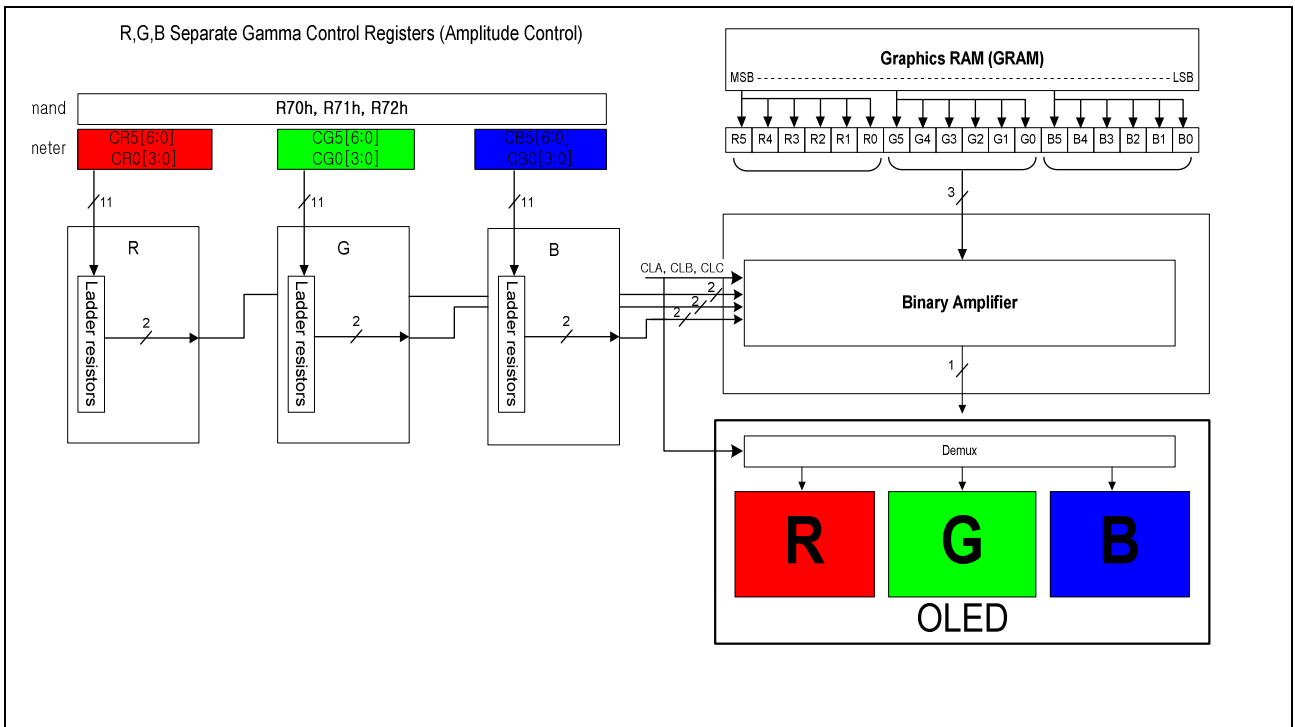

Figure 100. 8-color Display Control

14. Set-up Flow of Stand by

The figure shows set-up flow of stand by.

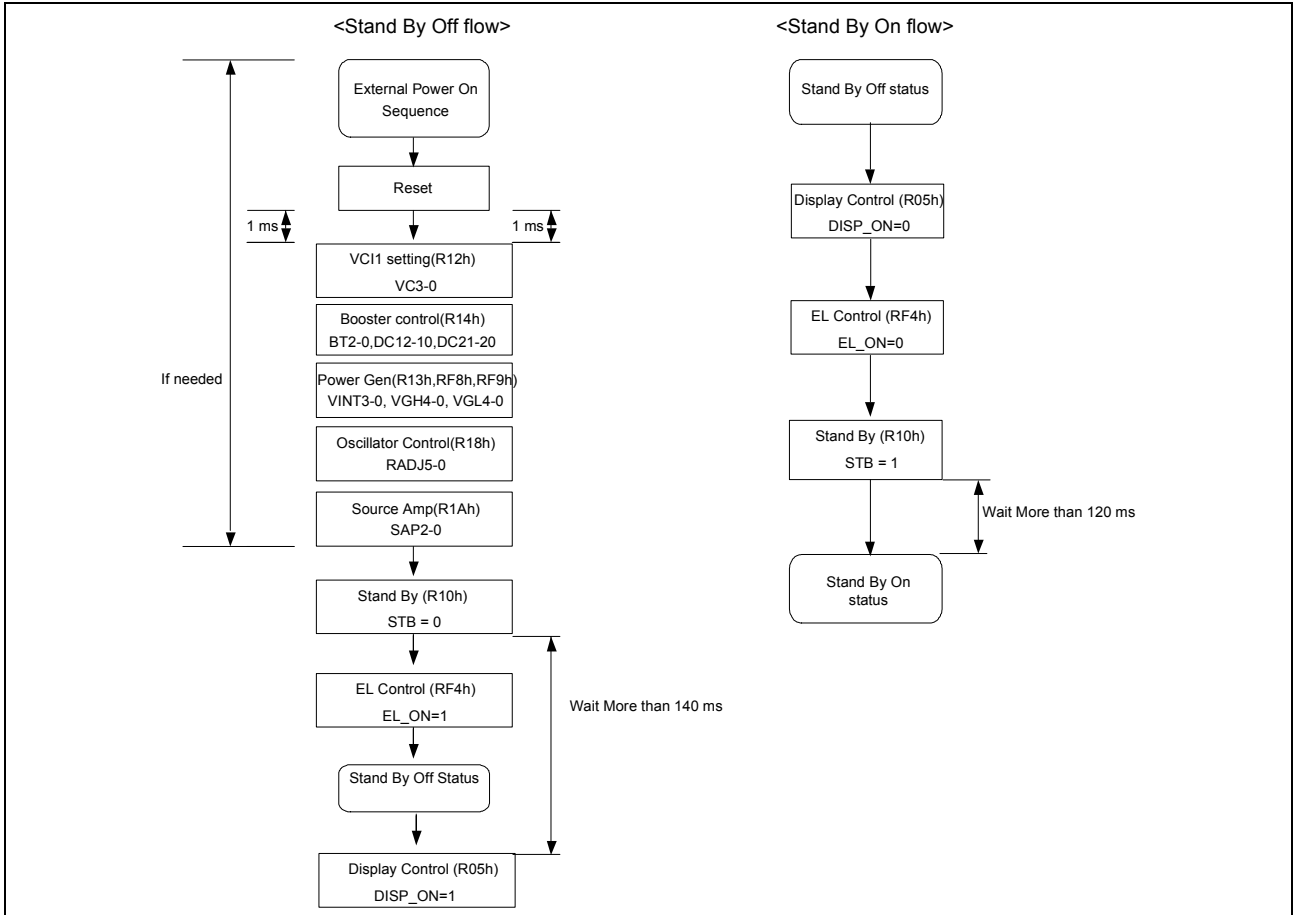

Figure 101. Set-up Flow of Stand by

15. Oscillation Circuit

The S6E63D6 can provide R-C oscillation. S6E63D6 internal oscillator does not need to attach the external resistor. The appropriate oscillation frequency for operating voltage, display size, and frame frequency can be obtained by adjusting the oscillator frequency control register setting. Since R-C oscillation stops during the standby mode, power consumption can be reduced.

Frame Frequency Calculation

The relation between the AMOLED driver duty and the frame frequency can be found by the following expression.

$$\text{Frame Frequency} = \frac{f_{osc}}{64 \times (\text{Line Number} + \text{BP} + \text{FP})}$$

f_{osc} : R-C Oscillation Frequency
 Line Number : Number of lines specified by NL
 FP : The number of lines for Front Porch (FP)
 BP : The number of lines for Back Porch (BP)

Figure 102. Formula for the Frame Frequency

Table 76. Example of Frame Frequency Calculation

Parameters	Description
Line Number	320
Frame Frequency	60
BP	8
FP	8
Fosc	1,290,240 Hz

Table 77. Display Clock Frequency

Clock Operatin Mode	1 HCLK	1 Horizontal Period
Internal Clock Operation	Fosc / 2	32 HCLKs
External Clock Operation	Fdotclk / 8(RIM=00,01) Fdotclk/24(RIM = 10)	32 HCLKs

17. DC / AC Specification

17.1. Absolute Maximum Rating

Table 78. Absolute Maximum rating

(VSS = 0V)

Item	Symbol	Rating	Unit
Supply voltage	VDD3	-0.3 ~ 5.0	V
Supply voltage for booster circuit	VCI	-0.3 ~ 5.0	V
Supply Voltage range	VLIN2 – VLIN3	20	V
Input Voltage range	Vin	-0.3 to VDD + 0.5	V

Note

1. Absolute maximum rating is the limit value. When the IC is exposed operating environment beyond this range, the IC does not assure operations and may be damaged permanently, not be able to be recovered.
2. Absolute maximum rating is guaranteed only when our company's package used.

17.2. DC Characteristics

Table 79. DC Characteristics 1

(Ta = -40 ~ 85 , VSS = 0V)

Characteristic	Symbol	CONDITION	MIN	TYP	MAX	Unit	Note
Driving voltage	VGH	-	3.0	-	8.0	V	
	VGL	-	-8.0	-	-3.0	V	
	VINT	-	-4.0	-	-1.0	V	
Logic Operating Voltage	RVDD	-	1.45	1.5	1.55	V	
Operating frequency	fosc	Frame frequency = 60Hz Display line = 320 line	1161.1	1290.2	1419.3	kHz	
1st booster input voltage	VCI1	-	2.1	-	2.75	V	
1st booster output voltage	VLOUT1	Without load	+4.6	-	+5.5	V	
1st booster output efficiency	VLOUT1	I _{VLOUT1_LOAD} = 2.3mA	90	95	-	%	
2nd booster output voltage	VLOUT2	Without load		7.8		V	
2nd booster output efficiency	VLOUT2	I _{VLOUT2_LOAD} = 0.1mA	90	93	-	%	
3rd booster output voltage	VLOUT3	Without load	-	-10.6	-	V	
3rd booster output efficiency	VLOUT3	I _{VLOUT3_LOAD} = 0.1mA	90	93	-	%	
Source Output voltage deviation (channel to channel)	-	-	-	±5	-	mV	
Source Output voltage difference (nearest channel)	-	20 Gray Pattern	-	5	-	mV	
Output voltage deviation (Chip to Chip)	-	-	-	±15	-	mV	
Source driver output voltage range	Vso	-	0.3	-	4.2	V	
Driving voltage	dVGH	voltage deviation	-	-	300	mV	
	dVGL	voltage deviation	-	-	300	mV	
Current consumption during normal operation	IVDD3	No load, Ta = 25 °C	-	1.0	5.0	uA	*1
	IVCI		-	3.5	4.0	mA	
Stand by mode current	IVDD3	Ta = 25 °C	-	0.1	5.0	uA	
	IVCI		-	10	20	uA	

Note

1. VDD3=1.8V, VCI=2.8V, fosc=1290.2KHz (320 display line), NL[5:0]="10_1000", SAP[2:0]="101", DC22[2:0]="100", DC12[2:0]="010", BT[1:0]=10, VC[3:0]="1000", VGH[4:0]="10100", VGL[4:0]="10100", VINT[3:0]="0101"

Table 80. DC Characteristics 2

(Ta = -40 ~ 85 , VSS = 0V)

Characteristic	Symbol	CONDITION	MIN	TYP	MAX	Unit	Note
Power Supply Voltage	VCI	Operating Voltage	2.5	2.8	3.3	V	
Power Supply Voltage	VDD3	I/O supply Voltage	1.65	1.8	3.3	V	
Logic High level input voltage	V _{IH}		0.7*VDD3		VDD3	V	
Logic Low level input voltage	V _{IL}		0.0		0.3*VDD3	V	
Logic High level output voltage	V _{OH}	IOUT = -1mA	0.8*VDD3		VDD3	V	
Logic Low level output voltage	V _{OL}	IOUT = +1mA	0.0		0.2*VDD3	V	
Analog High level output voltage	EL_ON _{OH}	8uA	1.8		VCI	V	
Analog Low level output voltage	EL_ON _{OL}	8uA	0		0.3	V	

Table 81. DC Characteristics 3

(VDD3 = 1.65~3.3V, VCI = 2.5~3.3V, Ta = 25)

Characteristic	Symbol	CONDITION	MIN	TYP	MAX	Unit	Note
VREG1OUT		.	4.185	4.2	4.215	V	



ELECTRONICS

17.5. AC Characteristics

17.5.1. AC Characteristics on System Interface (Parallel 68 Mode)

Table 84. Parallel Interface AC Characteristics (68 Mode)

(VDD = 1.5V, VDD3 = 1.65 to 3.3V, TA = -40 to +85°C)

Characteristic		Symbol	Specification		Unit
			Min.	Max.	
Cycle time	Write	tCYCW68	85	-	ns
	Read	tCYCR68	500	-	ns
Pulse rise / fall time		tR, tF	-	15	ns
Pulse width low	Write	tWLW68	27.5	-	ns
	Read	tWLR68	250	-	ns
Pulse width high	Write	tWHW68	27.5	-	ns
	Read	tWHR68	250	-	ns
RS,RW to CSB, E setup time		tAS68	10	-	ns
RS,RW to CSB, E hold time		tAH68	2	-	ns
CSB to E time		tCW68	15	-	ns
Write data setup time		tWDS68	40	-	ns
Write data hold time		tWDH68	15	-	ns
Read data delay time		tRDD68	-	200	ns
Read data hold time		tRDH68	5	-	ns

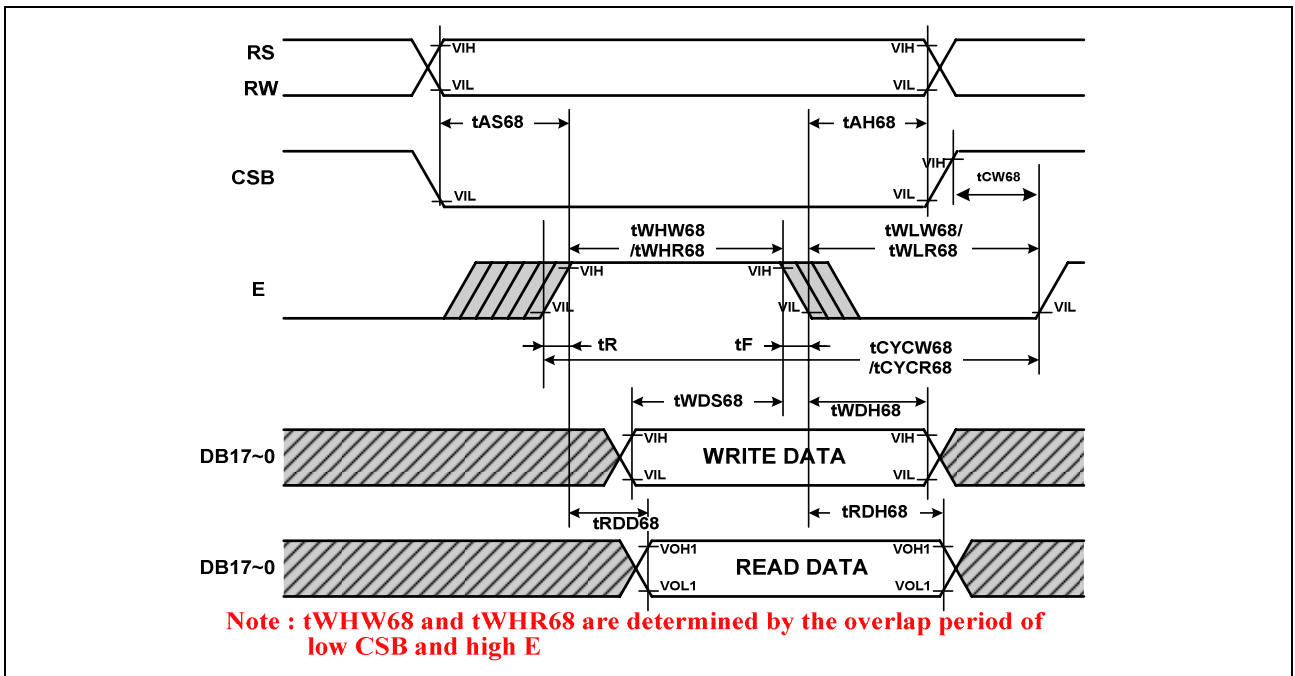

Figure 107. AC Characteristics (68 Mode)

17.5.2. AC Characteristics on System Interface (Parallel 80 Mode)

Table 85. Parallel Interface AC Characteristics (80 Mode)

(VDD = 1.5V, VDD3 = 1.65 to 3.3V, TA = -40 to +85°C)

Characteristic		Symbol	Specification		Unit
			Min.	Max.	
Cycle time	Write	tCYCW80	85	-	ns
	Read	tCYCR80	500	-	ns
Pulse rise / fall time		tR, tF	-	15	ns
Pulse width low	Write	tWLW80	27.5	-	ns
	Read	tWLR80	250	-	ns
Pulse width high	Write	tWHW80	27.5	-	ns
	Read	tWHR80	250	-	ns
RS to CSB, WRB(RDB) setup time		tAS80	10	-	ns
RS to CSB, WRB(RDB) hold time		tAH80	2	-	ns
CSB to WRB(RDB) time		tCW80	15	-	ns
Write data setup time		tWDS80	40	-	ns
Write data hold time		tWDH80	15	-	ns
Read data delay time		tRDD80	-	200	ns
Read data hold time		tRDH80	5	-	ns

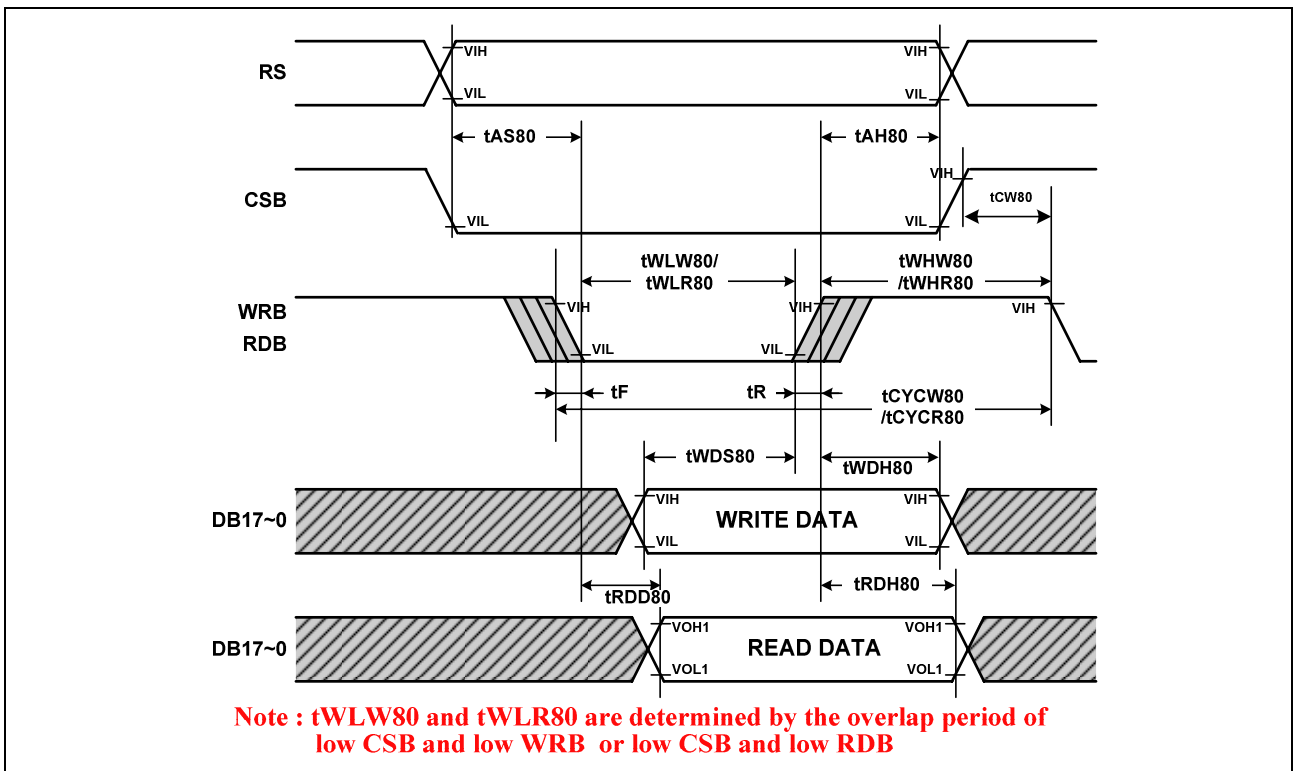

Figure 108. AC Characteristics (80 Mode)

17.5.3. AC Characteristics on System Interface (SPI)

Table 86. SPI AC Characteristics

(VDD = 1.5V, VDD3 = 1.65 to 3.3V, TA = -40 to +85°C)

Characteristic	Symbol	Specification		Unit
		Min.	Max.	
Serial clock write cycle time	tSCYC	130	-	ns
Serial clock read cycle time	tSCYC	250	-	ns
Serial clock rise / fall time	tR, tF	-	15	ns
Pulse width high for write	tSCHW	50	-	ns
Pulse width high for read	tSCHR	110	-	ns
Pulse width low for write	tSCLW	50	-	ns
Pulse width low for read	tSCLR	110	-	ns
Chip select setup time	tCSS	20	-	ns
Chip select hold time	tCSH	60	-	ns
Serial input data setup time	tSIDS	30	-	ns
Serial input data hold time	tSIDH	30	-	ns
Serial output data delay time	tSODD	-	130	ns
Serial output data hold time	tSODH	5	-	ns

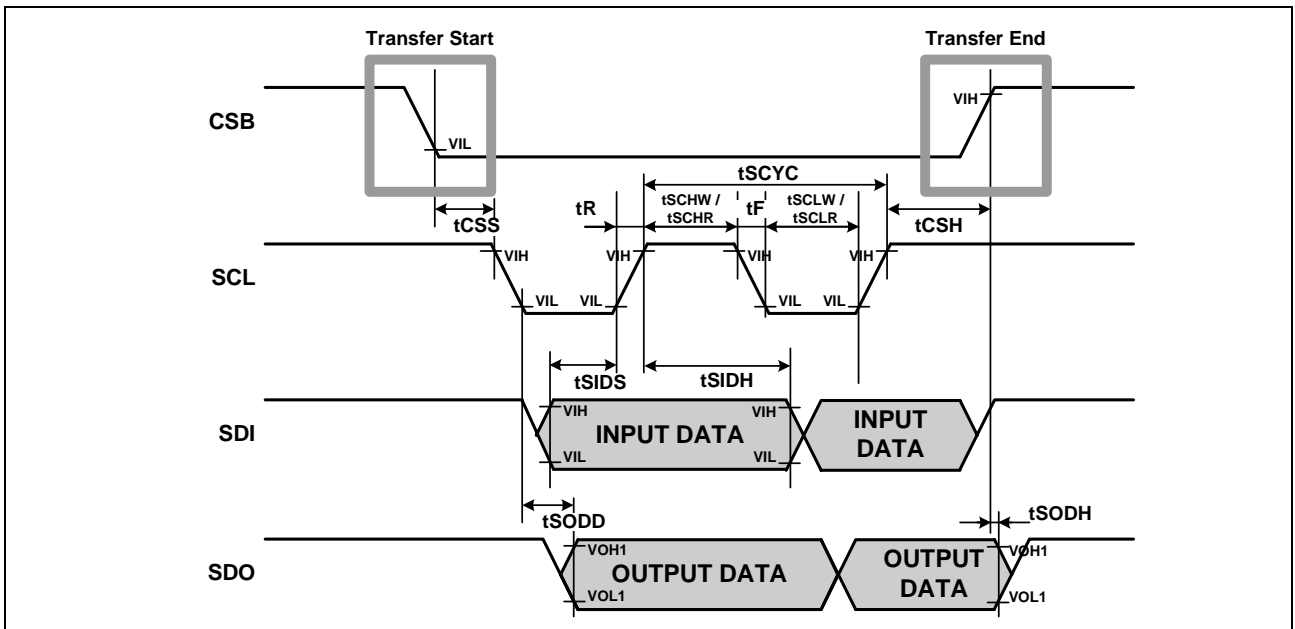

Figure 109. AC Characteristics (SPI Mode)

17.5.4. AC Characteristics on RGB Interface

Table 87. RGB Interface AC Characteristics

(VDD = 1.5V, VDD3 = 1.65 to 3.3V, TA = -40 to +85°C)

Characteristic	Symbol	Specification		Unit		Unit
		Min.	Max.	Min.	Max.	
DOTCLK cycle time	tDCYC	100	-	55	-	ns
DOTCLK rise / fall time	tR, tF	-	15	-	15	ns
DOTCLK pulse width high	tDCHW	40	-	25	-	ns
DOTCLK pulse width low	tDCLW	40	-	25	-	ns
Vertical sync setup time	tVSYS	30	-	30	-	ns
Vertical sync hold time	tVSYH	30	-	30	-	ns
Horizontal sync setup time	tHSYS	30	-	30	-	ns
Horizontal sync hold time	tHSYH	30	-	30	-	ns
ENABLE setup time	tENS	30	-	30	-	ns
ENABLE hold time	tENH	20	-	20	-	ns
PD data setup time	tPDS	30	-	30	-	ns
PD data hold time	tPDH	20	-	20	-	ns
HSYNC-ENABLE time	tHE	1	HBP	1	HBP	tDCYC
VSYSNC-HSYNC time	tHV	1	175	1	527	tDCYC

Note

1. HBP is horizontal back-porch.

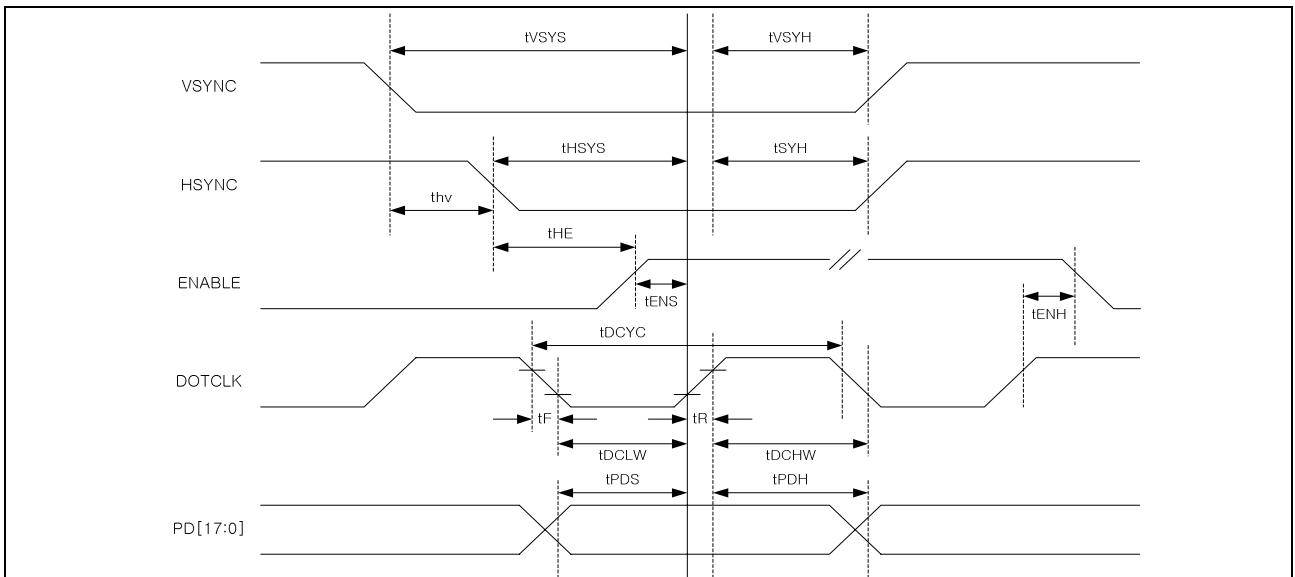

(When VSPL=0, HSPL=0, DPL=0, EPL=1)

Figure 110. AC Characteristics (RGB Interface Mode)

17.6. MDDI IO DC / AC Characteristics

Table 88. Data / Strobe Rx DC Characteristics

Parameter	Description	MIN	TYP	MAX	Unit	Note
V_{IT+}	Receiver differential input high threshold voltage. Above this differential voltage the input signal shall be interpreted as a logicone level.			50	mV	
V_{IT-}	Receiver differential input low threshold voltage. Below this differential voltage the input signal shall be interpreted as a logiczero level.	-50			mV	
V_{IT+}	Receiver differential input high threshold voltage (offset for hibernation wake-up). Above this differential voltage the input signal shall be interpreted as a logic-one level.		125	175	mV	
V_{IT-}	Receiver differential input low threshold voltage (offset for hibernation wake-up). Below this differential voltage the input signal shall be interpreted as logic-zero level.	75	125		mV	
$V_{Input-Range}$	Allowable receiver input voltage range with respect to client ground.	0		1.65	V	
R_{term}	Parallel termination resistance value	98	100	102		

Table 89. Data / Strobe Rx AC Characteristics

Parameter	Description	MIN	TYP	MAX	Unit	Note
V_{IT+}	Receiver differential input high threshold voltage in AC condition.			100	mV	
V_{IT-}	Receiver differential input low threshold voltage in AC condition.	-100			mV	

Table 90. Driver Electrical DC Characteristics

Parameter	Description	MIN	TYP	MAX	Unit	Note
$I_{diffabs}$	Absolute driver differential output current range (Currnt through the termination resistor)	2.5		4.5	mA	$R_{term} = 100$
$V_{out-rng-int}$	Single-ended driver output voltage range with respect to ground, internal mode	0.35		1.60	V	Under all conditions, including double-drive

17.7. Reset Timing

The following figure shows the spec. of reset pulse pulse width.



Figure 111. AC characteristics (RESET timing)

Reset low pulse width shorter than 10us do not make reset. It means undesired short pulse such as glitch, bouncing noise or electrostatic discharge do not cause irregular system reset. Please refer to the table below

Table 91. AC characteristics (RESET timing)

Parameter	Description	Min	Max	Unit
tRES	Reset low pulse width	10	-	us

Table 92. Reset Operation Regarding tRES Pulse Width

tRES Pulse	Action
Shorter than 5 us	No reset
Longer than 10 us	Reset
Between 5 us and 10 us	Not determined

1. User may or may not use RESETB signal. In order to use it, user should satisfy the conditions described in the above tables. But when not wants to use RESETB, user may fix this pad to VDD3 level because internally generated POR (Power-On-Reset) is used.

2. Spike Rejection also applies during a valid reset pulse as shown below:

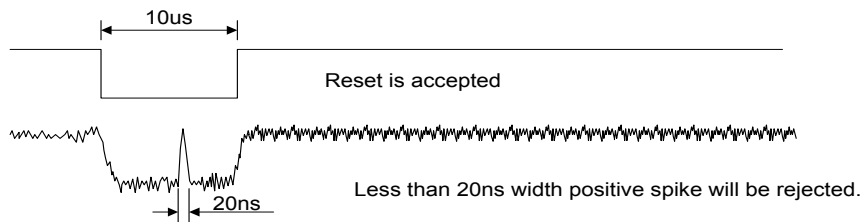

Figure 112. Spike Rejection During a Valid Reset Pulse.

17.8. External Power on / off Sequence

17.8.1. External Power On Sequence

VDD3 must be applied earlier than VCI or at least applied simultaneously with VCI. When regulator cap is 1µF, RESETB must be applied after VCI have been applied. The applied time gap between VCI and RESETB is minimum 1ms. As regulator cap becomes larger, this time gap must be increased. Otherwise function is not guaranteed.

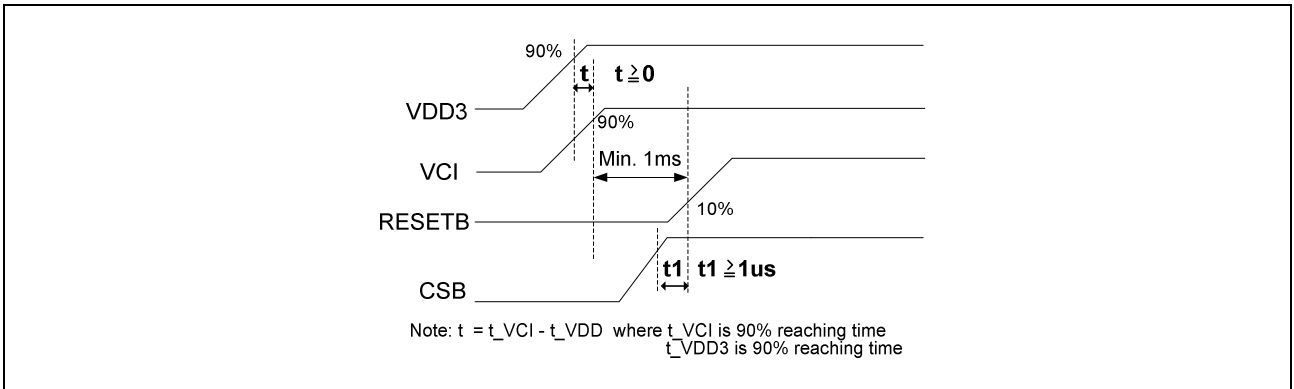

Figure 113. External Power on Sequence

17.8.2. External Power Off Sequence

VDD3 must be powered down later than VCI or at least powered down simultaneously with VCI. VCI must be powered down after RESETB have been powered down. The time gap of powered down between RESETB and VCI is minimum 1ms. Otherwise function is not guaranteed.

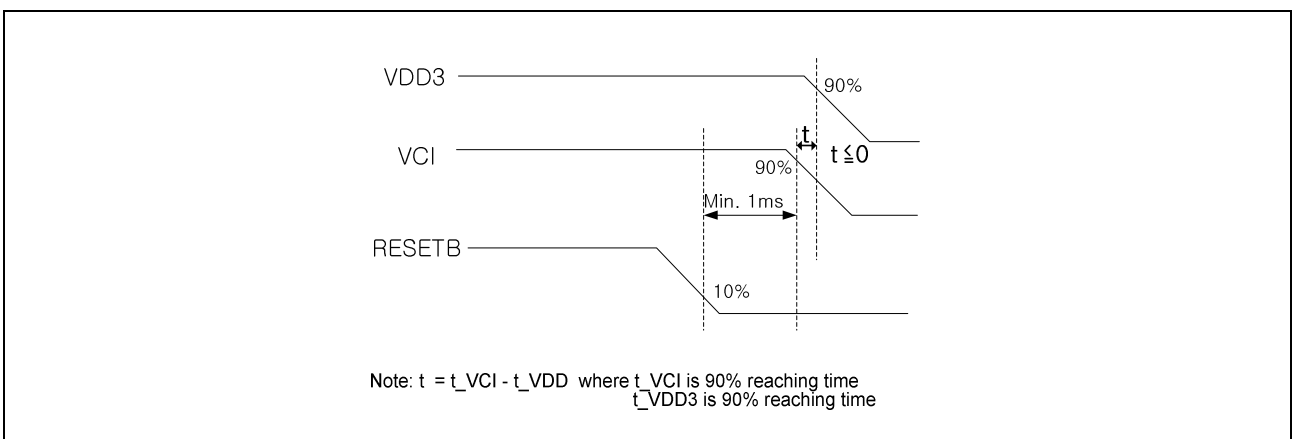

Figure 114. External Power off Sequence