

CONTENTS

Page

1 Controller, diagram 3HAC 2393-3, Rev. 0	1-73
2 Manipulator, diagram 3HAC 2803-3, Rev. 0	101-112

SHEET	OPT. NO.	CONTENTS
1		LIST OF CONTENTS
2		LIST OF CONTENTS
3	111,112	VIEW OF CONTROL CABINET
4		DESIGNATION
5		DESIGNATION
6		KEYING
7		KEYING
8		KEYING
10		BLOCK DIAGRAM
11	13X,14X,17X,43X	MAINS CONNECTION
12	150	TRANSFORMER UNIT
13		POWER SUPPLY AND I/O SUPPLY
14		EMERGENCY STOP
15	191,193	RUN CHAIN
16	14X	POWER UNIT AND SERVO DISCONNECTOR
17	65X	DRIVE SYSTEM EXTERNAL CONN. IRB 14XX/24XX
17.1	64X	DRIVE SYSTEM INTERNAL CONN. IRB 14XX/24XX
18	65X	DRIVE SYSTEM EXTERNAL CONN. IRB 44XX/64XX
18.1	64X	DRIVE SYSTEM INTERNAL CONN. IRB 44XX/64XX
18.2	20X	DRIVE SYSTEM EXTERNAL CONN. IRB 640/840
19	425,47X	FLOPPY DISC UNIT, SERIAL PORTS, BATTERIES
19.1	47X	FLOPPY DISC UNIT, SERIAL PORTS, BATTERIES
20	65X	MEASUREMENT BOARD
20.1	386,387	EXTERNES AXES MEASUREMENT BOARD
20.2	65X	CONTROL CABLES 14XX-64XX
20.3	65X	CONTROL CABLES 14XX-64XX
21	42X,43X	SERVICE EQUIPMENT SUPPLY
22	65X	EXTENSION CABLE TEACH PENDENT
23	18X	EXTERNAL CONTROL PANEL
30	381,382	EXTERNAL CUSTOMER CONNECTION
31	7X	OPTIONAL POSITION SWITCHES, MANIPULATOR
32	67X	CUSTOMER SIGNAL IRB 1400
32.1	67X	CUSTOMER POWER/SIGNAL INTERNAL IRB 2400
32.2	67X	CUSTOMER POWER/SIGNAL IRB 2400, 4400, 6400 EXTERNAL
33	5X	TIME RELAY FAN AXIS 1 (IRB6400)
35	39X	EXTERNAL AXIS CONTROL SIGNAL CONNECTION

	SHEET	OPT. NO.	CONTENTS	
I/O	40		EXTERNAL I/O CAN-BUS CONNECTION	
	41		I/O UNIT POSITION	
	42-42.1	20X,23X,25X	I/O UNIT, DIGITAL INPUTS,DIGITAL INPUT 120VAC	
	43-43.1	20X,23X,25X	I/O UNIT, DIGITAL OUTPUTS,DIGITAL OUTPUT 120VAC	
	44	23X	DIGITAL AND ANALOGUE OUTPUT PART OF COMBI I/O UNIT	
	45	26X	I/O UNIT, RELAY, DIGITAL INPUTS	
	46	26X	I/O UNIT, RELAY OUTPUT 1-9	
	47	26X	I/O UNIT, RELAY OUTPUT 9-16	
	48	22X	ANALOGUE I/O-UNIT no 1-4	
	49	690	ENCODER I/O UNIT	
	COMMUNICATION	70	281	REMOTE I/O
		71-71.1	283-287	INTERBUS-S MASTER/SLAVE/PROFIBUS
		72	292	NETWORK I/O COMPUTER
73		293	S4PC WORKSTATION	

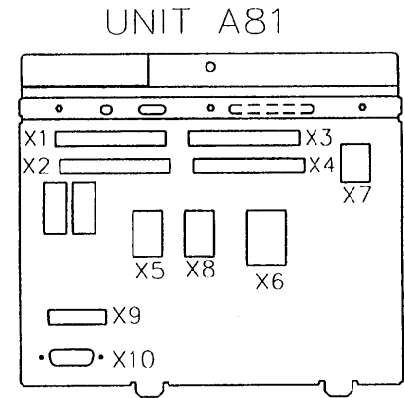
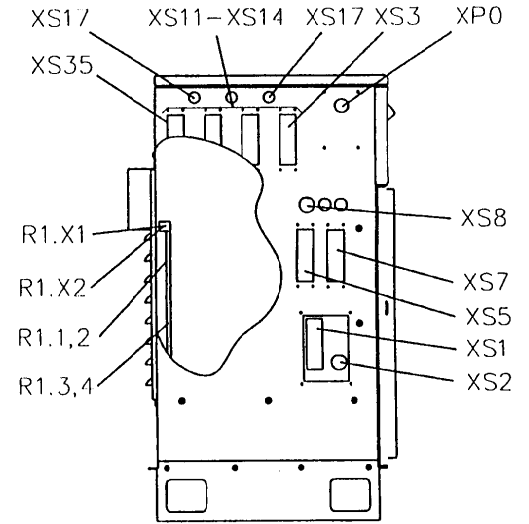
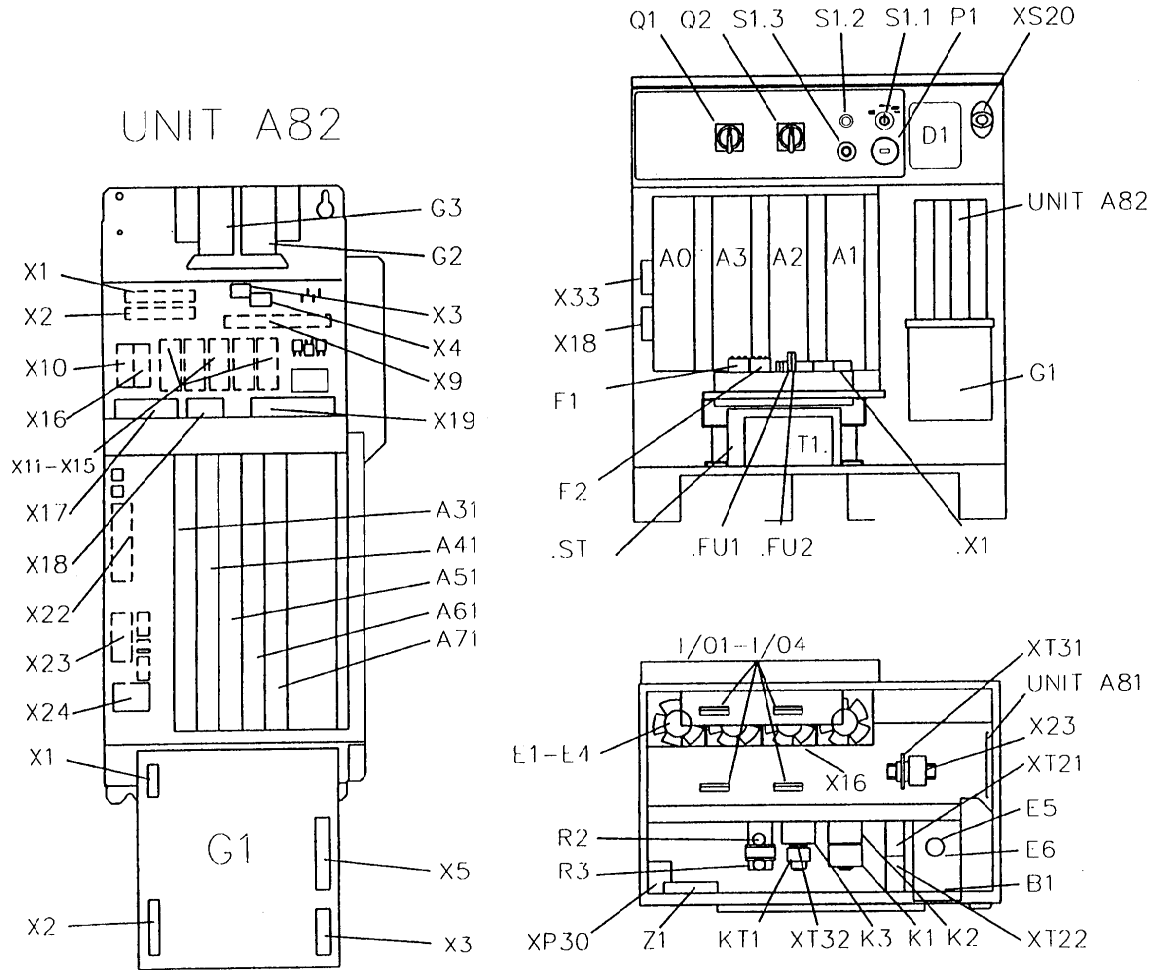

View of control cabinet

SHEET	DESIGNATION	SHEET	DESIGNATION
17,18	A0 Rectifier Drive system IRB 1400/6400	17,18	E1 Fan, Drive system IRB 4400/6400
17,18	A1 Drive unit axis IRB 1400/6400	17,18	E2 Fan, Drive system IRB 4400/6400
17,18	A2 Drive unit axis IRB 1400/6400	17,18	E3 Fan, Drive system IRB 4400/6400
18	A3 Drive unit axis IRB 4400/6400	17,18	E4 Fan, Drive system IRB 4400/6400
20.1	A19.R2SMB Serial Measurement Board	19	E5 Fan, floppy disc cooling
10	A31 Robot computer	19	E6 Peltier element
10	A41 Extended memory board	73	E7 S4PC Workstation
10	A51 Main computer	11	F1 Automatic Fuse, Mains voltage
71	A61 Netw. I/O Comp. when Interbus-S Slave M. board is installed	11	F2 Automatic Fuse, Direct supply
72	A71 Network I/O Computer or Interbus-S Slave Master board	13	G1.X1 Power supply
22	AB1 Panel unit	13	G1.X2 Power supply
14,16,30	AB1.X1 Customer connection run chain	13	G1.X3 Power supply
14,16,30	AB1.X2 Customer connection run chain	13	G1.X5 Power supply
15,16,30	AB1.X3 External customer connection	13	G1.X7 Power supply
15,30	AB1.X4 External customer connection	19	G2 Battery
6,13,14,16,20,20.1,35	AB1.X5 Power unit/Power control	19	G3 Battery
14,15	AB1.X6 Control panel	71.1	I/O1-4 Profibus dp slave
14,15,22	AB1.X7 Teach pendant	41-47,70	I/O1-4 Remote I/O, Digital I/O, Relay output no 1-4
6,14,16	AB1.X8 Power unit/Power control	48	I/O1-4 Analogue I/O-Unit no 1-4
42,45,70,71.1	AB1.X9 CAN-bus I/O	42-49	I/O.XP5 Encoder I/O-Unit
19	AB1.X10 Back plane	49	I/O.XP20 Encoder I/O-Unit
40	AB2 Back plane bus	16	K1 Motor on contactor 1
19	AB2.X1 Data port SIO1	16	K2 Motor on contactor 2
19	AB2.X2 Data port SIO2	16	K3 Brake contactor
19	AB2.X3 Memory backup battery	3,33	KT1 Time relay for axes 1 IRB6400
19	AB2.X4 Memory backup battery	16	P1 Duty time counter
40	AB2.X10 CAN-bus external I/O	11	Q1 Mains switch
19	AB2.X11 Panel unit	16	Q2 Servo disconnecter
20.1	AB2.X12 Panel unit	3,40	R1.CB Can-Bus
40	AB2.X16 CAN-bus manipulator	32.1-32.2	R1.CP Manipulator connection, Customer Power
19	AB2.X17 Floppy disc signal	32-32.2	R1.CS Manipulator connection, Customer Signal
19	AB2.X18 Floppy disc power	31	R1.LS Manipulator connection, Position Switches
17,18,35	AB2.X22 Drive system	17-18,2,20.2-3	R1.MP Manipulator connection
20,20.1	AB2.X23 Measurement system	20,20.1	R1.SMB Manipulator connection, Serial Measurement Board
13	AB2.X24 Power supply	31	R1.SW Manipulator connection, Position Switches
19	B1 Temperature sensor, floppy disc cooling	17,18	R1.1-4 Bleeder resistor
19	D1 Floppy disc unit	17,18	R1.X1 Bleeder
		17,18	R1.X2 Bleeder
		16	R2, R3 Inrush current limiter resistors, DC-link
		20.1	R2.G Battery

Designation

Sheet

4

No. of sh.

54

SHEET	DESIGNATION	
3,12	T1	Transformer, Mains
3,12	T1.F1-2	Automatic fuse
3,12	T1.FU1-2	Fuse
3,12	T1.ST	Temperature sensor, transformer
3,12	T1.X1	Transformer connection
14-16	S1	Control panel
15	S1.1	Mode switch
14	S1.2	Motor on, PB
14	S1.3	Emergency stop PB
3,11	XP0	Mains Plug
32-34	XP,XS,XT5	Customer signal connection
32.1,32.2	XP,XS,XT6	Customer power connection
31	XP8.1	Position switch
31	XP8.2	Position switch
17,18	XP15	Fans E1-E4
17,18	XP16	Fans E1-E4
17.1,18.1,20,20.1	XP18	PTC, Brake, Limit extension
23	XP/XS19	External control panel
17.1,18.1	XP23	Internal control cable
19	XP24	Fan E5
19	XP25	Fan E5
3,40	XP,XS29	Con-Bus
11	XP30	Mains switch connection
35	XP33	External axis, control signal extension
3,6,13,17-18.2,20-20.2	XS1	Outlet control cable power
3,6,20,20.1	XS2	Outlet control cable signal
3,6,30	XS3	Customer connection
3	XS5	Customer signal, connection
3,23	XS6	Customer power, connection
3,6,35	XS7	External axis, connection
3,6,31	XS8	Position switch
3,41	XS11-14	I/O Unit 1-4

SHEET	DESIGNATION	
17,18	XS15	Fans E1-E4
17,18	XS16	Fans E1-E4
3,40	XS17	Con-Bus
20,20.1	XS/X18	PTC, Brake, Limit extension
3,14,15,22	XS20	Teach Pendant outlet
21	XS21	Service outlet connection
21	XS22	Service outlet connection
21	XS23	Service 230V outlet
19	XS24	Fan E5
19	XS25	Fan E5
20.1	XS27	External axes measurement board
11	XS30	Mains switch connection
35	XS,X33	External axis, control signal extension
3	XS35	External axes cubicle connection
31	XT8.1	Position switch
31	XT8.2	Position switch
21	XT21	Service outlet connection
21	XT22	Service outlet connection
11	XT26	Direct supply connection
13	XT31	Customer I/O supply
13	XT32	Brake extension
11	Z1	Mains filter
11	Z1.XP30	Mains filter connection
12	Z1.XS30	Mains filter connection

Designation

Sheet	5
No. of sh.	54

KEYING POS.	
XS8	Y

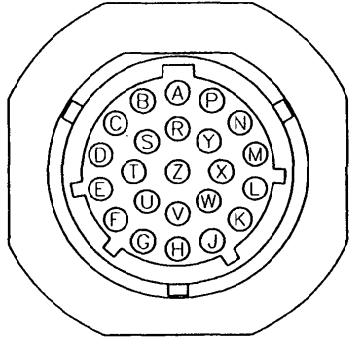

KEYING POS.	
XS2	M

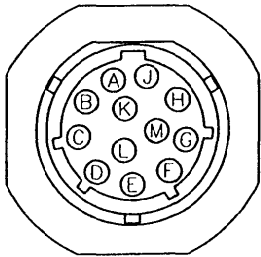

KEYING POS.	
XP6	Y

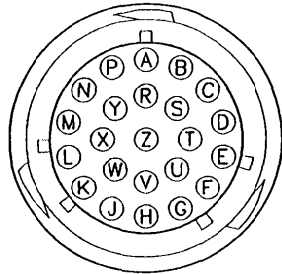

KEYING POS.	
A81.XS5	A
A81.XS8	B

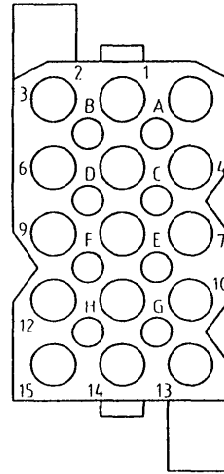

Contact	KEYING POS.			
	A	B	C	D
XS1/XS6/ XP/XS35			⊗	⊗
XS3/XS5	⊗	⊗		
XS7	⊗		⊗	
XP/XS11	⊗			⊗
XP/XS12		⊗		
XP/XS13				⊗
XP/XS14			⊗	
XS19		⊗		⊗
XS27	⊗			

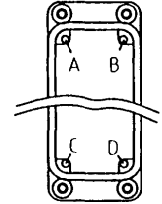

Contact	KEYING POS.			
	A	B	C	D
R1CP/CS	⊗	⊗		

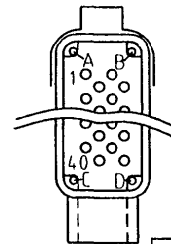

Sheet 6
No. of sh. 54

Keying

Contact no.1

Phoenix, Type: "MDSTBV 2.5/-G-5.08"

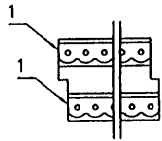

Contact no.2

Phoenix, Type: "MSTBVA 2.5/-G-5.08"

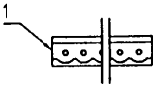

Contact no.3

Part no. 3HAB 7391

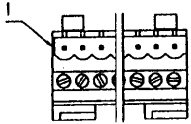

Contact no.4

Part no. 2664 165

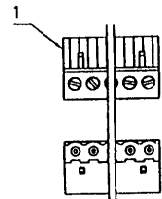

KEYING POS. / NYCKLINGS POS.		Contact no./ Kontakt nr	Item/ Benämning	Comments/ Övrigt
Alt.	1 2 3 4 5 6			
1	X X X X X	4	I/O Combi, X6	
2	X X X X X	2	I/O Combi, X6	
3	X X X X X	5	Power sup, X522	
4	X X X X X	3	Power sup, XT22	
5	X X X X X		FREE	
6	X X X X X		FREE	
7	X X X X X	4	Panelboard, X9	
8	X X X X X	2	Panelboard, X9	
9	X X X X X	4	Backplane, X10	
10	X X X X X	1	Backplane, X10	3 Modules
11	X X X X X	4	Backplane, X16	
12	X X X X X	1	Backplane, X16	3 Modules
1 2 3 4 5 6 7 8 9 10				
20	X X X X	4	Dig. I/O, X1	
21	X X X X	1	Dig. I/O, X1	
22	X X X X	4	Dig. I/O, X3	
23	X X X X	1	Dig. I/O, X3	2 Modules
24	X X X X	4	Dig. I/O, X2	
25	X X X X	1	Dig. I/O, X2	
26	X X X X	4	Dig. I/O, X4	
27	X X X X	1	Dig. I/O, X4	2 Modules
1 2 3 4 5 6 7 8 9 10 11 12				
40	X X X X X	6	Pos. switch, XT8.1	
41	X X X X X	3	Pos. switch, XP8.1	
42	X X X X X	6	Pos. switch, XT8.2	
43	X X X X X	3	Pos. switch, XP8.2	
44	X X X X X	6	Cust. cable, XP5.1	
45	X X X X X	3	Cust. cable, XP5.1	
46	X X X X X	6	Cust. cable, XT5.2	
47	X X X X X	3	Cust. cable, XP5.2	

Contact no.5

Part no. 3HAB 7404

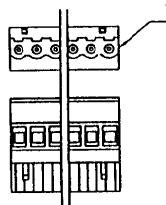

Contact no.6

Part no. 3HAB 7100

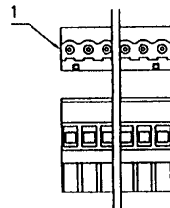

KEYING POS. / NYCKLINGS POS.		Contact no./ Kontakt nr	Item/ Benämning	Comments/ Övrigt
Alt.	1 2 3 4 5 6 7 8 9 10 11 12 13 14 15 16			
48	X X X X X	6	Customer power, XT6	
49	X X X X X	3	Customer power, XP6	
50	X X X X X	4	Backplane, X1	
51	X X X X X	1	Backplane, X1	
52	X X X X X	4	Backplane, X2	
53	X X X X X	1	Backplane, X2	3 Modules
54	X X X X X	4	Panelboard, X1	
55	X X X X X	1	Panelboard, X1	
56	X X X X X	4	Panelboard, X2	
57	X X X X X	1	Panelboard, X2	3 Modules
58	X X X X X	4	Panelboard, X4	
59	X X X X X	1	Panelboard, X4	3 Modules
60	X X X X X	4	Panelboard, X3	
61	X X X X X	1	Panelboard, X3	
62	X X X X X	4	Can bus I/O, X5	
63	X X X X X	2	Can bus I/O, X5	
64	X X X X X		Free	
65	X X X X X		Free	
66	X X X X X		Free	
67	X X X X X		Free	
1 2 3 4 5 6 7 8 9 10 11 12 13 14 15 16				
90	X X X X X	4	120VAC, Dig with relays, X3	
91	X X X X X	1	120VAC, Dig with relays, X3	2 Modules
92	X X X X X	4	120VAC, Dig with relays, X1	
93	X X X X X	1	120VAC, Dig with relays, X1	
94	X X X X X	4	120VAC, Dig with relays, X2	
95	X X X X X	1	120VAC, Dig with relays, X2	
96	X X X X X	4	120VAC, Dig with relays, X4	
97	X X X X X	1	120VAC, Dig with relays, X4	2 Modules
98	X X X X X		Encoder unit	Contact
99	X X X X X		Encoder unit	Board
100	X X X X X		Free	
101	X X X X X		Free	
102	X X X X X		Free	
103	X X X X X		Free	

Keying

Contact no: /
 Kontakt nr: 1
 Art. No: 3HAC 1460

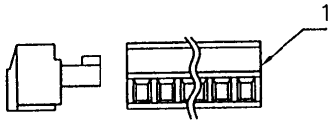

Contact no: /
 Kontakt nr: 2
 Art. no: "Phoenix," Type:
 MCD 1.5/...-G-3.81"

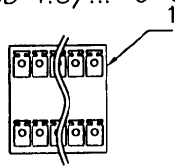

KEYING POS. / NYCKLINGS POS.																Contact no/ Kontakt nr	Item/ Benämning	Comments/ Övrigt	
Alt.	1	2	3	4	5	6	7	8	9	10	11	12	13	14	15				16
40		X		X	X												1 and 2	Analogt I/O X7 1-12	
42				X	X												1 and 2	Analogt I/O X7 13-24	
KEYING POS. / NYCKLINGS POS.																			
	1	2	3	4	5	6	7	8	9	10	11	12	13	14	15	16			
60		X		X													1 and 2	120VAC, Dig with relays, X3	
62			X	X													1 and 2	120VAC, Dig with relays, X3	2 Modules

Keying

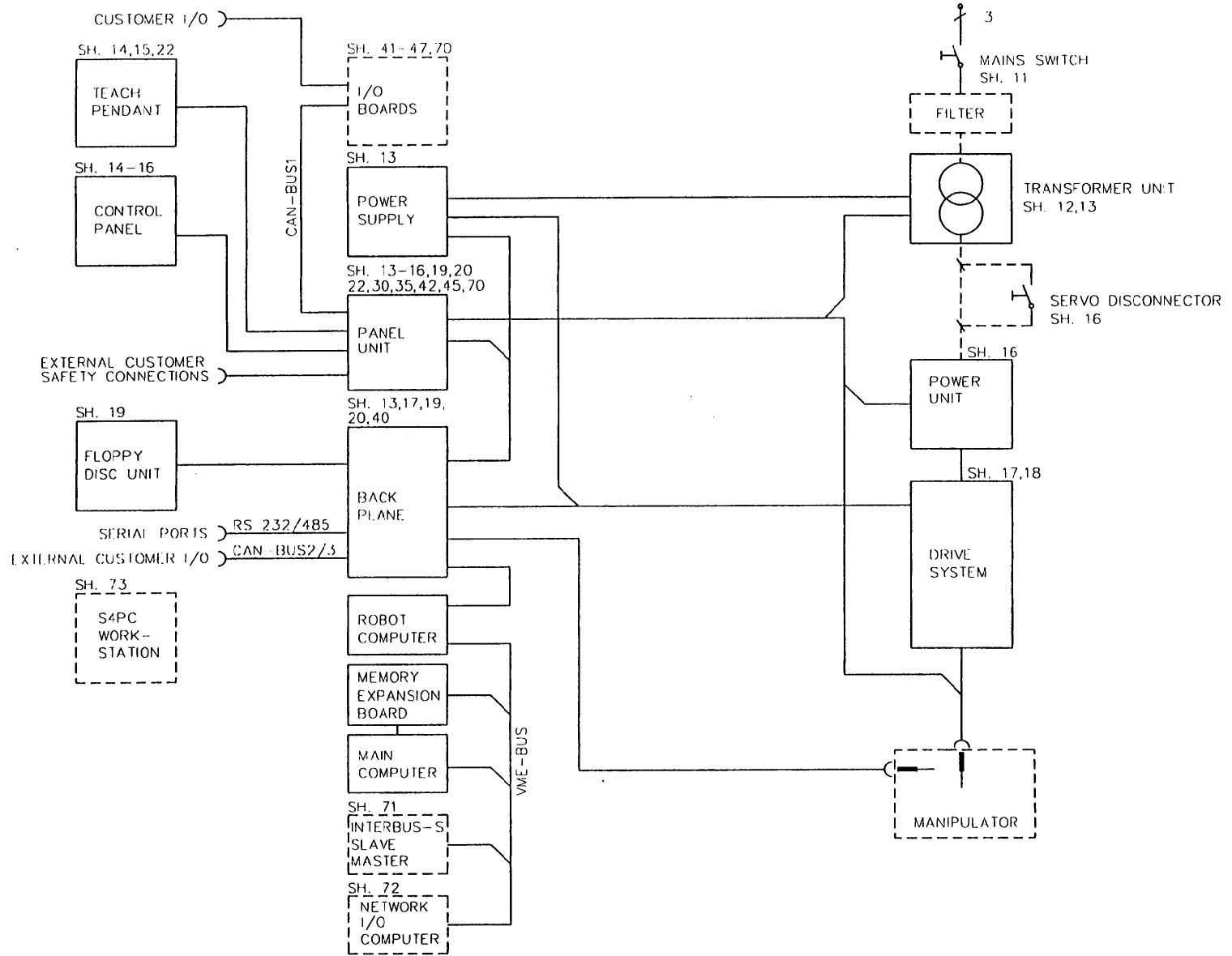

Block diagram

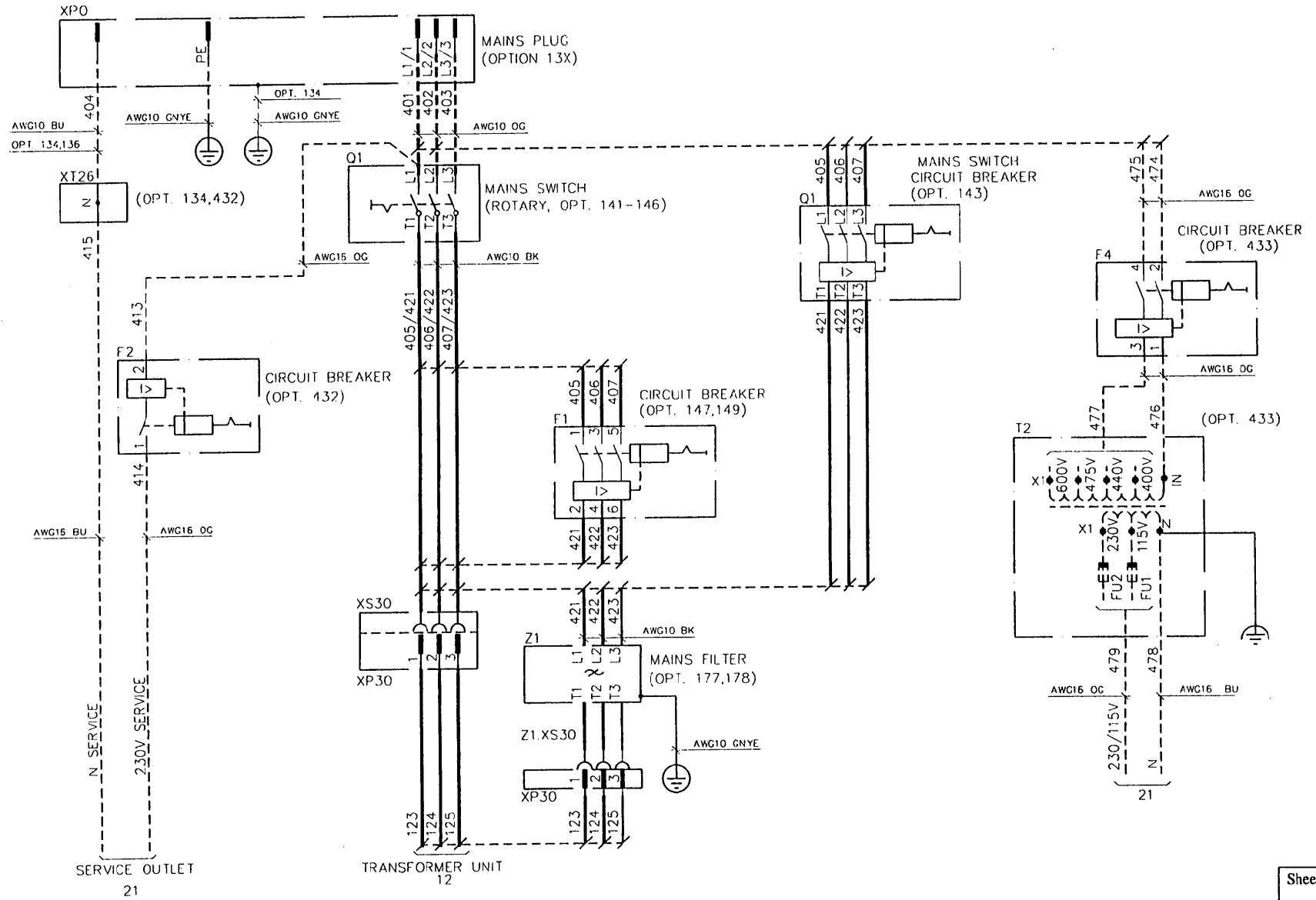

Mains connection

TRANSF. TYPE 2)	ROBOT TYPE	T1 MAINS VOLTAGE			JUMPERS T1.X1
		3HAC 0747-1	3HAC 0749-1	3HAC 0750-1	
1	1400/H,2400L/10/16	3HAC 0751-1	3HAC 0752-1	3HAC 0753-1	INI-E,IN2-E,IN3-E
2	1400/H,2400L/10/16,4400,6400	3HAC 0754-1	3HAC 0755-1	3HAC 0756-1	INI-F,IN2-F,IN3-F
3	6400C,PE ,640,840				INI-G,IN2-G,IN3-G
		200V	400V	475V	INI-H,IN2-H,IN3-H
		220V	440V	500V	
		400V	475V	525V	
		440V	500V	600V	

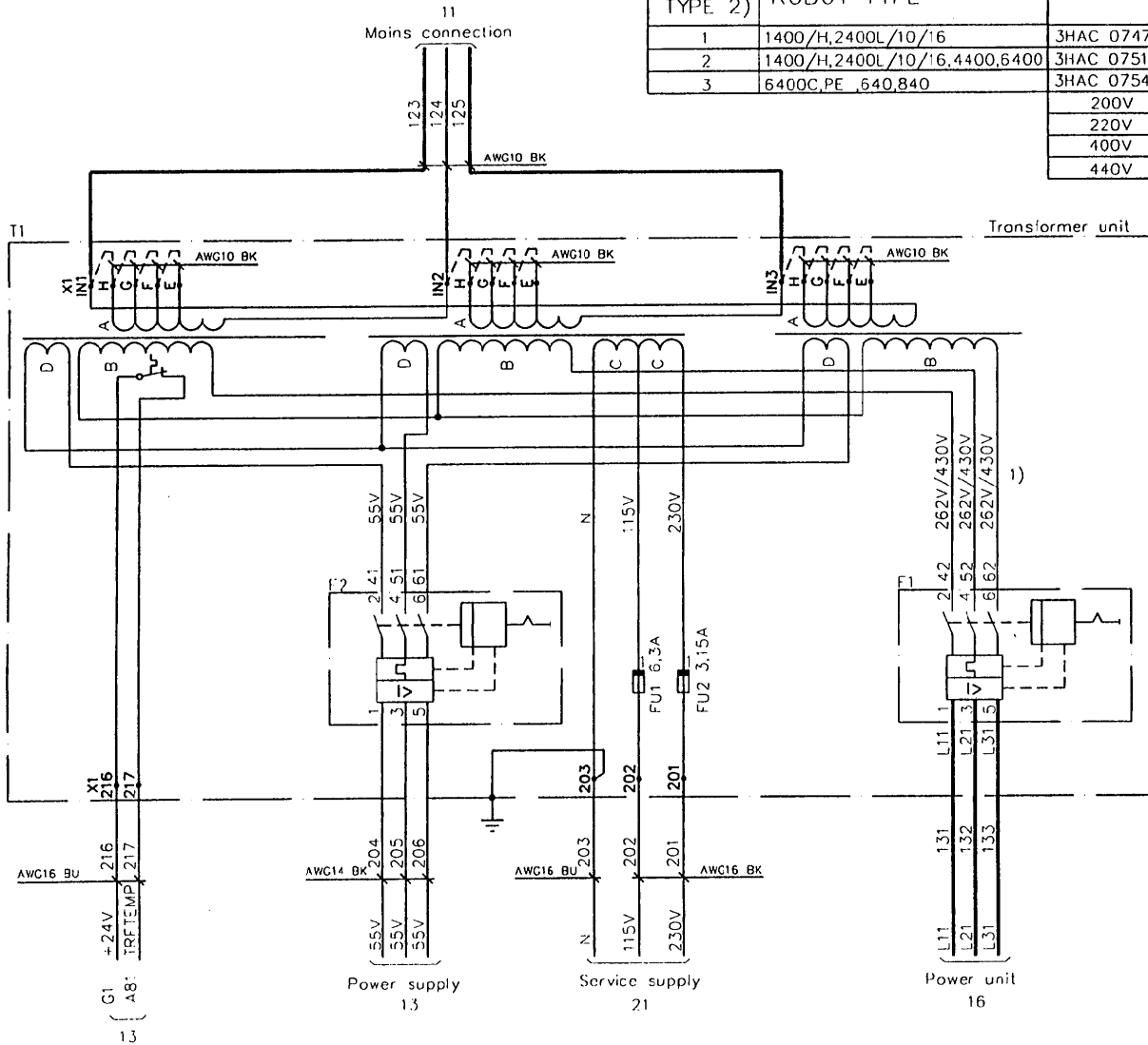

2) Transformer type 2 in 1400/2400 if external axes

1) IRB 6400C,PE = 430V
Others = 262V

Transformer unit

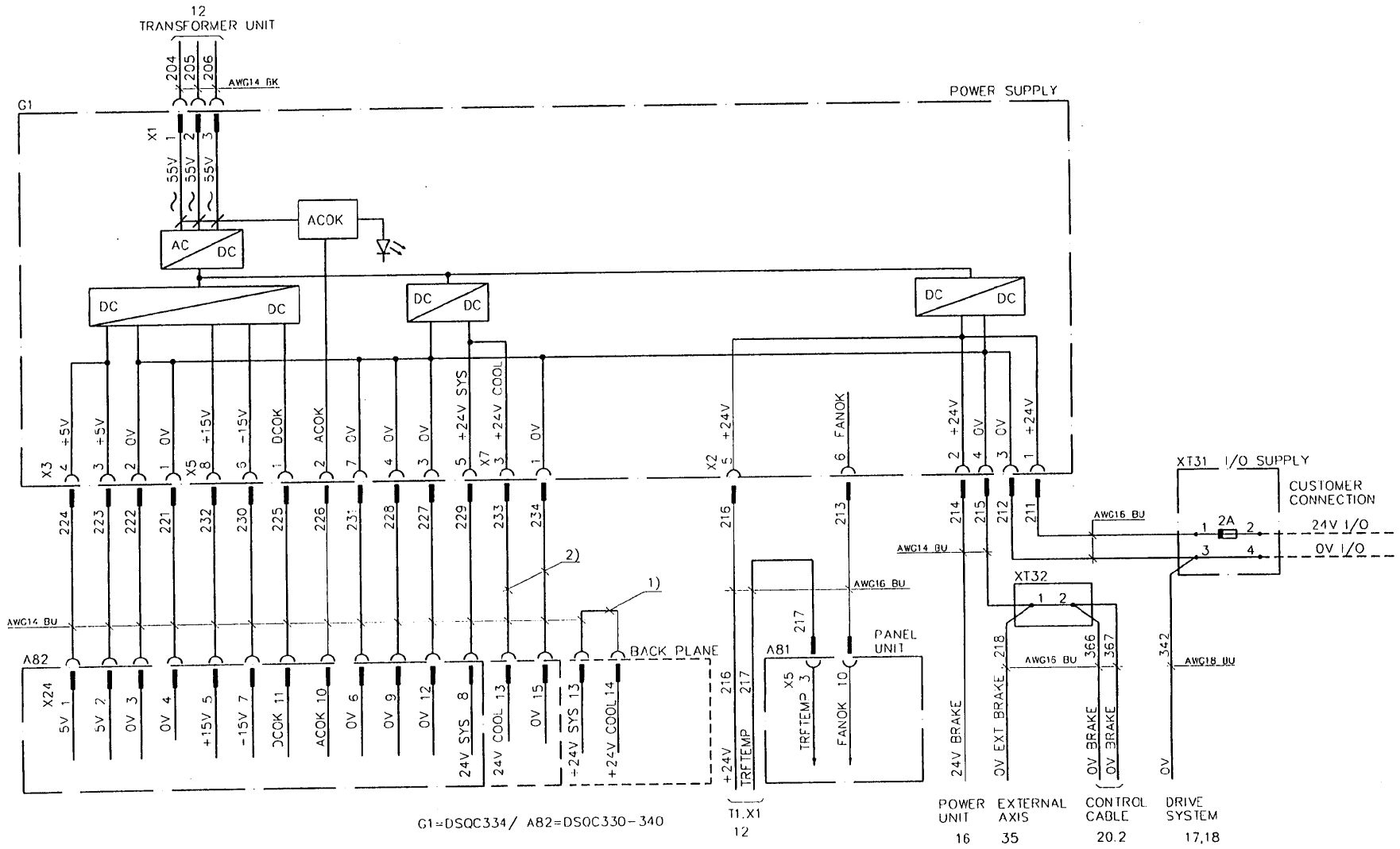

G1=DSQC334 / A82=DSQC330-340

1) G1=DSQC374 / A82=DSQC369-370

2) G1=DSQC365 / A82=DSQC369-370

Power supply, I/O supply

Sheet	13
No. of sh.	54

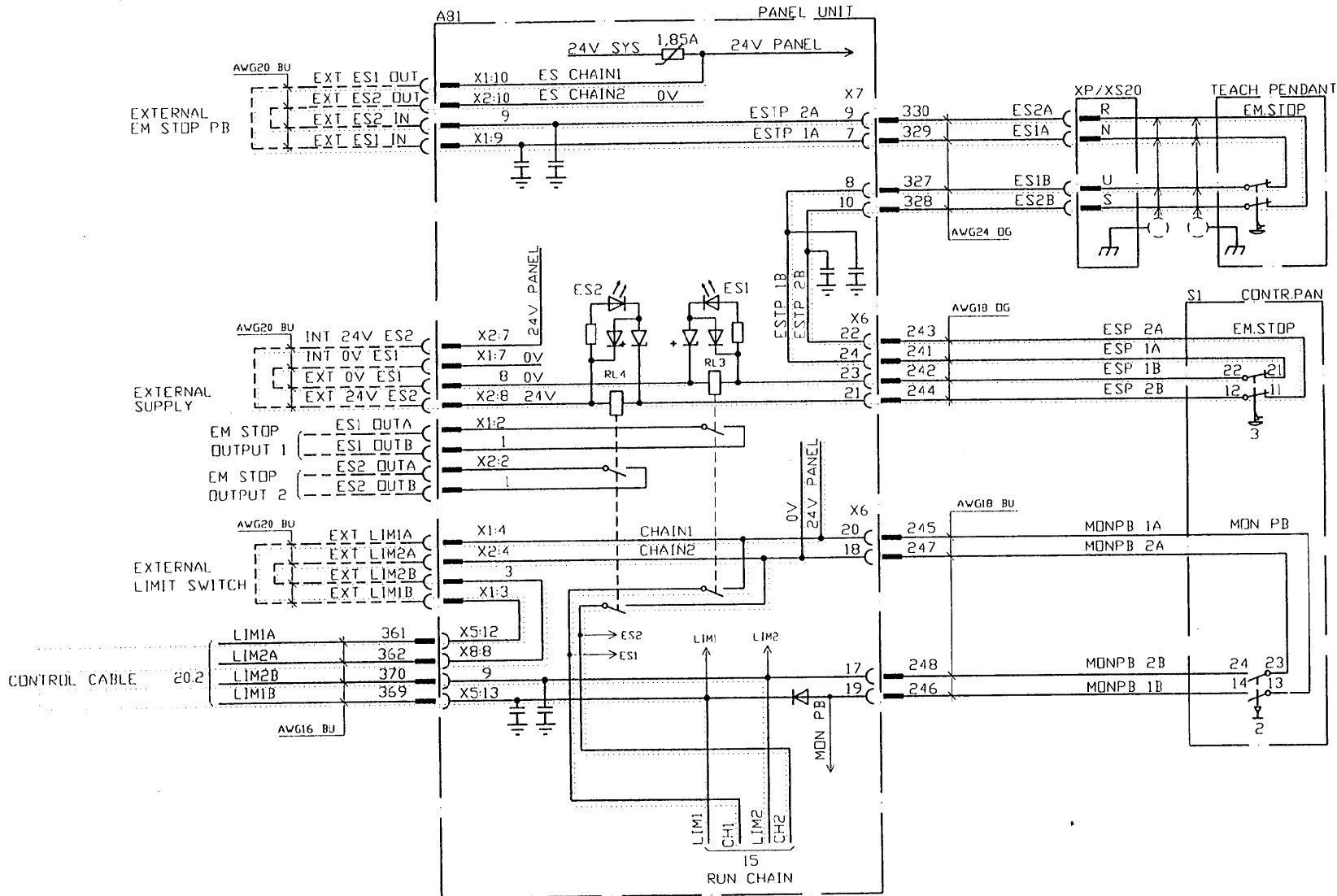

Emergency stop

Sheet	14
No. of sh.	54

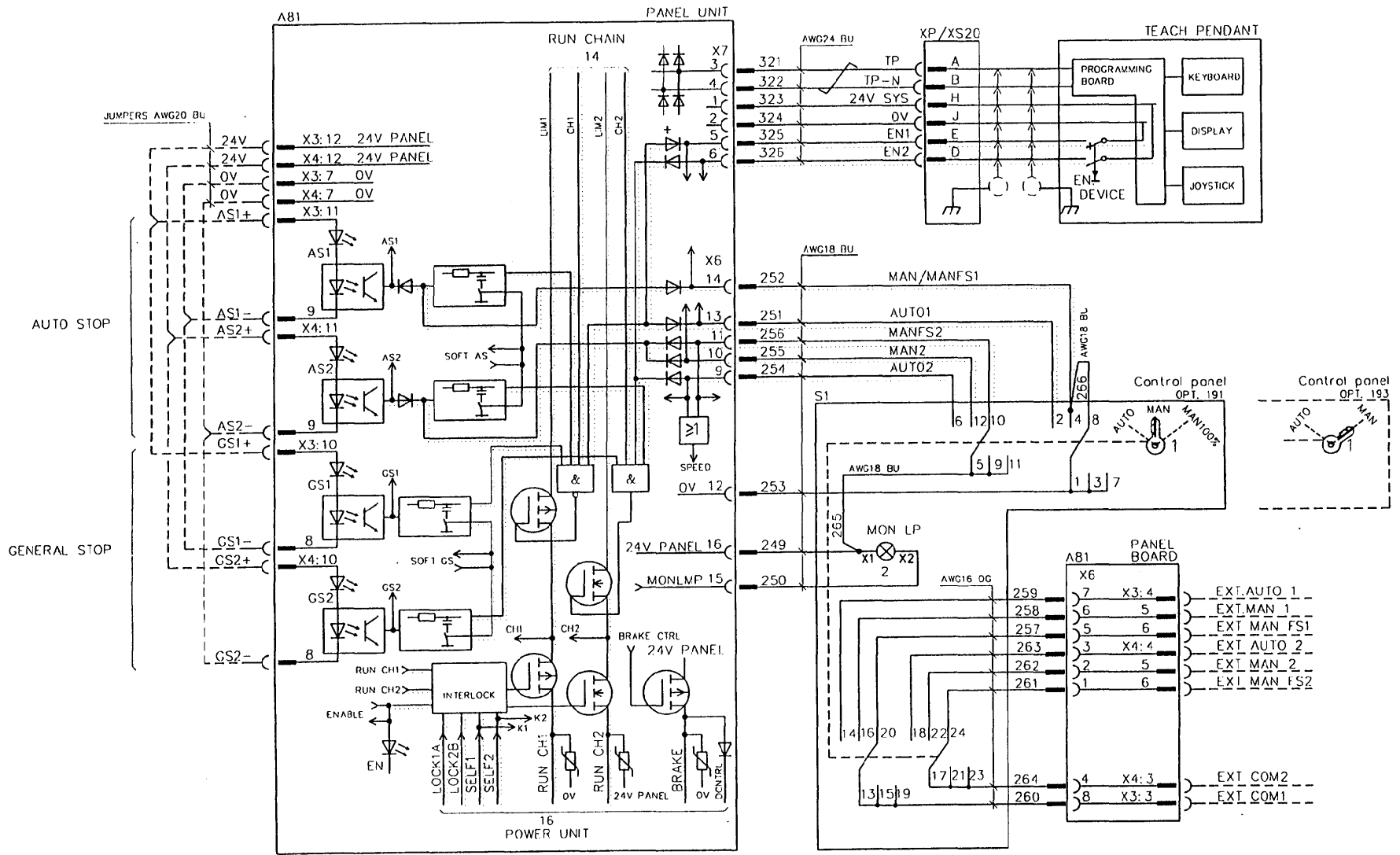

Run chain

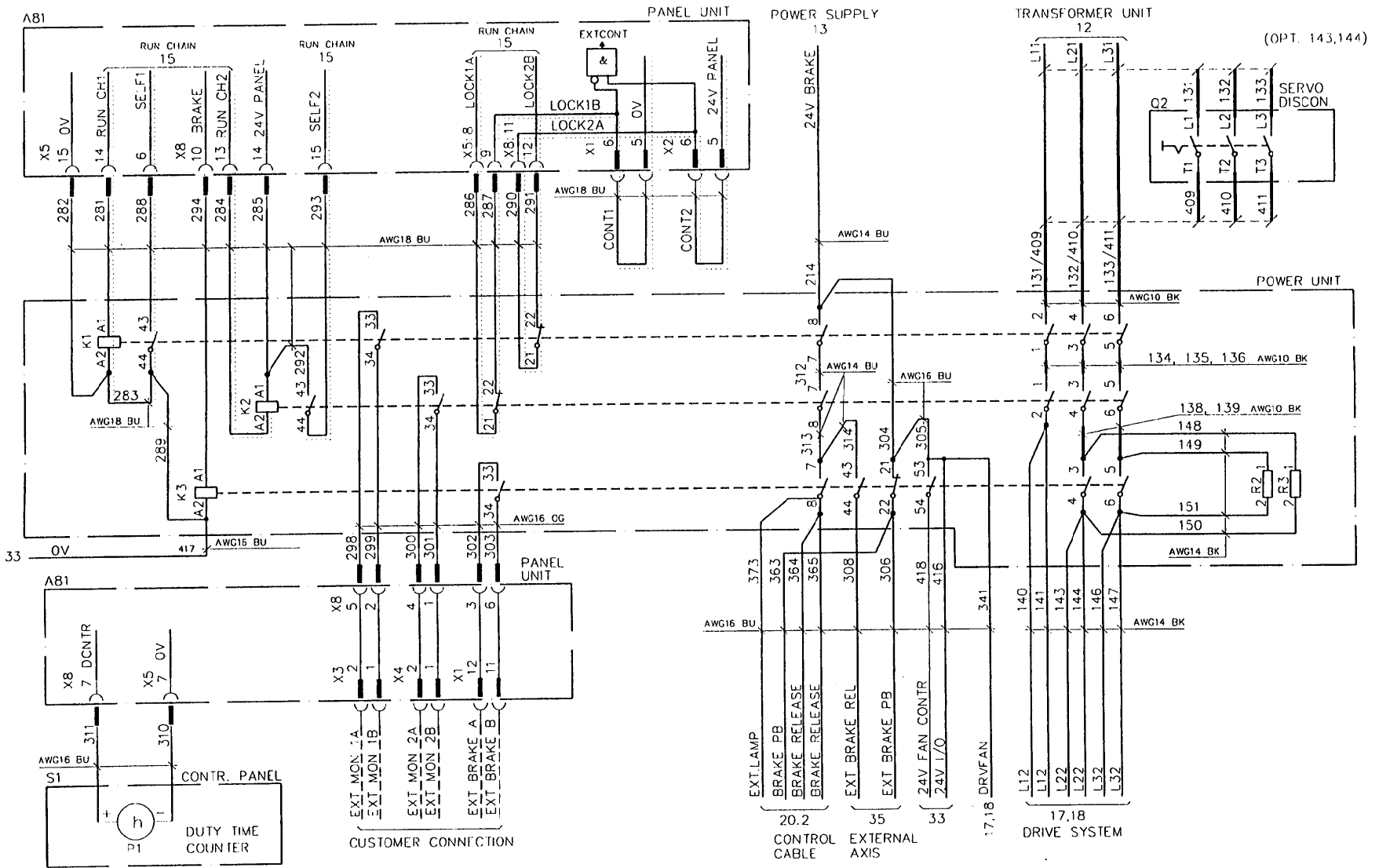

Power unit, servo disconnector

Sheet	16
No. of sh.	54

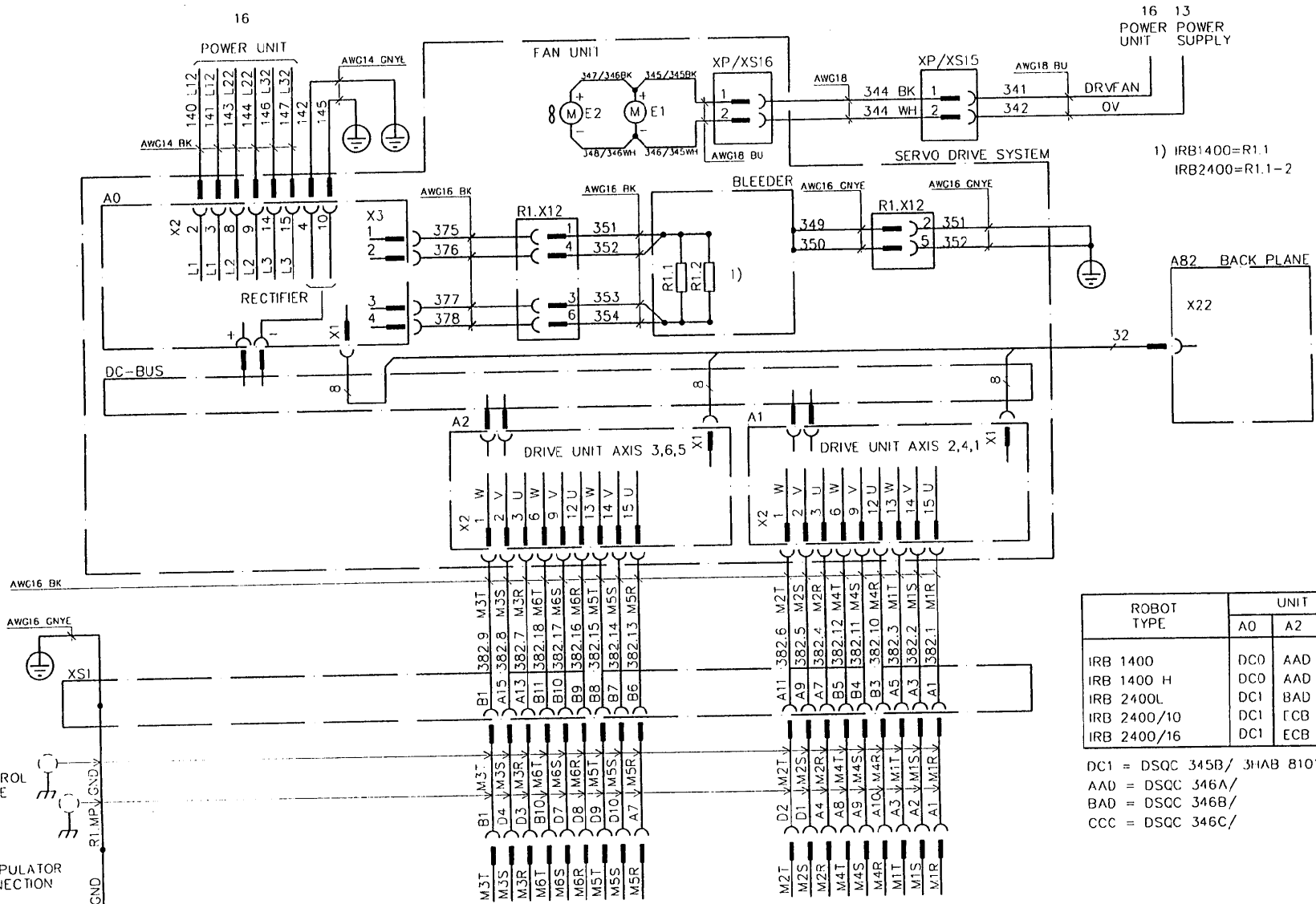

1) IRB1400=R1.1
IRB2400=R1.1-2

ROBOT TYPE	UNIT		
	A0	A2	A1
IRB 1400	DC0	AAD	AAD
IRB 1400 H	DC0	AAD	BAD
IRB 2400L	DC1	BAD	CCC
IRB 2400/10	DC1	ECB	CCB
IRB 2400/16	DC1	ECB	BAD

DC1 = DSQC 345B/ 3HAB 8101-2
 AAD = DSQC 346A/ -5
 BAD = DSQC 346B/ -6
 CCC = DSQC 346C/ -7

Servo drive system, ext. conn. IRB 1400, 1400H, 2400L, /10, /16

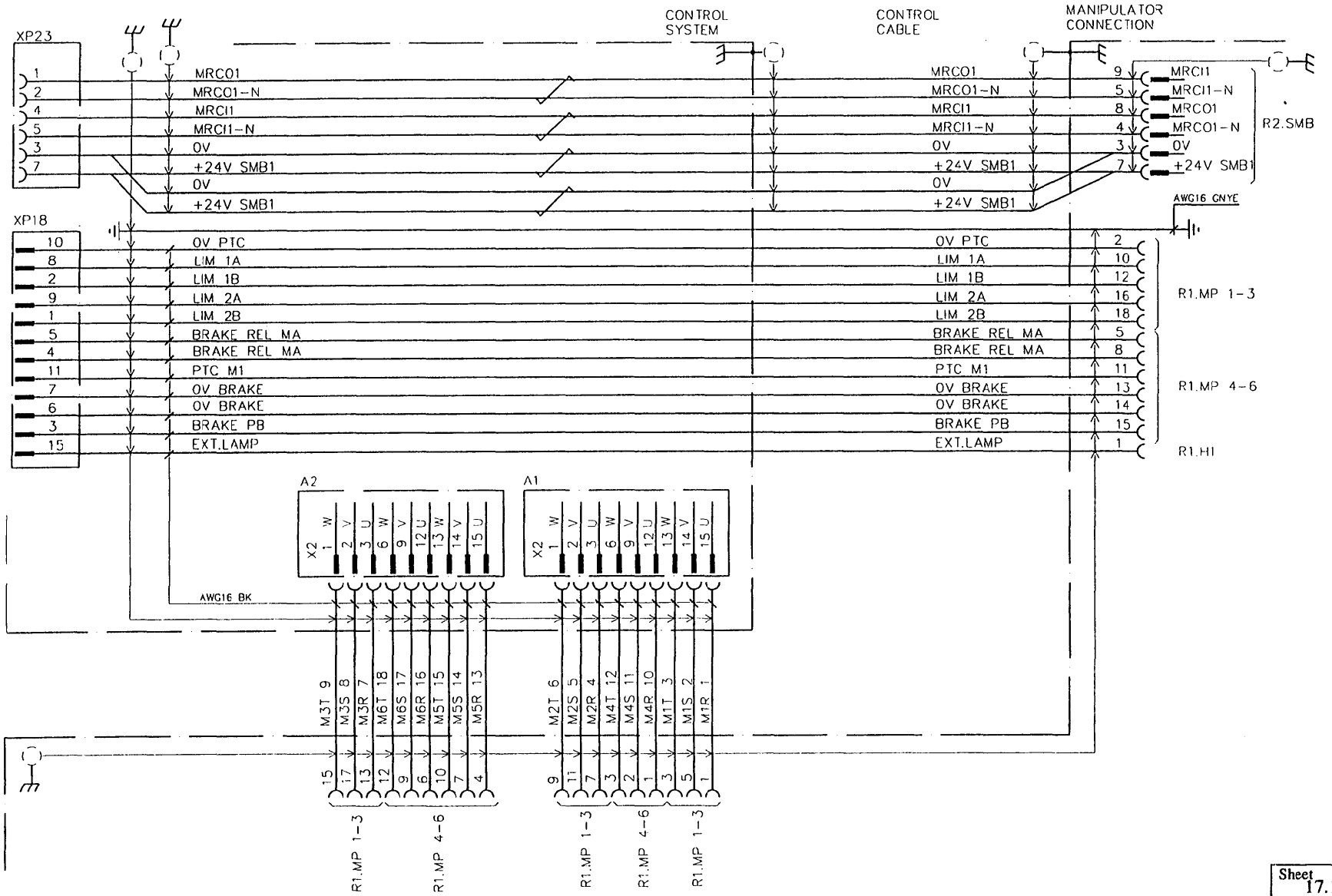

Internal control cable IRB 1400, 1400H, 2400L, /10, /16

Sheet
17.1

No. of sh.
54

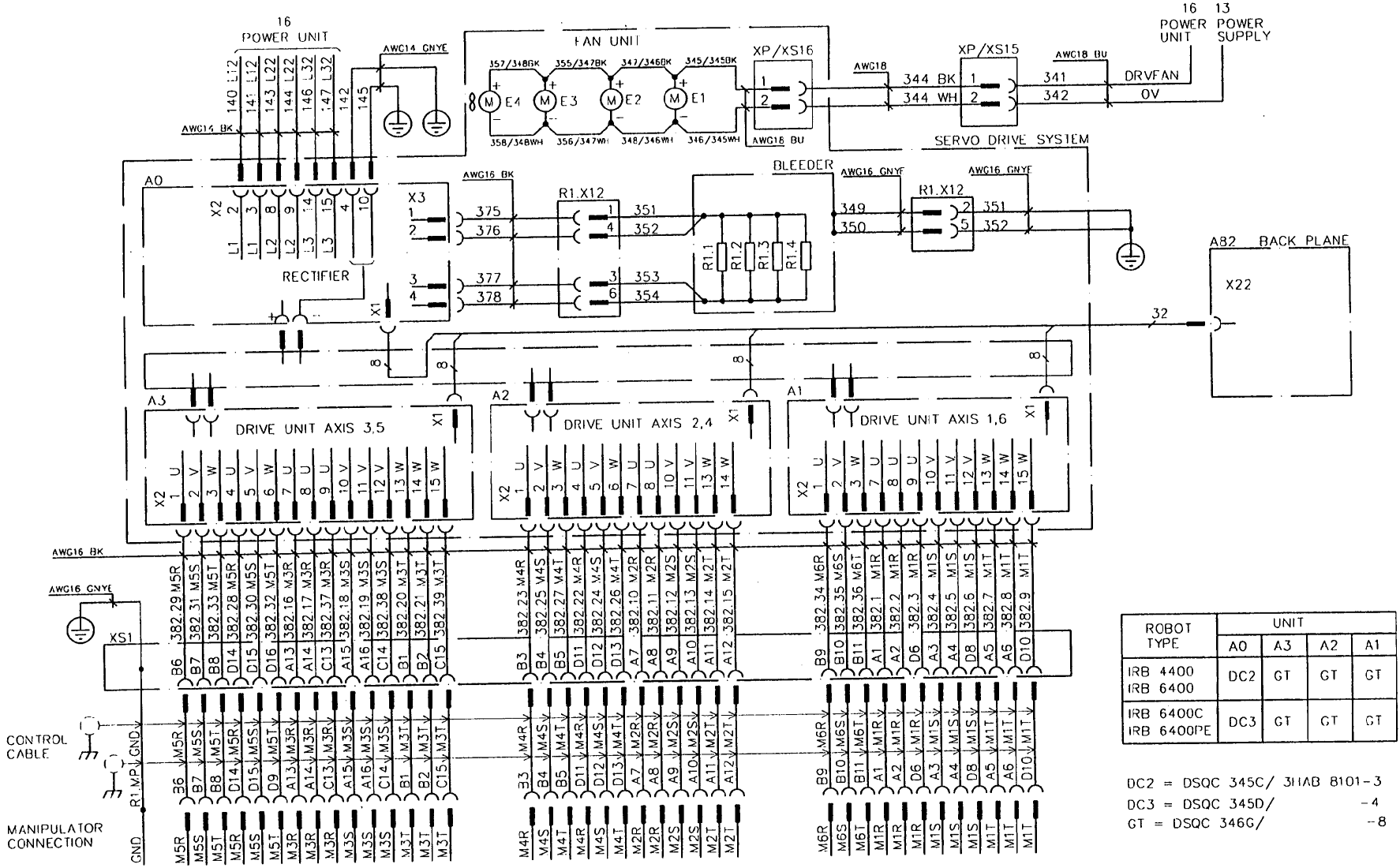

ROBOT TYPE	UNIT			
	A0	A3	A2	A1
IRB 4400	DC2	GT	GT	GT
IRB 6400	DC2	GT	GT	GT
IRB 6400C	DC3	GT	GT	GT
IRB 6400PE	DC3	GT	GT	GT

DC2 = DSQC 345C/ 3I1AB 8101-3
 DC3 = DSQC 345D/ -4
 GT = DSQC 346C/ -8

Servo drive system, ext. conn. IRB 4400, 6400

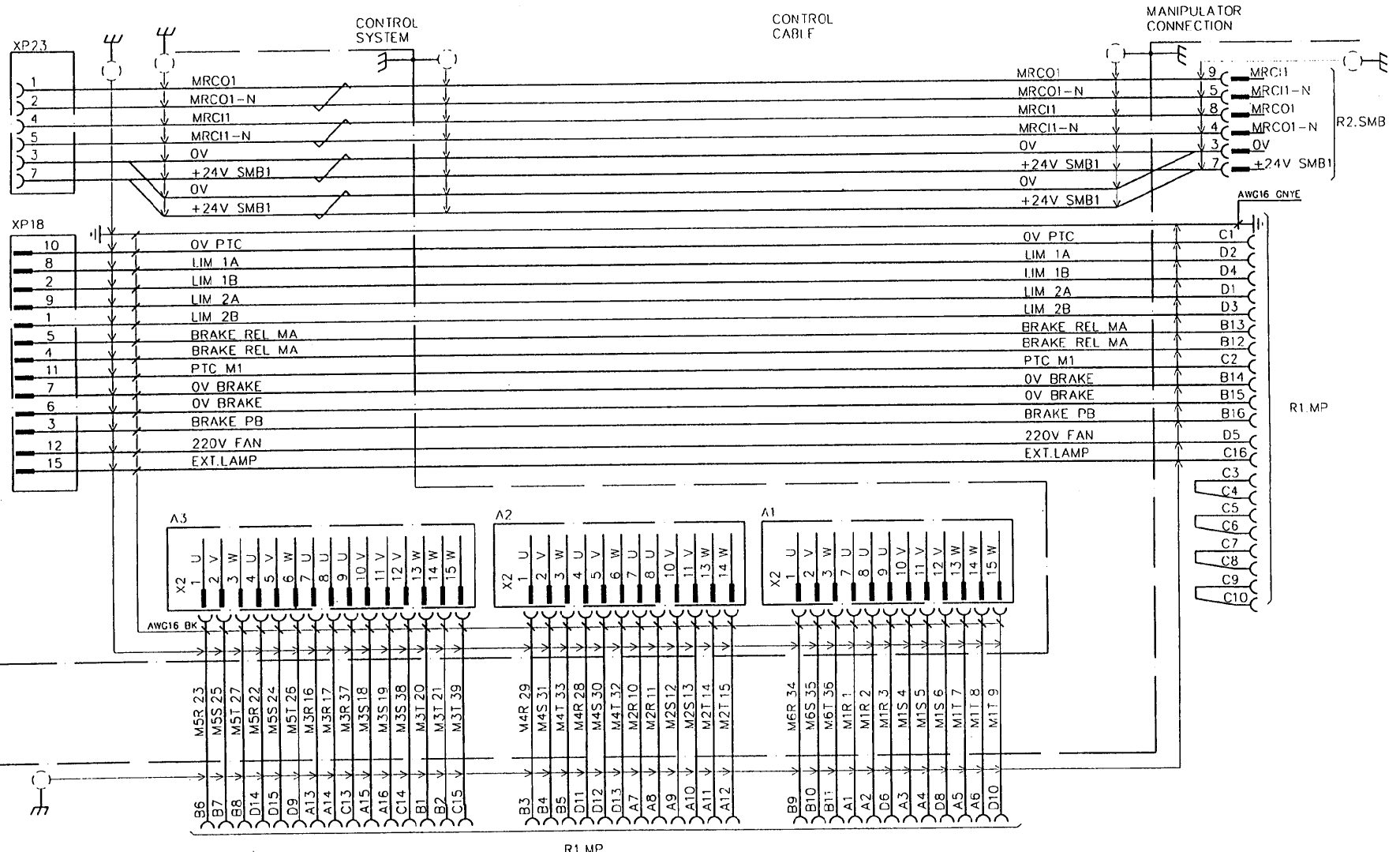

Internal control cable IRB 4400, 6400

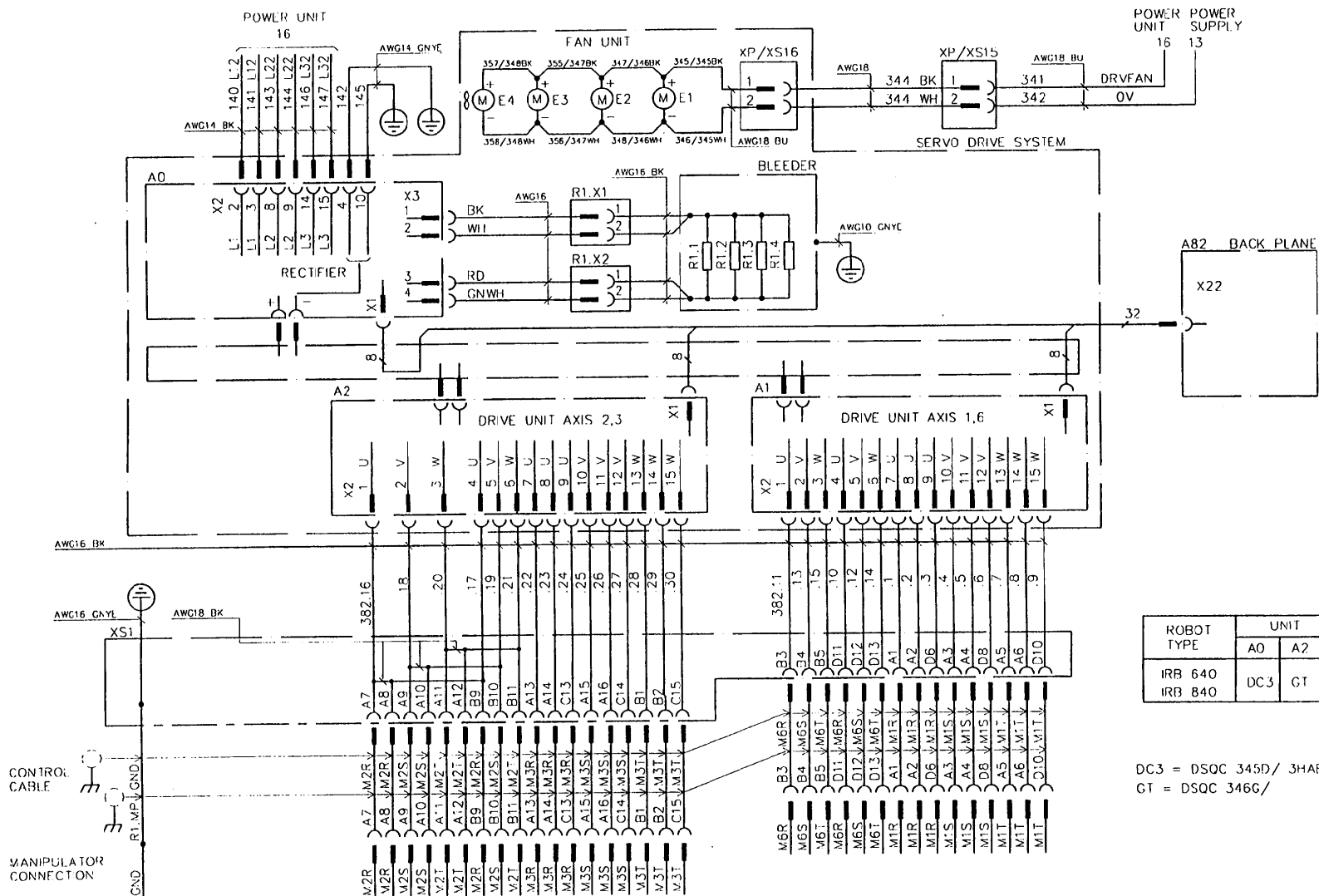

ROBOT TYPE	UNIT		
	A0	A2	A1
IRB 640	DC3	GT	CT
IRB 840			

DC3 = DSOC 345D/ 3HAB 8101-4
 GT = DSOC 346G/ -8

Servo drive system IRB 640 and IRB 840

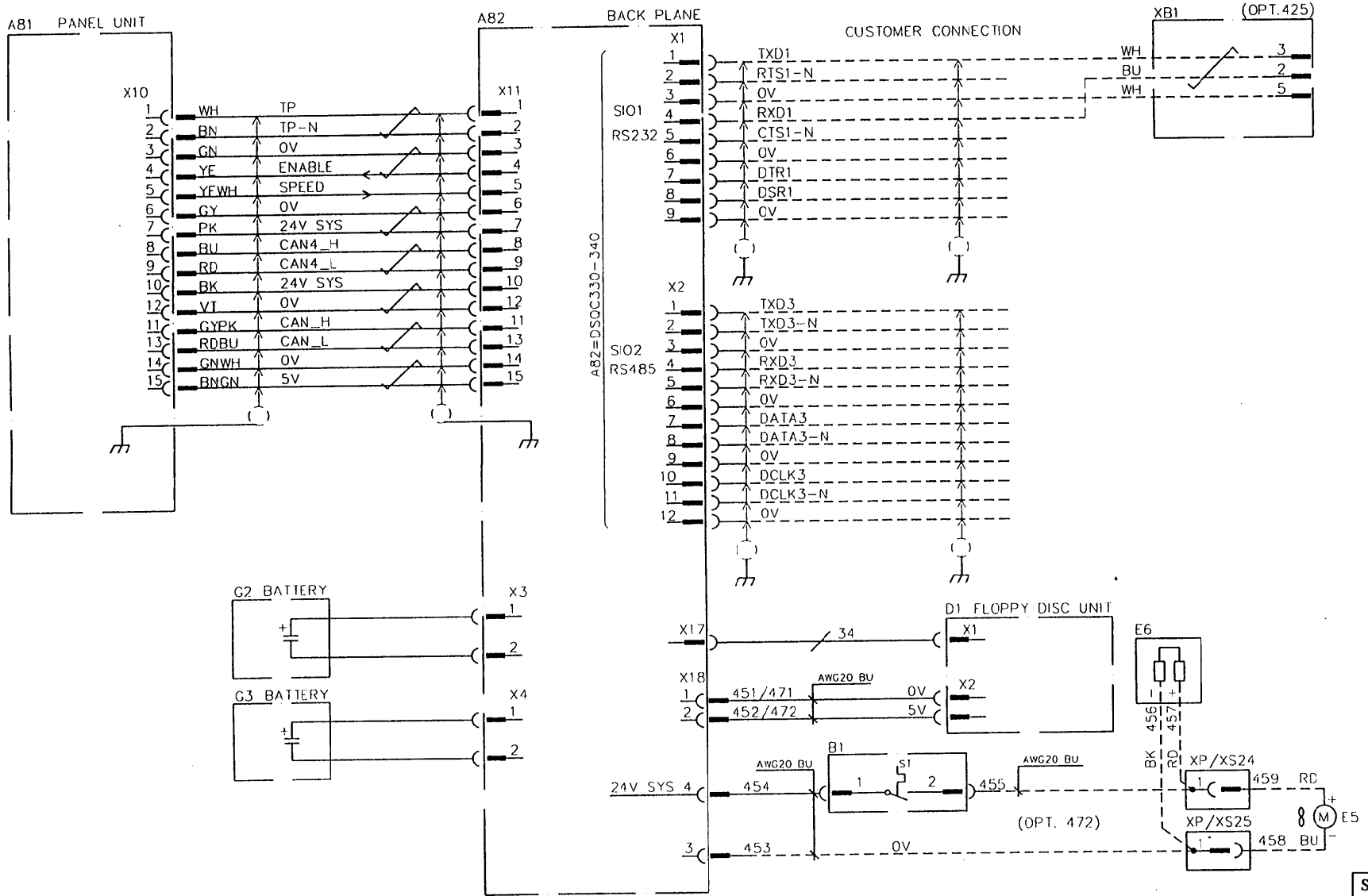

Floppy disk unit, serial ports and batteries

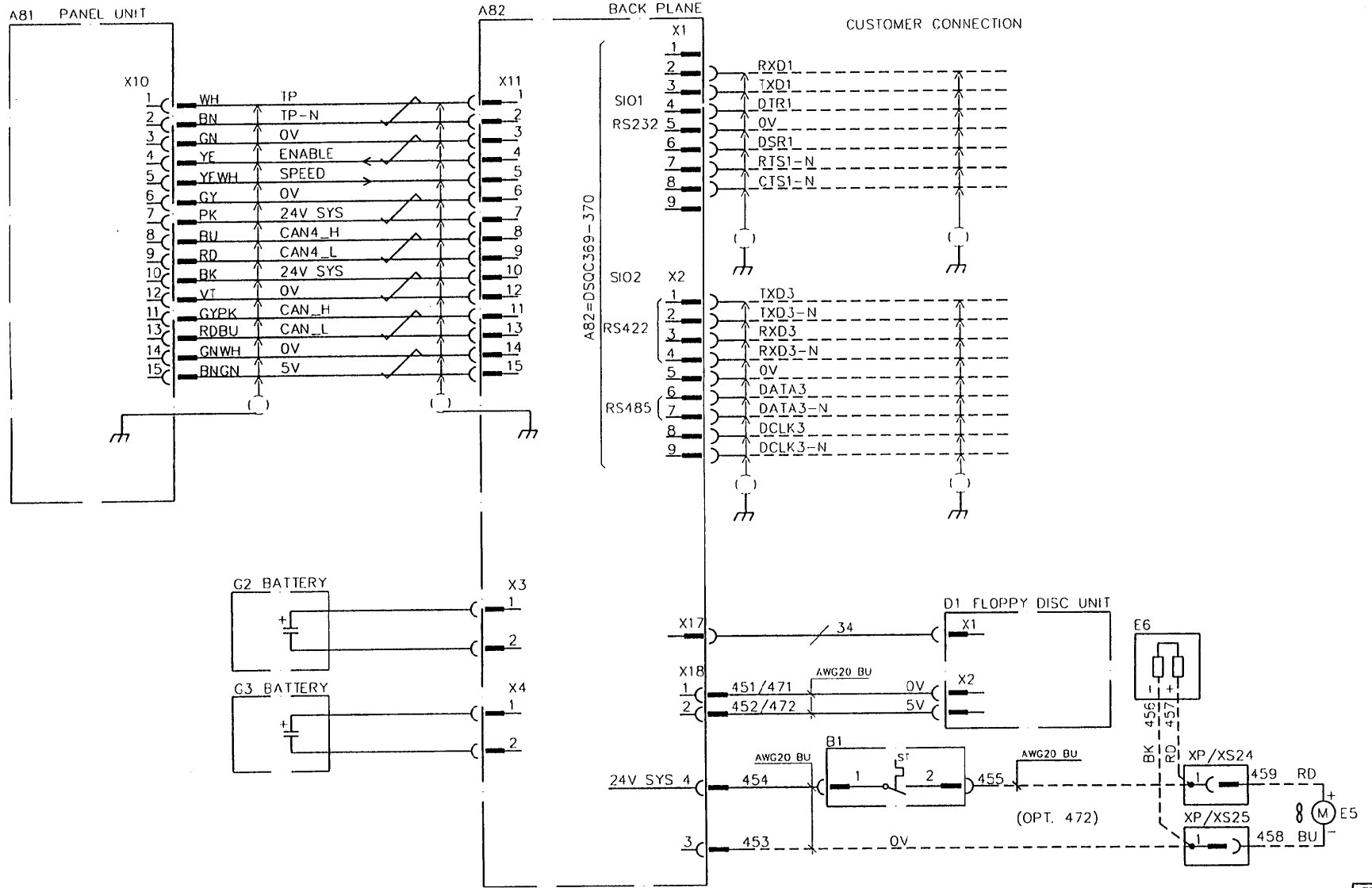

Floppy disk unit, serial ports and batteries

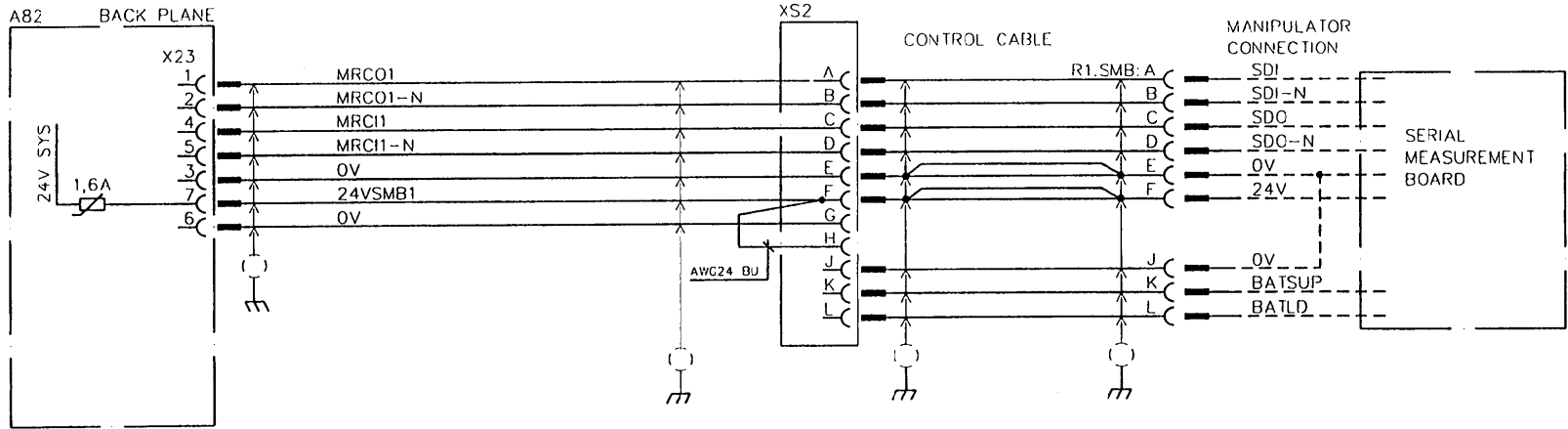

External measurement board

Sheet	20
No. of sh.	54

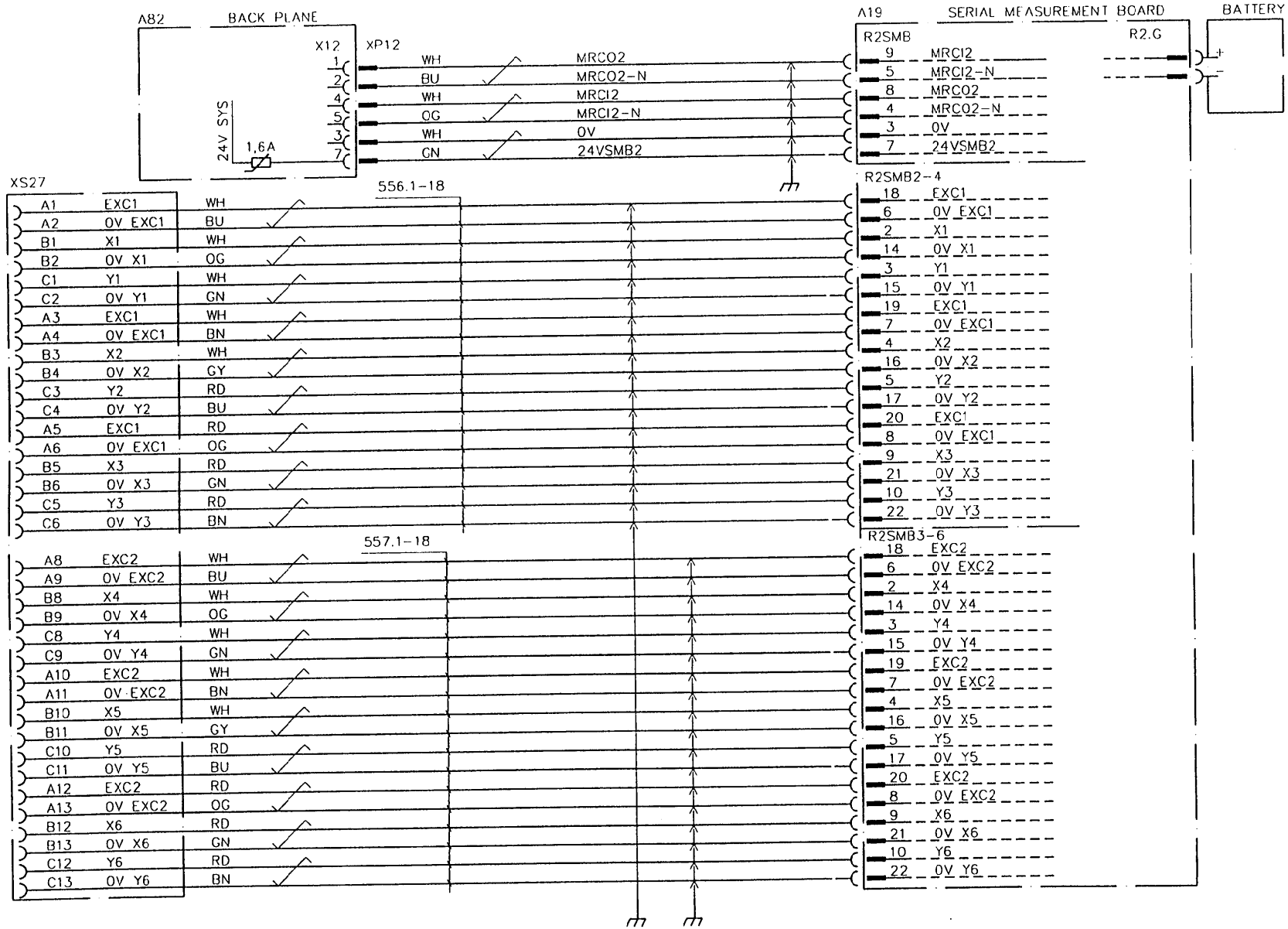

External axes measurement board

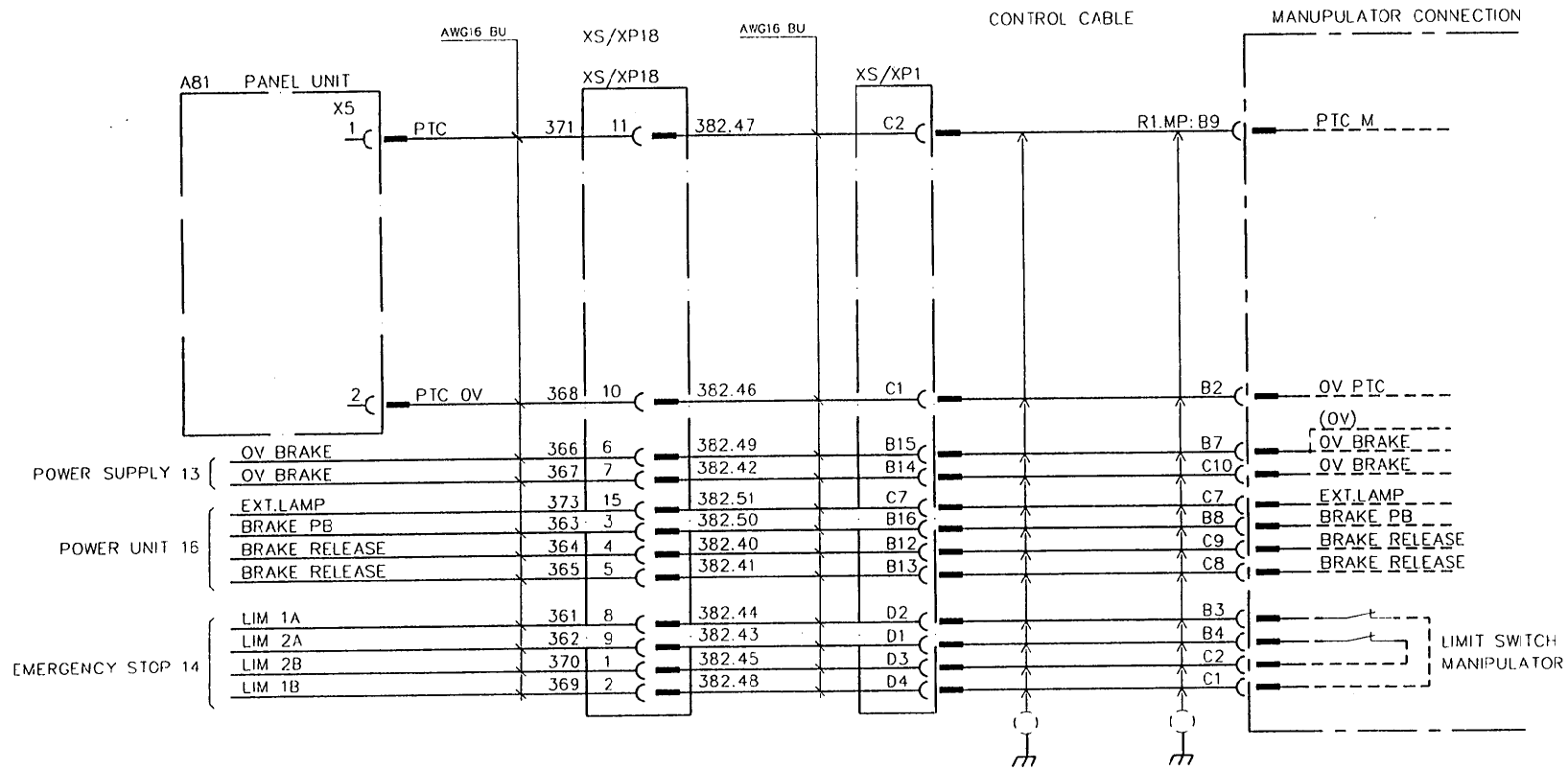

Control cables IRB 1400-2400

Sheet	20.2
No. of sh.	54

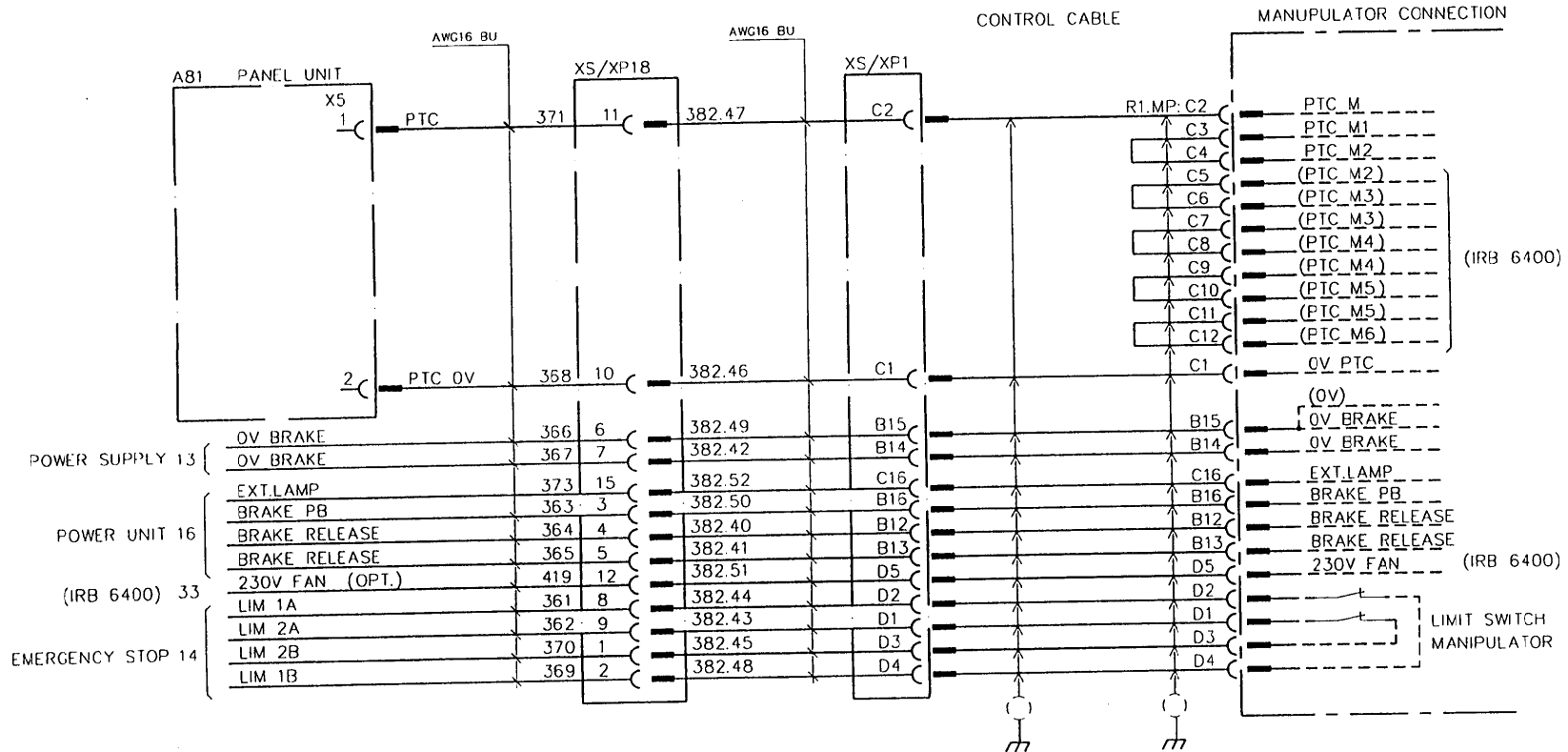

Control cables IRB 4400-6400

Sheet	20.3
No. of sh.	54

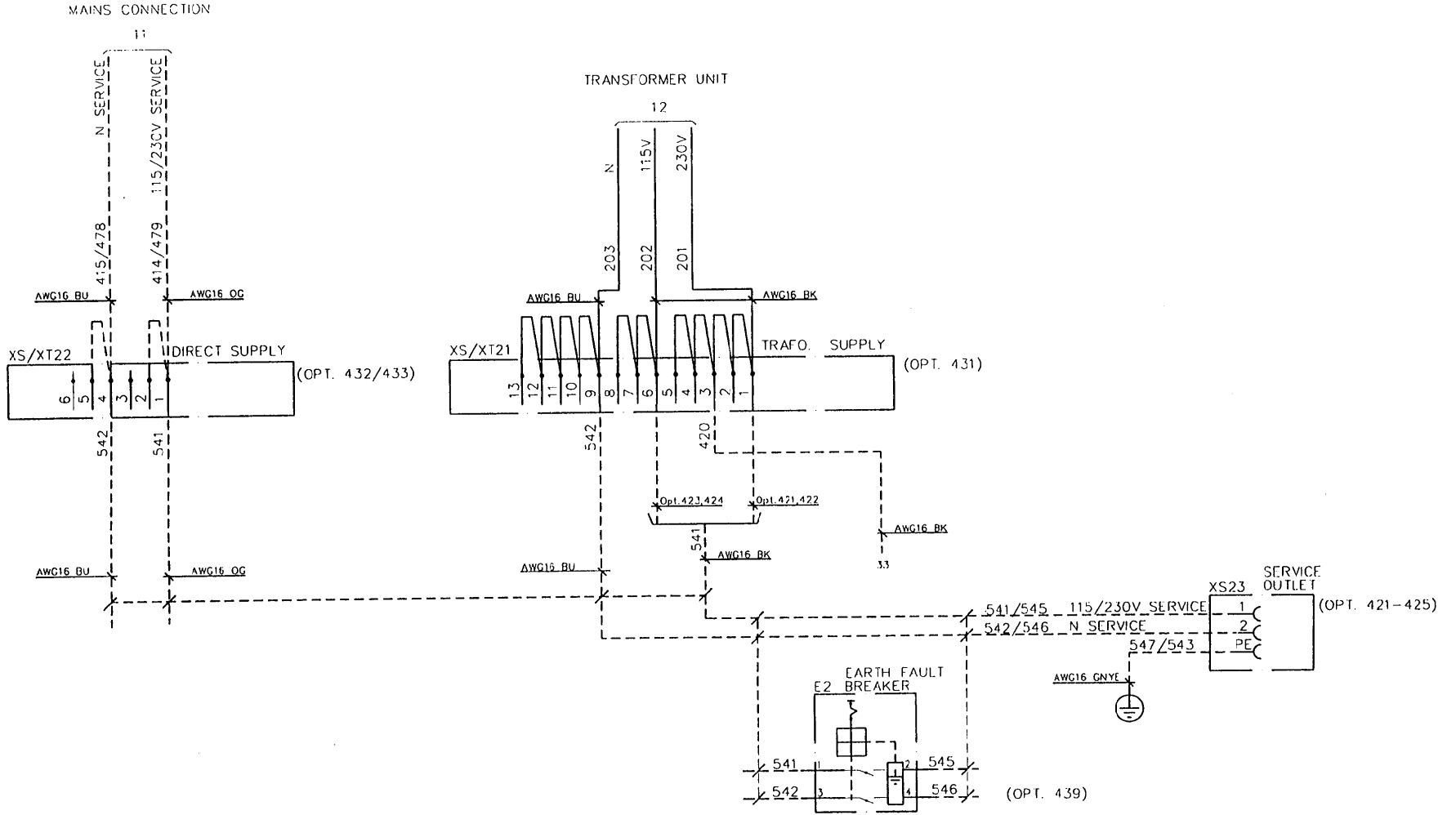

Service equipment supply

Sheet	21
No. of sh.	54

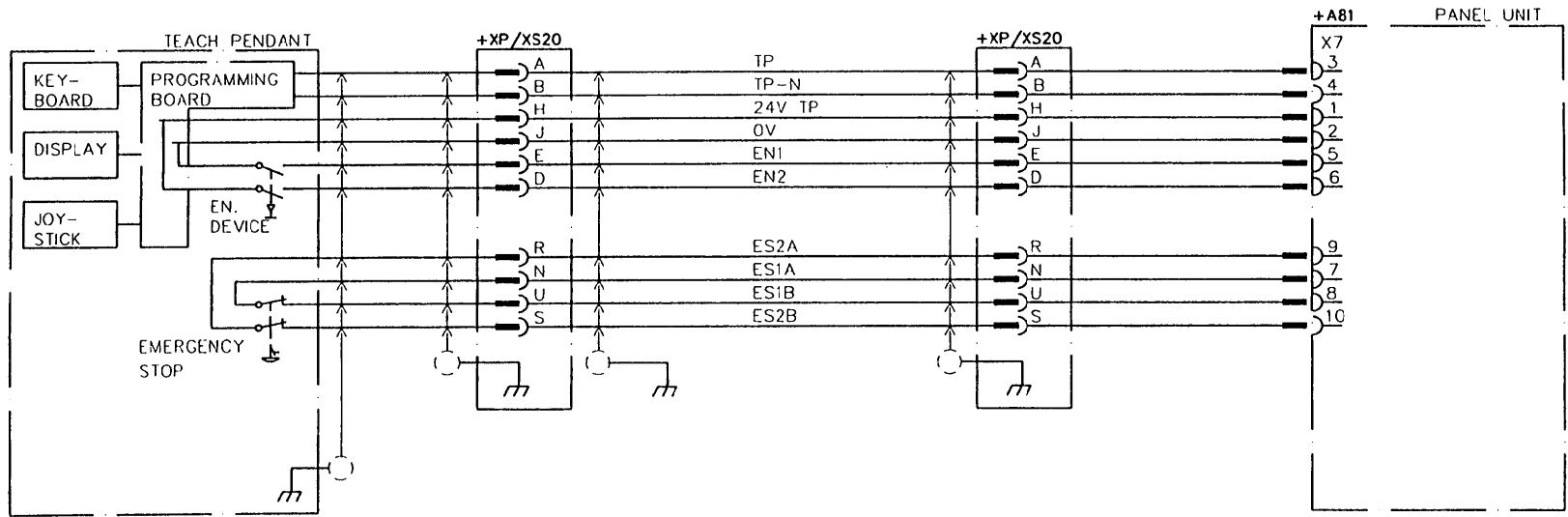

Extension cable teach pendant

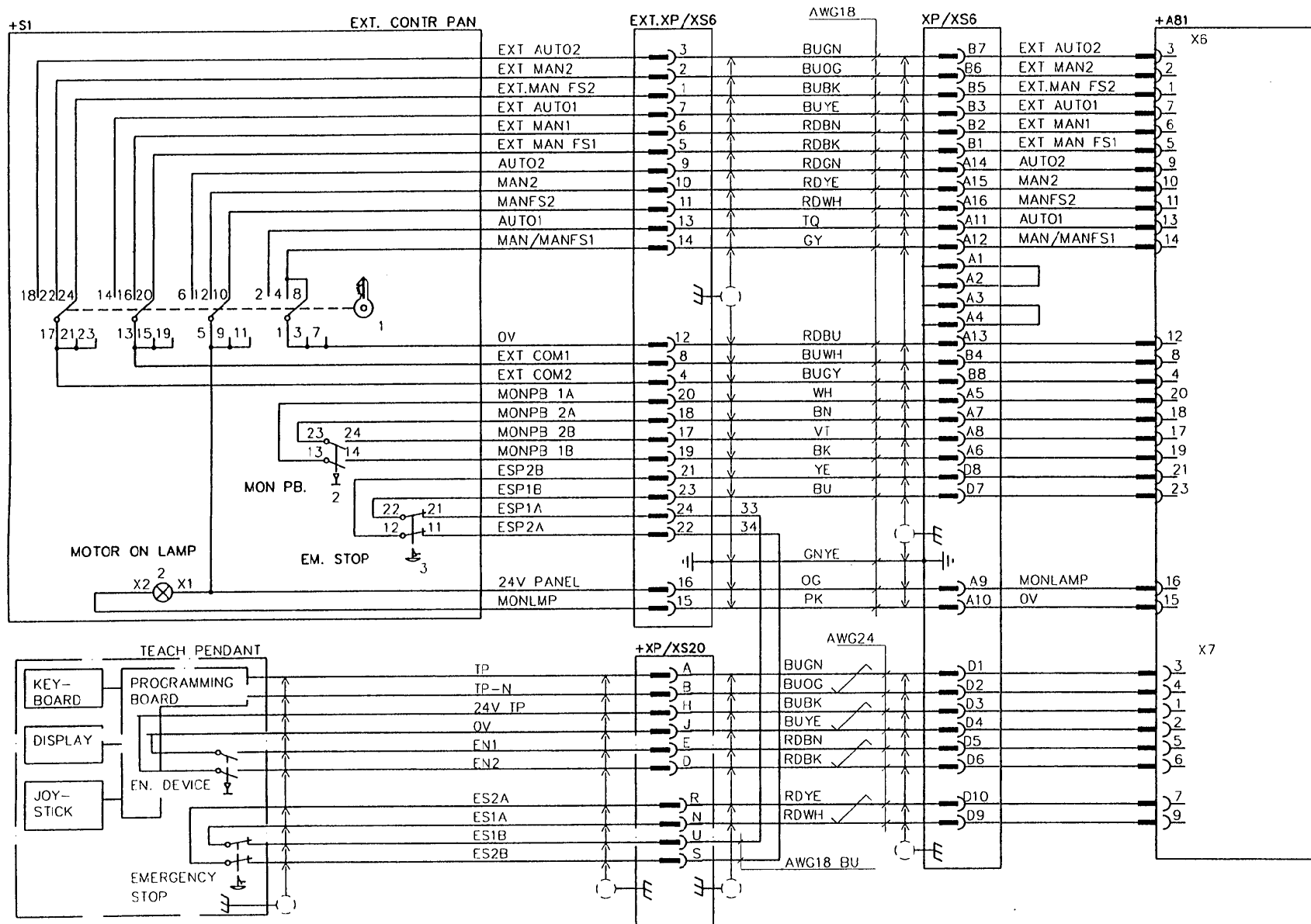

External control panel

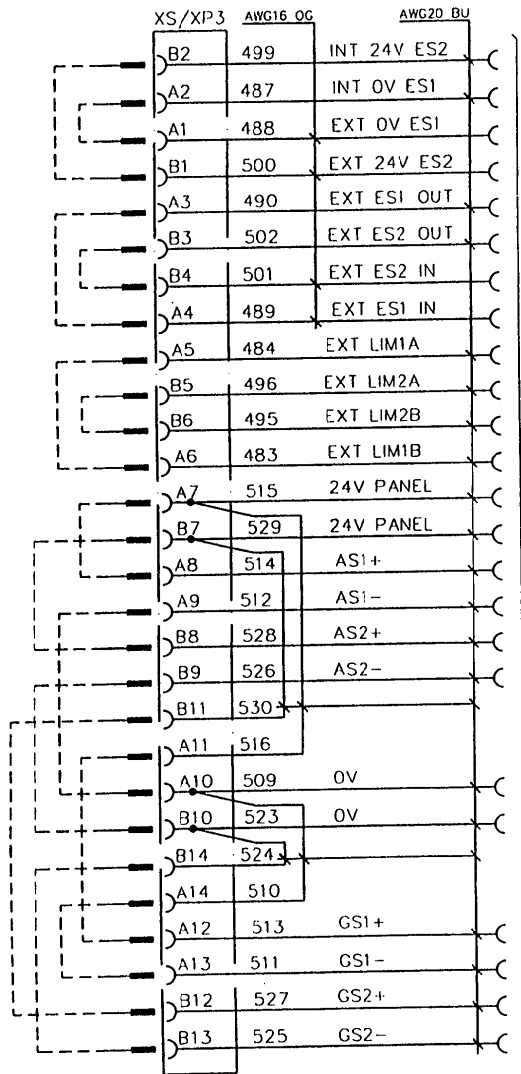

External Customer Connection

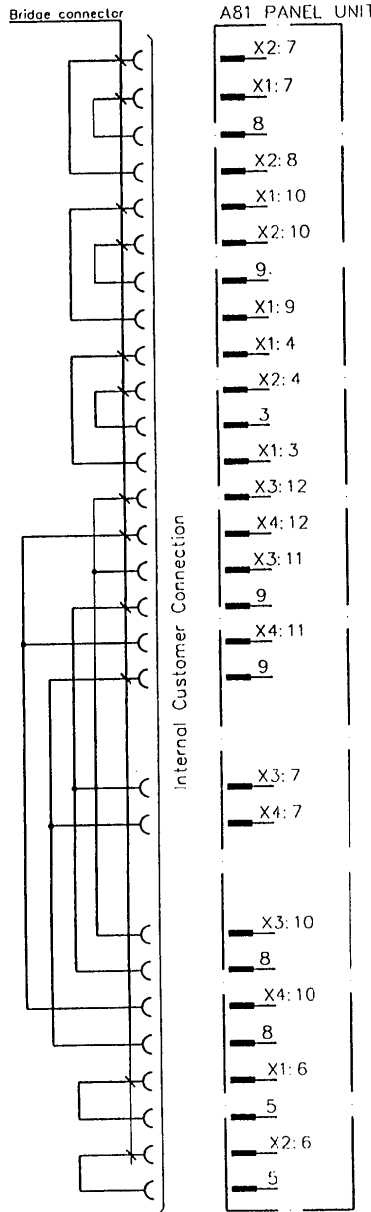

Internal Customer Connection

External/internal customer connection

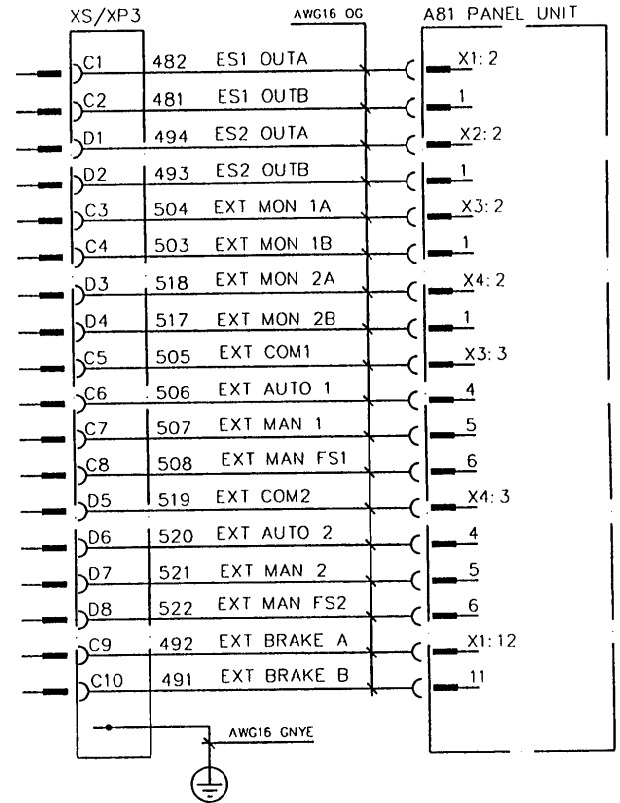

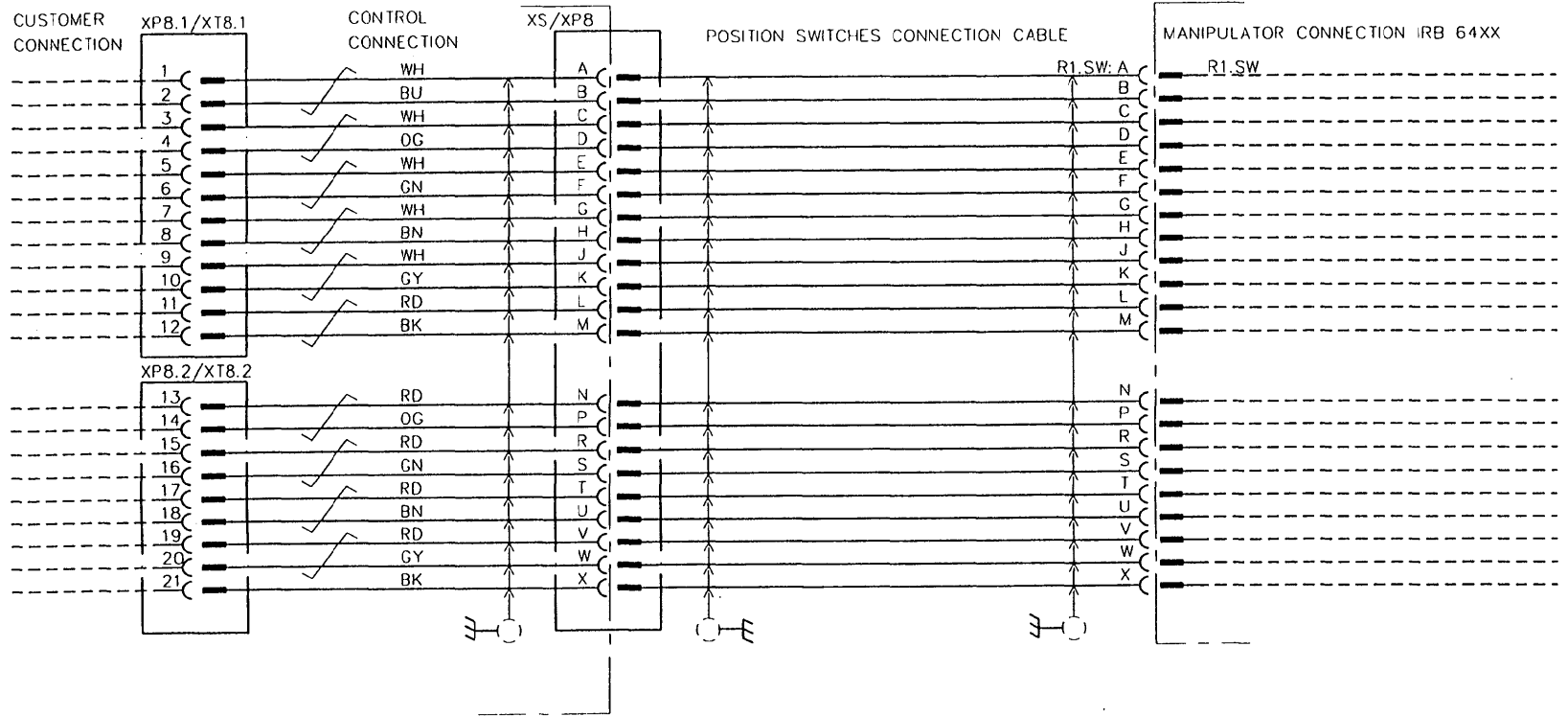
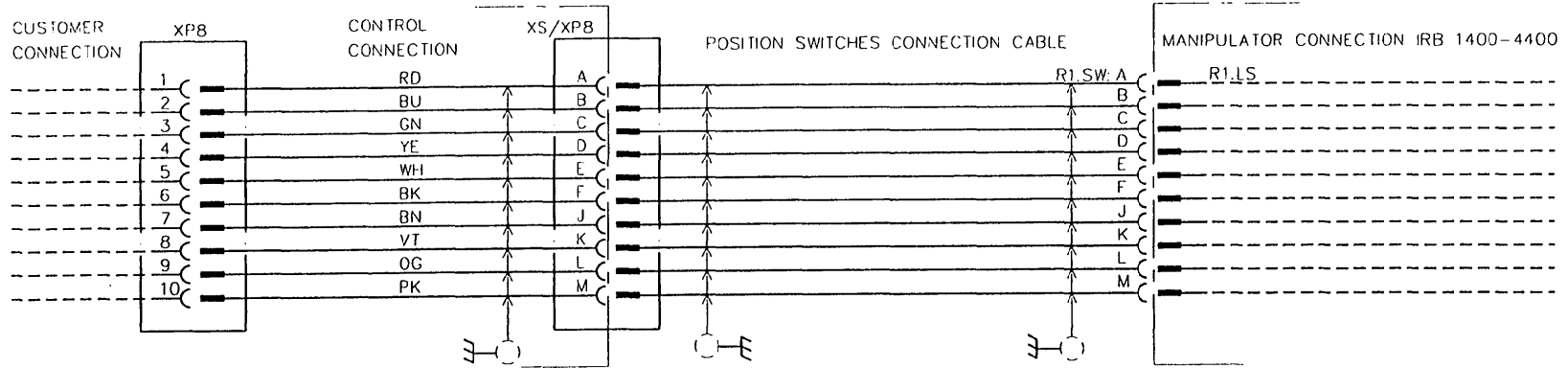

Optional position switches on manipulator

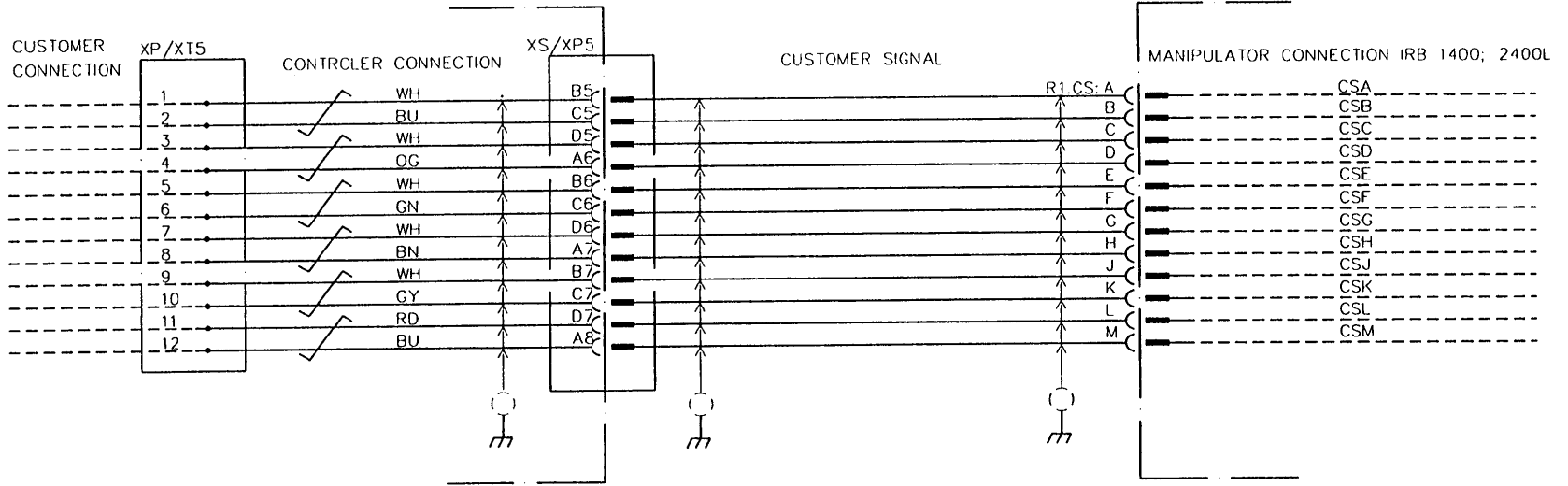

Optional customer signal IRB 1400 and IRB 2400L

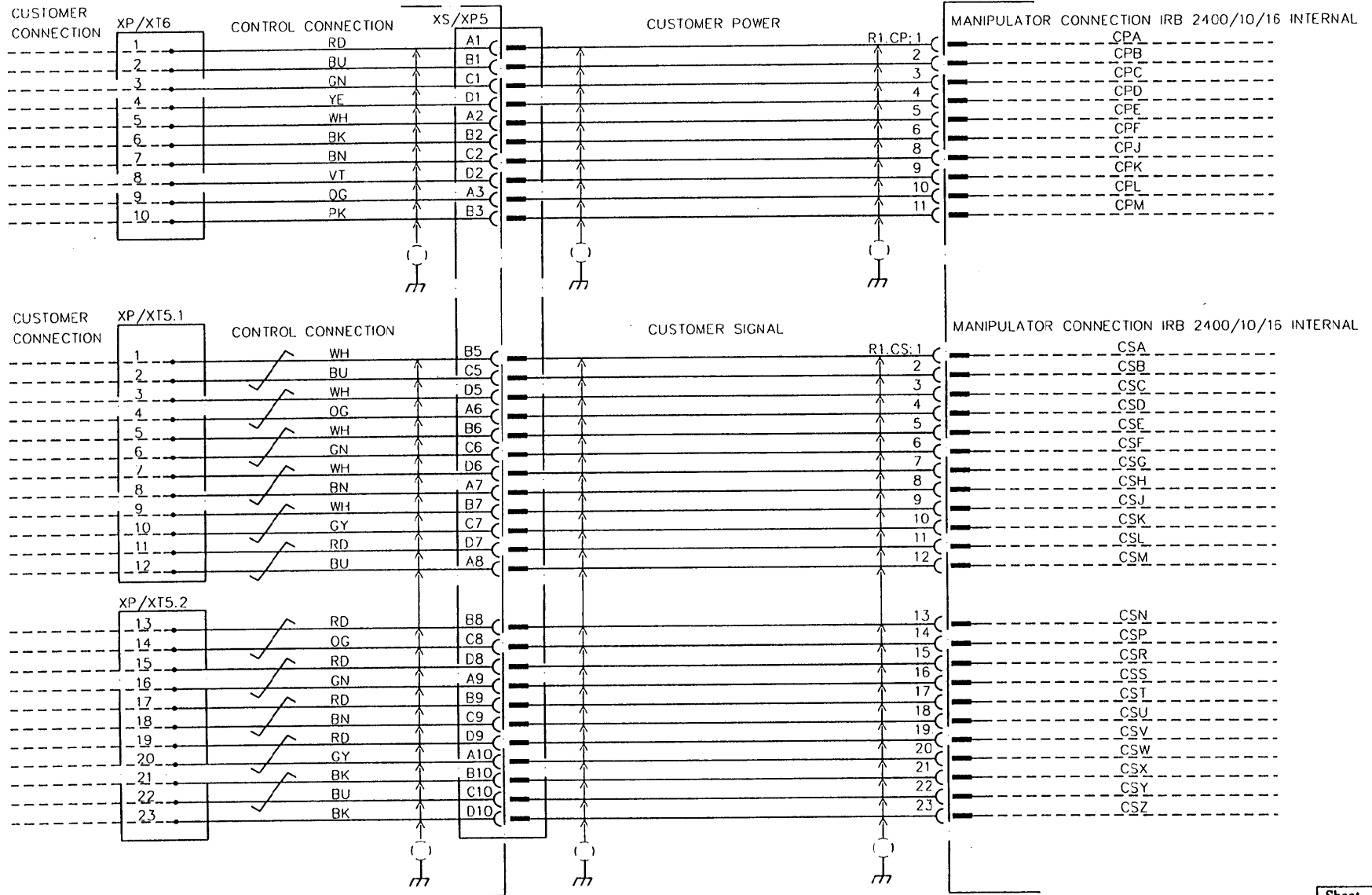

Optional customer power/signal, IRB 2400/10, /16, internal connection

Sheet	32.1
No. of sh.	54

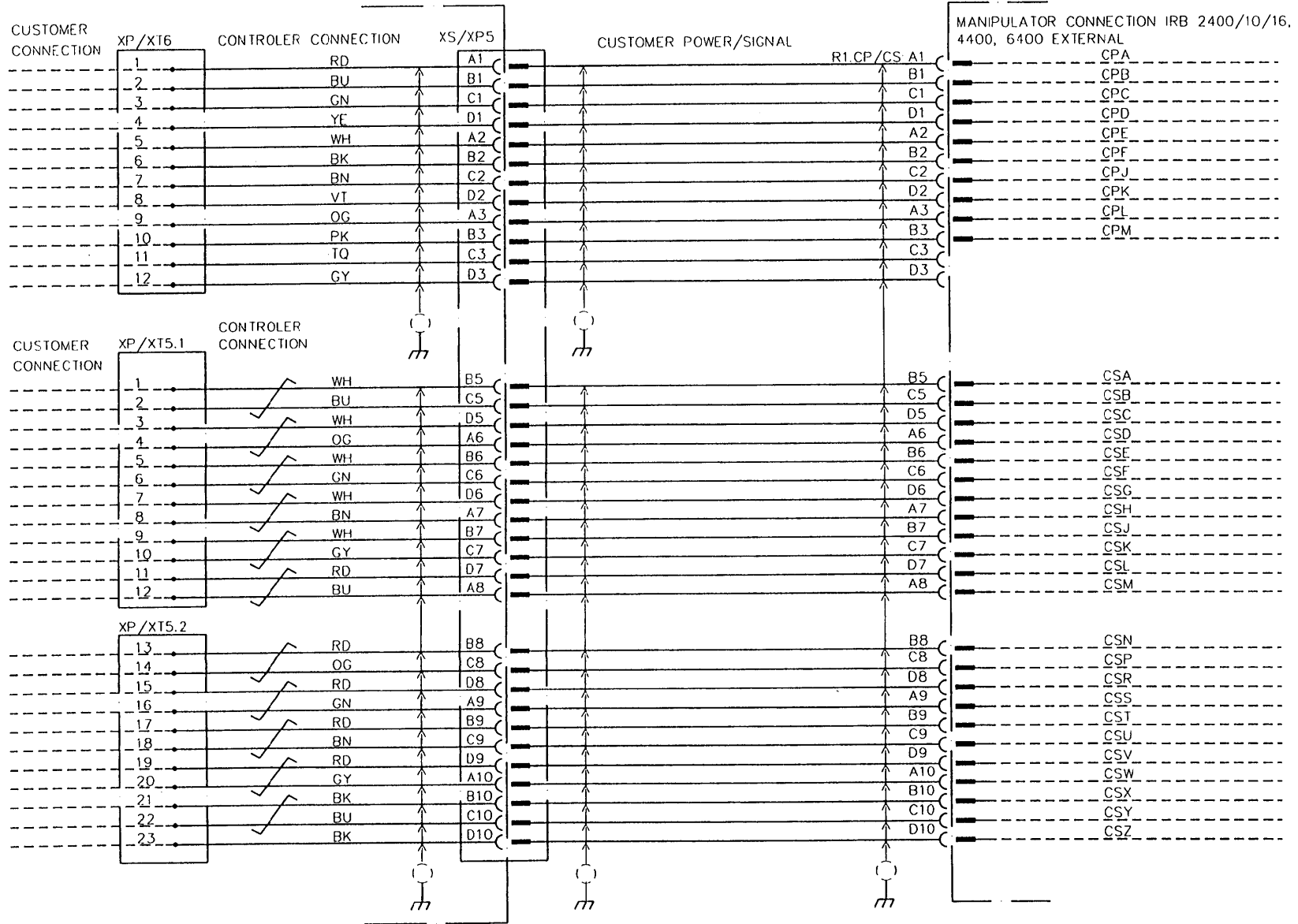

Optional customer power/signal IRB 2400/10, /16, 4400, 6400 ext. connection

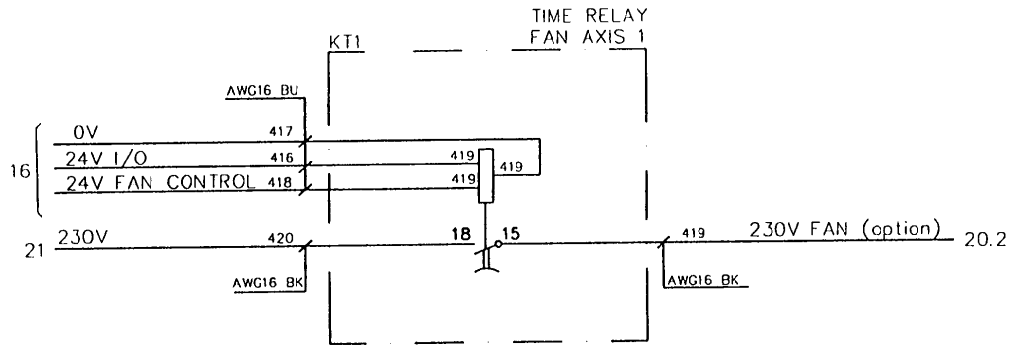

Time relay

Sheet
33
No. of sh.
54

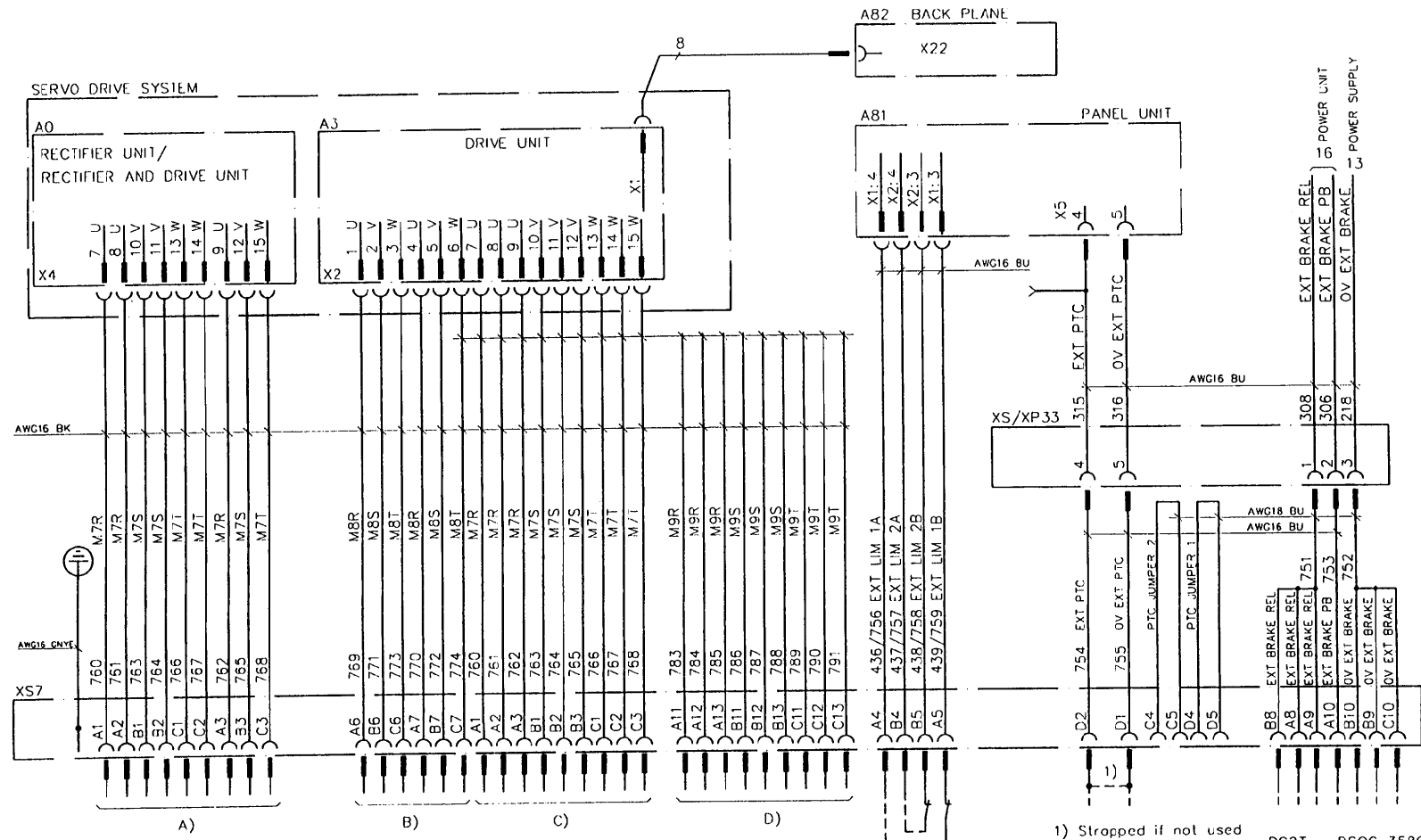

ROBOT TYPE	A0 - Rectifier and 7th	A3= 7-8th	A3= 8-9th
IRB 1400/H/B	DC2C/T	-	GT
IRB 1400/H/B	-	GT	-
IRB 2400I /1C/16	DC2C/T	-	GT
IRB 2400I /1C/16	-	GT	-
IRB 4400, 6400	DC2C/T	-	-
IRB 640	2) DC3	GT	-

- A) One external axes 7th
- B) and C) Two external axes 7-8th
- A),B) and D) Three external axes 7-9th
- 2) Only Rectifier

LIMIT SWITCH EXT. AXIS
(Strapped if not used)

1) Strapped if not used

DC2T = DSQC 358C/3HAB B101-10
 DC2 = DSQC 345C/ -3
 DC3 = DSQC 345D/ -4
 GT = DSQC 346G/ -8

External axis 7th -9th, control signal connection

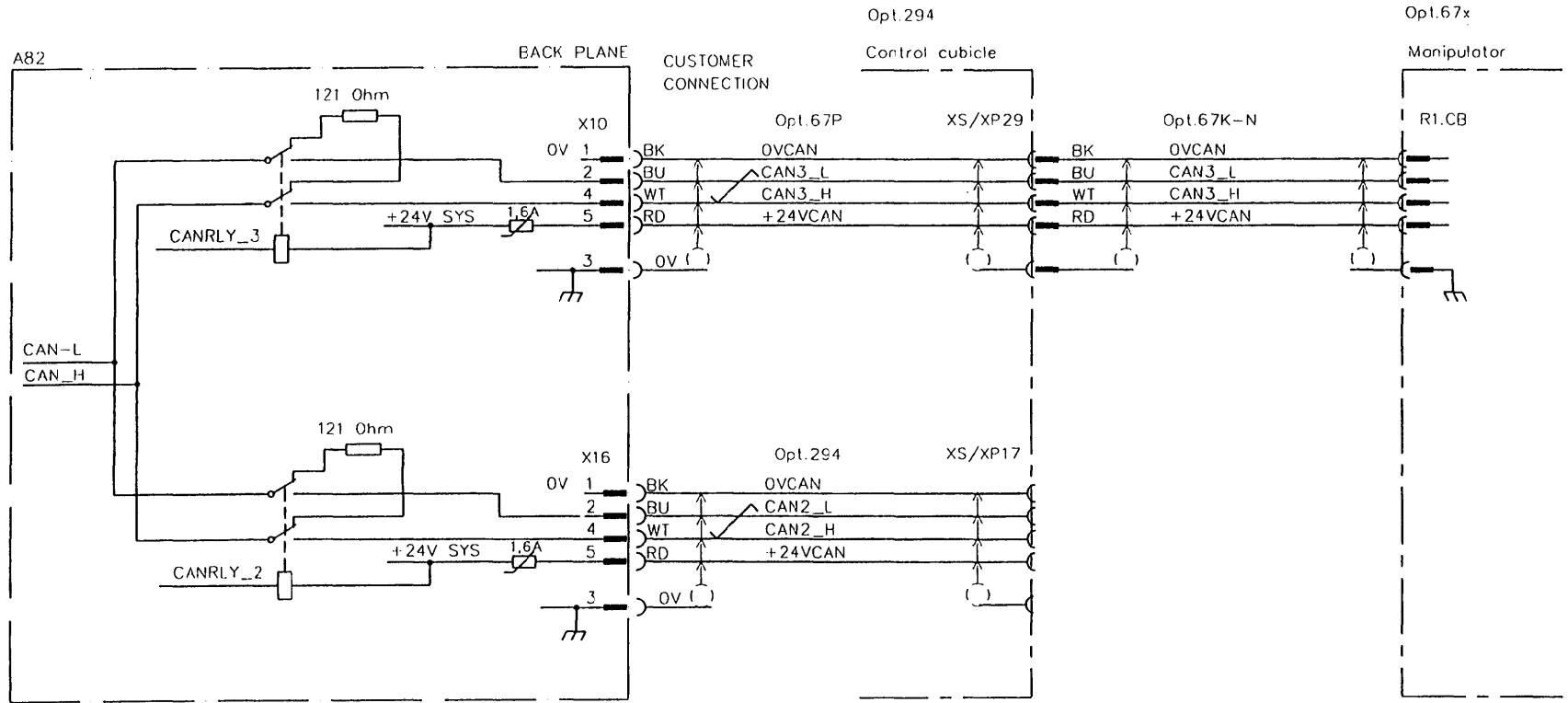

External I/O CAN-bus connection

Sheet	40
No. of sh.	54

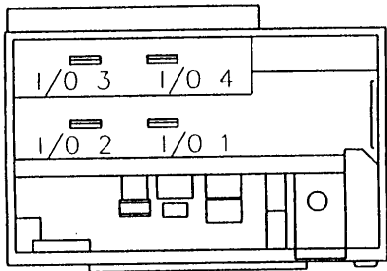
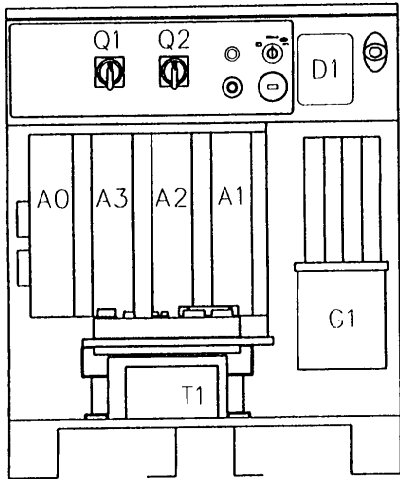

OPTIONAL I/O UNITS IN CONTROL SYSTEM S4C

I/O UNITS POSITION	I/O UNITS DESIGNATION	JUMPERS X5	NODE ADDRESS
1	I/01	6-7-9-11-12	10
2	I/02	6-9-11-12	11
3	I/03	6-7-8-11-12	12
4	I/04	6-8-11-12	13

I/O unit position

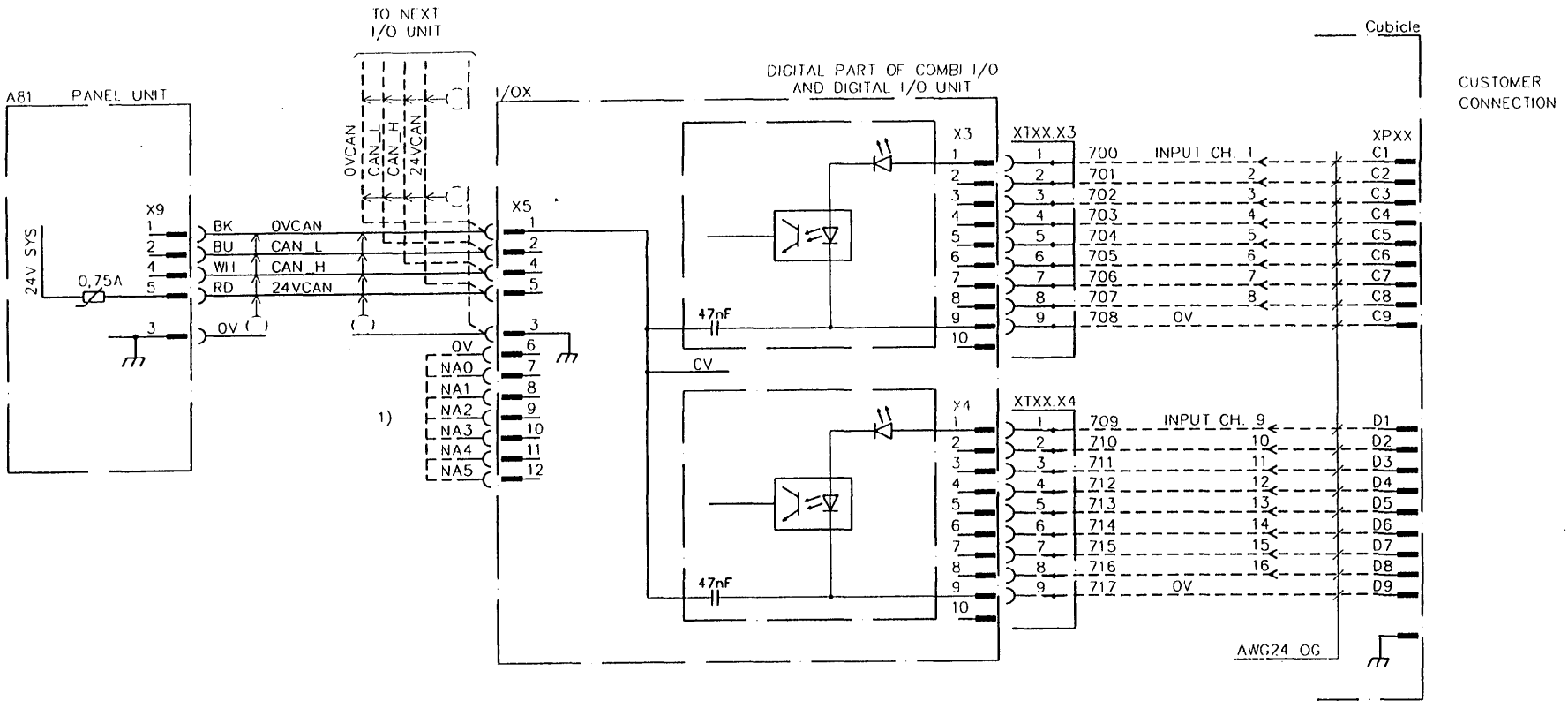

1) JUMPERS PLACED ACCORDING TO THE ACTUAL NODE ADDRESS

Digital part of combi I/O and digital I/O unit input part

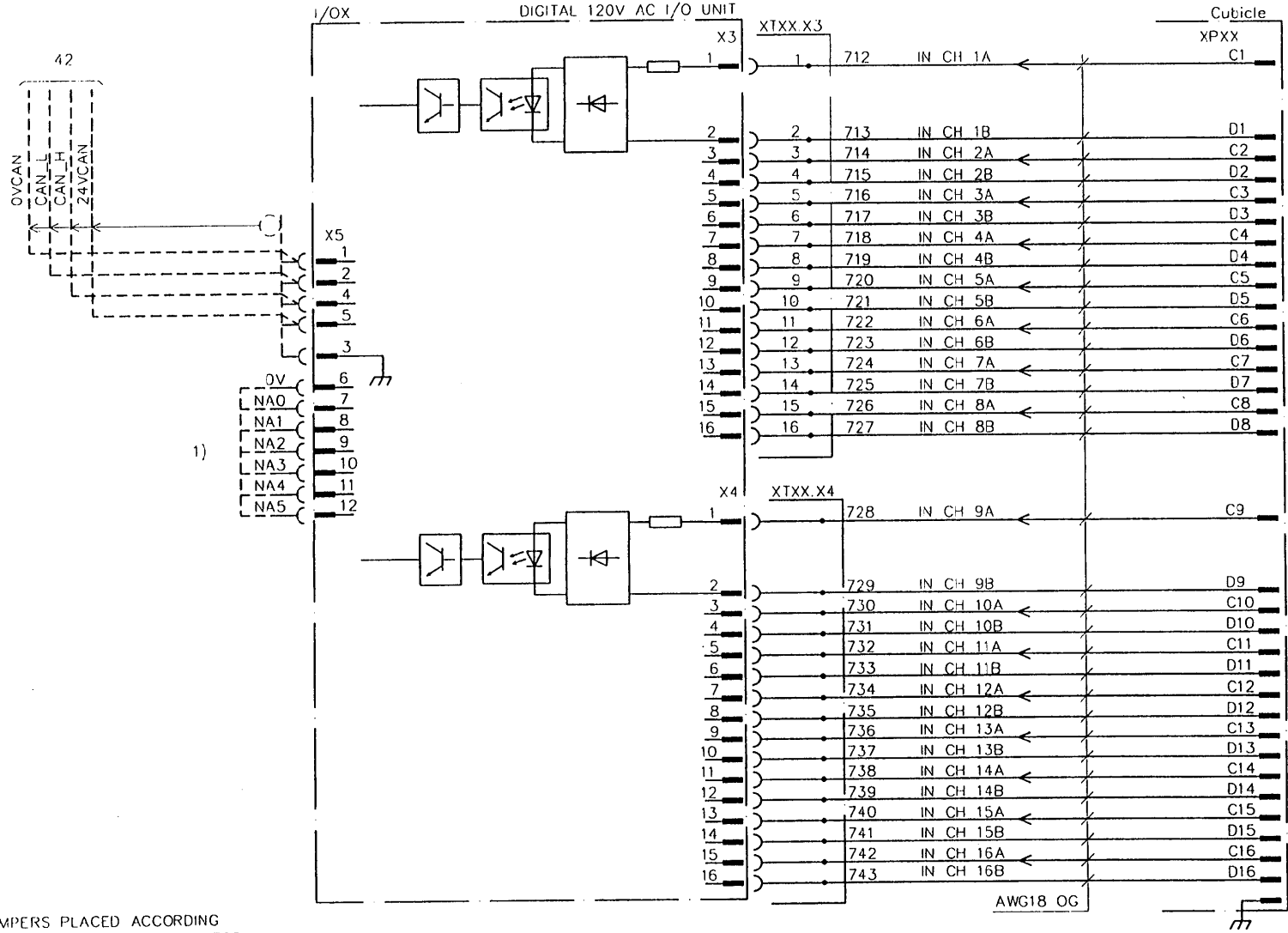

1) JUMPERS PLACED ACCORDING TO THE ACTUAL NODE ADDRESS

Digital part of 120V AC input

Sheet	42.1
No. of sh.	54

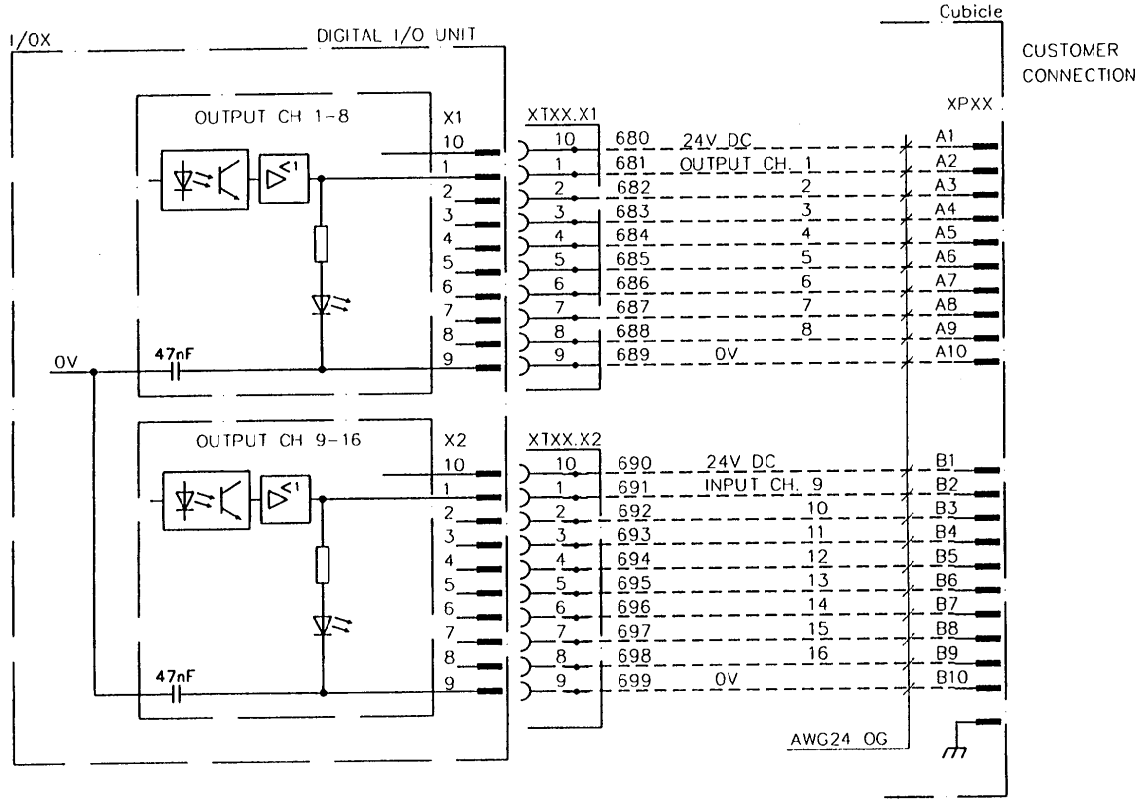

Digital I/O unit output part

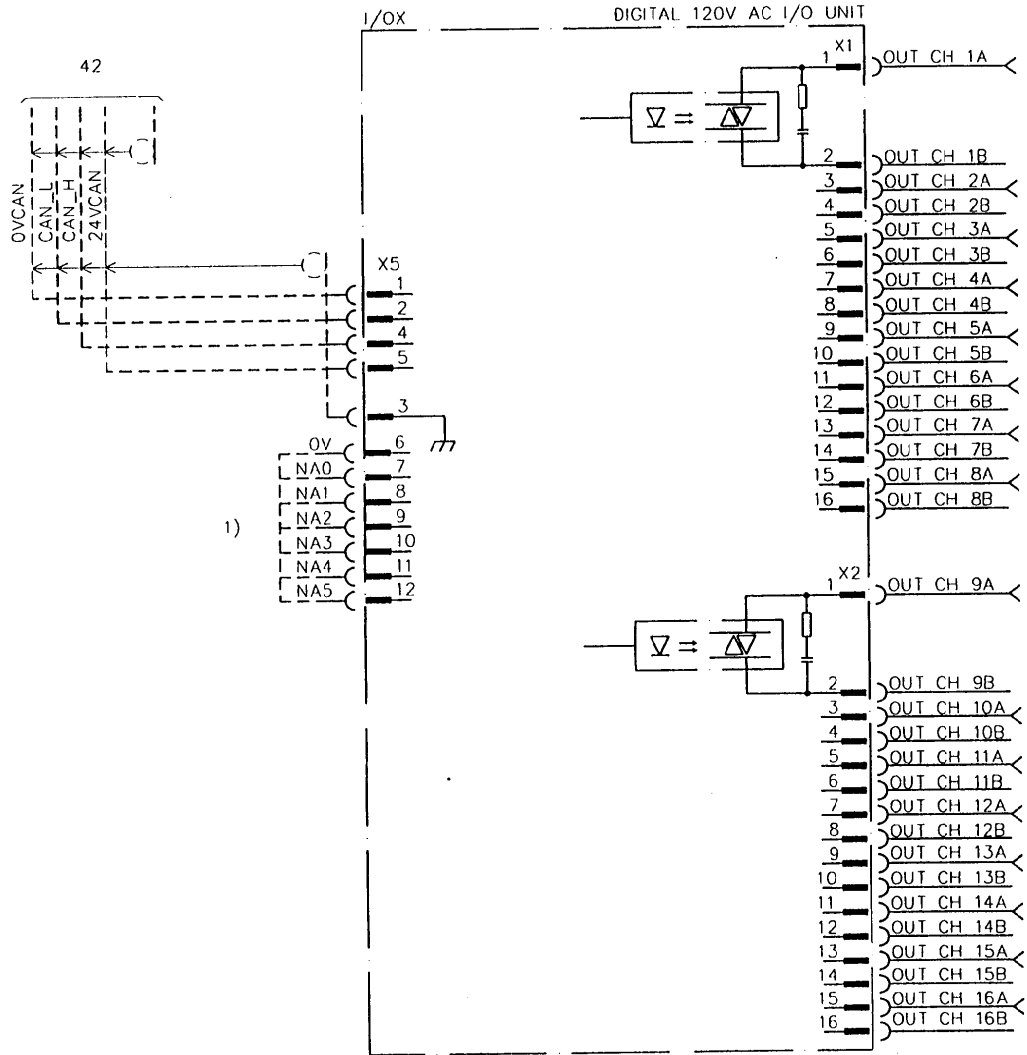

1) JUMPERS PLACED ACCORDING TO THE ACTUAL NODE ADDRESS

Digital output part of 120V AC I/O unit

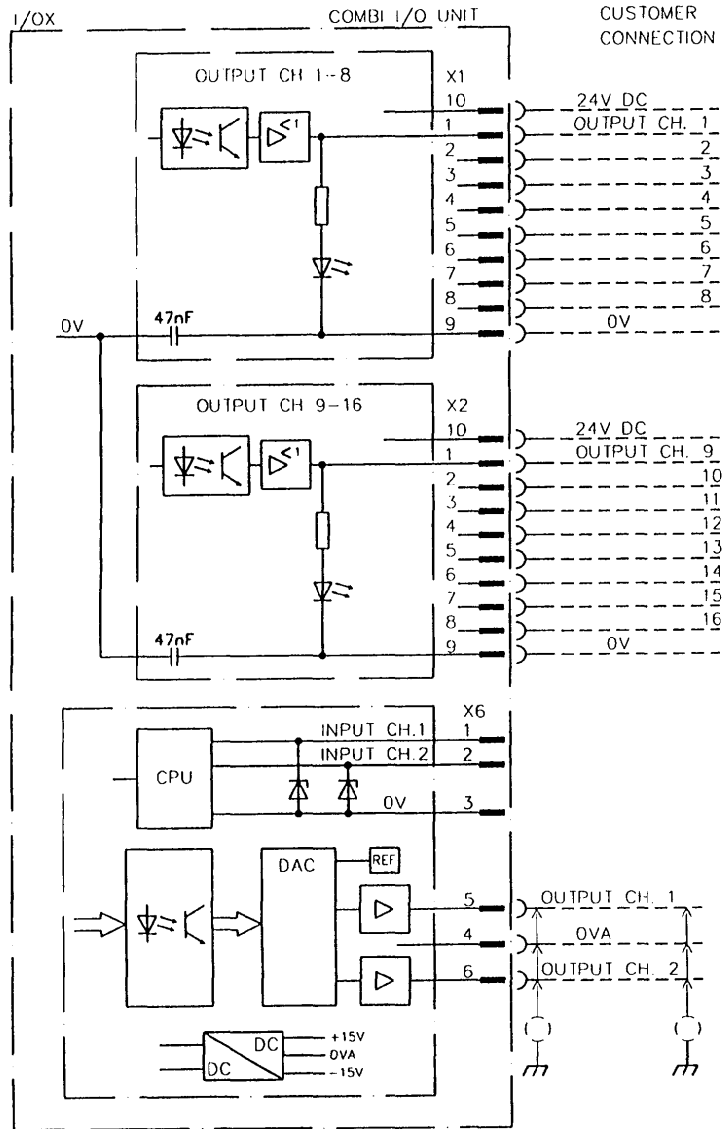

Combi I/O unit digital and analogue output part

Sheet	44
No. of sh.	54

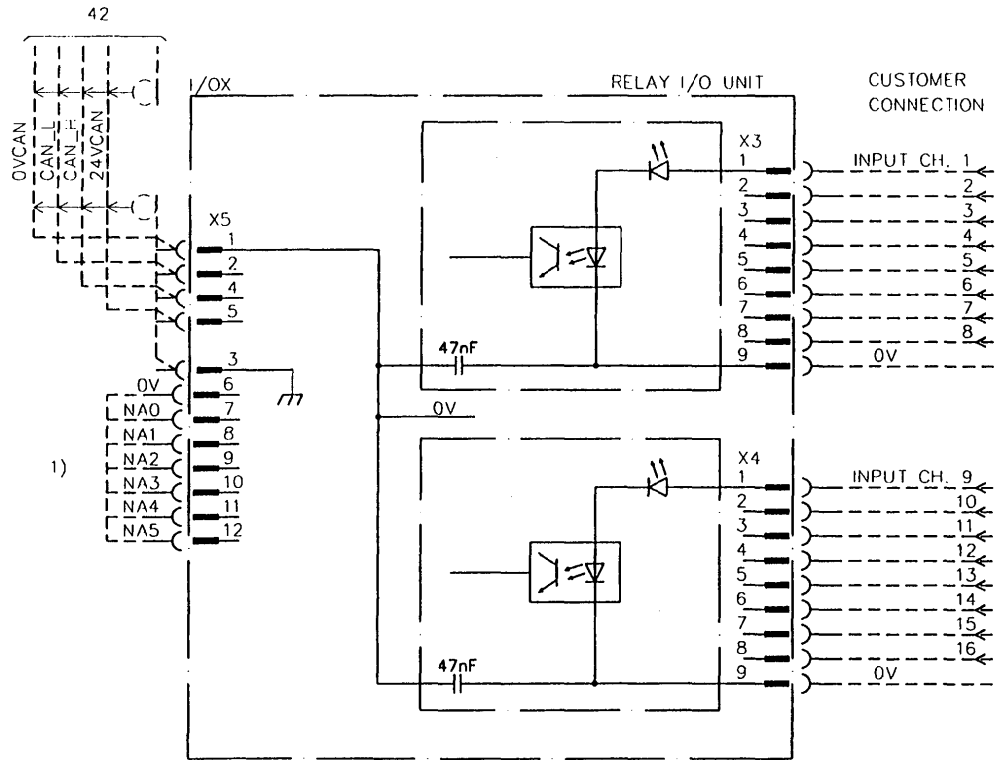

1) JUMPERS PLACED ACCORDING TO THE ACTUAL NODE ADDRESS

Relay I/O unit, input 1-16

Sheet	45
No. of sh.	54

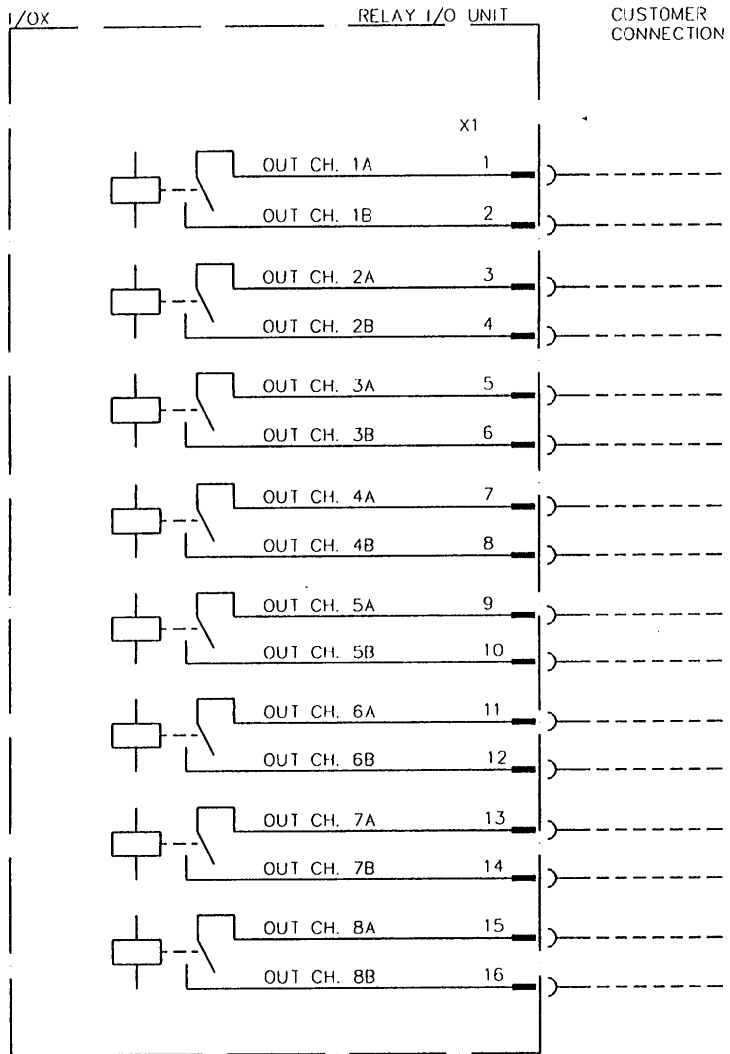

Digital with relays I/O output 1-8

Sheet	46
No. of sh.	54

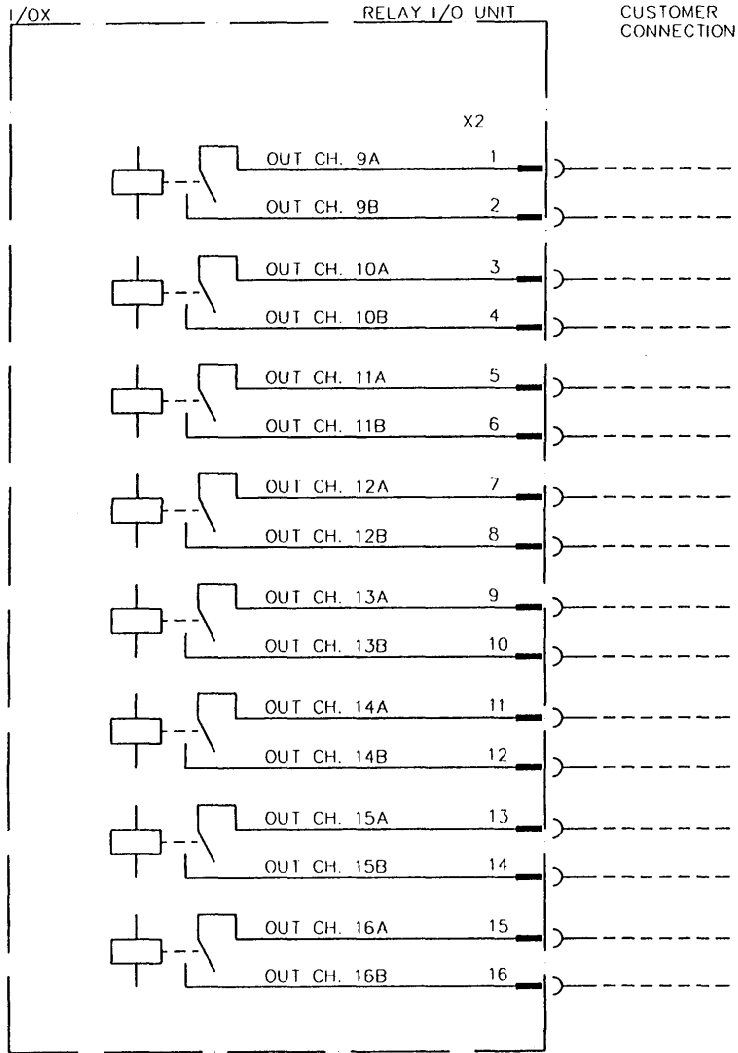

Digital with relays I/O output 9 - 16

Sheet	47
No. of sh.	54

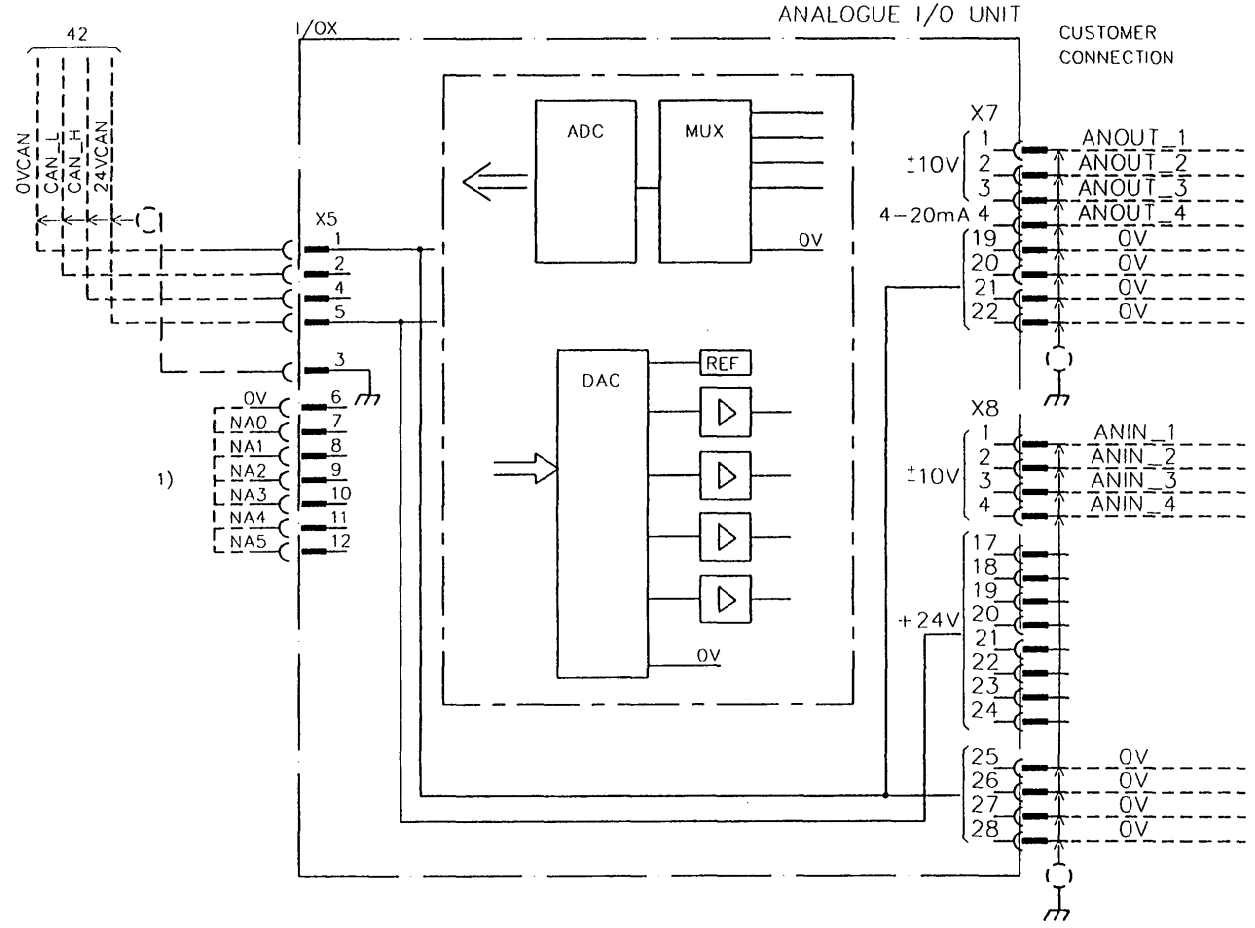

1) JUMPERS PLACED ACCORDING TO THE ACTUAL NODE ADDRESS

Analogue I/O unit

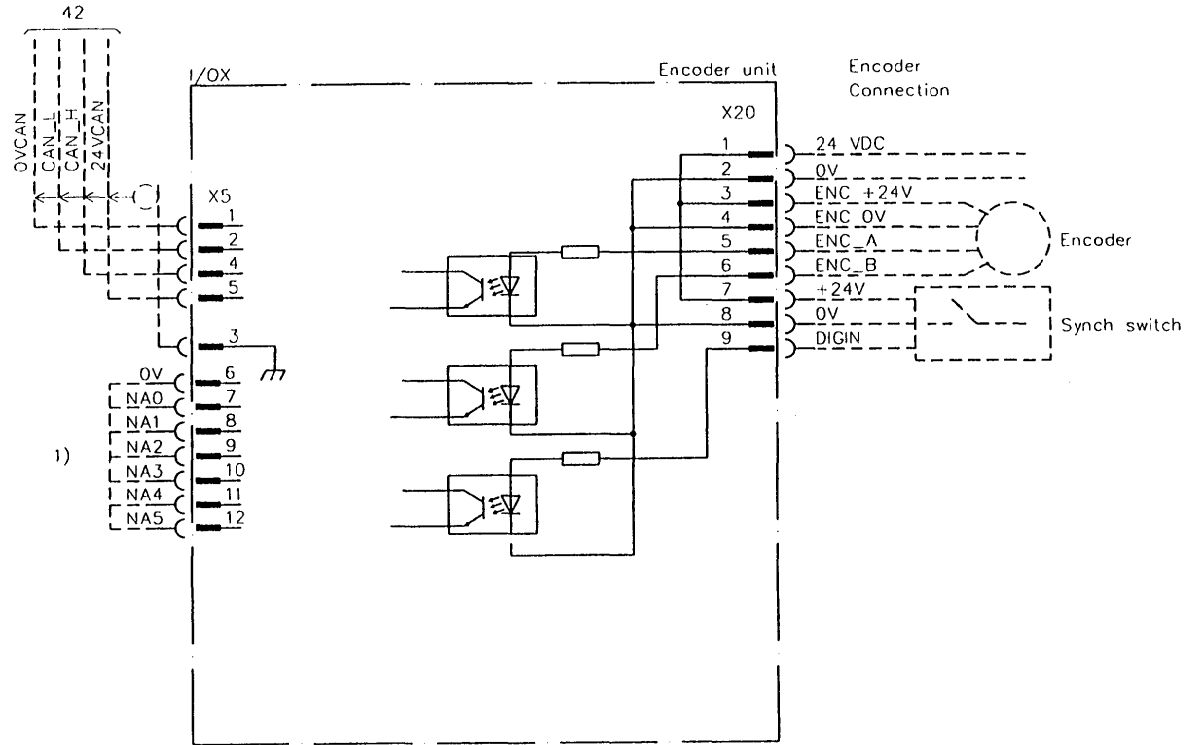

1) JUMPERS PLACED ACCORDING TO THE ACTUAL NODE ADDRESS

Encoder unit

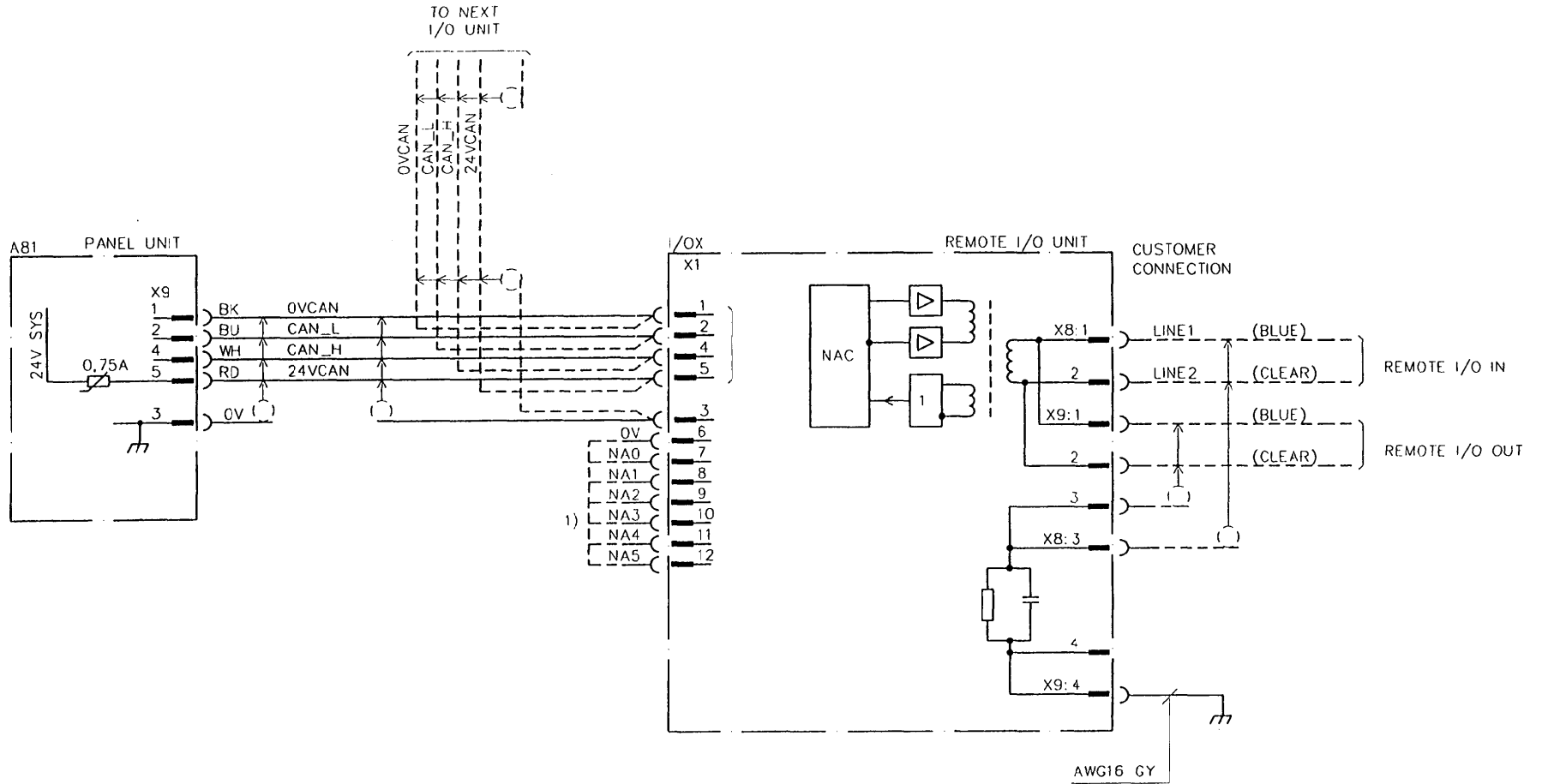

1) JUMPERS PLACED ACCORDING TO THE ACTUAL NODE ADDRESS

Remote I/O unit for Allen Bradly PLC

Sheet	70
No. of sh.	54

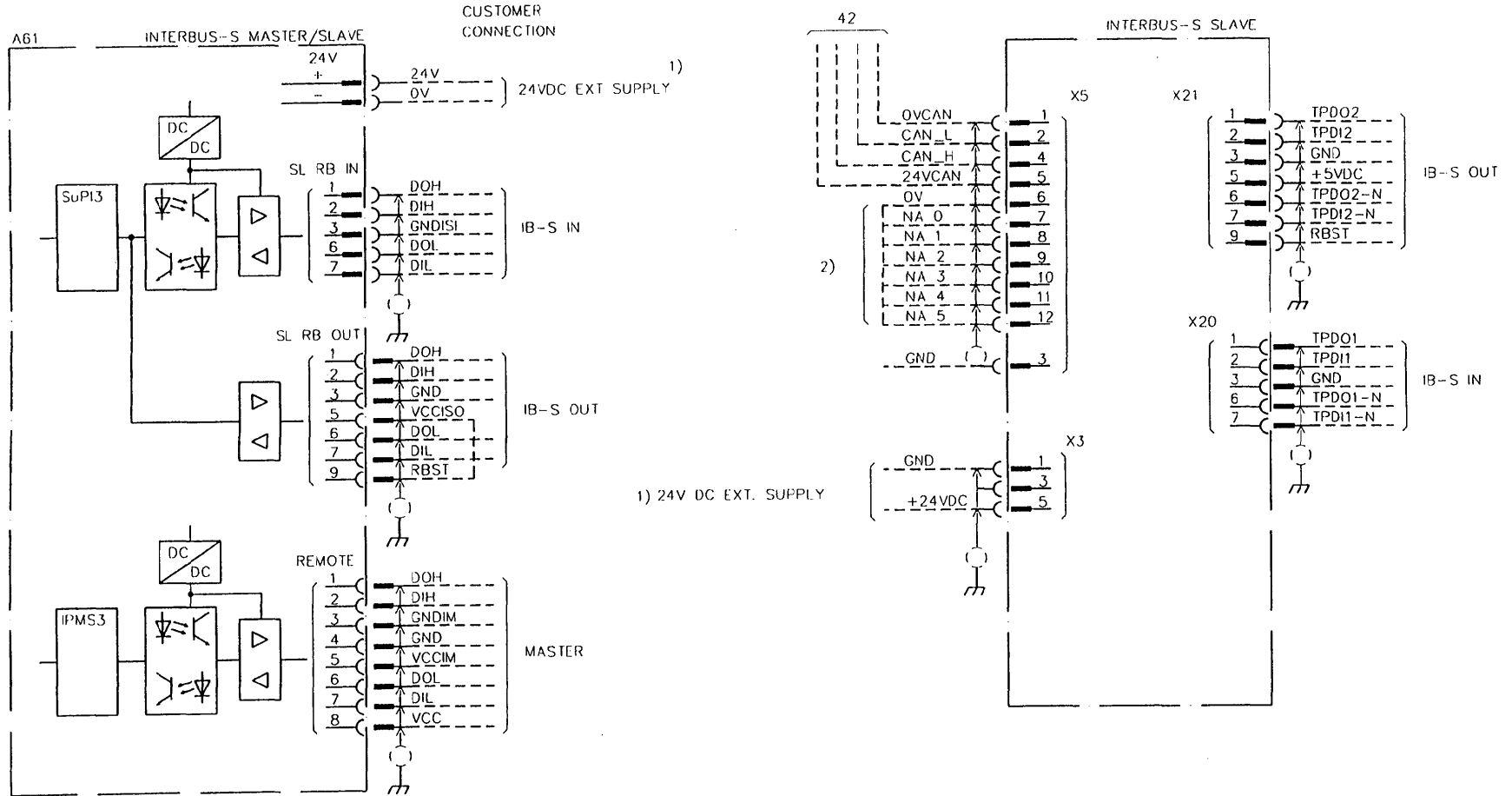

1) IT IS IMPORTANT THAT 24V DC EXT SUPPLY ALWAYS IS AVAILABLE. OTHERWISE THE INTERBUS-S CAN NOT WORK IF THE CONTROLLER IS TURNED OFF.

2) JUMPERS PLACED ACCORDING TO THE ACTUAL NODE ADDRESS

Interbus-S master/slave, Interbus-S slave

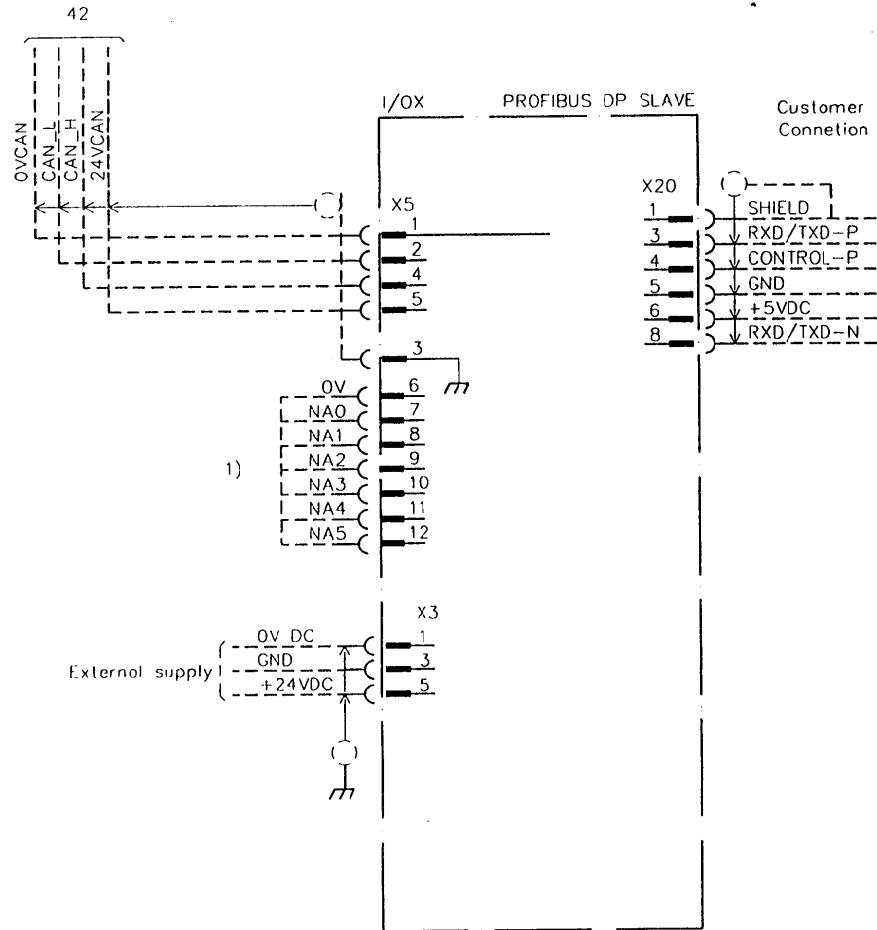





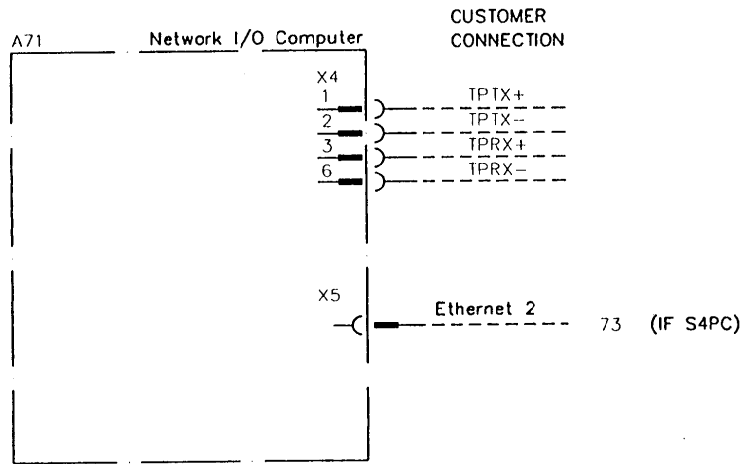

1) JUMPERS PLACED ACCORDING TO THE ACTUAL NODE ADDRESS

Profibus DP slave

Sheet	71.1
No. of sh.	54



Network I/O computer

LEGEND SYMBOLER	
	Motor Motor
	Brake Broms
	Temp. sensor (PTC-resistor) Temp. givare (PTC-motstånd)
	Resolver Resolver
	Protective earth Skyddsjord
	Twisted cables Tvinnade kablar
	Screened cables Skärmade kablar
KEY PIN/STIFT	Location pin to avoid mismatch of connector Nyckelstift för att förhindra felanslutning

SHEET BLAD	CONTENT INNEHÅLL
101	List of contents Innehållsförteckning
102	Connection point locations Översikt över delningspunkter
103	Brake release unit, Serial measuring board Bromslossningsenhet, seriemätkort
104	Motor axis 1-3 Motor axel 1-3
105	Feed-back axis 1-3 Återföringsdon axel 1-3
106	Motor axis 4-6, 1,5-10/16 Motor axel 4-6, 1,5-10/16
107	Feed-back axis 4-6, 1,5-10/16 Återföringsdon axel 4-6, 1,5-10/16
108	Motor axis 4-6, 1,8-5 Motor axel 4-6, 1,8-5
109	Feed-back axis 4-6, 1,8-5 Återföringsdon axel 4-6, 1,8-5
110	Customer connection Kundanslutning
111	Position indicator axis 1; OPTION Lägesindikering axel 1; OPTION
112	External connections; OPTION Yttre anslutningar; OPTION

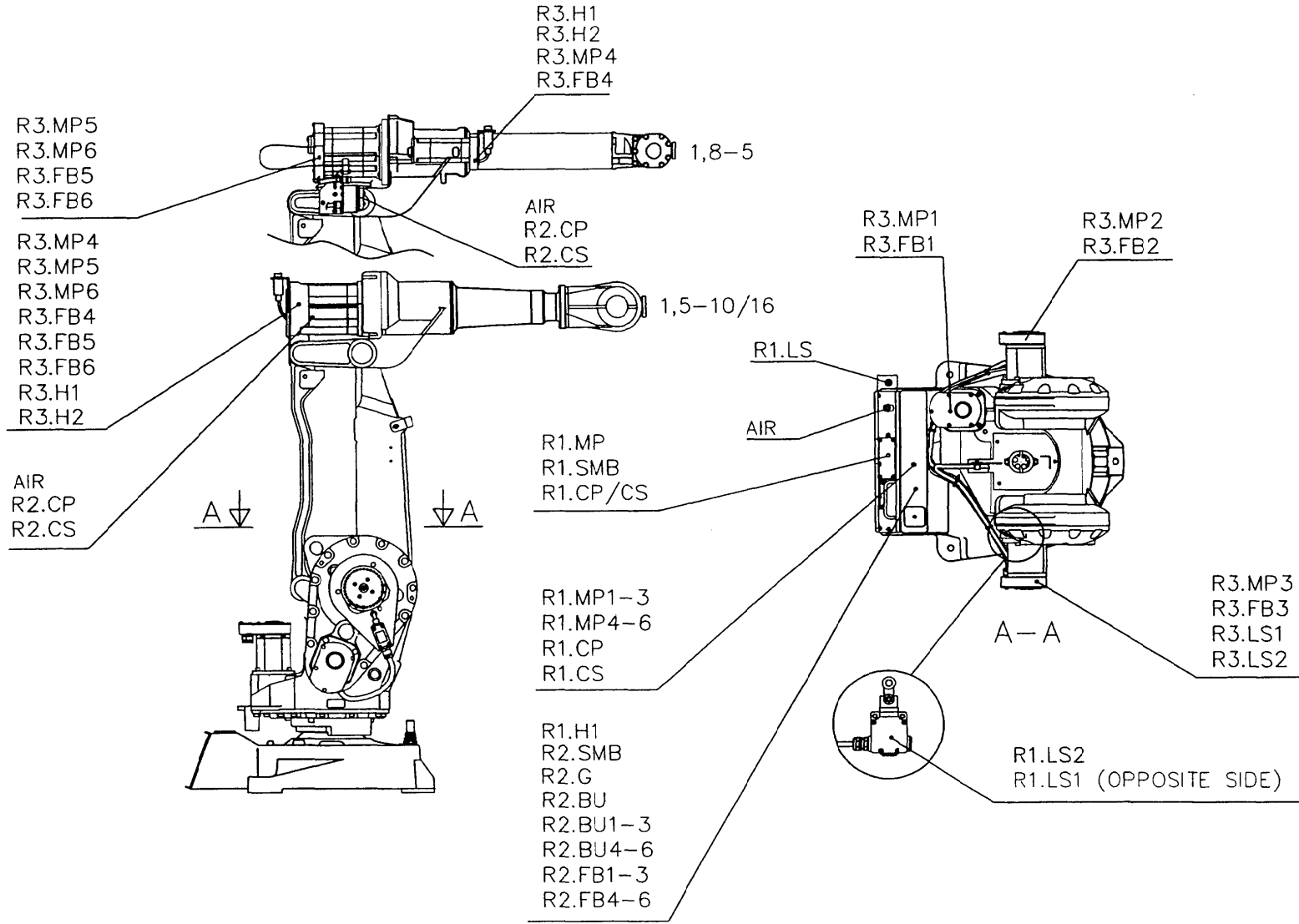

Conn. point location

Sheet	102
No. of sh.	12

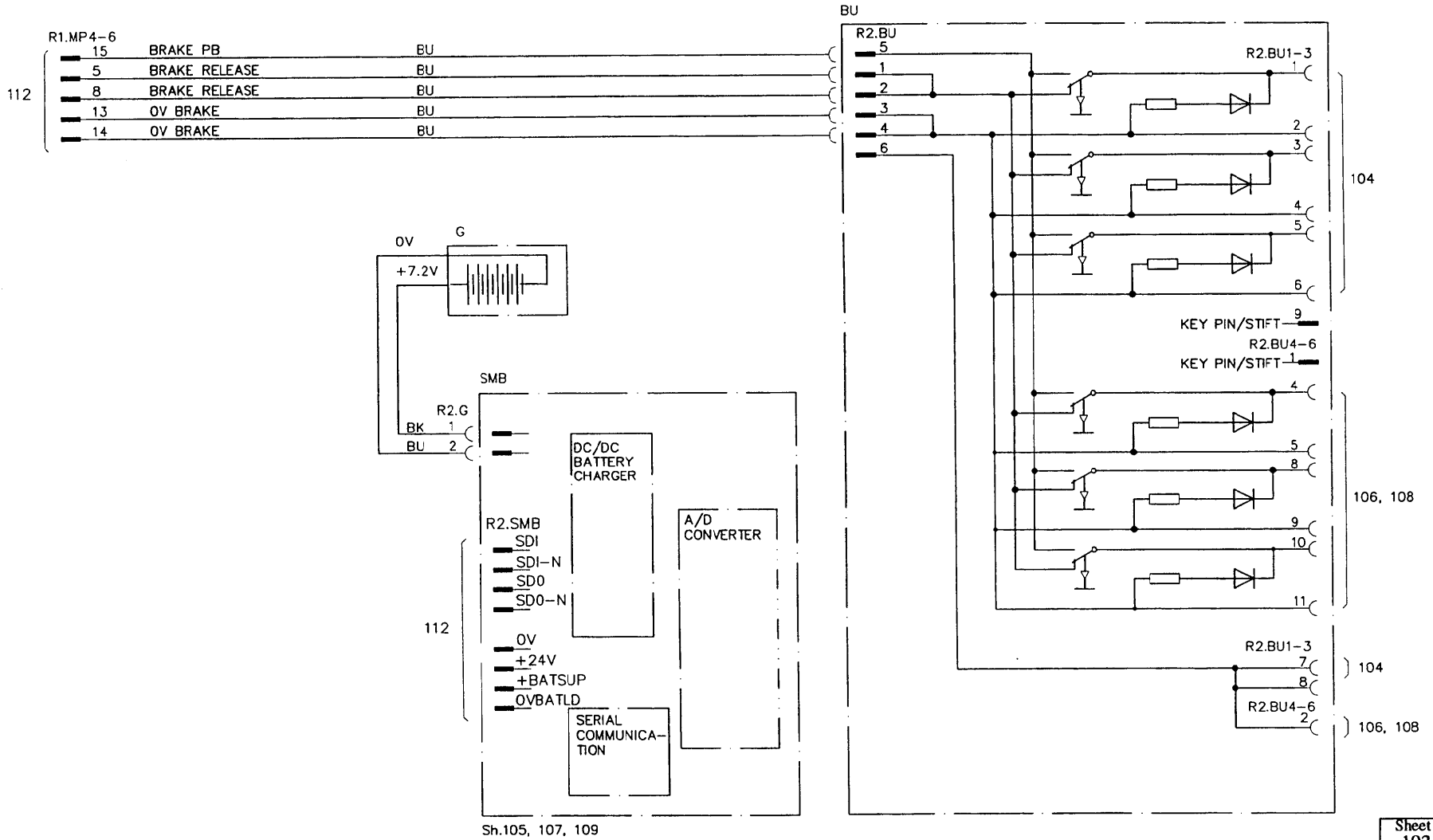

Sh.105, 107, 109

Brake unit, serial meas. board

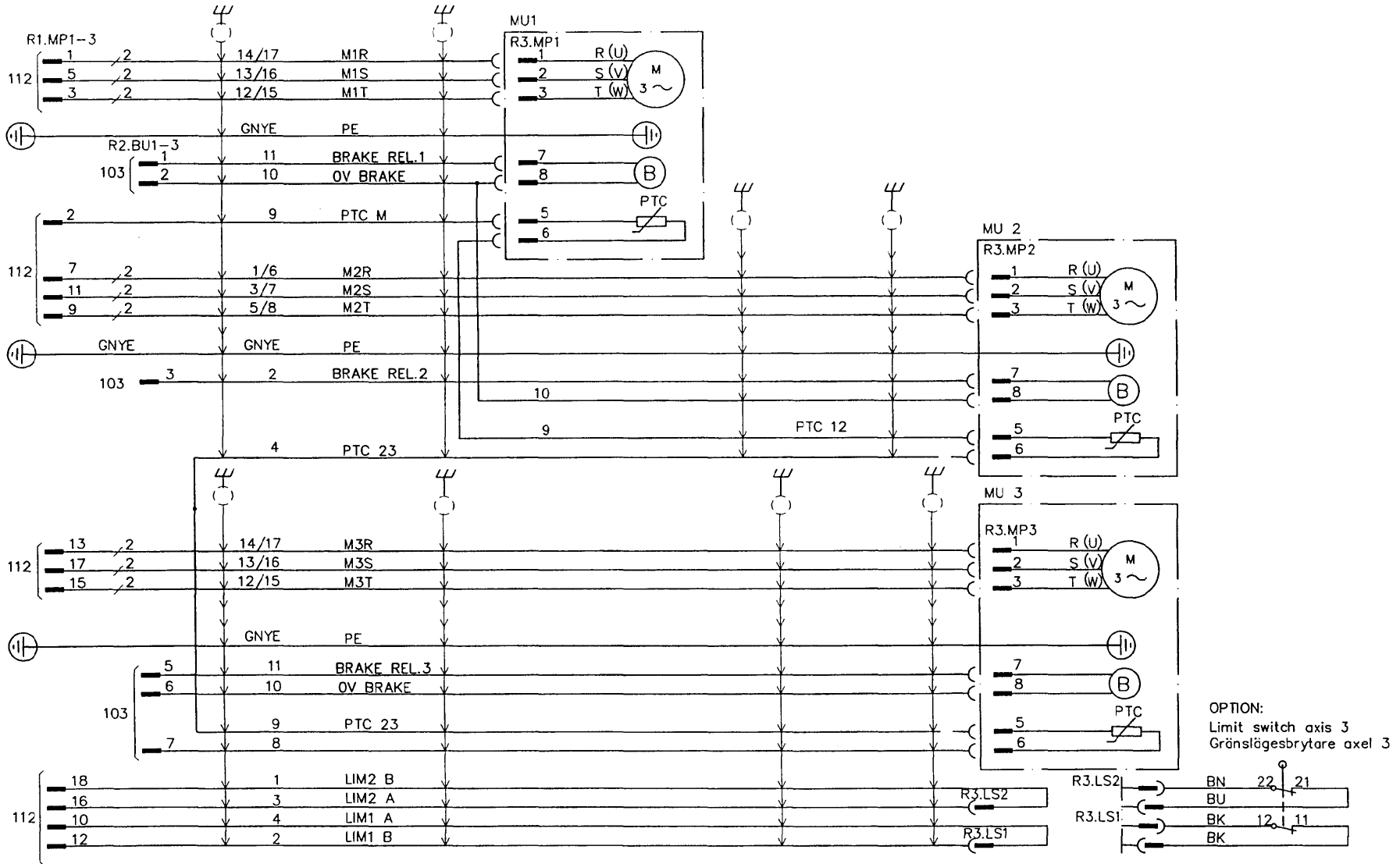

Motor axis 1-3

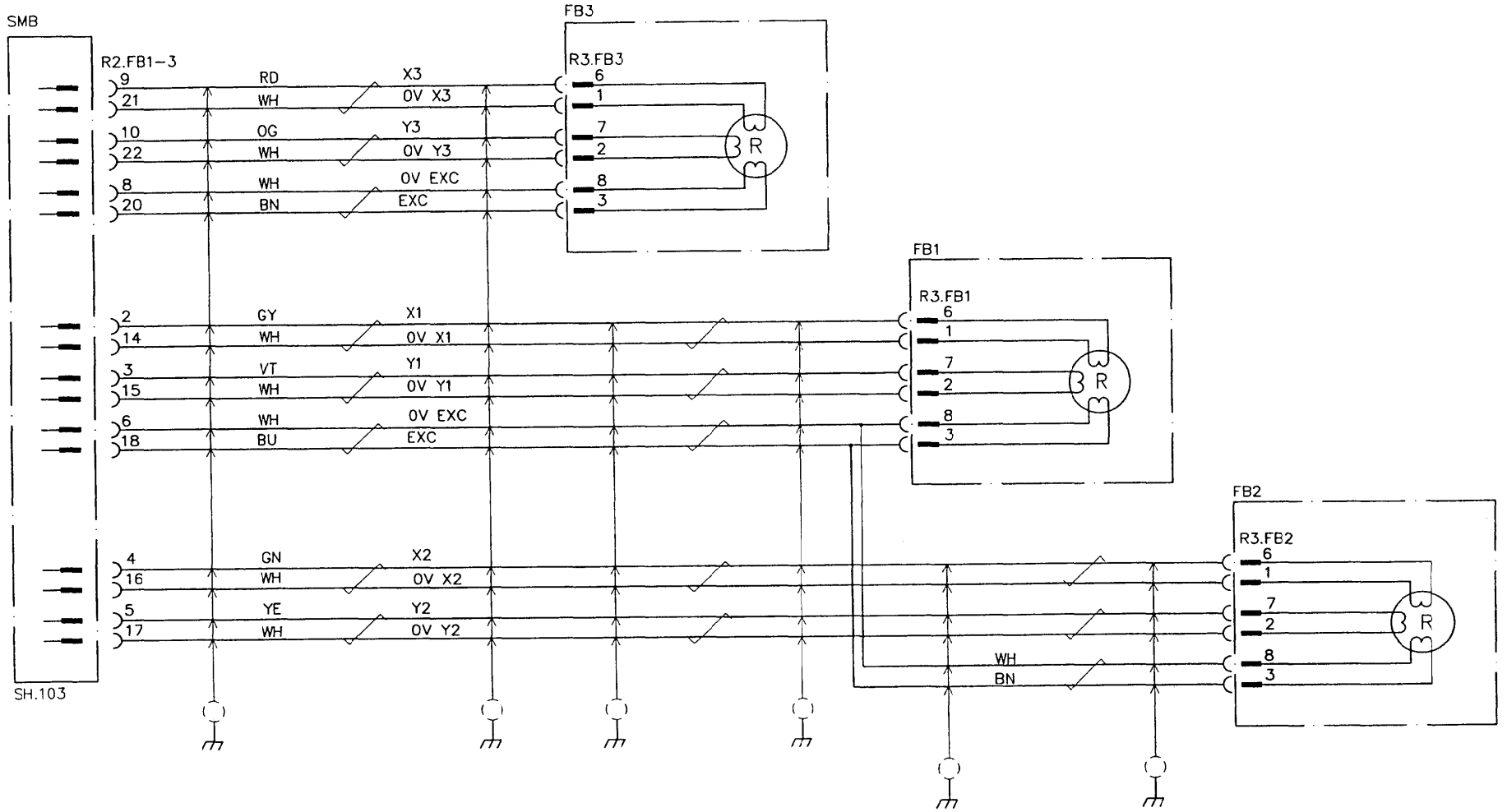

Feed-back axis 1-3

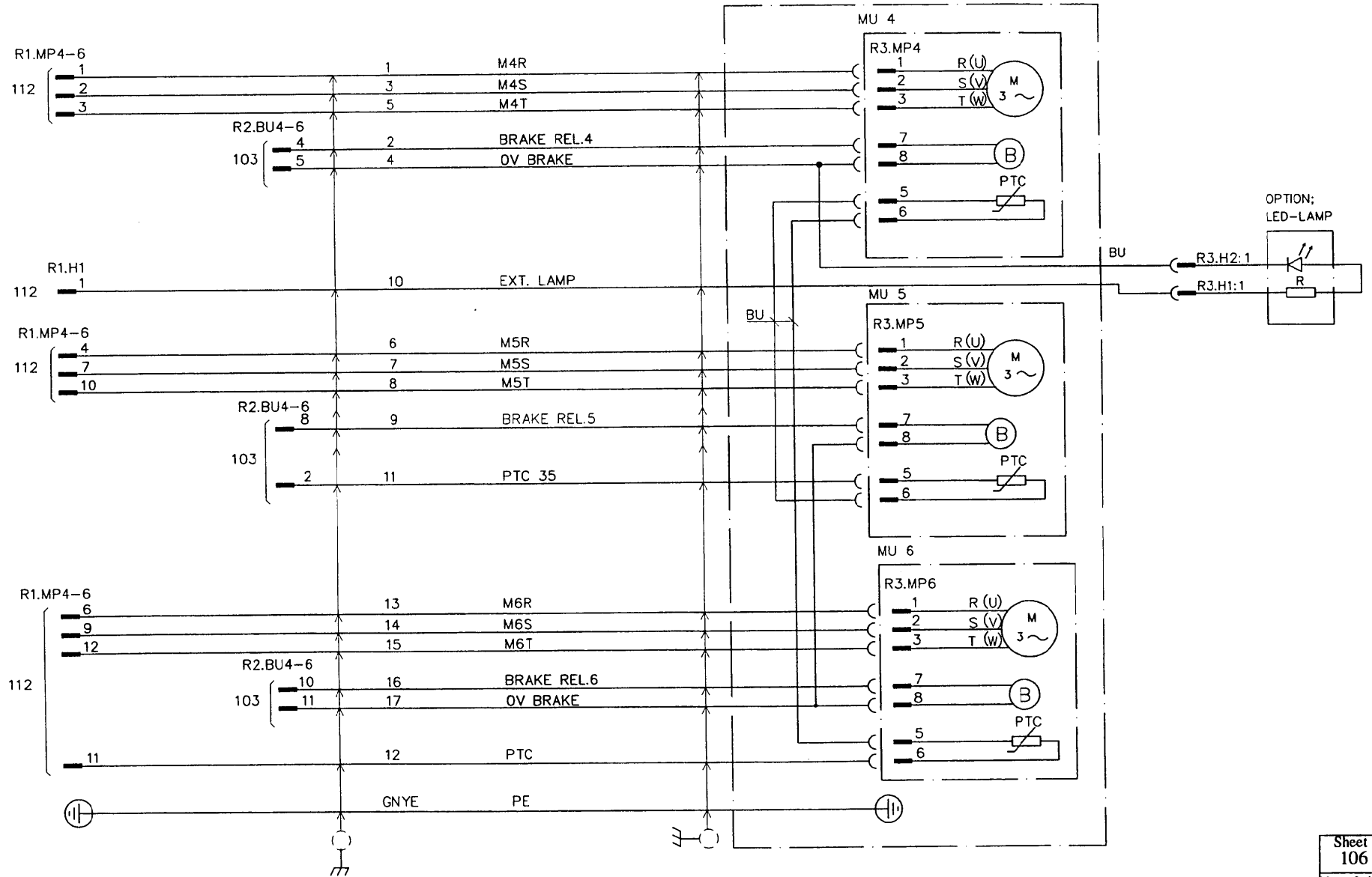

Motor axis 4-6, 1.5-10/16

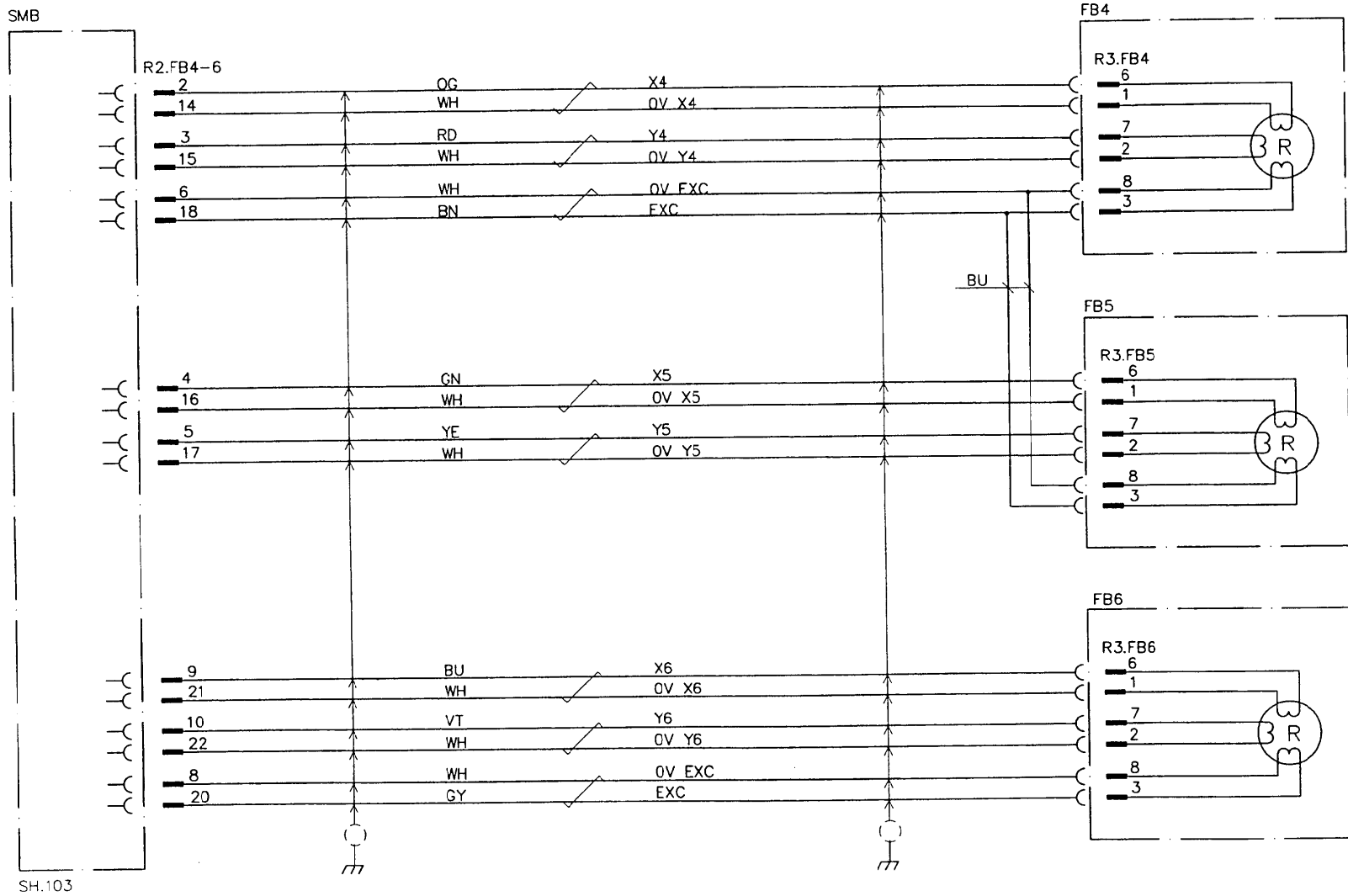

SH.103

Feed-back axis 4-6, 1.5-10/16

Sheet 107

No. of sh. 12

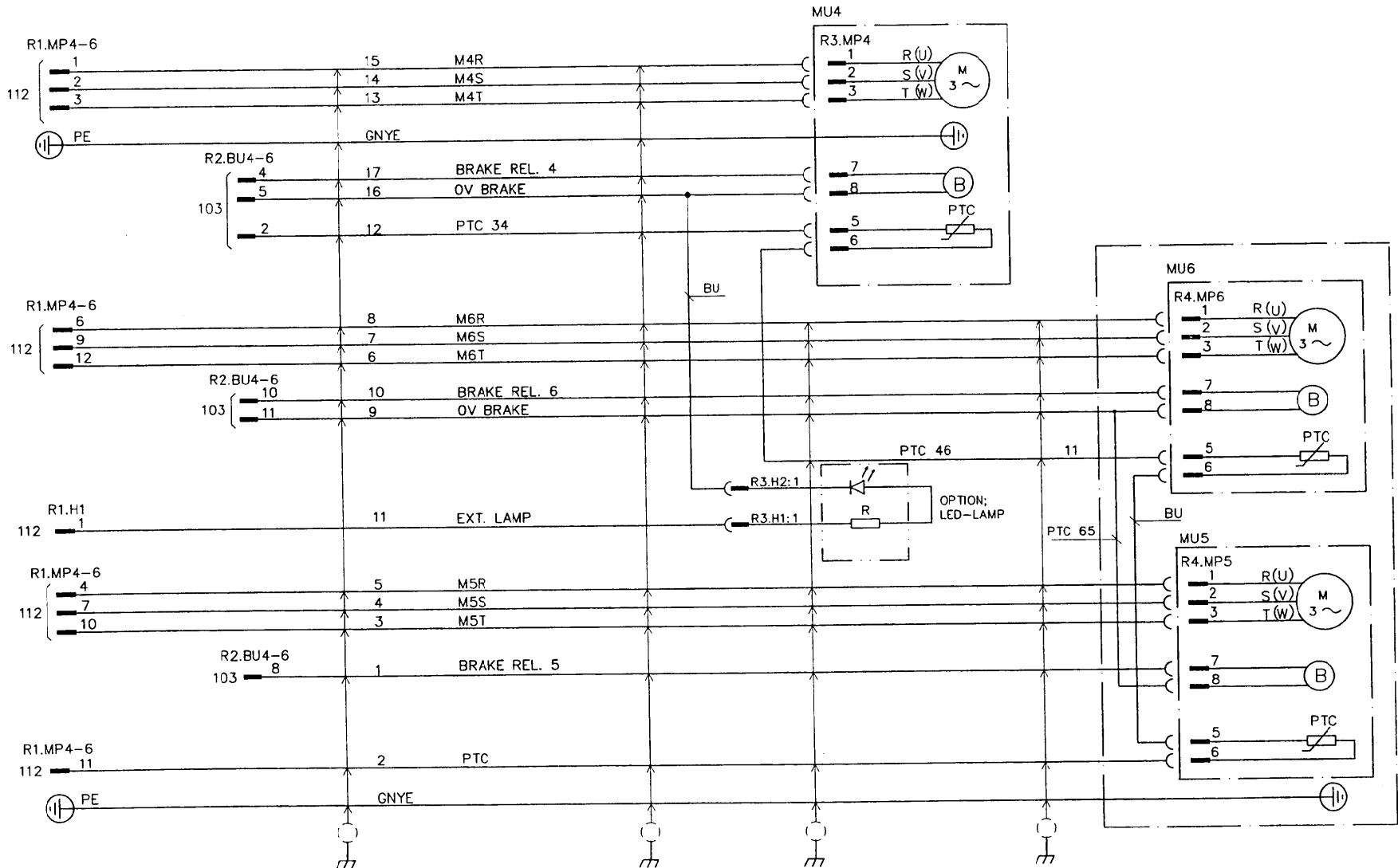

Motor axis 4-6, 1.8-5

SMB

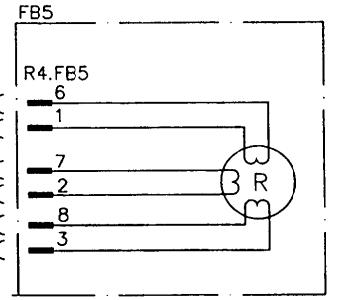
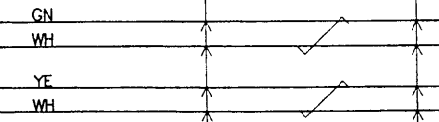
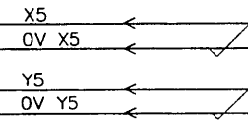
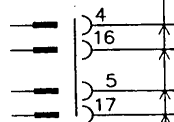
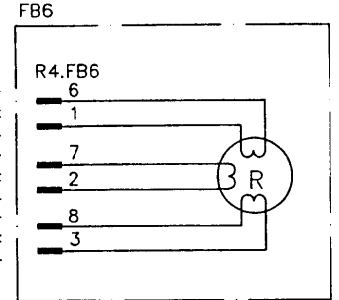
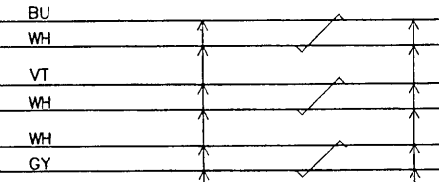
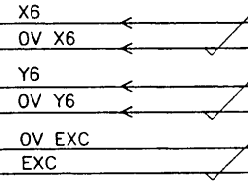
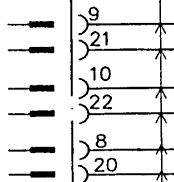
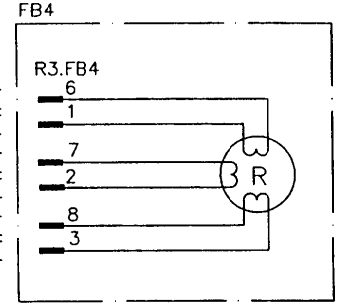
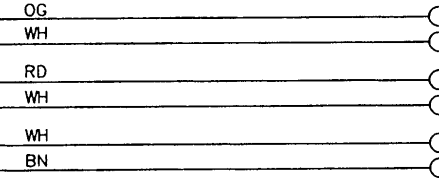
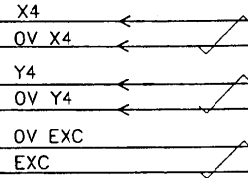
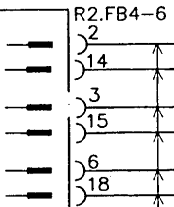

BU

SH.103



Feed-back axis 4-6, 1.8-5

Sheet 109
No. of sh. 12

112

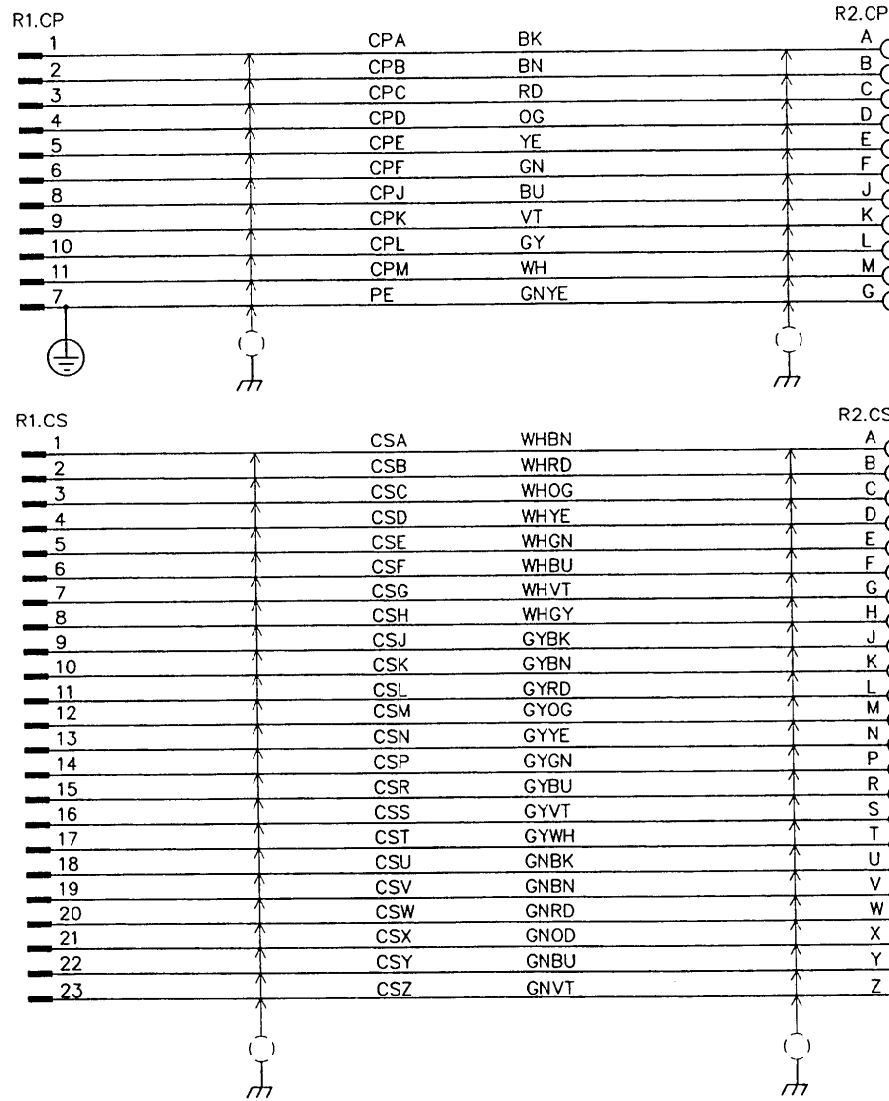

CUSTOMER CONNECTION
POWER
KUNDANSLUTNING
KRAFT

CUSTOMER CONNECTION
SIGNAL
KUNDANSLUTNING
SIGNAL

Customer connection

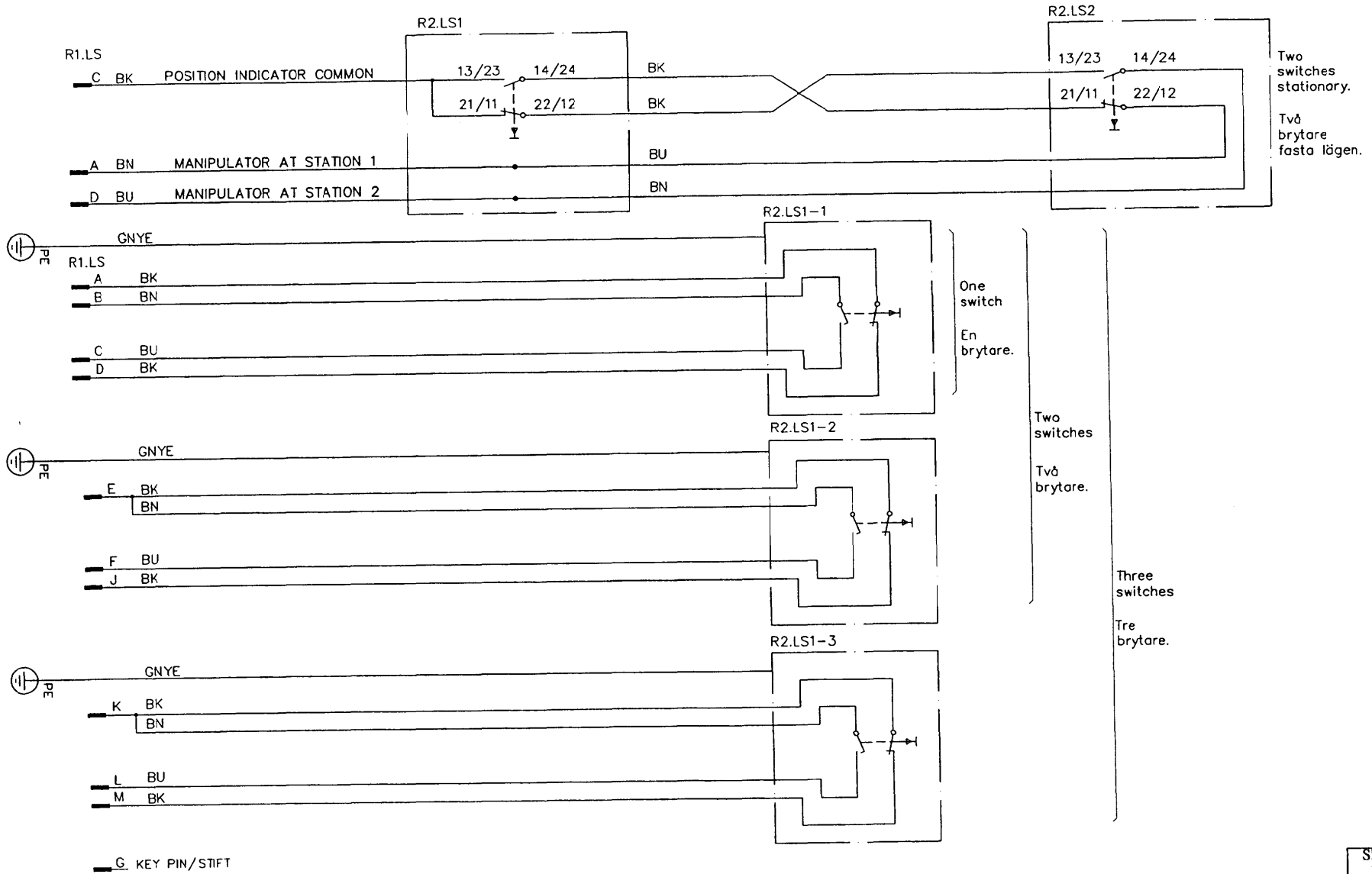

Pos. indicator axis 1, options

Sheet	111
No. of sh.	12

R1.MP			R1.MP 1-3
A1	M1R	BK	1
A2	M1S	BK	5
A3	M1T	BK	3
A4	M2R	BK	7
D1	M2S	BK	11
D2	M2T	BK	9
D3	M3R	BK	13
D4	M3S	BK	17
B1	M3T	BK	15
B4	EXT LIM 2	BU	16
B3	EXT LIM 1	BU	10
C2	LIM 2	BU	18
B2	OV PTC	BU	2
C1	LIM 1	BU	12

R1.MP 4-6			R1.MP 4-6
A10	M4R	BK	1
A9	M4S	BK	2
A8	M4T	BK	3
A7	M5R	BK	4
D10	M5S	BK	7
D9	M5T	BK	10
D8	M6R	BK	6
D7	M6S	BK	9
B10	M6T	BK	12
C9	BRAKE RELEASE	BU	8
C8	BRAKE RELEASE	BU	5
C10	OV BRAKE	BU	13
B9	PTC M	BU	11
B7	OV BRAKE	BU	14
B8	BRAKE PB	BU	15

R1.HI			R1.HI
C7	EXT. LAMP	BU	1

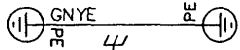

R1.SMB			R2.SMB
A	SDI	WH	9
B	SDI-N	BU	5
C	SDO	WH	8
D	SDO-N	OG	4
E	OV	WH	3
F	+24V	GN	7
K	+BATSUP	GY	6
L	OVBATLD	RD	2
J			
M	KEY PINNE/ NYCKLINGSPINNE		

104

106, 108

103

106, 108

103

110

103

R1.CP/CS			R1.CP
A1	CPA	OG	1
B1	CPB	OG	2
C1	CPC	OG	3
D1	CPD	OG	4
A2	CPE	OG	5
B2	CPF	OG	6
C2	CPJ	OG	8
D2	CPK	OG	9
A3	CPL	OG	10
B3	CPM	OG	11

R1.CS			R1.CS
B5	CSA	OG	1
C5	CSB	OG	2
D5	CSC	OG	3
A6	CSD	OG	4
B6	CSE	OG	5
C6	CSF	OG	6
D6	CSG	OG	7
A7	CSH	OG	8
B7	CSJ	OG	9
C7	CSK	OG	10
D7	CSL	OG	11
A8	CSM	OG	12
B8	CSN	OG	13
C8	CSP	OG	14
D8	CSR	OG	15
A9	CSS	OG	16
B9	CST	OG	17
C9	CSU	OG	18
D9	CSV	OG	19
A10	CSW	OG	20
B10	CSX	OG	21
C10	CSY	OG	22
D10	CSZ	OG	23

110

External connections, options

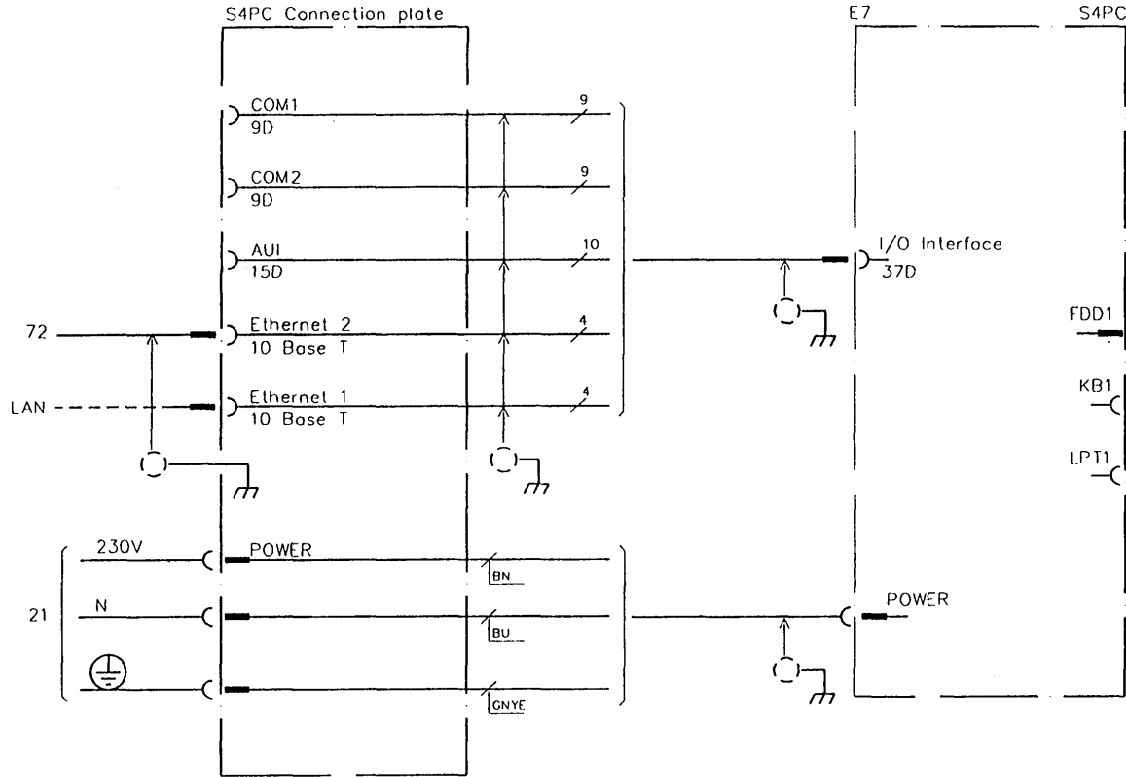

S4PC workstation

A

A

B

B

C

C

D

D

The contents of this document are the property of ABB Robotics Products AB. It is to be used only for the purposes intended by ABB Robotics Products AB. It is not to be distributed outside the organization.

The information in this document is subject to change without notice and should not be construed as a commitment by ABB Robotics Products AB. ABB Robotics Products AB assumes no responsibility for any errors that may appear in this document.

In no event shall ABB Robotics Products AB be liable for incidental or consequential damages arising from use of this document or of the software and hardware described in this document.

This document and parts thereof must not be reproduced or copied without ABB Robotics Products AB's written permission, and the contents thereof must not be imparted to a third party nor be used for any unauthorized purpose. Contravention will be prosecuted.

Additional copies of this document may be obtained from ABB Robotics Products AB at its then current charge.

CIRCUIT DIAGRAM

S4C M97

Cable 665, all the wire have changed color marking
Latest revision

Prepared by, date T Stålnacke, 980610	Responsible department SEROP/KCS	Title Circuit Diagram External Axes Cubicle Externt axelskåp	Sheet 0 No. of sh. 22
Approved by, date B Nilsson, 980611	Take over department		
Status APPROVED	Document No. 3HAC 1914-3		Rev. Ind. 01
ABB ABB Robotics Products			

A

A

SHEET	Opt.	CONTENTS
1		LIST OF CONTENTS
2		VIEW OF CONTROL CABINET
2.1		KEYING
3		DESIGNATION
4		BLOCK DIAGRAM
5		INTERFACE, BASIC AND EXTERNAL AXES CUBICLE
6	37x	MAINS CONNECTION
7	37x	TRANSFORMER UNIT
8		POWER AND I/O SUPPLY
9		POWER UNIT
10		BLEEDER AND FAN UNIT
11	431	SERVICE EQUIPMENT SUPPLY
12-14		INTERFACE DRIVE UNIT
15-17		DRIVE UNITS

B

B

The accuracy of data in this document and the design of the drawings are the responsibility of the drafter. The manufacturer is responsible for the accuracy of the data in this document and the design of the drawings.

C

C

D

D

LIST OF CONTENTS

Cable 665, all the wire have changed color marking
Latest revision

Prepared by, date T Stålnacke, 980610	Responsible department SEROP/KCS	Title Circuit Diagram 
Approved by, date B Nilsson, 980611	Take over department	
Status APPROVED	External Axes Cubicle Externt axelskåp	
Document No. ABB ABB Robotics Products		3HAC 1914-3
		Sheet 1 No. of sh. 22 Rev. Ind. 01

A

B

C

D

A

B

C

D

The names of objects in this diagram are used for the identification of the objects in the wiring diagrams. The objects in this diagram are not necessarily in the same position as in the actual cabinet.

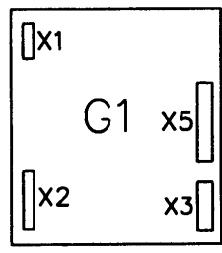
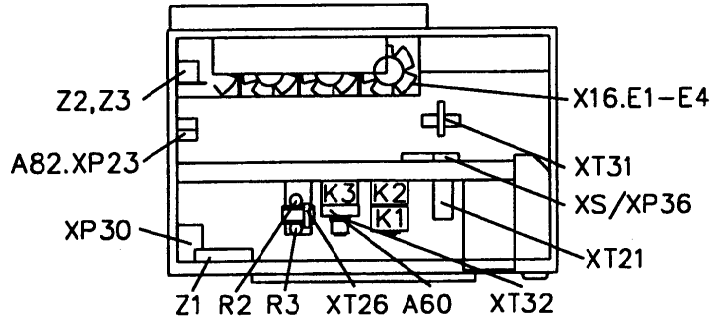
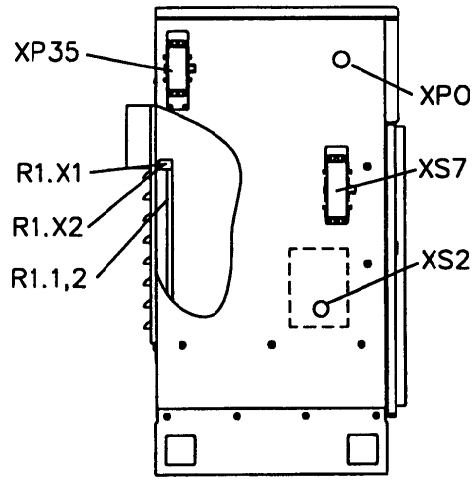
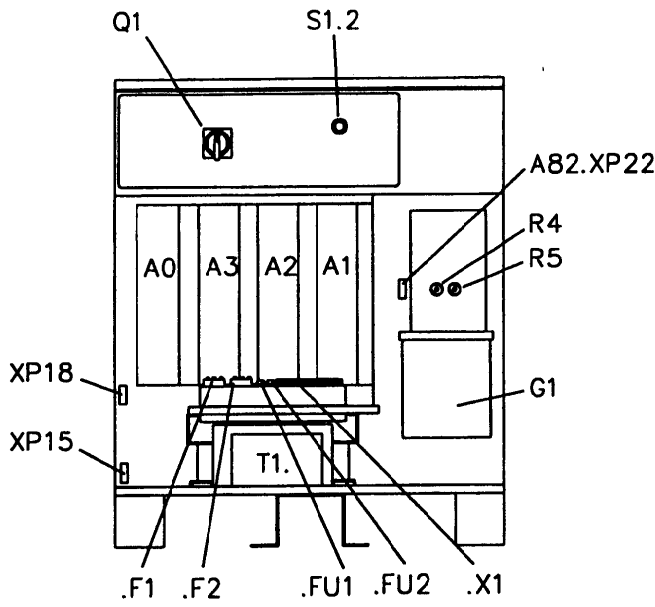

VIEW OF CONTROL CABINET

Cable 685, all the wire have changed color marking
 Latest revision

Prepared by, date T Stålnacke, 980610	Responsible department SEROP/KCS	Title External Axes Cubicle	Circuit Diagram
Approved by, date B Nilsson, 980611	Take over department	Externert axelskåp	
Status APPROVED		Document No. 3HAC 1914-3	Sheet 2 No. of sh. 22 Rev. Ind. 01
ABB Robotics Products			

A

A

Contact	KEYING POS.			
	A	B	C	D
XP/XS35			⊗	⊗
XS7	⊗		⊗	

B

B

We reserve all rights in this document and in the design contained herein. Reproduction or use in any form without the written permission of ABB Robotics Products AB is strictly prohibited.

C

C

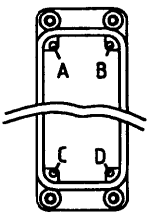

D

D

KEYING

Cable 665, all the wire have changed color marking
 Latest revision

Prepared by date T Stålnocke, 980610	Responsible department SEROP/KCS	Title Circuit Diagram	
Approved by date B Nilsson, 980611	Take over department		
Status APPROVED		External Axes Cubicle Externt axelskåp	Sheet 2.1 No. of sh. 22 Rev. Ind. 01
ABB ABB Robotics Products		Document No. 3HAC 1914-3	

A

A

SHEET DESIGNATION

4,15-17	A0	Rectifier Drive system
4,15-17	A1-A3	Drive unit
9	A60	Varistor unit
4,12-17	AB2.XP22	Drive system
4,12-14	AB2.XP23	Measurement system
4,8,12-14	G1	Power supply
4,9	K1,K2	Motor on contactor 1,2
4,9	K3	Brake contactor
4,6	Q1	Mains switch
10	R1.1-R1.2	Bleeder resistor
4,10	R1.X1,X2	Bleeder
9	R2, R3	Inrush current limiter resistors, DC-link
4,8	R4, R5	5V preload
4,9	S1	Control panel
9	S1.2	Motor on, LP
4,7	T1	Transformer, Mains
7	T1.F1-2	Automatic fuse
7	T1.FU1-2	Fuse
7	T1.X1	Temperature sensor, transformer
4,6	XP0	Mains Plug
4,10	XP15,16	Fans E1-E4
4,15-17	XP18	Brake extension
6	XP/XS30	Mains switch connection
4,5,8	XP31	Customer I/O supply
4,5,12-14	XP35	External axis control
4,9	XP36	Control panel extension
12-14	XS2	Outlet control cable
4,15-17	XS7	External axis power
4,11	XT/XS21	Service outlet connection
4,6	XT26	Direct supply connection
4,8	XT32	Brake extension
4,6	Z1	Mains filter
4,15-17	Z2,Z3	Filter limit switch

B

B

The content of this document and the data therein are confidential. Reproduction, use or disclosure in any form without the written permission of ABB is strictly prohibited.

C



C

D

D

DESIGNATION

Cable 665, all the wire have changed color marking
 Latest revision

Prepared by, date T Stölnacke, 980610	Responsible department SEROP/KCS	Title Circuit Diagram	
Approved by, date B Nilsson, 980611	Title over department		
Status APPROVED	External Axes Cubicle Extern axelsköp		Sheet 3 No. of sh. 22
 ABB Robotics Products		Document No. 3HAC 1914-3	Rev. Ind. 01

A

A

B

B

C

C

D

D

All reserved and rights in this document used in the ABB Robotics Products are reserved. No part of this document may be reproduced, stored in a retrieval system, or transmitted in any form or by any means, electronic, mechanical, photocopying, recording, or by any information storage and retrieval system, without the prior written permission of ABB Robotics Products AB.

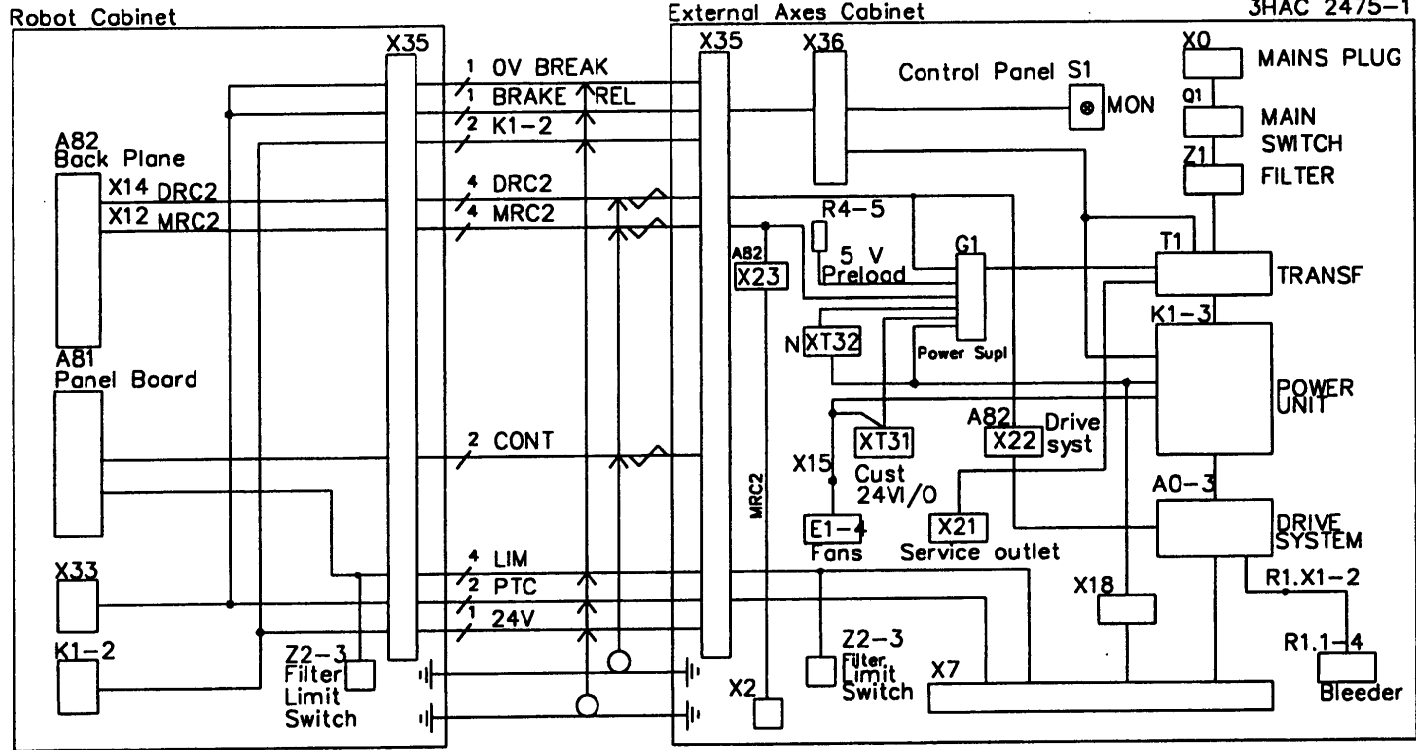

BLOCK DIAGRAM

Cable 665, all the wire have changed color marking
Latest revision

Prepared by, date
T Stålnacke, 980610

Responsible department
SEROP/KCS

Title
Circuit Diagram

Approved by, date
B Nilsson, 980611

Take over department

External Axes Cubicle
Externi axelskåp



Sheet
4

Status
APPROVED

Document No.
3HAC 1914-3

No. of sh.
22

ABB ABB Robotics Products

Rev. Ind.
01

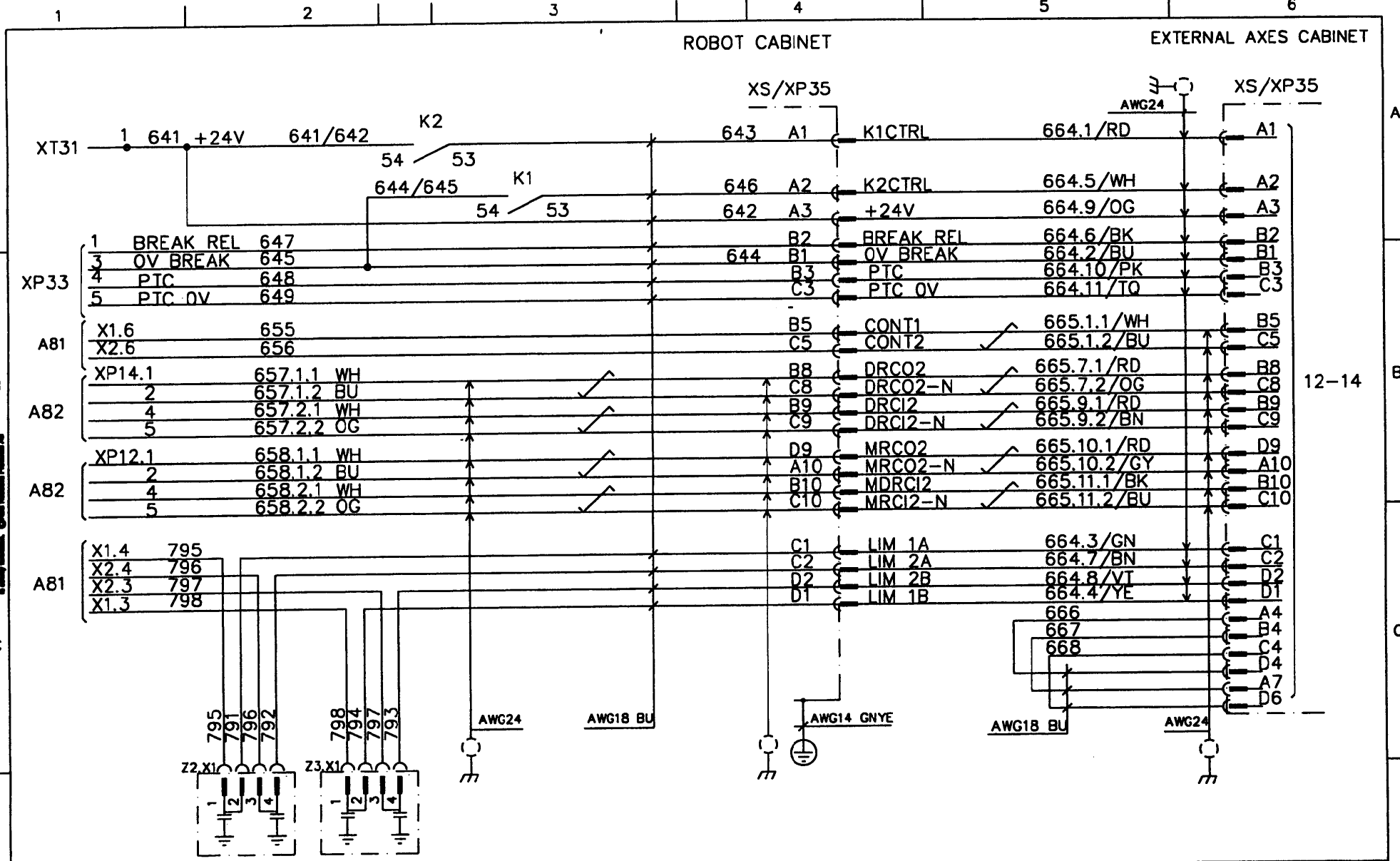

The number of digits in cable identification code is the same as the number of digits in the terminal block identification code. The number of digits in the terminal block identification code is the same as the number of digits in the terminal block identification code.

INTERFACE, ROBOT CABINET
AND EXTERNAL AXES CABINET

Cable 665, all the wire have changed color marking
Latest revision

Prepared by, date T Stålnocke, 980610	Responsible department SEROP/KCS	Title External Axes Cubicle Externi axelskåp	Circuit Diagram
Approved by, date B Nilsson, 980611	Take over department		
Status APPROVED		Document No. 3HAC 1914-3	Sheet 5 No. of sh. 22 Rev. Ind. 01



The number of digits in this document must be the same as the number of digits in the corresponding drawing. If the number of digits in this drawing is different from the number of digits in the corresponding drawing, the drawing is the correct one.

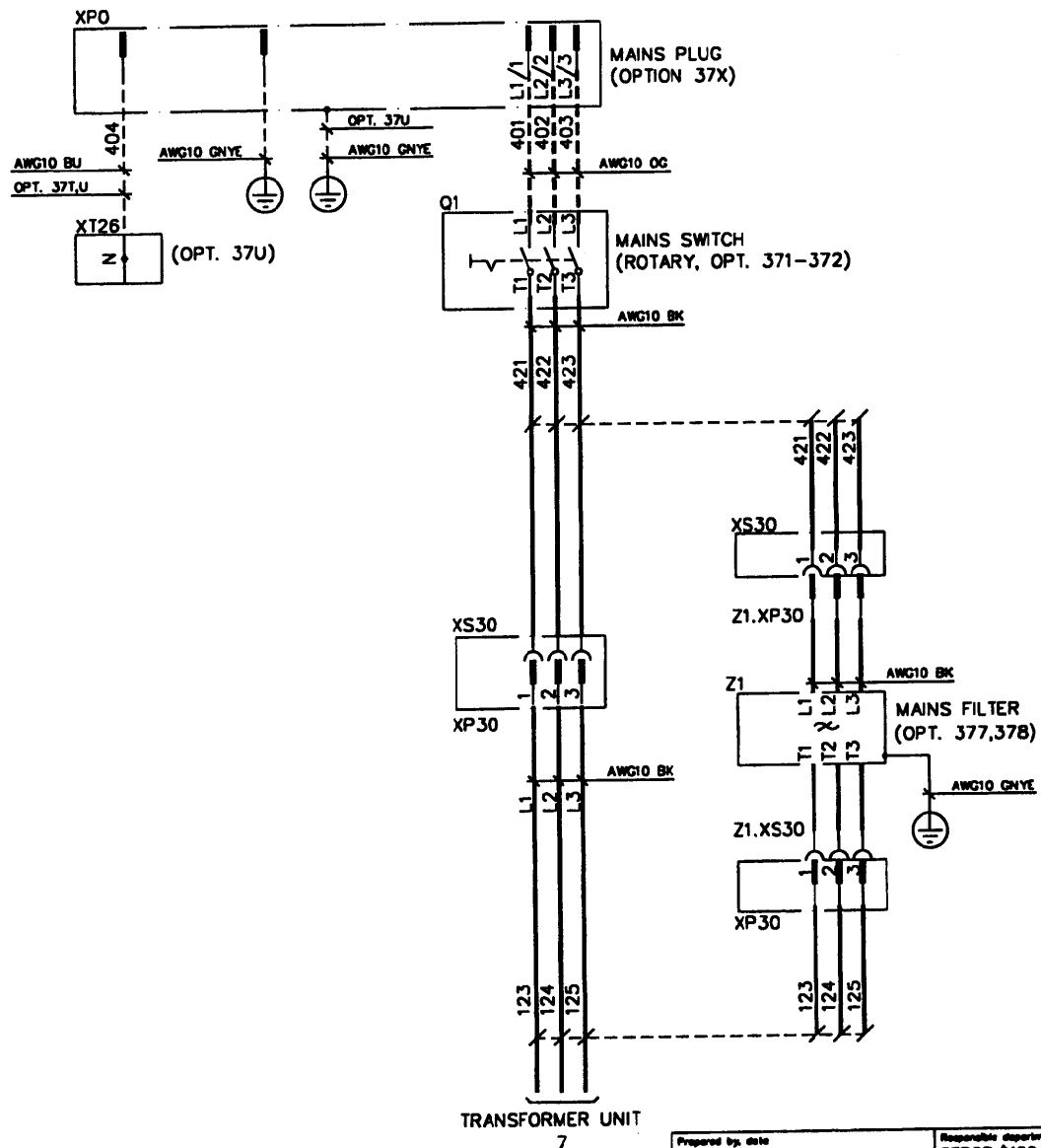

Prepared by, date T Stålnöcke, 980610	Responsible department SEROP/KCS	Title Circuit Diagram							
Approved by, date B Nilsson, 980611	Take over department	External Axes Cubicle							
Status APPROVED		Externät axelskåp	<table border="1"> <tr><td>Sheet</td><td>6</td></tr> <tr><td>No. of sh.</td><td>22</td></tr> <tr><td>Rev. Ind.</td><td>01</td></tr> </table>	Sheet	6	No. of sh.	22	Rev. Ind.	01
Sheet	6								
No. of sh.	22								
Rev. Ind.	01								
ABB ABB Robotics Products		Document No. 3HAC 1914-3							

Mains connection

Cable 665, all the wire have changed color marking
Latest revision

A

A

B

B

C

C

D

D

T1 MAINS VOLTAGE			JUMPERS T1.X1
3HAC 0751-1	3HAC 0752-1	3HAC 0753-1	IN1-E, IN2-E, IN3-E
200V	400V	475V	IN1-F, IN2-F, IN3-F
220V	440V	500V	IN1-G, IN2-G, IN3-G
400V	475V	600V	IN1-H, IN2-H, IN3-H

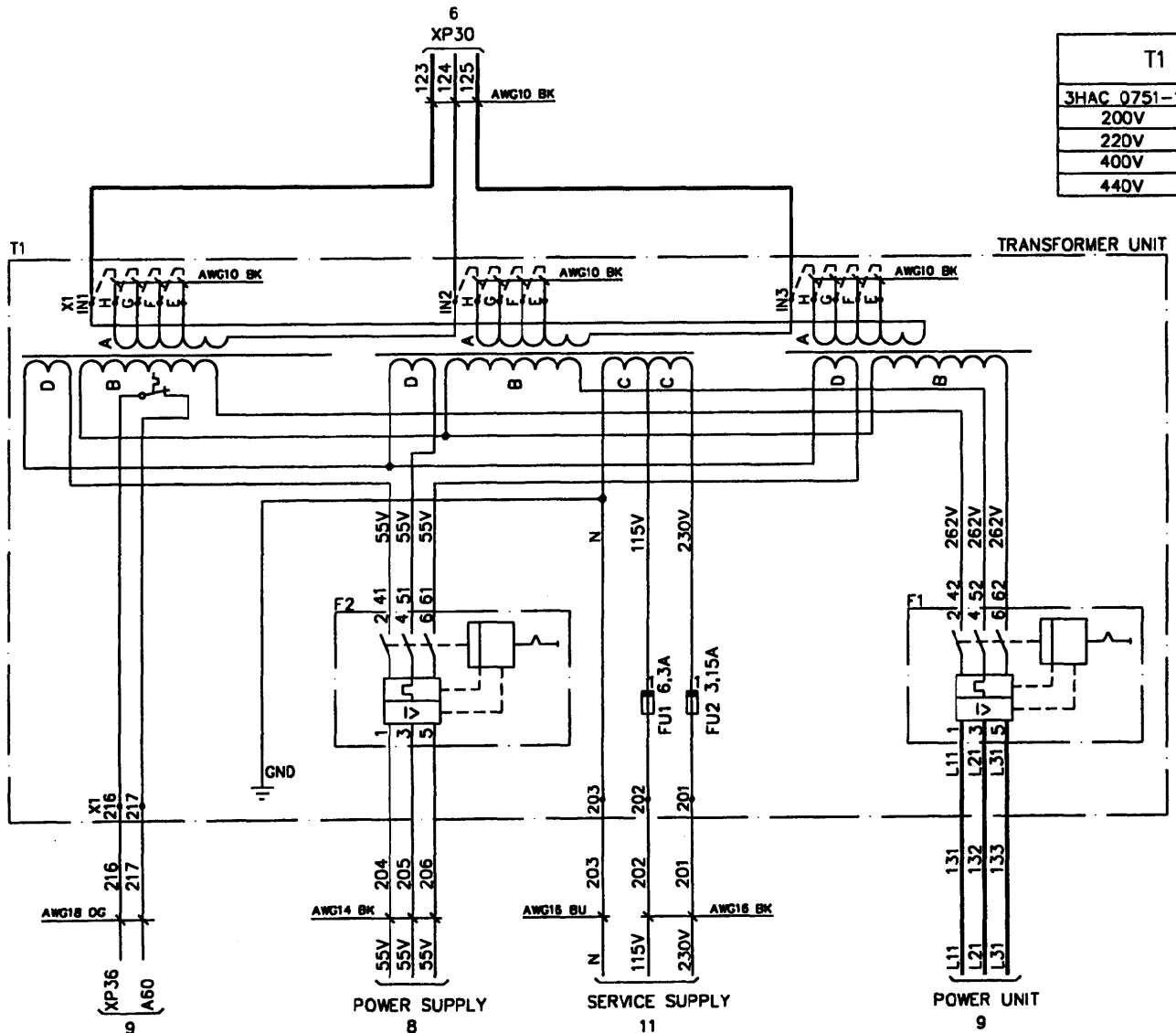

TRANSFORMER UNIT (OPT. 37x)

The names of items in this document and the drawings are trademarks of ABB Robotics Products AB. All other names are trademarks of their respective owners.

Transformer unit

Cable 665, all the wire have changed color marking
Latest revision

Prepared by, date
T Stålnacke, 980610

Approved by, date
B Nilsson, 980611

Status
APPROVED

Responsible department
SEROP/KCS

Take over department

Title
External Axes Cubicle
Externt axelskåp

Circuit Diagram

Sheet 7

No. of sh. 22

Document No.
3HAC 1914-3

Rev. Ind.
01



A

B

C

D

A

B

C

D

7
TRANSFORMER UNIT

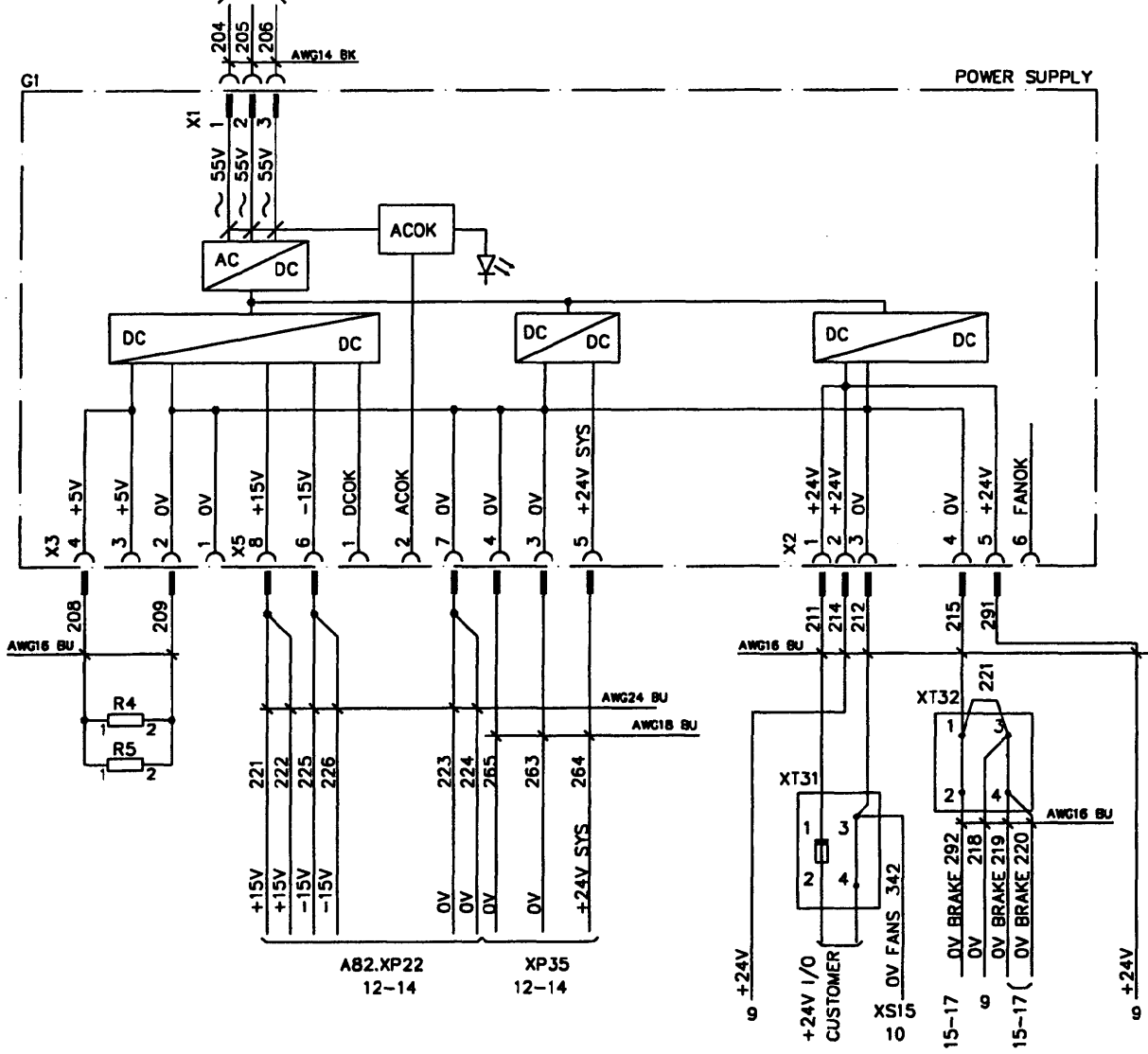

The information on this drawing is the property of ABB Robotics Products AB. It is intended for use only in connection with the equipment specified on the drawing. It is not to be used for any other purpose without the written consent of ABB Robotics Products AB.

Power supply
I/O supply

Cable 665, all the wire have changed color marking
Latest revision

Prepared by, date T Stålnacke, 980610	Responsible department SEROP/KCS
Approved by, date B Nilsson, 980611	Take over department
Status APPROVED	

Title Circuit Diagram	
Extens Axes Cubicle Externt axelskåp	
Document No. 3HAC 1914-3	

Sheet 8
No. of sh. 22
Rev. Ind. 01

ABB ABB Robotics Products

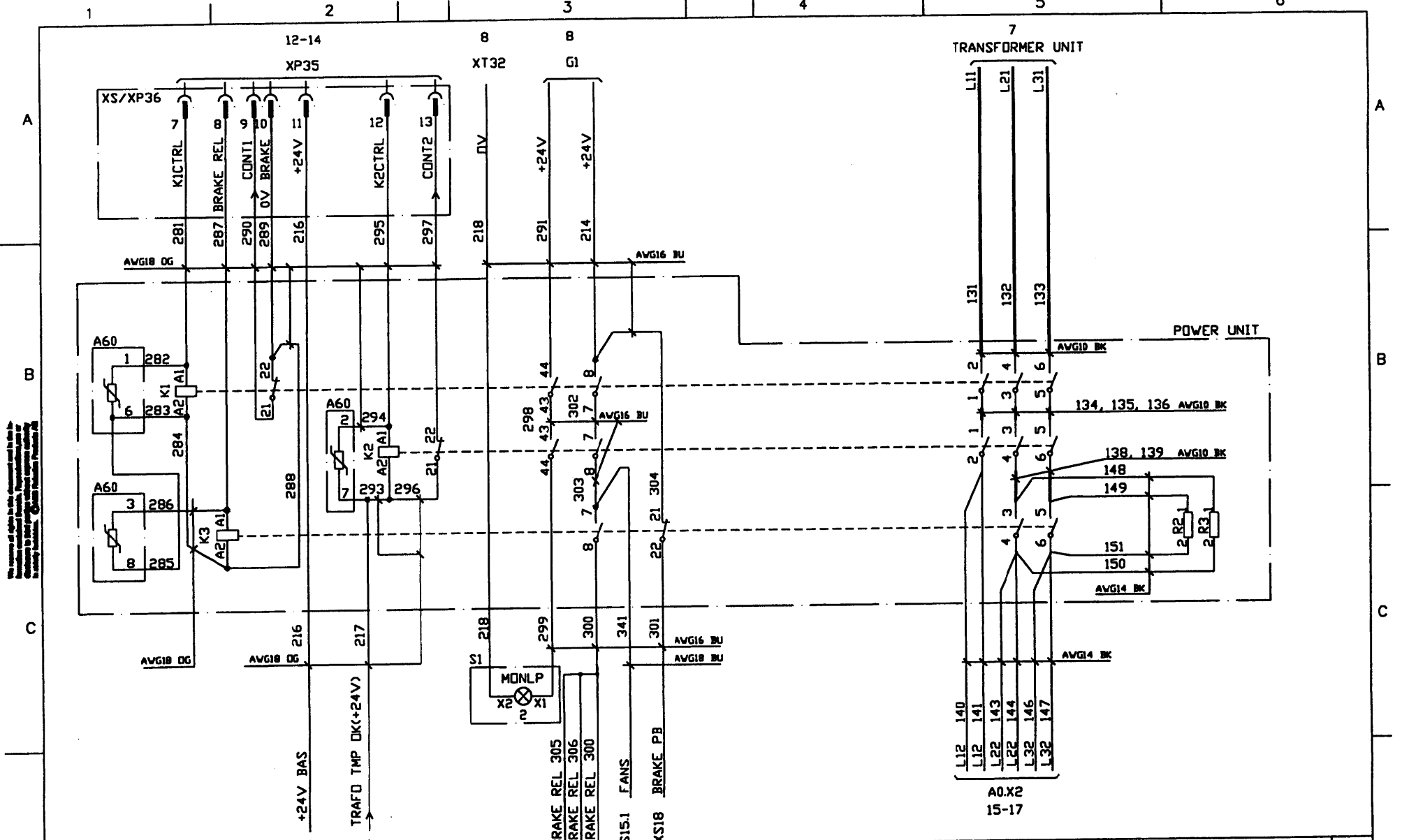

The use of all rights in this document is reserved for the
 manufacturer. No part of this document may be reproduced
 or transmitted in any form or by any means, electronic
 or mechanical, including photocopying, recording, or
 by any information storage and retrieval system, without
 the prior written permission of the manufacturer.

Power unit

Cable 665, all the wire have changed color marking
 Latest revision

Prepared by: date T Stånacke, 980610	Responsible department SEROP/KCS	This
Approved by: date B Nilsson, 980611	Take over department	External Axes Cubicle Externt oxelskåp
Status APPROVED		Document No.

Circuit Diagram	
Sheet	9
No. of sh.	22
Rev. Int.	01

ABB ABB Robotics Products

3HAC 1914-3

A

B

C

D

A

B

C

D

The nature of this document and its use is limited to the specific application and system in which it is used. It is not intended to be a substitute for the manufacturer's instructions. ©ABB Robotics Products AB

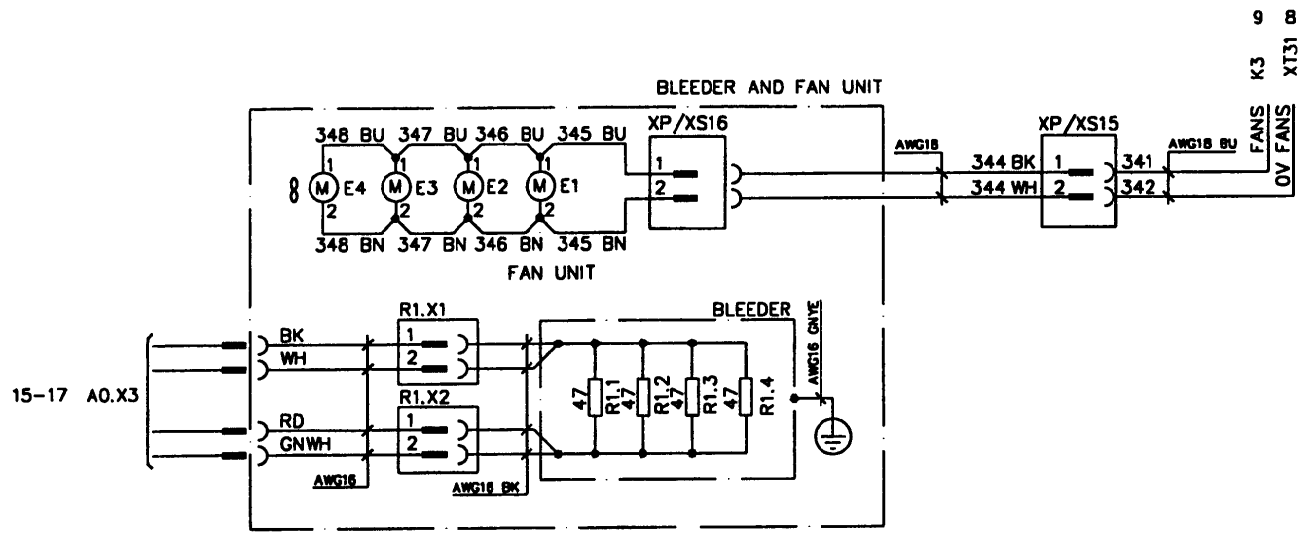

Prepared by, date T Stålnacke, 980610	Responsible department SEROP/KCS	Title External Axes Cubicle Externt axelskåp	Circuit Diagram
Approved by, date B Nilsson, 980611	Take over department		
Status APPROVED		Document No. 3HAC 1914-3	Sheet 10
Cable 665, all the wire have changed color marking Latest revision		Rev. No. 01	No. of sh. 22



1 2 3 4 5 6

A

A

B

B

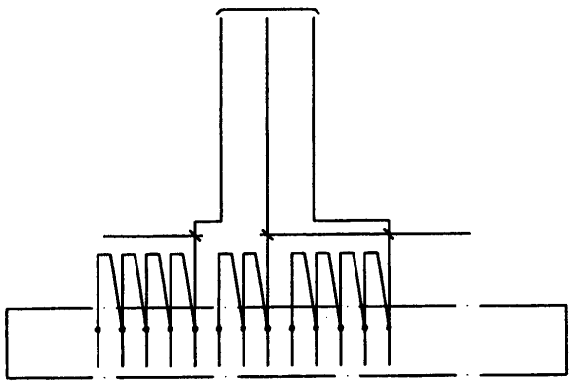

The reserves of rights in this document used in the ABB Robotics Products are the property of ABB Robotics Products AB. Reproduction, use or distribution of this document is prohibited without the written permission of ABB Robotics Products AB.

C



C

D

D

SERVICE EQUIPMENT SUPPLY

Cable 665, all the wires have changed color marking

Prepared by, date T Ståinocke, 980610	Responsible department SEROP/KCS	Title External Axes Cubicle Externt axelskåp	 Circuit Diagram Sheet 11 No. of sh. 22 Rev. Ind. 01
Approved by, date B Nilsson, 980611	Take over department		
Status APPROVED	Document No. 3HAC 1914-3		
 ABB Robotics Products			

The numbers of signals in this diagram are used to identify the signals in the wiring harness. The numbers are not necessarily the same as the numbers in the wiring harness.

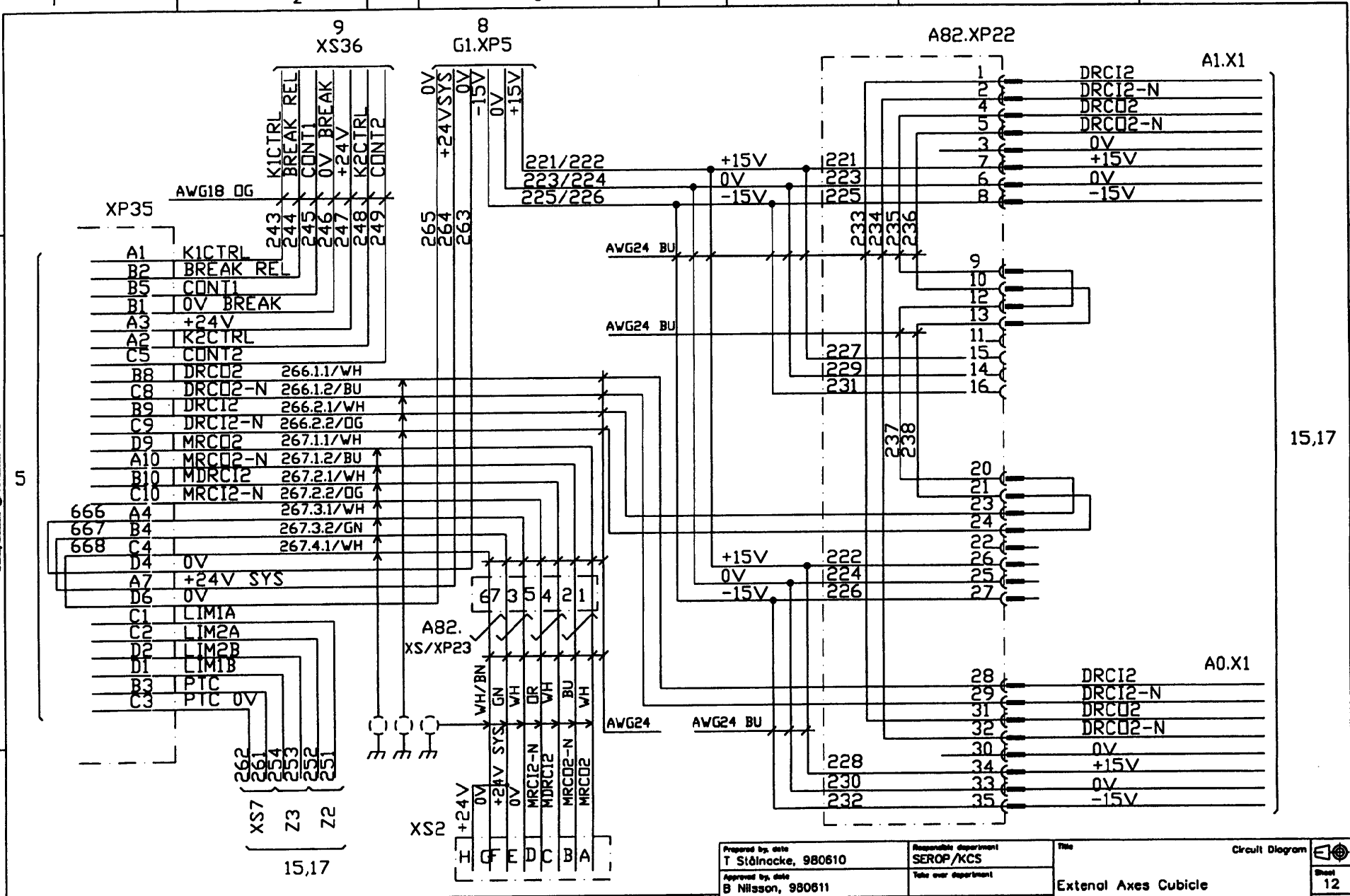

INTERFACE 1 EXTERNAL DRIVE UNIT

Cable 685, all the wires have changed color marking
Latest revision

Prepared by, date
T Stålnocke, 980610

Approved by, date
B Nilsson, 980611

Status
APPROVED

Responsible department
SEROP/KCS

Title
Extens Axes Cubicle
Externt oxelskåp

ABB ABB Robotics Products

Document No.
3HAC 1914-3

Circuit Diagram

Sheet
12

No. of sh.
22

Rev. Ind.
01

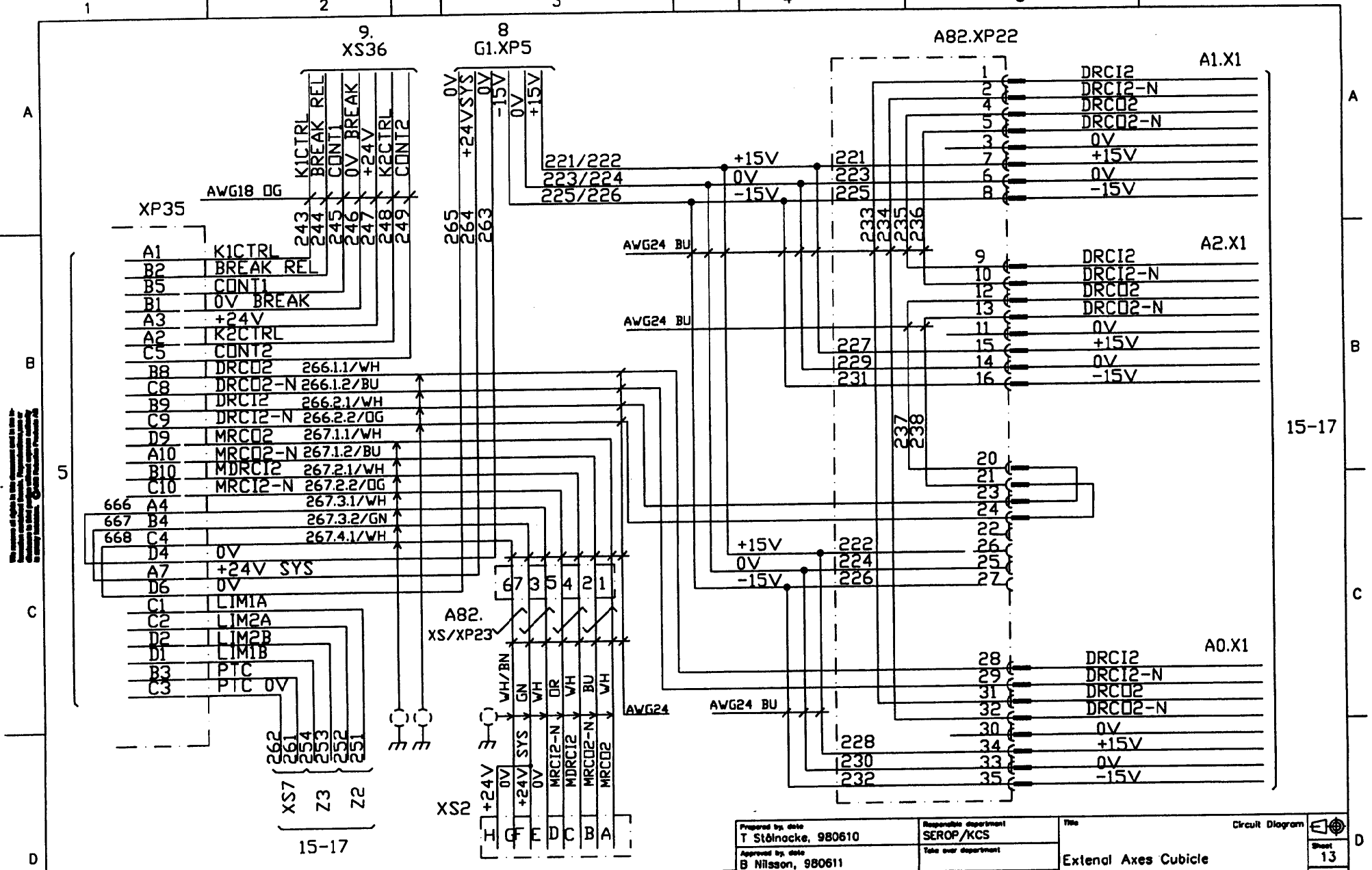

The information on this drawing is the property of ABB Robotics Products. It is intended for use only in the context of the project for which it was prepared. It is not to be used for any other purpose without the written consent of ABB Robotics Products.

INTERFACE 2 EXTERNAL DRIVE UNITS

Cable 665, all the wire have changed color marking
 Latest revision

Prepared by, date T Stölnacke, 980610	Responsible department SEROP/KCS	Title External Axes Cubicle Externt axelskåp	Circuit Diagram
Approved by, date B Nilsson, 980611	Take over department		Sheet 13
Status APPROVED		Document No. 3HAC 1914-3	No. of sh. 22
ABB ABB Robotics Products			Rev. Ind. 01

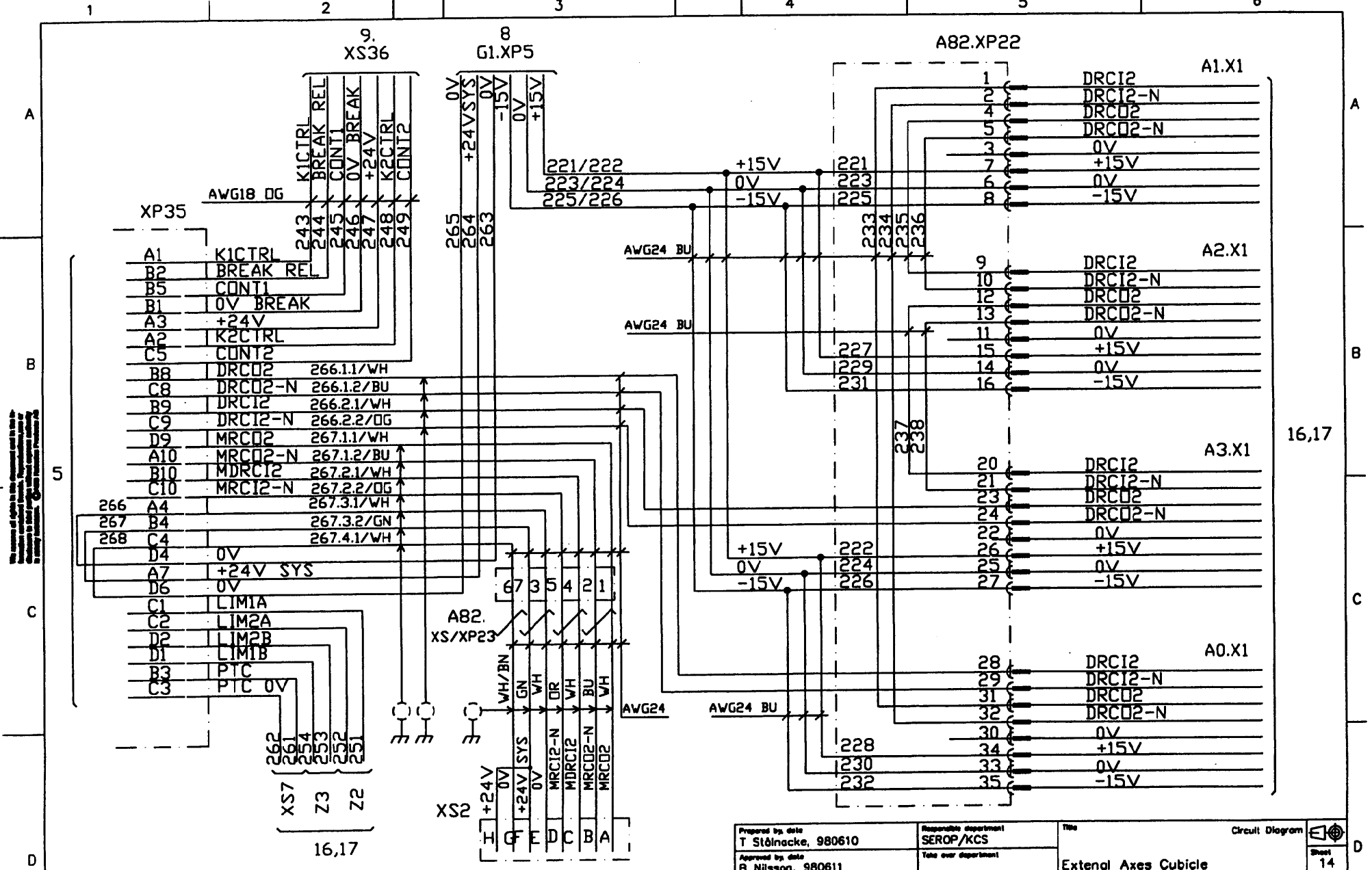

All wires are color coded in this diagram and must be used as such. If a different color is used, it must be marked with the correct color code. The color code is given in the legend. The color code is given in the legend. The color code is given in the legend.

INTERFACE 3 EXTERNAL DRIVE UNITS

Cable 665, all the wire have changed color marking
Latest revision

Prepared by date T Stålnacke, 980610	Responsible department SEROP/KCS	Title External Axes Cubicle	Circuit Diagram
Approved by date B Nilsson, 980611	Take over department	Externert axelskåp	Sheet 14
Status APPROVED		Document no. 3HAC 1914-3	No. of sh. 22
ABB ABB Robotics Products			Rev. list 01

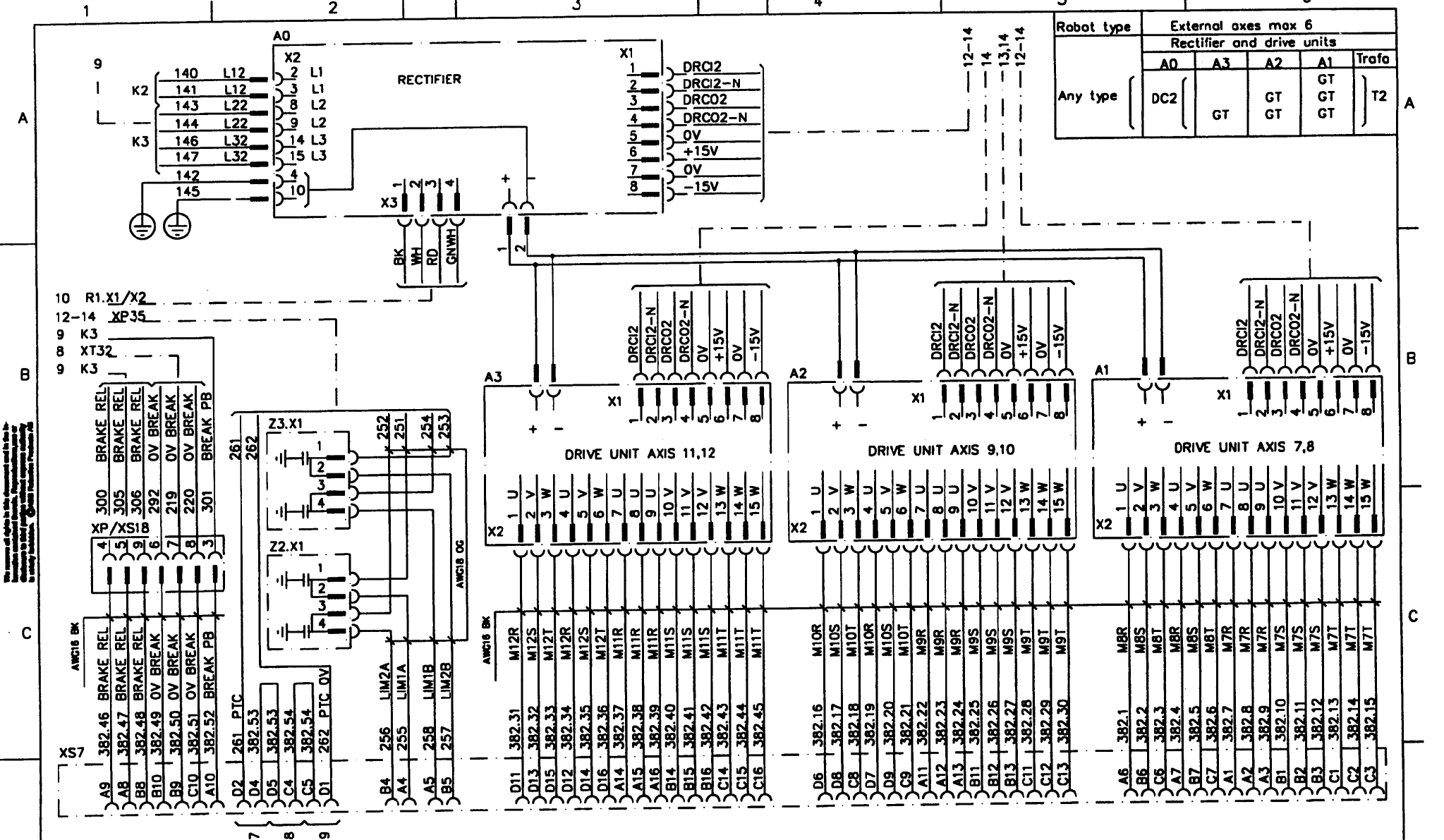

Robot type	External axes max 6				
	Rectifier and drive units				
	A0	A3	A2	A1	Trafo
Any type	DC2	GT	GT	GT	T2
			GT	GT	

The number of digits in the component and in the cable number is indicated in the legend. The number of digits in the cable number is indicated in the legend.

DRIVE UNIT GT

Cable 665, all the wire have changed color marking
Latest revision

Prepared by, date T Stålnöcke, 980610	Responsible department SEROP/KCS
Approved by, date B Nilsson, 980611	Talk over department
Status APPROVED	

This	Circuit Diagram
External Axes Cubicle	Sheet 15
Externert axelsköp	No. of ph. 22
Document No. 3HAC 1914-3	Rev. No. 01

ABB ABB Robotics Products

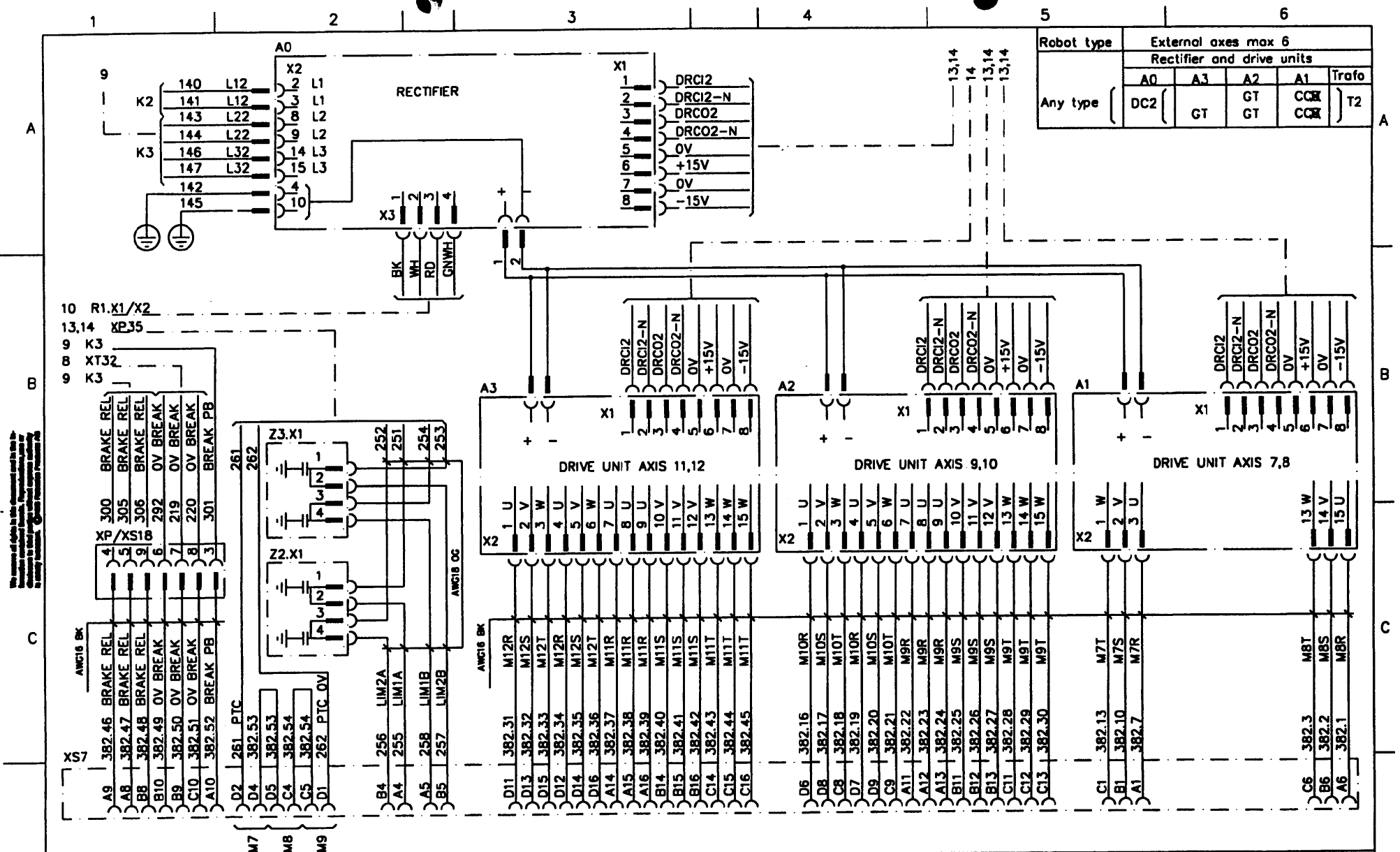

Robot type	External axes max 6				
	Rectifier and drive units				
	A0	A3	A2	A1	Trafa
Any type	DC2	GT	GT	CC/	T2
				CC/	

The names and design of the components used in this diagram are not intended to be a recommendation for any particular manufacturer. The manufacturer of any component used in this diagram should be contacted for the latest revision of the component's specifications.

DRIVE UNIT CC/ + GT

Cable 665, all the wire have changed color marking
 Latest revision

Prepared by, date T Stålnacke, 980610	Responsible department SEROP/KCS	Title External Axes Cubicle Externt axelskåp	Circuit Diagram
Approved by, date B Nilsson, 980611	Take over department		
Status APPROVED		Document No. 3HAC 1914-3	Sheet No. 16 No. of sh. 22 Rev. No. 01



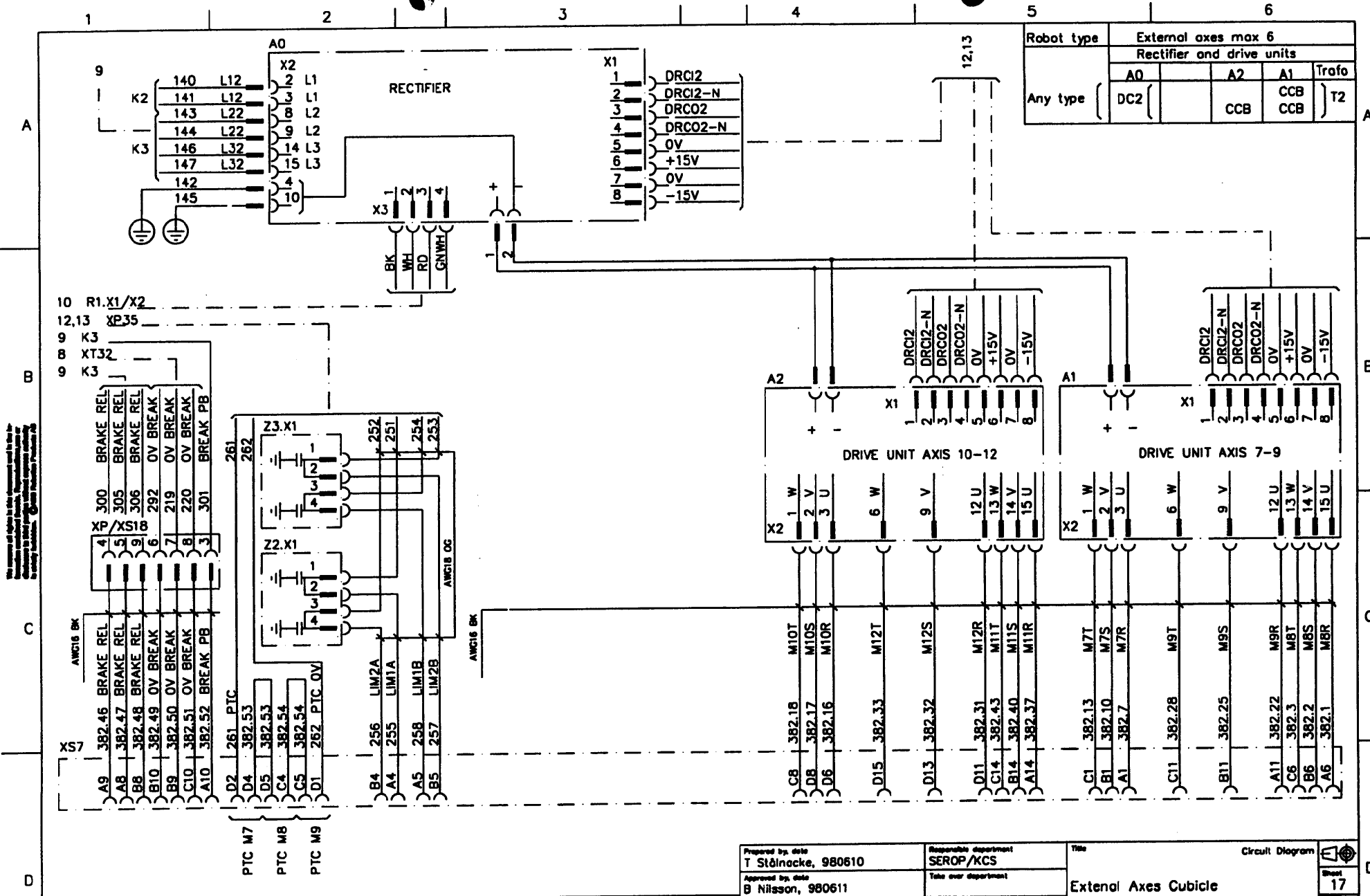

Robot type	External axes max 6			
	Rectifier and drive units			
	A0	A2	A1	Trofo
Any type	DC (CCB	CCB	T2

The numbers of digits in this diagram used in the
 drawings of the robot are the same as in the
 drawings of the robot. The numbers of digits
 in this diagram are the same as in the
 drawings of the robot.

DRIVE UNIT CCB

Cable 665, all the wire have changed color marking
 Latest revision

Prepared by date T Stålnacke, 980610	Responsible department SEROP/KCS	Title External Axes Cubicle Externi axelsköp	Circuit Diagram
Approved by date B Nilsson, 980611	Take over department	Document No. 3HAC 1914-3	Sheet 17 No. of sh. 22 Rev. Ind. 01
Status APPROVED	ABB Robotics Products		