

ELECTRICAL TROUBLESHOOTING MANUAL

FOR

IRB6400 INDUSTRIAL ROBOT & S4 CONTROL SYSTEM

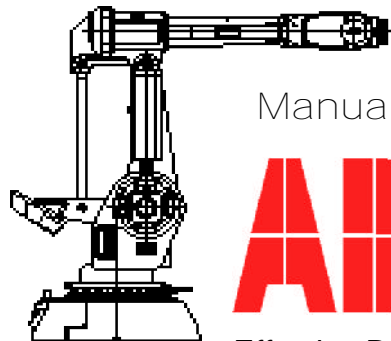

Manual Part #7000722



Flexible Automation Inc.
1250 Brown Road
Auburn Hills, Mich. 48326
(810) 391-9000

Effective Date: December 1, 1995

CAUTION



Do not perform any work covered in this manual until you have read it through completely and understand each step in the procedure. Be sure electrical main disconnect is locked out before starting any work on this system.

NOTE

The information in this document is subject to change without notice and should not be construed as a commitment by ABB Flexible Automation Inc. ABB assumes no responsibility for any errors that may appear in this document.

In no event shall ABB Flexible Automation Inc. be liable for incidental or consequential damages arising from the use of this document of the software and hardware described in this document.

The material in this document and must not be reproduced or copied in whole or in part without the written permission of ABB Flexible Automation Inc. The contents of this document must not be imparted to a third party nor be used for any unauthorized purpose. Contravention will be prosecuted.

Additional copies of this document may be obtained from ABB Flexible Automation at its then current charge.

© ABB Flexible Automation Inc.

Part Number: 7000722

ABB Flexible Automation Inc.
Auburn Hills, Michigan USA

TABLE OF CONTENTS

TABLE OF CONTENTS	TOC - I
INTRODUCTION	i
IDENTIFICATION	ii
MAINTENANCE	iii
TOOLS	iv
THIS MANUAL	v
CHAPTER DESCRIPTIONS	vi
APPENDICES DESCRIPTIONS	vii
SIGNS AND SYMBOLS	viii
1. Safety.....	1-3
1.1 General Safety	1-4
1.2 Safety Features	1-5
1.3 Safety Guidelines	1-6
1.4 Safety During Maintenance	1-8
1.5 Safety During Programming	1-8
1.6 Safety Control Chain of Operation	1-9
1.7 Risks Associated with Live Parts	1-11
1.8 Limitation of Liability	1-12
1.9 Related Information	1-12
2. Computer System	2-3
2.1 Overview	2-3
<i>Diagram 2-1 Computer System and System Boards ...</i>	<i>2-3</i>
2.2 System Description	2-4
<i>Diagram 2-2 Block Diagram</i>	<i>2-5</i>
2.3 Troubleshooting	2-6
2.3.1 General.....	2-6
2.3.2 Diagnostics	2-8
2.4 Board Descriptions	2-10
2.4.1 Robot Computer DSQC 326.....	2-11
2.4.2 Main Computer DSQC 316.....	2-12
2.4.3 Memory Board DSQC 317/6 Mb (DSQC 321/4Mb).....	2-13
2.4.4 Power Supply Unit DSQC 258.....	2-14
2.4.5 System Board DSQC 256A.....	2-15
2.4.6 Digital I/O Board DSQC 223.....	2-17
2.4.7 Combined I/O Board DSQC 315.....	2-18
2.4.8 Analog I/O Board DSQC 209.....	2-19
2.4.9 Remote I/O Board DSQC 239.....	2-20
2.4.10 Axis Board DSQC 233.....	2-21
2.5 Serial Measurement Board (SMB)	2-22
2.6 Teach Pendant	2-23
2.7 Component Cross Reference	2-24
2.8 List of Circuit Diagrams	2-25
2.9 Component Location Figures	2-47

Table of Contents (Cont)

Figure 2-1 Control Cabinet	2-47
Figure 2-2 Connectors	2-49
Figure 2-3 SMB	2-51
Figure 2-4 Back Plane AP80	2-53
Figure 2-5 Teach Pendant.....	2-55

3. Loading System Software.....3-3

3.1 Overview	3-3
3.2 Floppy Disk	3-4
3.3 Software Loading Procedure	3-5
3.4 Parameter Loading Procedure	3-8
3.5 Resolver Revolution Counter Update	3-9
3.6 List of Circuit Diagrams	3-13
3.7 Component Location Figures	3-17

Figure 3-1 Batteries	3-17
Figure 3-2 Floppy Disk Drive.....	3-19
Figure 3-3 Robot Calibration Position.....	3-21

4. Power ON4-3

4.1 Overview	4-3
4.2 AC Power Distribution	4-4
4.3 DC Power Distribution	4-5
4.4 Component Cross Reference	4-8
4.5 List of Circuit Diagrams	4-9
4.6 Component Location Figures	4-23

Figure 4-1 Inside Front of Control Cabinet.....	4-23
Figure 4-2 Inside Swing Gate.....	4-25
Figure 4-3 Brake Push Buttons	4-27
Figure 4-4 Customer Connection XS3/XT3.....	4-29
Figure 4-5 Operator's Panel	4-31

5. Motor ON/Dual Run Chain.....5-3

5.1 Overview	5-3
---------------------------	------------

Diagram 5-1 Computer System and System Board..... 5-4

5.2 Manual (Reduced or Full) Speed Mode Circuit .	5-5
--	------------

5.2.1 Run Chain 1	5-5
5.2.2 Run Chain 1 - Manual Stop Circuit.....	5-6
5.2.3 Run Chain 1 - General Stop (GS) Circuit.....	5-7
5.2.4 Run Chain 1 - Emergency Stop (ES) Circuit.....	5-8
5.2.5 Run Chain 1 - Limit (LIM) Circuit.....	5-9
5.2.6 Run Chain 1 - Completion.....	5-10
5.2.7 Run Chain 2	5-11
5.2.8 Run Chain 2 - Manual Stop Circuit.....	5-12
5.2.9 Run Chain 2 - General Stop Circuit.....	5-13
5.2.10 Run Chain 2 - Emergency Stop Circuit.....	5-14
5.2.11 Run Chain 2 - Limit Circuit.....	5-15
5.2.12 Run Chain 2 - Completion.....	5-16

5.3 AUTO Mode Circuit	5-17
------------------------------------	-------------

5.3.1 Run Chain 1	5-17
-------------------------	------

Table of Contents (Cont)

	5.3.2 Run Chain 2	5-18
5.4	Component Cross Reference	5-19
5.5	List of Circuit Diagrams	5-21
5.6	Component Location Figures	5-29
	Figure 5-1 Computer System and System Board.....	5-29
	Figure 5-2 Back Plane AP80	5-31
	Figure 5-3 System Board K1CR & K2CR.....	5-33
	Figure 5-4 Control Cable XS1	5-35
	Figure 5-5 Customer Connections XS3/XT3 & AP41....	5-37
	Figure 5-6 Operator's Panel	5-39
	Figure 5-7 Power Unit	5-41
	Figure 5-8 R1.MP	5-43
	Figure 5-9 Teach Pendant.....	5-45
6.	Emergency Stop.....	6-3
6.1	Overview	6-3
6.2	Emergency Stop - Run Chain 1	6-4
6.3	Emergency Stop - Run Chain 2	6-6
6.4	Emergency Stop - Reset Circuit	6-8
6.5	Component Cross Reference	6-9
6.6	List of Circuit Diagrams	6-11
6.7	Component Location Figures	6-15
	Figure 6-1 Teach Pendant.....	6-15
	Figure 6-2 Computer System & System Board.....	6-17
	Figure 6-3 Back Plane AP80	6-19
	Figure 6-4 Operator's Panel	6-21
	Figure 6-5 Customer Connections XS3/XT3.....	6-23
7.	Power Unit.....	7-3
7.1	Overview	7-3
7.2	KM1	7-4
7.3	KM2	7-5
7.4	KM3	7-6
	<i>Diagram 7-1 Rectifier Board</i>	<i>7-7</i>
7.5	KM4	7-8
7.6	Component Cross Reference	7-9
7.7	List of Circuit Diagrams	7-11
7.8	Component Location Figures	7-17
	Figure 7-1 Power Unit	7-17
	Figure 7-2 XS3/XT3 and Connectors AP41 & AP9.....	7-19
	Figure 7-3 K1CR & K2CR on System Board.....	7-21
8.	Brake Circuitry	8-3
8.1	Overview	8-3
8.2	Manual Brake Release Circuit	8-4
8.3	Motors ON Brake Release	8-5
8.4	Component Cross Reference	8-7

Table of Contents (Cont)

8.5	List of Circuit Diagrams	8-9
8.6	Component Location Figures	8-23
	Figure 8-1 Power Unit	8-23
	Figure 8-2 System Board	8-25
	Figure 8-3 Robot Brake Buttons.....	8-27
	Figure 8-4 Power System Board Connections.....	8-29
	Figure 8-5 Robot Axes	8-31
9.	Motor & Resolver Circuitry	9-3
9.1	Overview	9-3
	<i>Diagram 9-1 Closed Loop System</i>	<i>9-3</i>
9.2	Computer	9-4
	9.2.1 Main Computer.....	9-4
	9.2.2 Memory Board.....	9-4
	9.2.3 Robot Computer.....	9-5
9.3	Drive System Boards	9-6
	9.3.1 Rectifier.....	9-6
	<i>Diagram 9-2 Rectifier</i>	<i>9-6</i>
	9.3.2 Drive Unit	9-8
	<i>Diagram 9-3 Drive Board</i>	<i>9-8</i>
9.4	Motors	9-9
	<i>Diagram 9-4 Simplified Motor</i>	<i>9-9</i>
	<i>Diagram 9-5 'Y' Motor Wiring Configuration</i>	<i>9-10</i>
9.5	Resolver	9-12
	<i>Diagram 9-6 Resolver Coil Relationships</i>	<i>9-12</i>
9.6	Serial Measurement Board (SMB)	9-13
9.7	Component Cross Reference	9-15
9.8	List of Circuit Diagrams	9-17
9.9	Component Location Figures	9-31
	Figure 9-1 Back Plane AP80	9-31
	Figure 9-2 Drive System Boards	9-33
	Figure 9-3 Robot Axis Motors.....	9-35
	Figure 9-4 Drive Connectors	9-37
10.	Calibration Procedures	10-3
10.1	Overview	10-3
10.2	"Rough" Resolver Calibration Procedure	10-4
10.3	Manually Entering Calibration Values	10-10
10.4	Precision Resolver Calibration Procedure	10-14
	10.4.1 Calibrating Axis 1	10-15
	10.4.2 Calibrating Axis 2-6	10-16
10.5	Counter Updating Procedure	10-23
11.	Inputs & Outputs	11-3
11.1	Overview	11-3
11.2	I/O Boards	11-4
	11.2.1 Digital I/O Board DSQC 223.....	11-4
	11.2.2 Analog I/O Board DSQC 209.....	11-5

Table of Contents (Cont)

11.2.3	Combined I/O Board DSQC 315.....	11-6
11.2.4	Remote I/O Board DSQC 239.....	11-7
11.3	Board Connections	11-8
11.3.1	External I/O Connections (Conn. option 31X)....	11-9
11.3.2	Internal I/O Connections (Conn. option 34X)....	11-13
11.3.3	Relay Unit (Conn. option 37X).....	11-16
11.3.4	120 VAC Modules (Conn. option 35X).....	11-18
11.3.5	Manually Operated I/O.....	11-19
11.4	Component Cross Reference	11-21
11.5	List of Circuit Diagrams	11-23
11.6	Component Location Figures	11-41
	Figure 11-1 XS3/XT3	11-41
	Figure 11-2 Screw Terminals	11-43
	Figure 11-3 120 VAC I/O Connector.....	11-45
A.	ERROR MESSAGES	A-2
A1.	Indicating Errors	A-2
A2.	Types of Error Messages	A-3
A3.	Error Codes	A-7
A3.1	Operational Error Messages.....	A-7
A3.2	System Error Messages.....	A-9
A3.3	Hardware Error Messages.....	A-16
A3.4	Programming Error Messages.....	A-35
A3.5	Motion Error Messages.....	A-59
A3.6	Operator Error Messages.....	A-67
A3.7	I/O & Communication Error Messages.....	A-69
B.	PARTS LISTS.....	B-3
B1.	Control System Parts List	B-3
B1.1	Power Supply Side.....	B-3
B1.2	Operator's Panel	B-3
	B-3	
B1.3	Teach Pendant.....	B-4
B1.4	Contacting Unit.....	B-4
B1.5	Computer System.....	B-4
B1.6	Drive System.....	B-5
B1.7	Optional Units.....	B-5
B1.8	Miscellaneous	B-6
B2.	Suggested Spare Parts List	B-7
B2.1	Axis 1	B-7
B2.2	Axis 2 & 3.....	B-7
B2.3	Lower Arm.....	B-7
B2.4	Upper Arm.....	B-8
B2.5	Cables	B-8
B2.6	Control	B-9
C.	CONNECTORS & CABLES.....	C-3
C1.	Robot Arm Cables	C-3
C2.	Control Cabinet Cables	C-4

Table of Contents (Cont)

C3.	Miscellaneous Cables	C-6
C4.	Signal Cable, Axis 1	C-7
C5.	Signal Cable, Axis 5	C-8
C6.	Power Cable, Axis 5	C-9
C7.	Signal Cable, Axis 6	C-10
C8.	Power Cable, Axis 6	C-11
C9.	Signal Cable, Axis 2	C-12
C10.	Power Cable, Axis 2	C-13
C11.	Signal Cable, Axis 3	C-14
C12.	Power Cable, Axis 3	C-15
C13.	Control Cable, Signal	C-16
C14.	Control Cable, Power	C-17
C15.	Customer Cable, Signal	C-18
C16.	Customer Cable, Power	C-19
C17.	Lower Cable Assembly	C-20
C18.	Upper Cable Assembly	C-22
C19.	Cable, Customer Connection	C-24
C20.	Cable, M94A	C-25
C21.	Cable, M94A Control Wiring X-Reference	C-30
C22.	Connectors	C-35
D.	GLOSSARY	D-1
E.	CIRCUIT DIAGRAMS	E-3
E1.	Sheet Numbering	E-3
E2.	Connector Labeling	E-4
E3.	Component Labeling	E-5
E4.	Sheet Referencing	E-6
E5.	Relay Labeling	E-7
E6.	Key Switch Contacts	E-8
E7.	Symbols and Abbreviations	E-9

INTRODUCTION

This Troubleshooting Manual provides the data and procedures required to service the ABB Flexible Automation IRB6400 Industrial Robot with S4 Control. Additional supplemental manuals specific to special features may also have to be referred to if such special features and equipment are a part of the robot purchase. Such manuals are included with these features.

This manual is specific to IRB6400 robots having schematic wiring diagram number CAB M94A-50xxx-00.

This manual was written to be part of an instructor-guided training program for experienced electricians only. The robot owner/user is responsible for the training of personnel to safely and successfully service the IRB6400 Industrial Robot.

The data contained in this manual was originated by and is the exclusive property of ABB Flexible Automation. The manual is furnished for owner/user information only and is neither a license for reproduction nor an authorization to furnish the information to others.

Personnel servicing the IRB6400 Industrial Robot shall read and comply with the contents of this manual and all other manuals pertaining to the IRB6400. If questions arise, contact the regional sales and service office at **1-800-457-6268**, for the address and phone number of ABB Flexible Automation, Industrial Robot Division.

IDENTIFICATION

Identification plates indicating the type of robot and manufacturing number, etc., are located on the rear of the robot's lower arm (see Figure 1) and on the front of the controller above the operator's panel (see Figure 2). The installation and system diskettes are also marked with the robot type and manufacturing number (see Figure 3).

ABB Flexible Automation		Made in Sweden
Type-Manufacturing no. M94A		
Nom load see instructions		
Net weight IRB 6400 /		
2.4-120	:	1825 KG
2.4-150, 2.8-120	:	1950 KG
3.0-75	:	1950 KG
S /2.9-120	:	2450 KG
PE /2.25-75	:	1524 KG
Type IRB 6400 /2.4-120		

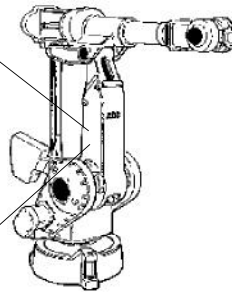

Figure 1. Identification plate on the manipulator.

Figure 2. Identification plate on the control panel.

ABB Flexible Automation	
Type	IRB 6400/M94A
Voltage	3 x 475 V
Frequency	50-60 Hz
Power	6.7 kVA
Ref.No	RXXX XXXX
Man.No	A 31023
Net weight	300 kg
Type: 6400 /2.4-120	
6400-XXXX	
Label with manufacturing number.	

Label with type

<p>ABB</p> <p>S4 / M94A program</p> <p>Program No3HAB XXXX-X</p> <p>Boot Disk1 (2)</p> <p>Serial NoIRB 6400-XXXX</p> <p>Property of ABB Vasteras/Sweden. All rights reserved. Reproduction, modification, use or disclosure to third parties without express authority is strictly forbidden. Copyright 1994.</p> <p>Authorized to be used in the controllers with the above stated serial no.</p> <p>ABB Flexible Automation</p>
--

Figure 3. Label on a system diskette

The serial numbers can be found in the locations indicated in the illustrations. These numbers must be referenced in all matters concerning the robot.

MAINTENANCE

What You Must Know Before You Use The Robot

Normal maintenance and repair work usually only requires standard tools. Some repairs, however, require specific tools. A list of suggested Hand Tools is included in this introduction.

The main disconnect should be switched off whenever work is carried out in the control cabinet. Note that even though the power is switched off, the orange/yellow colored cables may be live. The reason for this is that these cables are connected to external equipment and are consequently not affected by the main switch on the controller.



Circuit boards (printed boards and components) must NEVER be handled without Electro-Static-Discharge (ESD) protection such as a wrist strap, in order not to damage them. Use the carry bag located on the inside of the controller door.



All personnel working with the robot system must be very familiar with the safety regulations outlined in Chapter 1 (Safety). Incorrect operation can damage the robot or injure someone.

TOOLS

The need for special tools has been reduced to a minimum. When tools are needed for assembly/disassembly, a description is given in the Assembly/Disassembly Guidelines Manual. During the ordinary service training courses arranged by ABB Flexible Automation, detailed descriptions of the tools are given together with their use.

Suggested Hand Tools

Hex bits 4,5,6,7,8,10 mm 3/8 drive
Bondus-Balldriver Set (Metric)
3pc. Plier Set
Industrial Screwdriver Set (8pc)
Electricians Knife

8" Adjustable Wrench
3" Adjustable Wrench
Pick-up Tool Magnetic Telescopic

Soldering iron
Desoldering Wik
Solder Brush & Scraper Tip

Crimper/stripper
Small Diagonal Cutters
7pc Torx set T15-T50
Hex Bit 14mm
Hex Bit 17mm
Torx Bit T7

Oscilloscope / Digital meter
Channel lock small
Channel lock large
Small adjustable wrench
Flash light

Electrical tape
Electrical Solder
Tie wraps (assortment)
Snap ring pliers

THIS MANUAL

This manual provides a guide to electrically troubleshoot the IRB 6400 M94A controller. It was written for trained maintenance personnel with experience in electrical systems. The manual does not in any way assume to take the place of the maintenance course offered by ABB Flexible Automation.

It is assumed that the user of this manual has a working knowledge of the system operations and basic programming skills.

If a problem occurs:

- 1) Check for errors. This is done by use of the error log which is explained in Appendix A (Error Messages).
- 2) Go to the appropriate chapter and troubleshoot the problem described. (Refer to Chapter Descriptions on the next page for the proper chapter.)
- 3) If no error code is present, then use the chapter called *Computer* to diagnose the problem using the system LED's.
- 4) If a problem is in the Servo System, be sure to eliminate mechanical binding as a possible cause first.

CHAPTER DESCRIPTIONS

The chapters of this manual are:

1. SAFETY

Describes the proper safety procedures to follow to perform work on the robot and controller.

2. COMPUTER SYSTEM

This chapter describes the components of the computer and explains how the computer system operates. It also explains all diagnostic LEDs and troubleshooting procedures for the computer system.

3. LOADING SYSTEM SOFTWARE

Describes the procedure for properly loading the computer with system software.

4. POWER ON CIRCUITRY

Describes all circuits effected when the main disconnect is turned ON.

5. MOTOR ON/DUAL RUN CHAIN

Describes all circuits used in the Dual Run Chain circuits and how to troubleshoot the Dual Run Chain circuit.

6. E-STOP

Describes the circuits used in the Emergency Stop circuits of the system.

7. POWER UNIT

Describes the circuits of the Power Unit located on top of the Swing Gate.

8. BRAKE CIRCUITRY

Describes the operation and circuit of the robot's Brake System.

9. MOTOR & RESOLVER CIRCUITRY

Describes the operation and circuits of the Servo System. Also covered in this chapter are the Resolvers. This chapter explains troubleshooting procedure for this system.

10. CALIBRATION PROCEDURES

Describes the calibration procedures.

11. INPUTS & OUTPUTS

Describes the components used in the I/O system. Along with the proper wiring of Inputs and Outputs. Also covered in this chapter will be how to monitor I/O Status and troubleshoot I/O problems.

APPENDICES DESCRIPTIONS

The Appendix of this manual consists of:

A. ERROR MESSAGES

Consists of a numerical listing of all the error messages in the system and a brief description of the cause of the error.

B. PARTS LISTS

Contains a list of parts for the Control Cabinet, and a recommended list of spare parts.

C. CONNECTORS & CABLES

Shows the location of all the cables in the system.

D. GLOSSARY

Explanation of various terms used within this manual and the industry.

E. CIRCUIT DIAGRAMS

A complete set of circuit diagrams needed for troubleshooting the IRB 6400 robot manipulator and Control Cabinet.

SIGNS AND SYMBOLS

This manual uses a number of symbols to emphasize a point or create an eye-catching reference to another point in the manual.

Following are descriptions for the symbols used.



CAUTION

This symbol is used to emphasize that care must be taken while proceeding with the step.



POINTER

This hand will show an important point or helpful information to make a job easier.



E-STOP

This symbol is used to emphasize danger. The step should be taken with extreme care.

Sheet----- 

SHEET

This is used to tell the reader which Circuit Diagram Sheet to reference when taking the steps.

Fig. ----- 

FIGURE

This is used to tell the reader which Component Location figure to reference when taking the steps.

• **BULLET**

When examples are given for a subject, or a flow of reason, they will be shown by bullets (•).

- **DASH**

When a flow of a circuit is explained, they will be shown by a dash ().

CHAPTER I

SAFETY

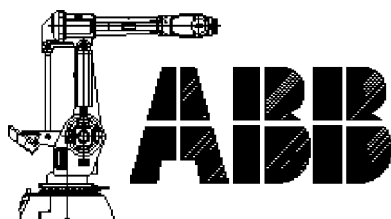

Safety

Table of Contents

1.	Safety	1-3
1.1	General Safety	1-4
1.2	Safety Features	1-5
1.3	Safety Guidelines	1-6
1.4	Safety During Maintenance	1-8
1.5	Safety During Programming	1-8
1.6	Safety Control Chain of Operation	1-9
1.7	Risks Associated with Live Parts	1-11
1.8	Limitation of Liability	1-12
1.9	Related Information	1-12

NOTES

I. Safety

IMPORTANT



The following safety precautions for the ABB Flexible Automation IRB6400 Industrial Robot have been prepared to help the operator and maintenance personnel in practicing good shop safety procedures

Operating and maintenance personnel should read and understand these precautions completely before operating, setting up, running, or performing maintenance on the machine.

These precautions are to be used as a guide to supplement the safety precautions and warnings in the following:

- a) All other manuals pertaining to the robot.
- b) Local, plant, and shop safety rules and codes.
- c) Federal and National safety laws and regulations.

See the latest edition of the OCCUPATIONAL SAFETY AND HEALTH STANDARDS, available from the DEPARTMENT OF LABOR, WASHINGTON D.C.

Read all safety precautions before operating the robot. Failure to follow safety instructions may result in personal injury and/or damage to machine components.

The information in this manual does not discuss how to design, install or operate a complete system. It does not cover external equipment not supplied by ABB.

ABB has supplied the robot with numerous interfaces for external safety equipment. It is highly suggested that any place a safety device can be connected, should be. ABB is not responsible for the lack of external safety devices or any concerns if the external safety devices are manually bypassed.

The robot is designed in accordance with the requirements of ISO10218, Jan. 1992, Industrial Robot Safety. The robot also fulfills the ANSI/RIA 15.06-1992 stipulations.



Use a CARBON DIOXIDE Fire Extinguisher (used for electrical fires) on the robot (manipulator or controller) should a fire occur.

1.1 General Safety

The user of an ABB robotic system has the final responsibility for the safety of personnel working with the system. The safety procedures used should be appropriate to the level of danger and risk associated with the particular installation. These safety procedures should include all of the precautions described below and any additional safety measures appropriate to the particular installation, including the shop or plant safety rules normally in effect.

The robot should be approached with the same caution as any other industrial machine. Although ABB robots are designed for the greatest possible safety, no machine is completely safe and it is impossible to entirely eliminate the human factor.

This robot was designed with safety in mind. It has a dedicated safety system based on a two-channel circuit which is monitored continuously. If an error occurs, the electrical power supplied to the motors shuts off and the brakes engage.

For additional information about robot safety, see American National Standard for Industrial Robots and Robot Systems, ANSI/RIA R15.06-1992.



LOCK-OUT protection should be used whenever power is not required on the robot system.

1.2 Safety Features

- **Selection of Operating Mode**

The robot can be operated either manually or automatically. In Manual mode, the robot can only be operated using the teach pendant, not by any external equipment.
- **Reduced Speed**

The speed can be limited to a maximum of 250 mm/s. A speed limitation applies not only to the Tool Center Point (TCP), but to all parts of the robot. It is also possible to monitor the speed of equipment mounted on the robot.
- **Overspeed Protection**

The speed of the robot is monitored by two independent computers.
- **Emergency Stop (E-Stop)**

There is one emergency stop push button on the control panel, and another on the teach pendant. Additional emergency stop buttons can be connected to the robot's safety chain circuit.
- **Safeguarded Space Stop**

These include: Manual Stop, Auto Stop, General Stop, E-Stop, Limit Stop. The robot has a number of electrical inputs which can be used to connect external safety equipment, such as safety gates and light curtains. This allows the robot's safety functions to be activated both by peripheral equipment and by the robot itself.
- **Delayed Safeguarded Space Stop**

Such as a Hold circuit. A delayed stop gives a smooth stop. The robot stops in the same way as a normal program stop with no deviation from programmed path. After 1-2 seconds the power supplied to the motors shuts off.
- **Restricting the Working Space**

The movement of each of the axes 1-6 can be restricted using software limits. Axes 1-3 can also be restricted by means of an adjustable mechanical stop. Axis 1 & 2 can be restricted using an Electrical Limit switch.
- **Enabling Device**

You must use the Enabling Device on the Teach Pendant to start the motor before you can move the robot when in Manual modes. The Enabling Device has a switch with three positions, meaning that all robot movements stop when either the Enabling Device is pushed fully IN, or when it is released completely. This makes the robot safer to operate.

1.3 Safety Guidelines

When working with any robot system, observe the following safety guidelines:

- Keep the operator work area clean at all times.
- Know the location of all EMERGENCY STOP buttons and POWER ON/OFF switches that may have to be used quickly.
- Make sure that each person directly responsible for the operation of the robot system has a thorough knowledge of all safety procedures and practices. Keep all gate-access openings to the robot closed and properly secured during operation.
- Keep in mind that there is always an element of risk when approaching a moving robot. The robot exerts considerable force even when moving slowly.
- Be aware that when the system is in the RUN mode, the robot may begin to move unexpectedly at any time without warning. A robot program contains many instructions that control the movement of the robot. For example, a pause or slow movement pattern may be followed immediately by rapid acceleration to a high speed movement. Signals from peripheral equipment can also affect the sequence of instructions sent to the robot. A repeating pattern of movement can change abruptly without warning.
- Avoid working alone within the work envelope of the robot when the system is in the RUN mode. One person should remain outside the envelope with the sole responsibility of activating the EMERGENCY STOP button in case a dangerous situation should arise.

Safety Guidelines (Cont)

If you have to be within the work envelope of the robot:

- Make sure that the entire work cell has been prepared for safe operation before running the robot system. Correct all abnormal conditions of the robot system and peripheral equipment before start up. Notify your supervisor or trained maintenance personnel of any abnormal condition that you cannot rectify yourself.
- Make sure that the robot system is in the **MOTORS OFF** mode for as long as possible. MOTORS OFF mode means that drive power is removed from the robot's motors and the brakes are applied. Keep program execution to a minimum, and return to MOTORS OFF as soon as possible.
- Select Manual Reduced Speed with the operation mode selector switch on the front of the robot control cabinet. Remove the programming unit from its storage compartment in the control cabinet and carry it (with the Enable Device released) into the work envelope of the robot. This ensures that operating power to the robot motors is disconnected and the robot is in the MOTORS OFF mode.
- Always wear protective clothing and equipment specified by safety regulations. In general, loose-fitting clothes such as ties, scarves, arm bands, etc., should not be worn near the robot system.

1.4 Safety During Maintenance

When performing maintenance on the robot system, all of the previous safety guidelines should be in effect as well as the following:

- Make sure that all persons within the work envelope are thoroughly familiar with the performance characteristics of the robot and its potential hazards.
- When working on the robot controller or while the robot is in the production mode, make sure that the work envelope is clear of personnel.
- Always disconnect main power and 'Lock-Out' the switch box before inspection.
- Replace all equipment-service covers after performing a maintenance procedure.
- Always have an escape path planned.
- Never slow or stop the robot with any body part or makeshift device.
- Removal or loss of air pressure may result in moving mechanisms. Appropriate precautions must be taken to prevent equipment damage or personal injury in such cases.

1.5 Safety During Programming

When programming the robot, all of the above safety guidelines should be in effect as well as the following:

- The robot system must be under the sole control of the programmer.
- Only the programmer is allowed in the restricted work envelope.
- Movement of equipment into the work envelope must be under the sole control of the programmer.
- The robot must always be operated at slow speeds except when a higher speed is needed for program verification.
- The programmer must always be outside the restricted work envelope of the robot before initiating the automatic mode of operation.

1.6 Safety Control Chain of Operation

The safety control order of operation is based on dual electrical safety circuits (Run Chains) which interact with the robot computer and enable the **MOTORS ON** mode.

The electrical safety circuits consist of several switches connected in series, in such a way that ALL of them must be closed before the robot can be set to **MOTORS ON** mode. **MOTORS ON** mode means that power is supplied to the motors.

The electrical safety chains are continuously monitored and the robot reverts to the **MOTORS OFF** mode when a fault is detected by the computer. **MOTORS OFF** mode means that drive power is removed from the robot's motors and the brakes are applied.

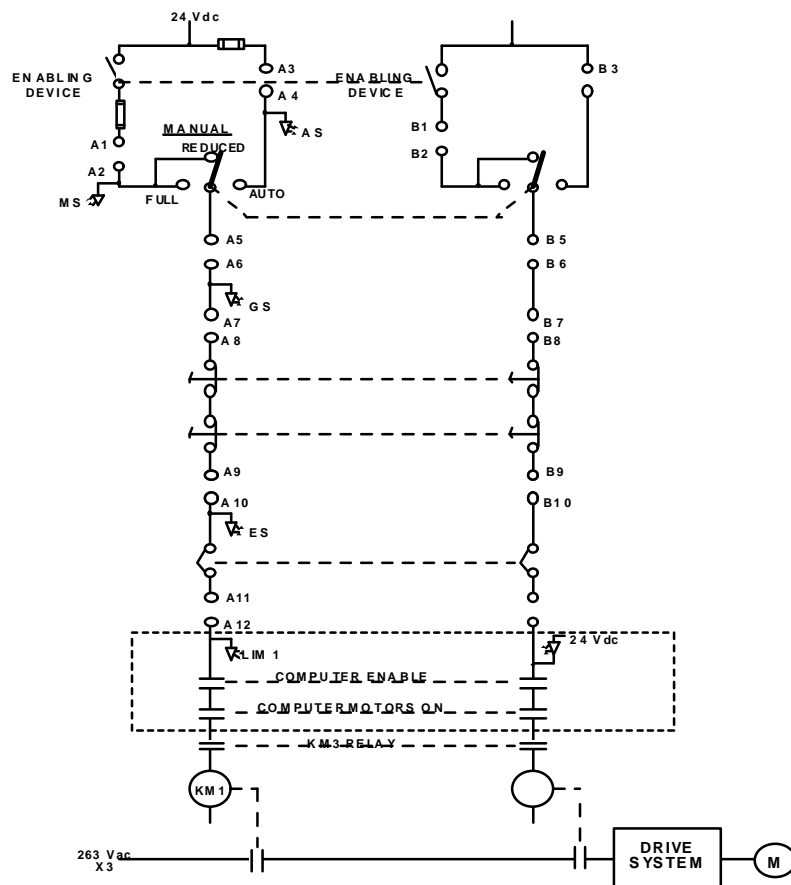

Safety Control Chain of Operation (Cont)

The status of the switches are indicated by the LEDs on the front of the System board (DSQC 256A) in the Control Cabinet.

If any contact in the safety chain of operation is open, the robot always reverts to the **MOTORS OFF** mode.

After a stop, the switch must be reset at the specific unit which caused the stop. After reset, the robot can be started again.



The safety chains must never be bypassed, modified or changed in any other way.

1.7 Risks Associated with Live Parts



Controller

A danger of high voltage is associated with the following parts:

- The mains supply/mains switch
- The power unit
- The power supply unit for the computer system (220 V AC)
- The rectifier unit (240 V AC and 340 V DC. **Especially Capacitors!**)
- The drive unit (340 V DC)
- The service outlets (110/220 VAC)
- The power supply unit for tooling, or special power supply units for the machining process.
- The external voltage connected to the control cabinet remains live even when the robot is disconnected from the mains.
- Additional connections

Manipulator

A danger of high voltage is associated with the manipulator in:

- The power supply for the motors (up to 340 V DC)
- The user connections for tooling or other parts of the installation.

Tools, Material Handling Devices, etc.

Tooling, material handling devices, etc., may be live even if the robot system is in the **OFF** position. Power cables which are in motion during the working process may be damaged.

1.8 Limitation of Liability

The previous information regarding safety must not be construed as a warranty by ABB Flexible Automation that the industrial robot will not cause injury or damage even if all safety instructions have been complied with.

1.9 Related Information

Described in:

Installation of safety devices IRB 6400 Product Manual
Chapter 7 - Installation and
Commissioning
ABB Part #3HAB 0009-55

Changing robot modes Basic Operation Manual
Chapter 3 - Operators's Panel
ABB Part #3HAB 0002-30

Limiting the working space IRB 6400 User's Guide
Chapter 9 - System
Parameters
ABB Part #3HAB 0002-24

IRB 6400 Product Manual
Chapter 7 - Installation and
Commissioning
ABB Part #3HAB 0009-55

Digital system signals IRB 6400 User's Guide
Chapter 9 - System
Parameters
ABB Part #3HAB 0002-24

CHAPTER 2

COMPUTER SYSTEM



Computer System

Table of Contents

2.	Computer System	2-3
2.1	Overview	2-3
	<i>Diagram 2-1 Computer System and System Boards ...</i>	<i>2-3</i>
2.2	System Description	2-4
	<i>Diagram 2-2 Block Diagram</i>	<i>2-5</i>
2.3	Troubleshooting	2-6
2.3.1	General	2-6
2.3.2	Diagnostics	2-8
2.4	Board Descriptions	2-10
2.4.1	Robot Computer DSQC 326	2-11
2.4.2	Main Computer DSQC 316	2-12
2.4.3	Memory Board DSQC 317/6 Mb (DSQC 321/4Mb)	2-13
2.4.4	Power Supply Unit DSQC 258	2-14
2.4.5	System Board DSQC 256A	2-15
2.4.6	Digital I/O Board DSQC 223	2-17
2.4.7	Combined I/O Board DSQC 315	2-18
2.4.8	Analog I/O Board DSQC 209	2-19
2.4.9	Remote I/O Board DSQC 239	2-20
2.4.10	Axis Board DSQC 233	2-21
2.5	Serial Measurement Board (SMB)	2-22
2.6	Teach Pendant	2-23
2.7	Component Cross Reference	2-24
2.8	List of Circuit Diagrams	2-25
2.9	Component Location Figures	2-47
	Figure 2-1 Control Cabinet.....	2-47
	Figure 2-2 Connectors	2-49
	Figure 2-3 SMB	2-51
	Figure 2-4 Back Plane AP80.....	2-53
	Figure 2-5 Teach Pendant	2-55

NOTES

2. Computer System

2.1 Overview

The brain of the S4 (Series 4) controller is located on the bottom of the swing gate. This brain consists of several computer boards all connected together by a back plane. In this chapter the overall operation of the computer system will be explained along with a description of each individual board in the system. Also described in this chapter will be troubleshooting procedures. Diagram 2.1 shows the computer system and the boards in the computer, followed by a basic description of each board in the system.

Diagram 2-1 Computer System and System Boards

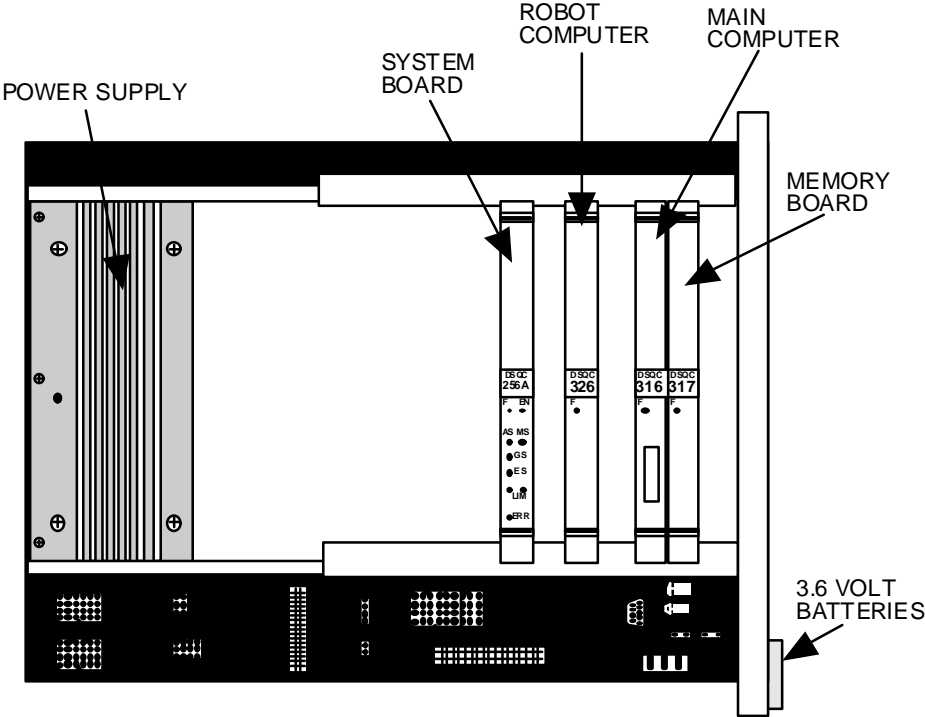

2.2 System Description

The S4 computer system consists of the following components:

Main Computer. This board is the “BIG BOSS” of the system. The main computer performs all high level decision making. It runs the application program and creates the motion “poses” that the system uses for to get through its program.

Robot Computer. This board actually contains two computers, the Servo computer and the I/O computer. This board controls the Drive system and also controls all I/O communications.

Memory Board. There are two different memory boards available for the S4 system. One has 4MB and the other has 6MB of RAM. The type of board used depends upon customer requirements.

Battery Back-up. The computer system is battery backed by two 3.6 volt lithium batteries located below the computer boards and plugged into the back plane. The robot computer will switch between the batteries to always have battery back-up protection.

System Board. This board has all of the safety circuits contained on it. It contains both of the Run Chain circuits and also Motor Temperature circuits. Also contained on this board are the sensor inputs.

Power Supply. The power supply provides the DC voltages needed to operate all computer boards and also supplies the 24 VDC which is the source voltage for most components in the system.

I/O Boards. There are several different I/O boards available for the S4 system. These inputs and outputs are for the customers use to be interfaced with external equipment such as PLC, valves, or switches.

PWM Drive System. The drive system is controlled by the robot computer and regulates power to the motors.

Motors. They do the work of the system. They cause the robot to move to the commanded positions.

Resolvers. The Resolvers are the position feedback device. They feedback an analog signal that represents the angular position of the motor.

Serial Measurement Board (SMB). Reads the resolver feedback, converts it to digital, and sends the position information back to the robot computer.

Teach Pendant. The Teach Pendant is the device used by humans to interface with the computer.

Diagram 2-2 Block Diagram

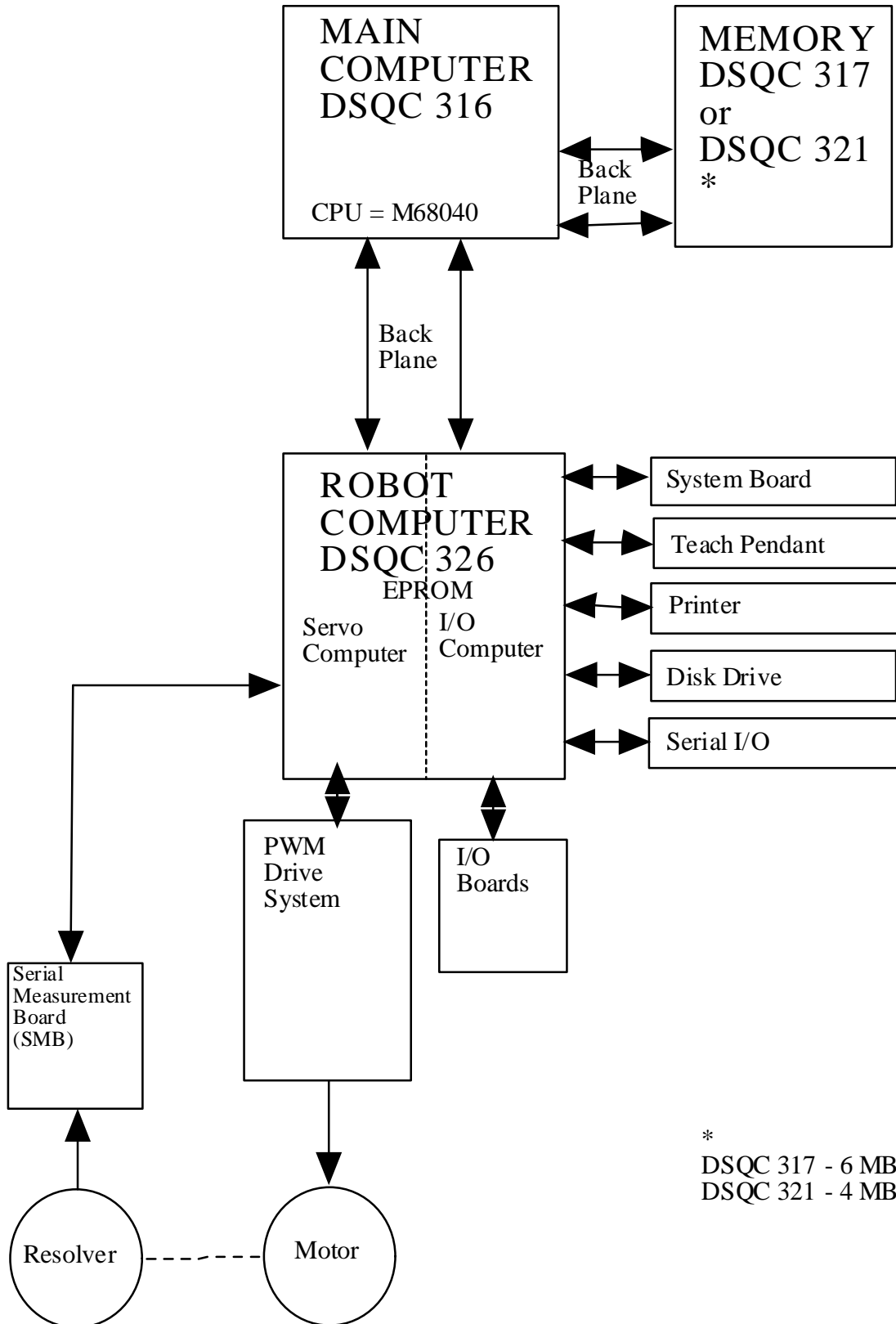

*
DSQC 317 - 6 MB
DSQC 321 - 4 MB

2.3 Troubleshooting

2.3.1 General



ESD ALERT!! ESD ALERT!!

In this computer system ALL computer boards are static sensitive.

'ESD' is Electro Static Discharge.

ESD is the charge you get from walking across a new carpet floor and then touch an object with a different potential.

In the case of carpeting, this voltage is very, very high.

ESD is on our bodies at ALL times. There is enough voltage to damage computer board electronics when it is discharged through them.

Fig. 2-1 →



IT IS CRITICAL THAT BEFORE HANDLING ANY COMPUTER BOARD TO PUT ON THE GROUND STRAP THAT IS ATTACHED TO THE SWING GATE OF THE CONTROL CABINET.

This applies to all boards in the system. If you need to put a board down or carry it to another location put it into the special static free bag that comes with each controller first.



If this procedure is not followed every time a board is handled damage **WILL** be done to the board even if no apparent damage is evident.



Never remove any computer component with power ON.

In general, when troubleshooting the system begin by:

- 1) Reading any error messages shown on the teach pendant display.
- 2) Check the systems error log by
 - a) pressing MISC
 - b) selecting Service
 - c) press View
 - d) select Error Log
- 3) Check the LEDs on the front of the boards in the system. The LEDs will indicate board failures. The LEDs are explained later in this chapter.
- 4) Try restarting the system. When the system is restarted the computer runs diagnostics that can be helpful when troubleshooting. Also restarting resets the system software.
- 5) If needed check wiring by using the circuit diagrams.
- 6) Remember to check for mechanical problems.

Troubleshooting (Cont) General (Cont)

NEVER start off by wildly replacing boards or units, this can result in the destruction of good boards in the system. Try to narrow a problem down to a single component causing a problem.

PROBLEMISOLATION:

When troubleshooting the system a problem can be isolated by indications of operation that determine the type of problem that is occurring.

These indications are:

Control has power. This is most easily noticed by looking for LEDs on the computer boards and display on the teach pendant when the disconnect is turned on. If a problem exists here, check circuit diagrams and trace incoming power to the power supply and the power supply voltages. Refer to the Power ON chapter in this manual.

Computer is operating. This is noticed by checking for the welcome display on the teach pendant and checking for the "EN" LED on the system board. If a problem exists here, check error code or check for LED indications in the next section of this chapter.

Motors ON. This is found by pulling the enable device to the center position and observing the Motors ON light. If a problem exists here, check the system board's LED's to see if the run chains are OK. Then check the circuit diagrams for problems. Refer to the Motors On chapter of this manual.

Robot moves. This is checked by use of the joystick to move each axis individually. If an axis movement causes a fault, then troubleshoot the problem for that axis. Refer to the Motors & Resolvers chapter of this manual.

Robot runs program. Start the normal program execution. If the program has a problem then the problem is possibly an interfacing problem. Refer to the I/O chapter in this manual.

Troubleshooting (Cont)

2.3.2 Diagnostics

To aid in troubleshooting, the computer system runs various tests when the controller is started up. These tests are stored on EPROM (Erasable Programmable Read Only Memory) chips on the robot computer board.

There are two different types of testing conditions. They are:

Cold start is executed when the system is powered up after a loss of memory. During a cold start, extensive self tests of the system are performed. The tests are displayed on the Teach Pendant as they are executed. If a problem is found, an error message will be displayed explaining the problem. A loss of memory can be caused by the removal of the Main, Robot, or Memory boards. Memory is also lost by turning power off and disconnecting both batteries from the back plane. A cold start can be forced from the teach pendant by pressing:

- a) MISC
- b) Service
- c) File
- d) Restart
- e) 1 3 4 6 7 9
- f) C-Start (Cold Start).

Warm start is the normal starting conditions where the memory has been battery backed-up and the system only performs a limited set of tests when started. Sometimes it can be beneficial to perform a cold start to find certain computer board faults.

Troubleshooting (Cont) Diagnostics (Cont)

Intermittent errors do, unfortunately, occur. These can be the hardest errors to troubleshoot. When troubleshooting this type of error, it is important to monitor the error code and the conditions that exist when the error occurs. Conditions that should be noted include the position that the robot is at, the environmental conditions that exist (very hot or cold or is the robot getting wet), and operations occurring at the same time the robot is having the problem. Such as heavy machinery nearby, or radio signals being sent, or welding process on the same power source as the robot.

It may be necessary to run test programs to isolate a problem. The program should duplicate conditions that are seen when the problem occurs. The purpose is to make the intermittent error happen regularly. Then troubleshoot the problem.

2.4 Board Descriptions

In this section of the manual each computer board in the system is described. With each description is a picture of the board and a description of the diagnostic LED(s) on that board and any procedures that must be performed if that board is replaced.

2.4.1 Robot Computer DSQC 326

<u>Designation</u>	<u>Color</u>	<u>Description</u>
--------------------	--------------	--------------------

F	Red	Turns OFF when the board approves the initialization.
---	-----	---

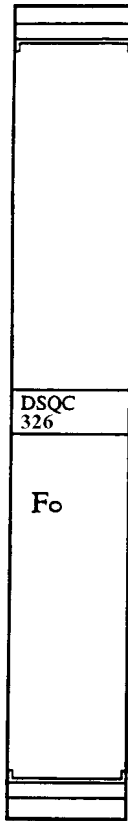

Fig. 2-1 ➤
 Fig. 2-4 ➤

The robot computer, controls the system's I/O, axis control, serial communication and teach pendant communication. It is the first unit to start after a cold or warm start. The red LED on the front of the board goes OFF immediately when the system is reset and goes ON again if an error is detected in the tests. The robot computer releases the main computer when the preliminary diagnostics have given the go-ahead signal.

The read and write memories of the robot computer are battery-backed.

If the system does not start at all and the LED on the robot computer goes ON, the error is probably in the robot computer, but may also be caused for other reasons indicated by the diagnostic messages.

It is not possible to carry out diagnostics on the board in the operation environment and, therefore, if the robot computer is faulty, it must be replaced.

If the Robot Computer board is **replaced**, take the EPROM chips from the old board and put them on the new board. **Insert the Robot Computer board in the correct slot.** (See Figure 2-4) The system software will then have to be loaded and the system parameters need to be loaded. Then the resolver counters need to be updated also. Refer to Chapter 3 - Loading System Software for procedures.

2.4.2 Main Computer DSQC 316

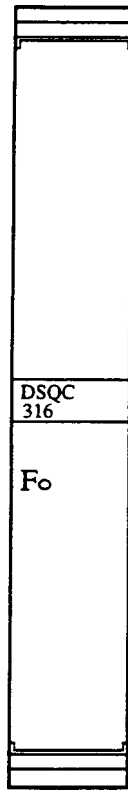

<u>Designation</u>	<u>Color</u>	<u>Description</u>
F	Red	Turns off when the board approves the initialization.

The main computer is connected to the VME bus (back plane) and the local bus of the memory expansion board. The main computer looks after the higher-level administrative work in the control system. Under normal operating conditions, all diagnostic monitoring is controlled by the main computer. At startup, regardless of whether a cold or warm start is performed, the robot computer releases the main computer when the robot computer's diagnostics allows it, then the main computer takes over control of the system. The read and write memories of the main computer are battery-backed.

If the red LEDs on the main computer light up (or do not go off at the initialization), either a critical system failure has occurred, or the main computer board or expansion memory is faulty.

It is not possible to carry out diagnostics on the board in the operation environment and, therefore, if the main computer is faulty, it must be replaced.

If the Main Computer board is to be replaced, the new board must go in the correct slot (see Figure 2-4). The system software will have to be loaded. Then the system parameters will have to be loaded. And then the resolver counts need to be updated. Refer to Chapter 3 - Loading System Software for procedures.

Fig. 2-4 ➡

2.4.3 Memory Board DSQC 317/6 Mb (DSQC 321/4Mb)

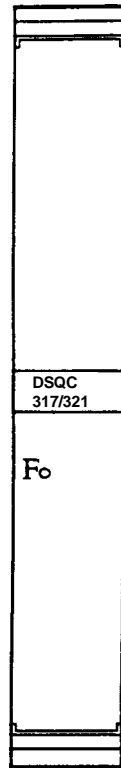

Fig. 2-4 ➡

<u>Designation</u>	<u>Color</u>	<u>Description</u>
F	Red	Turns off when the board approves the initialization.

The expansion memory, which is battery-backed, is an extension of the main computer's memory.

The communication between the main computer and the expansion memory takes place over a specific memory bus in the backplane from which the board is also supplied. Only one signal is carried over the VME bus (the upper connector), namely VSYSRESET-N.

The board has an LED, 'F', which is lit and turned OFF by the main computer. If the LED is lit, the board probably has a fault.

It is not possible to carry out diagnostics on the board in the operation environment and, thus, if the expansion memory is faulty, it must be replaced.

If the Memory board is to be replaced, the new board must go in the correct slot (see Figure 2-4). The system software will have to be loaded. Then the system parameters will have to be loaded. And then the resolver counts need to be updated. Refer to Chapter 3 - Loading System Software for procedures.

2.4.4 Power Supply Unit DSQC 258

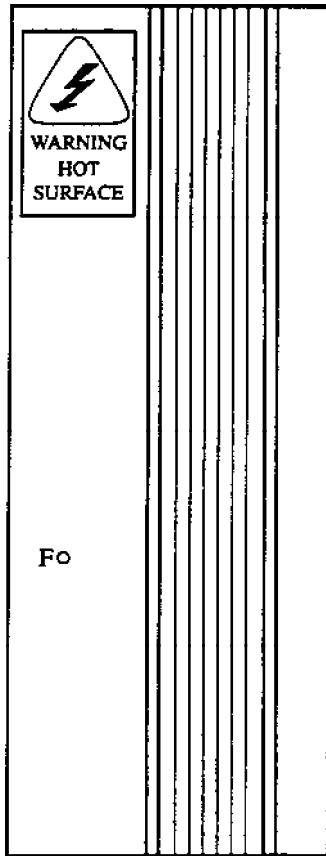

<u>Designation</u>	<u>Color</u>	<u>Description</u>
F	Red	Unlit: All supplies are within the appropriate limits (or there is no main supply).
		Flashing: Short-circuited +24V.
		Lit: +5V, +15V or -15V is short-circuited.

The Power Supply Unit is the source of power for the computer boards. The DC voltages go through the back plane. The Power Supply is short circuit protected. Which means that if any of the outputs are shorted, the power supply will drop the voltage until the short is fixed.

The DC voltages can be checked with a digital multimeter. There are no dedicated test points for these voltages. However, the following are suggested places to check these voltage levels:

<u>Voltage</u>	<u>Checkpoint</u>
+5 VDC	Back of power supply GS1.XP1 pin D32.
±15 VDC	Only able to check if an analog I/O board is used. Check on XT10 terminals 19-24 or on the front of a DSQC 209 board.
+24 VDC	Check on XS3/XT3 terminal A16.
0 VDC	XS3/XT3 terminal D16 or any metal surface in control should be grounded and 0 VDC

If the Power Supply is **replaced**, there are no adjustments or procedures necessary.

- Sheet 6, line 19
- Fig. 2-2
- Sheet 21.1, line 13.....
- Sheet 21.2, line 13.....

- Sheet 6, line 01
- Fig. 2-2
- Sheet 6, line 16
- Fig. 2-2

2.4.5 System Board DSQC 256A

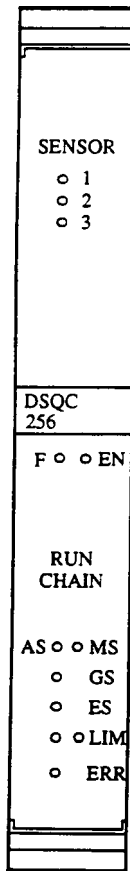

<u>Designation</u>	<u>Color</u>	<u>Description</u>
Sensors 1-3	Yellow	Lights when high signals are received from sensors 1-3. The LED shines more brightly the more voltage is input. This means that even if the input voltage is just under the voltage level "1", the LED will glow dimly.
F	Red	Turns OFF when the board approves the initialization.
EN	Green	Turns ON to indicate computer system is operating.
AS	Yellow	Turns ON when the Run Chain 1 circuits up to and including the automatic mode safeguard stop (AS) are closed.
MS	Yellow	Turns ON when the Run Chain 1 enabling device on the teach pendant is pressed halfway and the circuits up to and including the manual mode safeguard stop (MS) are closed.
GS	Yellow	Turns ON when the Run Chain 1 circuits up to and including the general mode safeguard stop (GS) are closed.
ES	Yellow	Turns ON when the Run Chain 1 circuits up to and including the emergency stop (ES) are closed.
LIM	Yellow	Turns ON when all circuits and limit switches are closed. The left LED indicates the status of Run chain 1 and the right of Run chain 2.
ERR	Red	Turns ON when one, but not the other KM1 or KM2 relay is energized.

System Board DSQC 256A (Cont)

Sheet 7
 Sheet 8

The DSQC 256A System board controls and reads the dual operation chain. Its status is also indicated by LEDs on the front of the board.

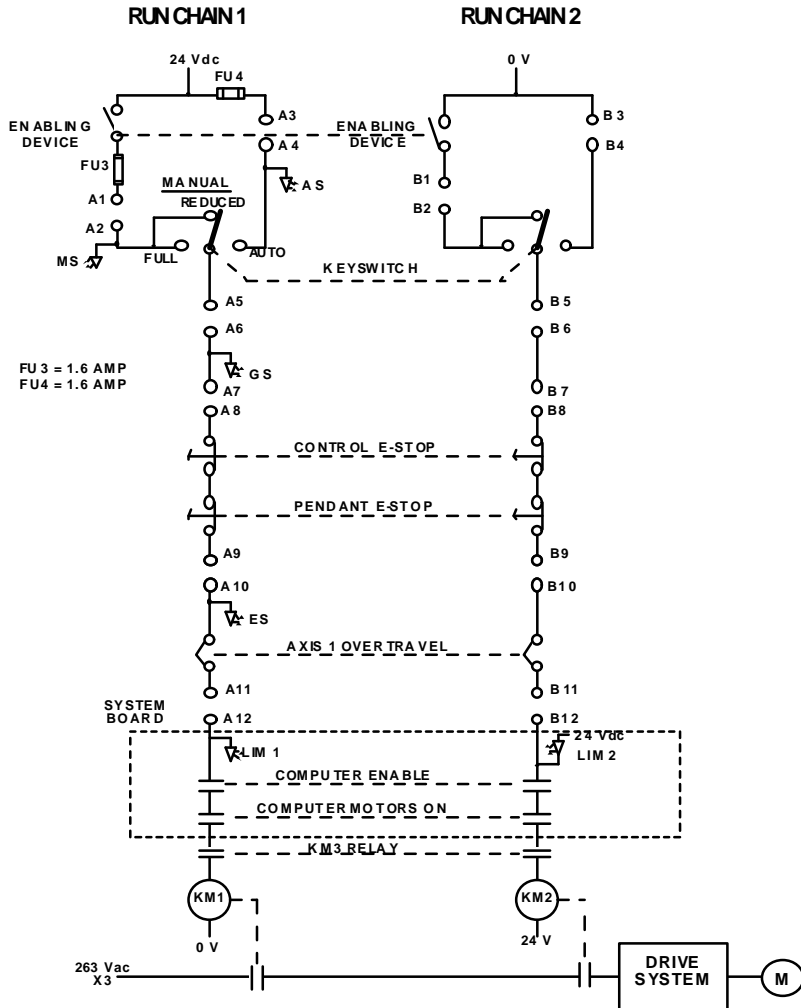

Sheet 8, line 01

The board has, in addition, three sensor inputs for inductive sensors. These inputs are scanned more often than standard inputs for faster response times.

Sheet 13.1, line 6.....

The temperature of the motors are monitored by PTC (Positive Temperature Coefficient) inputs to the board. The resistance of a PTC is approximately 120 Ohms at room temperature. If the motors gets extremely hot, this resistance will go high.

For troubleshooting procedures refer to the Motors ON chapter in this manual.

If **replaced**, there are no adjustments or procedures required.

2.4.6 Digital I/O Board DSQC 223

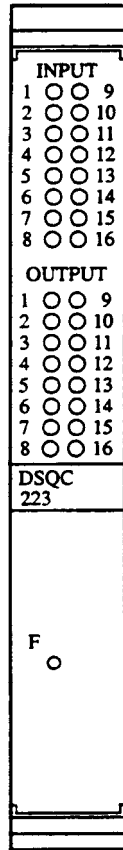

<u>Designation</u>	<u>Color</u>	<u>Description</u>
INPUT	Yellow	Turns ON when it receives a high signal from an input. The LED shines more brightly the more voltage is input. This means that even if the input voltage is just under the voltage level "1", the LED will glow dimly.
OUTPUT	Yellow	Turns ON when a high signal is sent from an output. The LED shines more brightly the more voltage is output.
F	Red	Turns off when the board approves the Initialization.

Sheet 6, line 01

The digital input and output board, DSQC 223, has 16 opto-isolated inputs and 16 opto-isolated outputs. Each input and output has its own yellow LED which indicates whether or not the input/output is activated. The inputs and outputs normally receive their 24VDC supply from a customer connection, but this can also be supplied internally (XS3/XT3 terminals A15,B15,A16,B16,C16. If none of the I/O channels work, check first that the boards are initialized (the red F-LED should be OFF on all I/O boards). Note that if, for some reason, the system's parameters change, the red LED may be ON. Otherwise, the red LED may indicate that the I/O boards are faulty.

Check also that the boards have a 24VDC supply (internal or external). Common sources of errors are cable faults, sensor faults, etc.

You can use the I/O menu on the teach pendant to check whether the current I/O board is functioning properly. Refer to Chapter 11 - Inputs & Outputs for procedure.

If **replaced**, there are no adjustments or procedures required.

2.4.7 Combined I/O Board DSQC 315

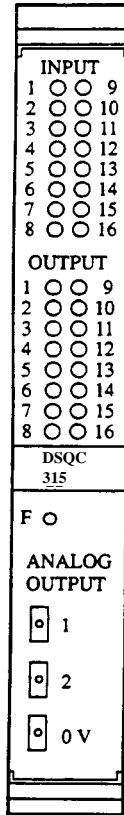

<u>Designation</u>	<u>Color</u>	<u>Description</u>
INPUT	Yellow	See digital I/O board (p 2-17).
OUTPUT	Yellow	See digital I/O board (p 2-17).
F	Red	Turns off when the board approves the initialization.
1	Measuring	CH1, 0 - +10V terminal
2	Measuring	CH2, 0 - +10V terminal
0V	Measuring	0V

The combined I/O, DSQC 315, is equipped with 16 digital inputs, 16 digital outputs (see DSQC 223, page 2-17) and 2 analog outputs 1-10V (see DSQC 209, page 2-19). See digital I/O and analog I/O specification and tips. Refer to Chapter 11 - Inputs & Outputs for procedure.

If **replaced**, there are no adjustments or procedures required.

2.4.8 Analog I/O Board DSQC 209

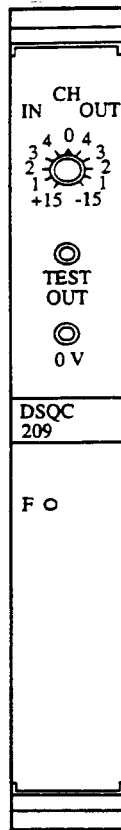

<u>Designation</u>	<u>Label</u>	<u>Description</u>
Test switch	+15:	+ supply
	IN 1-4:	input signal
	0:	0V
	OUT 1-4:	output signal
	- 15:	- supply
Test out	Measuring terminal	The analog value of the signal indicated by the test switch.
0V	Measuring terminal	0V
F	Red	Turns off when the board approves the initialization.

The analog I/O board, DSQC 209, converts analog input signals to digital and vice versa. The signal level equals 10V in and out with a resolution of 12 bits including characters. The board is supplied with $\pm 15V$, either internally or externally. The analog side of the board is galvanically insulated from the system. The first output, is the current output, which can drive or sink a current of 20 mA. The board has a test input/output on the front panel and a test switch which can be used to test whether the board is working properly. By turning the test switch to the position for measuring inputs, a power supply can be connected to the test terminal (protecting resistance should be used in the serial channel) to test whether the inputs are working properly.

If **replaced**, there are no adjustments or procedures required.

The I/O window can be used to check the status of the inputs and outputs. Outputs can be controlled manually and inputs can be read from the I/O window. Common causes of errors are cable faults or faults in external equipment. If none of the channels work, check that the internal or external $\pm 15V$ supply is OK and correctly connected. If the red F-LED is lit, the board is probably faulty or the system parameters are incorrect (i.e. the board is not defined). Refer to Chapter 11 - Inputs & Outputs for procedure.

2.4.9 Remote I/O Board DSQC 239

Symptom Description

Source of Fault

A: 32 yellow LEDs indicate the status for the first 16 inputs and 16 outputs.

Robot computer board, rear plane, internal fault in the unit, cabling, or system parameters.

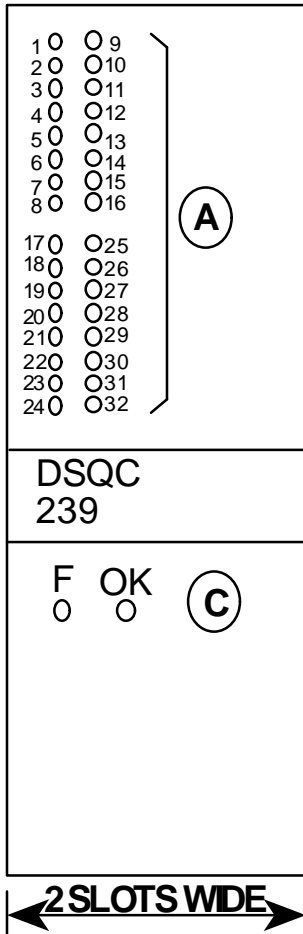

LEDs

RED GREEN		
F ACTIVE (OK)		
OFF	ON	Normal indication, Node Adapter fully operational
ON	ON/OFF	Node adapter board not properly initiated, probable cause: - Board faulty - Incorrect I/O-type parameter
ON/OFF	OFF	No communication with host processor, probable cause: - Incorrect parameters for RIO-board - Incorrect wiring - Host processor fault
ON/OFF	BLINK	Bad Communication, probable cause: - Host Processor in Program mode - Reversed connections

The serial I/O interface, DSQC 239 (RIO), is intended to be used for communication with Allen-Bradley PLC equipment. The board is equipped with 32 yellow LEDs (which indicate the status of the first 16 inputs and outputs on the front panel), a red F-LED and a green LED, "ACTIVE".

If the green LED is not lit and the red one goes OFF, the board's special communication circuit is probably faulty.

If **replaced**, there are no adjustments or procedures required.

2.4.10 Axis Board DSQC 233

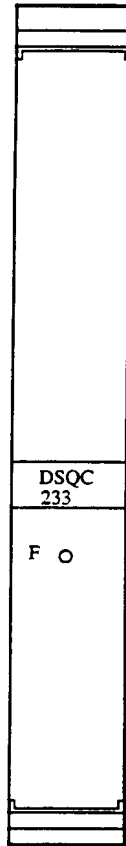

<u>Designation</u>	<u>Color</u>	<u>Description</u>
F	Red	Turns off when the board approves the initialization.
Inputs (SYNC)		Low -21V to +2V High +19V to +35V

DSQC 233 is intended for use as an axis board for ABB and customer-specific external axes. The board is controlled by the axis computer via a serial bus on the backplane and can handle six axes.

Connections:

- Resolvers and tachometers
- Resolver supply with programmable offset
- Optically-insulated sync. inputs
- References to number of revolutions

The board is equipped with a red F-LED on its front, lit by the axis computer whenever there is an error.

2.5 Serial Measurement Board (SMB)

Fig. 2-3 ➡

The SMB is located in the robot. The SMB does not have any LEDs located on it.

The SMB reads the resolvers feedback and converts the analog voltage into a digital signal. Then the SMB converts the digital signal into a serial communication. The position of all six (6) axes resolvers are communicated to the robot computer every .5msec.

Sheet 13.1, line 01..... ✎

The SMB can be checked most thoroughly with an Oscilloscope. The signals to check for are the Serial Data Out (SDO) and the Serial Data In (SDI). Another signal to check would be the exciter signal going to the resolvers. Use the Oscilloscope to check for proper amplitudes and ensure that there is no noise on these lines.

If the SMB is **replaced**, the resolver revolution counts will have to be updated. Refer to Chapter 10 - Calibration Procedures for the proper procedure.

TESTPOINTS

Test Connector 1

1	0V	EXC1	2	EXC1
3	Y1		4	X1
5	Y2		6	X2
7	Y3		8	X3

Test Connector 2

1	0V	EXC2	2	EXC2
3	Y4		4	X4
5	Y5		6	X5
7	Y6		8	X6

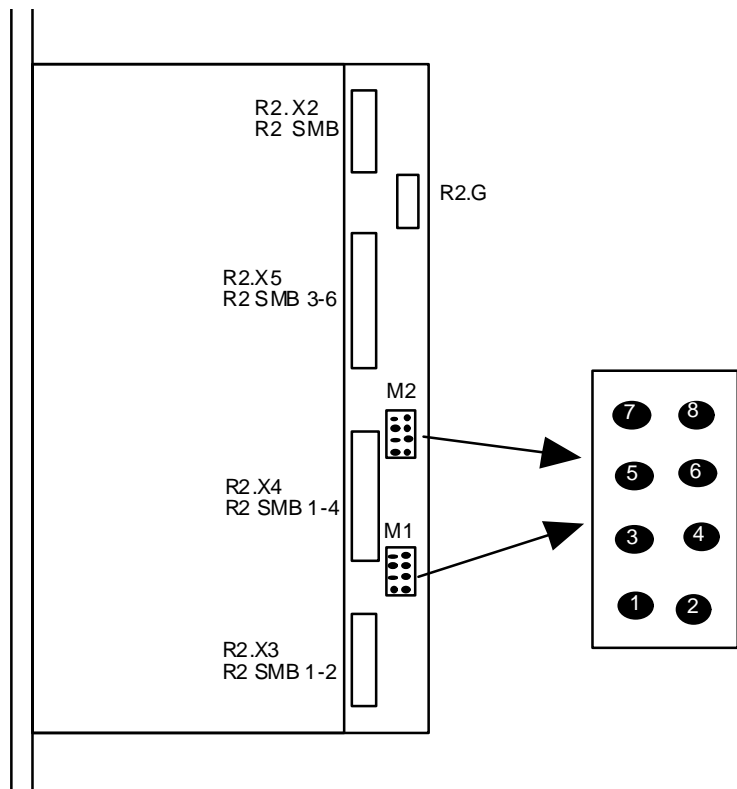

2.6 Teach Pendant

Sheet 7, line 01 

Sheet 8, line 01 

The Teach Pendant communicates with the robot computer via a cable (XS20). This cable is also used for the +24V supply and the dual operation chain. The unit's communication signals are fuse-protected on the backplane (F1 and F2). These are PTC type fuses that automatically reset when the short has been corrected.

An error in the teach pendant may mean that the rest of the system cannot be used. If the teach pendant seems to be completely dead, but the rest of the system is working correctly, the Teach Pendant may have failed, or a cable break may have occurred.

Communication errors between the teach pendant and the I/O computer are indicated by error messages on the teach pendant and also when the red LED on the robot computer lights up.

Fig. 2-4 

The backplane has test points for the teach pendant signals, X32 TEACH PENDANT.

If **replaced**, there are no adjustments or procedures required.

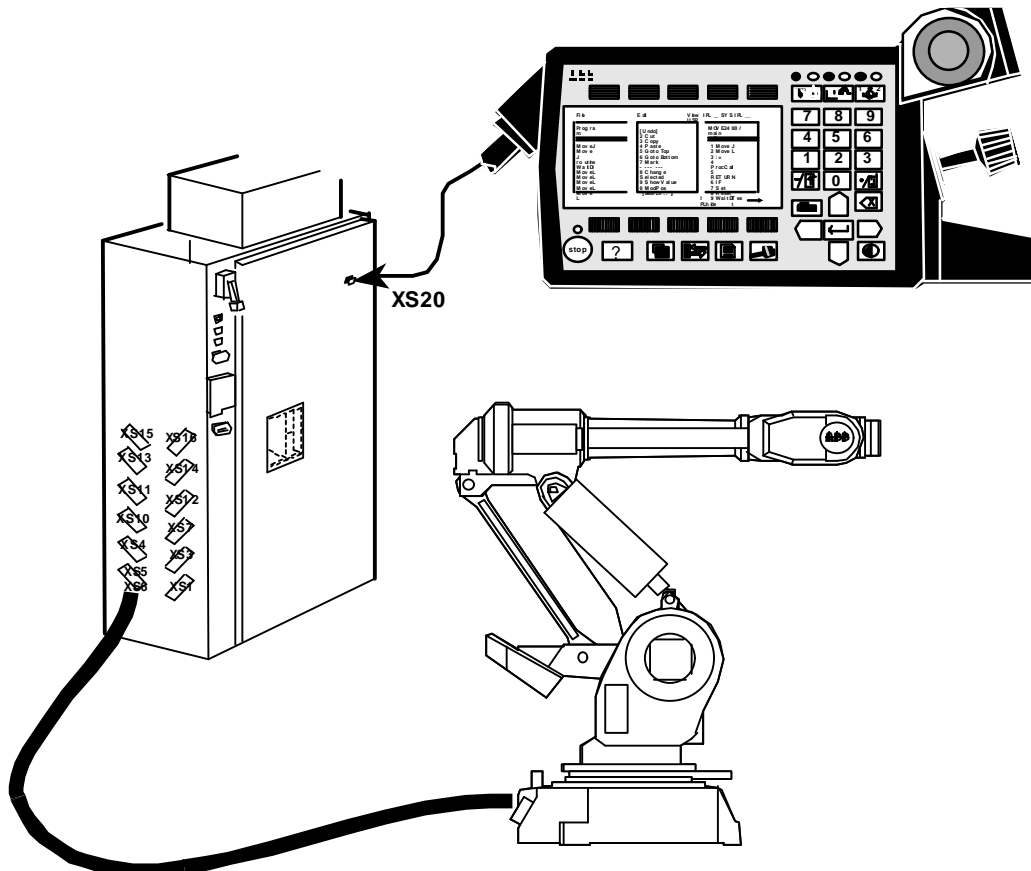

2.7 Component Cross Reference

Component Name	Component Location	Circuit Diagram Number	Location Figure
Computer system	Swing gate, bottom		2-1
Power supply	Computer system, left	Sheet 6	2-4
System Board	Computer system, center	Sheet 7, 8, 13.1	2-4
Robot Computer	Computer system, center		2-4
Main Computer	Computer system, right		2-4
Memory Board	Computer system, right		2-4
2.6 volt Batteries	Computer system, right	Sheet 14	2-4
I/O boards	Computer system, center	Sheet 18-23	2-4
PWM drive	Swing gate, top	Sheet 12	2-4
Serial measurement board	Robot, front	Sheet 13.1, 104	2-3
Teach pendant	Cabinet, front	Sheet 7, 8	2-5
Wrist strap	Swing gate, front		2-1
Digital I/O board DSQC 223	Computer system, center	Sheet 19.1, 20.1	2-4
Combi I/O board	Computer system, center	Sheet 19.1, 20.1, 21.1	2-4
Analog I/O board	Computer system, center	Sheet 22	2-4
Remote I/O board	Computer system, center	Sheet 23	2-4
EPROM chips	Robot computer board		2-1
XS3.XT3	Cabinet, back	Sheet 6, 7, 8	2-2
GS1	Computer system, back	Sheet 6	2-2

2.8 List of Circuit Diagrams

1.	POWER SUPPLY, +24VDC, +5VDC	6 of 43
2.	MOTOR ON CHAIN PART 1	7 of 43
3.	MOTOR ON CHAIN PART 2	8 of 43
4.	CONTROL CABLE	13.1 of 43
5.	I/O BOARD POSITION	18 of 43
6.	DIGITAL I/O BD., COMBI, I/P PART	19.1 of 43
7.	RELAY UNIT, I/P 1-16	19.2 of 43
8.	120VAC INPUT	19.3 of 43
9.	DIG. PART OF COMBI I/O, I/P PART	19.4 of 43
10.	DIGITAL I/O BOARD, INPUT PART	19.5 of 43
11.	DIG. COMBI, DIG. I/O BD. O/P PART	20.1 of 43
12.	RELAY UNIT, OUTPUT 1-8	20.2 of 43
13.	RELAY UNIT, OUTPUT 9-16	20.3 of 43
14.	120VAC OUTPUT	20.4 of 43
15.	DIG. PART OF COMBI I/O, O/P PART	20.5 of 43
16.	DIGITAL I/O BOARD, OUTPUT PART	20.6 of 43
17.	COMBI I/O BD. ANALOG, O/P PART	21.1 of 43
18.	COMBI I/O BD. ANALOG, O/P PART	21.2 of 43
19.	ANALOG I/O BOARD	22 of 43
20.	REMOTE I/O BOARD FOR A-B PLC	23 of 43

NOTES

Figure 2-1 Control Cabinet

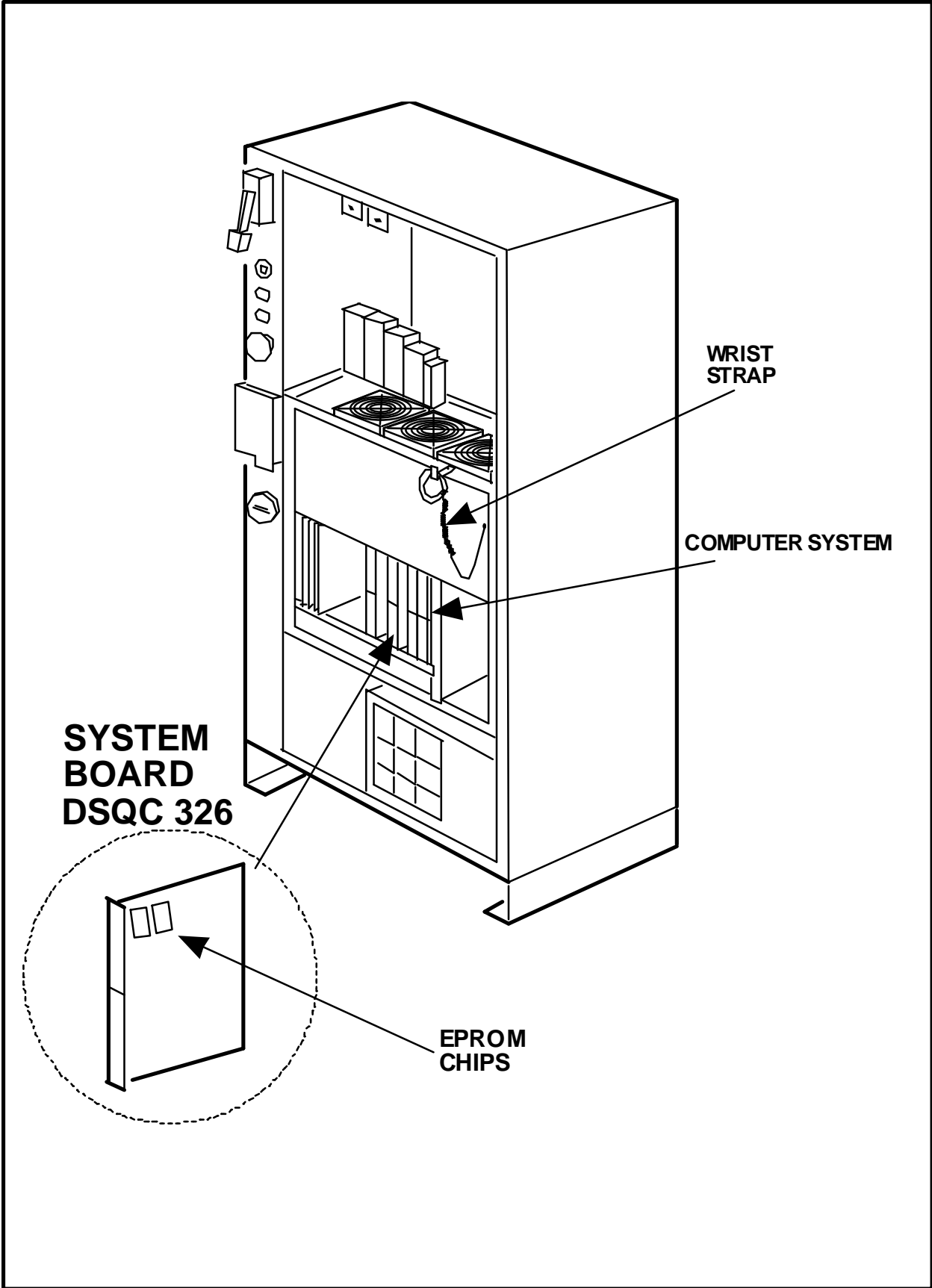

NOTES

Figure 2-2 Connectors

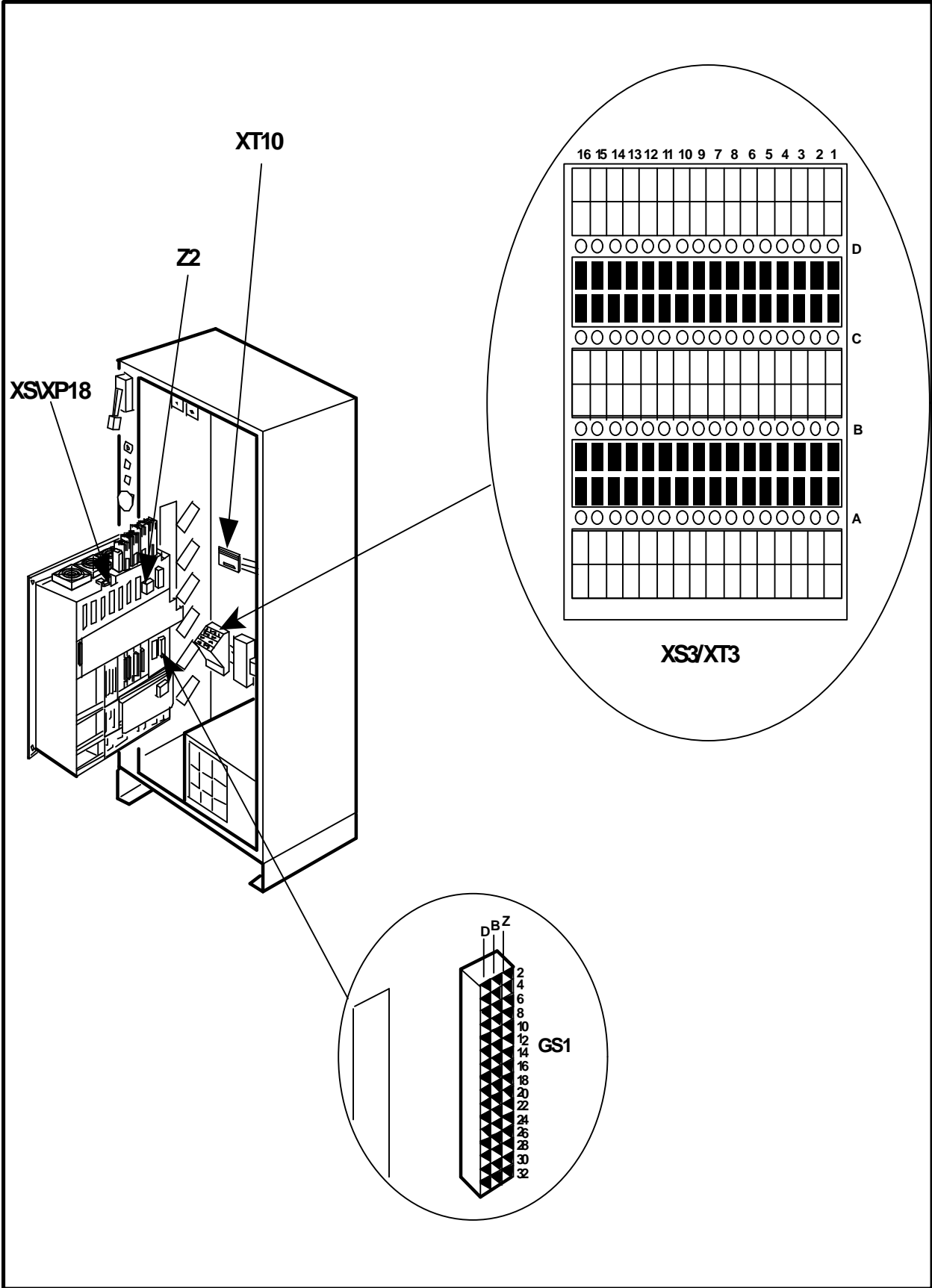

NOTES

Figure 2-3 SMB

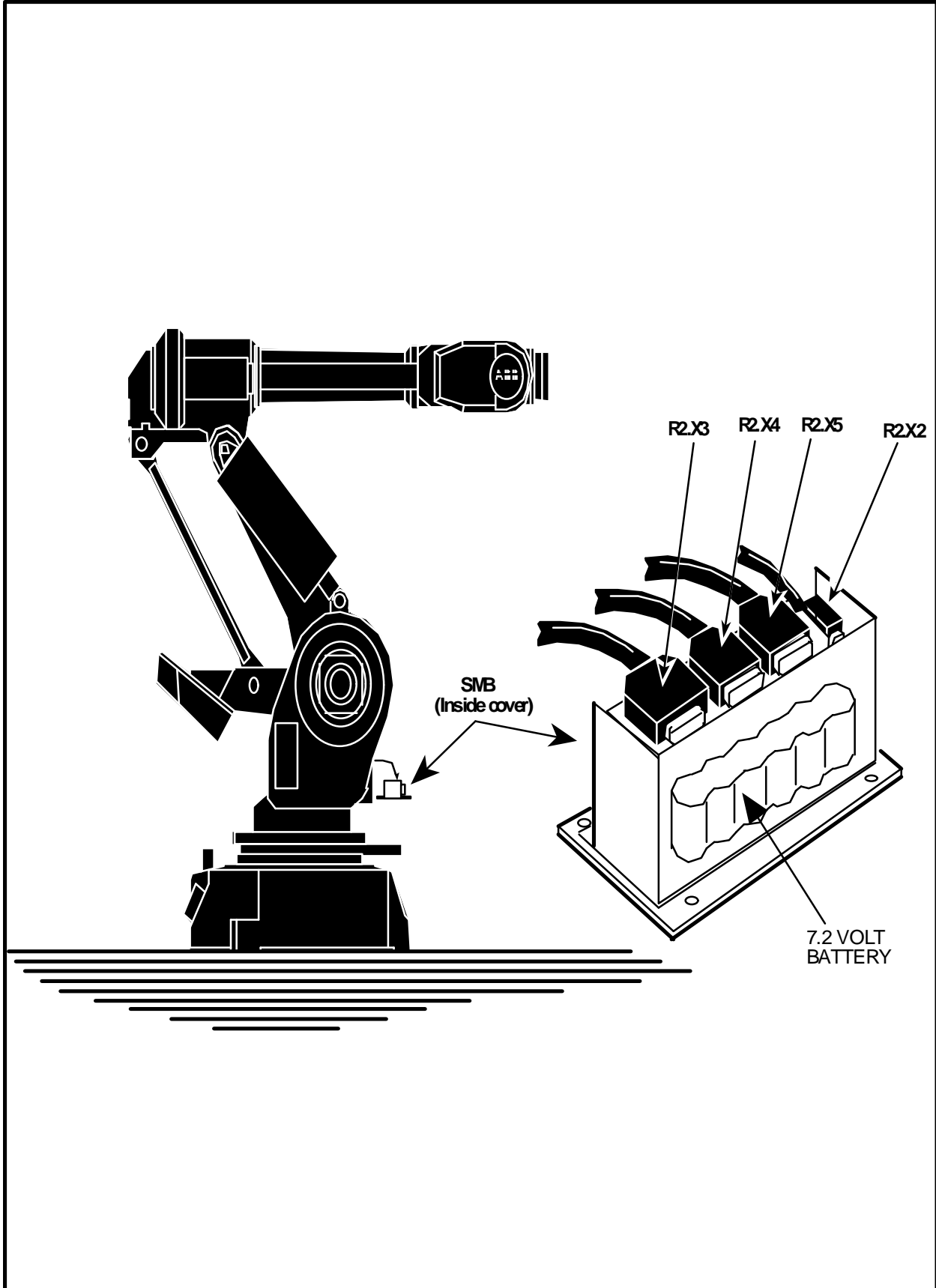

NOTES

Figure 2-4 Back Plane AP80

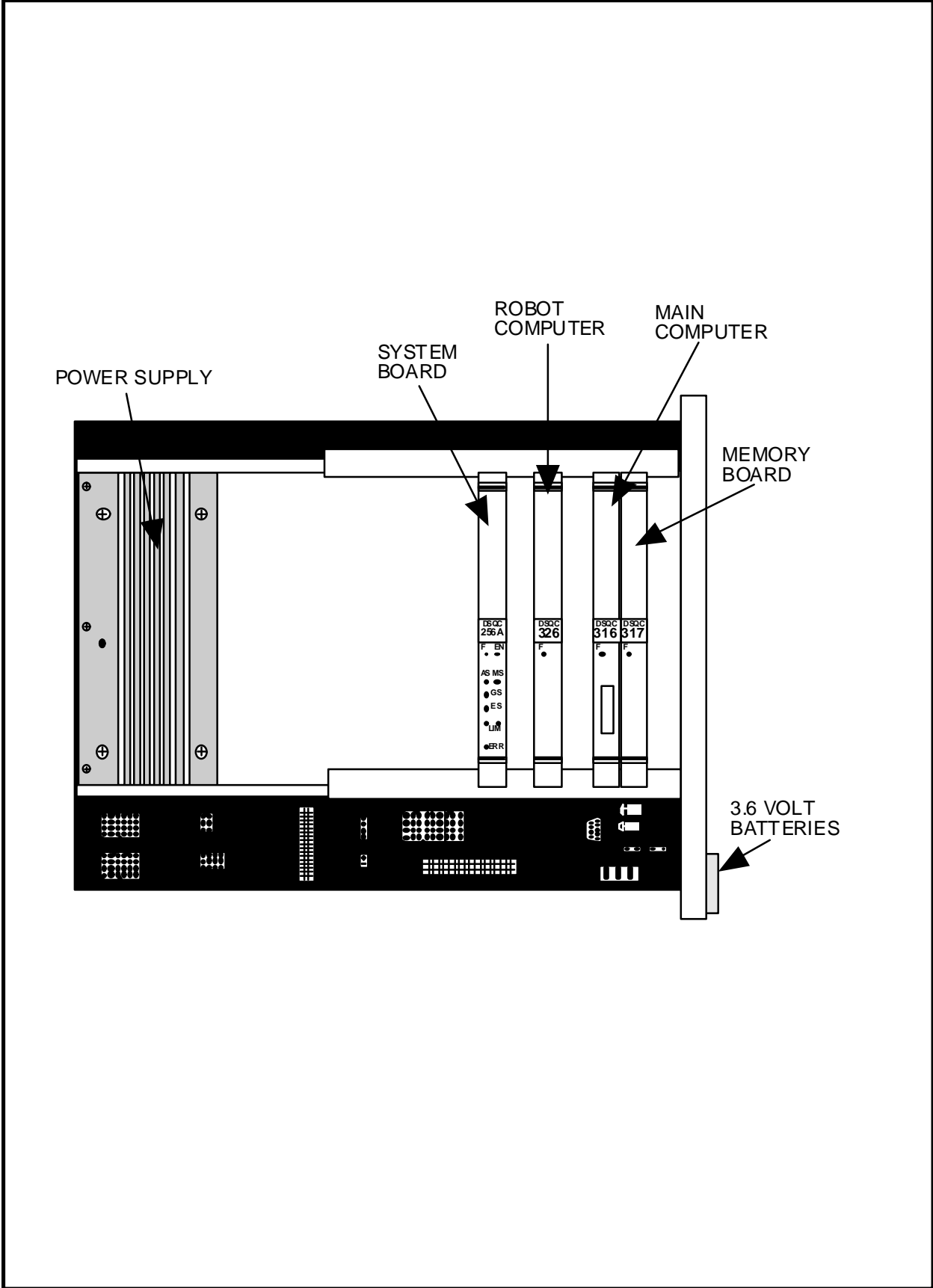

NOTES

Figure 2-5 Teach Pendant

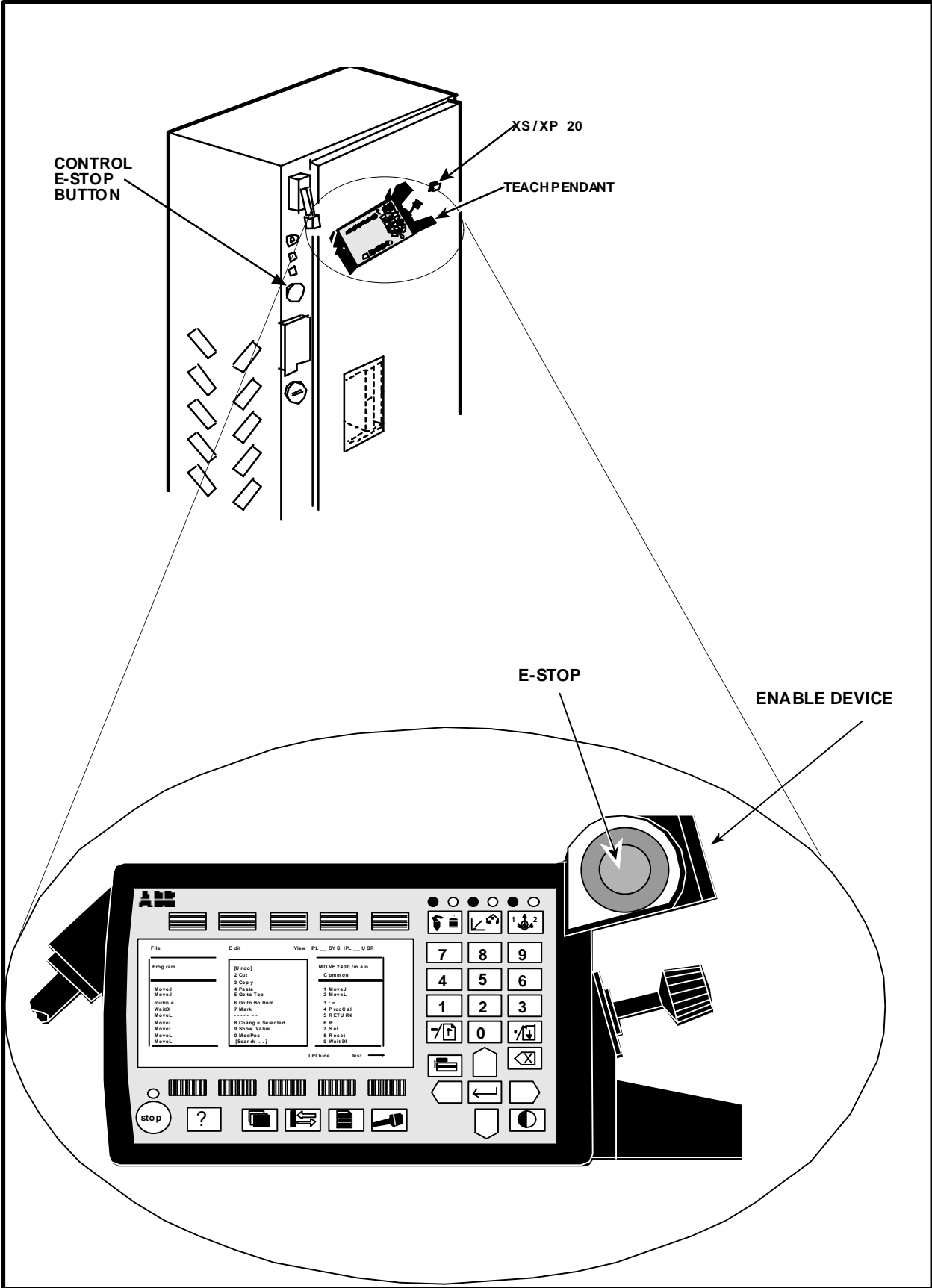

NOTES

CHAPTER 3

LOADING SYSTEM SOFTWARE

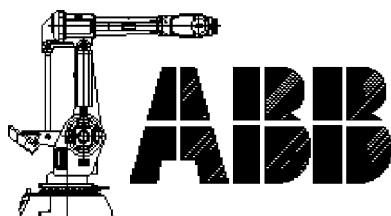

Loading System Software

Table of Contents

3.	Loading System Software.....	3-3
3.1	Overview	3-3
3.2	Floppy Disk	3-4
3.3	Software Loading Procedure	3-5
3.4	Parameter Loading Procedure	3-8
3.5	Resolver Revolution Counter Update	3-9
3.6	List of Circuit Diagrams	3-13
3.7	Component Location Figures	3-17
	Figure 3-1 Batteries	3-17
	Figure 3-2 Floppy Disk Drive.....	3-19
	Figure 3-3 Robot Calibration Position.....	3-21

NOTES



3. Loading System Software

3.1 Overview

To get the maximum flexibility out of the S4 Computer System, the operating software is loaded into RAM memory. This gives flexibility because different software options can be supplied simply by loading new system software.

The RAM memory is battery backed by two 3.6 volt lithium batteries. The life expectancy of these batteries is 5 years. If both of these batteries are disconnected *and* the main disconnect is turned off, the computer will lose the information stored in RAM. Or, if one of the computer boards (Main, Robot, or Memory) is disconnected, the system will also lose memory and have to be reloaded.

In this chapter the procedures required to reload the system software is explained.

Sheet 14, lines 11,14.... 
Fig. 3-1 

3.2 Floppy Disk

Fig. 3-2 ➔

Sheet 14, lines 13..... ✎

The S4 system uses standard 3.5" Double Sided, High Density (DS HD) disks. These disks are formatted for 1.44 MB and are IBM compatible. Notice that the disk has a metal plate on one end of the disk. This is the access cover on the disk. When inserting a disk into a disk drive make sure that the end with the access cover goes in first. The disk will only go in one way so if the disk will not go all the way in, turn it over and try again. To get a disk out of a drive, press the eject button located near the drive door.



NOTE: Never remove or insert a disk while the active light is on.

Also every disk will have two square holes on the outer corners of the disk. One indicates that the disk is a high density disk. The other is used for write protection. If the write protection window is open, than the disk can not be written to. (Can not save information to the disk). This window should be opened for all system software disks. This way the original information will stay protected.

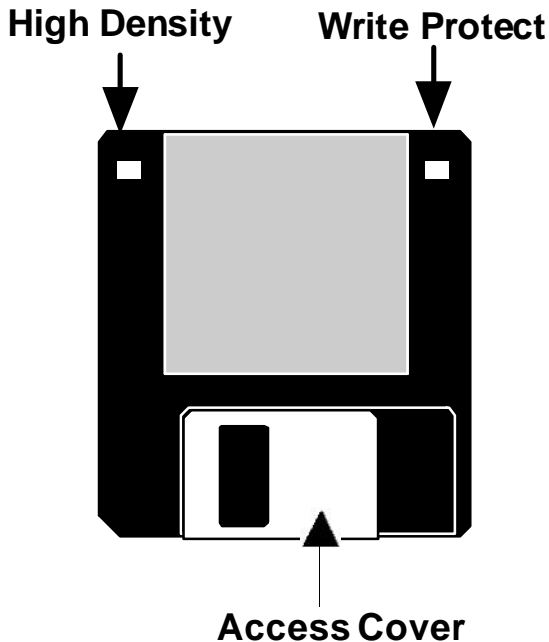

When the customer receives the system software for their system, they should make backup copies of the original disks and use the backup copies on the machines. The originals should then be put in a safe place and only used as backups. The making of the copies should be done using an IBM compatible PC. It is possible to format disks on the robot using the file manager. However, the easier way to format and copy disks, is with any IBM compatible computer with a high density disk drive.

To format a disk on the robot, insert the disk to be formatted and choose the following commands:

```
MISC  
FILE MANAGER  
OPTIONS  
FORMAT  
FLP1  
OK
```

Then the system will format the floppy disk that is in the drive. When the formatting is complete the screen will return showing the contents of the empty disk.

3.3 Software Loading Procedure

The system software for the system is contained on several disks. The following procedure explains how to load the system software into a system. When this procedure is complete, it will be necessary to load system parameters and to update the resolver counts.



Remember to only use copies of the original disk when loading the system software.

1. If the system has lost its software, a message on the display will indicate this and prompt you to insert the first Boot Disk.

Welcome to the S4 controller v1.0

The system is empty and requires installation of the controller software.

Please insert boot disk 1 and press any key to start loading.

2. Insert Boot Disk 1 (article number 3HAB2312-2.rev#). Press **ENTER** on the teach pendant. The system will begin loading information from the floppy disk.
The message "Loading....." will appear.
3. When the control prompts you to insert Boot Disk 2, wait for the disk drive active light to go out and then insert Boot Disk 2 (article number 3HAB2312-2.rev#), and press **ENTER**.
The message "Loading....." will appear.
4. When the control prompts you to insert Boot Disk 3, wait for the disk drive active light to go out and then insert Boot Disk 3 (article number 3HAB2312-2.rev#) and press **OK**.
The message "Loading....." will appear.

Software Loading Procedure (Cont)

5. When the display "Phase 1 complete" appears **DO NOT REMOVE THE DISK**. The system will continue loading. The system will then ask you some questions.

The questions are:

- a. Select IRB type to install

The choices are:

1400
2400
3400
4400 6400
SCAN 6400C

Select the appropriate one for your robot.

- b. Select the robot type.

The choices are

2.25-75 2.9-120
2.4-120 3.0-75
2.4-150
2.8-120
SCAN

- c. Select the motor type, Axis 4-6.

The choices are:

ELMO
SIEMENS

- d. Select the language you want.

Choices are:

0 English
1 Swedish
2 German
3 French
4 Spanish
etc.

Software Loading Procedure (Cont)

e. **Select motion parameters.**

The choices are:

**STANDARD
SERVICE**

Use standard if the system has only 6 axes and no external axes. Use service if the system has external axes.

The control will then finish booting from Disk 3.

6. When the control prompts you to insert the IRB Disk (also known as Elmo/Siemens disk), wait for the disk drive active light to go out. Then insert IRB Boot Disk (article number 3HAB2314-1.rev# or 3HAB2315-1/rev#). Press **OK**.

7. When the control is finished with the IRB Disk it will ask you:

"Any optional disks to install?"

If you have any of the following:

Advanced Functions Disk (program number 3HAB2304-2/rev#),
RAP Serial Link (program # 3HAB2308-1/rev #),
Arcware M94A (program # 3HAB2309-1/rev #),
Spotware M94A (program # 3HAB23XX-X/rev #).

Insert the disk(s) one at a time and press **YES**.
Keep loading any other optional disks until you are finished with your options.

When you have finished loading the optional disks or if you have no optional disks press **NO**.

The control will then restart and the software is loaded.

You may get Joint Sync errors at this point. Press **OK** and then continue.

8. You must now load the system parameters from Boot Disk 4 or load the system parameters from your personal disk on which the current parameters have been stored.

3.4 Parameter Loading Procedure

The System Parameters store the 'machine specific' information. Ensure to match Robot Serial Number with system parameters. Some examples of this information are resolver offset values, I/O configurations, and other system configuration data. The system parameters are loaded from Boot Disk 4 or loaded from your personal disk, on which the parameters had been stored previously.

1. Insert the disk into the disk drive and use the following key strokes:

```
MISC
SYSTEM PARAMETERS
FILE
LOAD SAVED PARAMETERS
```

2. Then select the desired directory that the system parameters are saved (usually `SYSPAR`) and press **OK**.
3. After loading system parameters the system must be restarted. Press:

```
FILE
RESTART
OK
```

Joint sync errors may occur. Press **OK** and continue.

4. Now the resolver counters must be updated.

3.5 Resolver Revolution Counter Update

After loading system software, the resolver counter revolutions must be updated. The robot does not know where it is and must be told by updating these counters.

Fig. 3-3 ➤

1. Move the robot to the calibration position using the joystick. Each axis may be moved and updated individually, except for Axis three. Axis three's position depends on axis two's position. Always have Axis two in position before moving axis three into position.



IMPORTANT: Axis 6 has no hard stops. This means that when a robot is not updated, axis six is allowed to rotate endlessly. However, the revolution counter will only be correct at one position and being multiple axis revolutions off won't work correctly.



NOTE: If counter values are lost the robot will not move in linear motion.

2. When the robot has been moved into the calibration position, press

MISC
SERVICE
VIEW
CALIBRATION

The following screen will be displayed.

File	Edit	View	Calib
Service Calibration			
Unit	Status	1 (1)	
IRB	Not Rev. updated		

Resolver Revolution Counter Update (Cont)

3. Press:

CALIB
REV. COUNTER UPDATE.

The following screen will be displayed.

Calibrate IRB To calibrate, include axes and press OK.		
Axis		Status
X	1	Not Calibrated
X	2	Not Calibrated
	3	Calibrated
	4	Calibrated
	5	Calibrated
	6	Calibrated
Incl	All	Cancel OK

4. Move the cursor to the desired axes to be updated and press:

INCL
or press **ALL** (to include all axes.)

The selected axes will be marked with an "X".

5. Press **OK**. A warning message will be displayed. If everything is correct then press **OK** again.

The following screen should appear:

File	Edit	View	Calib
Service Calibration			
Unit		Status	
IRB		Synchronized	1 (1)

Resolver Revolution Counter Update (Cont)

6. It is very important after completing this procedure to load and run the calibration program on the Boot Disk 4. This is done by inserting Boot Disk 4 (article number 3HAB2312-2/rev#) and pressing:

PROGRAM
FILE
OPEN

Select the directory: **SERVICE**, press **ENTER**, then **CALIBRAT**, press **ENTER**, then select the appropriate file name.

Example: For an IRB 6400 the appropriate file name is "ca16400.prg". Press **OK**. Then start the program and answer the questions for your robot. This information can be found on the tag next to the main disconnect. The questions asked will be:

- a. **Type of IRB6400.**

The choices will are

2.4-120 2.25-75
2.4-150 2.9-120
2.8-120
3.0-75
MORE

- b. **Position.**

CAL POS (Calibration Position)
DEL POS (Delivery Position)
OIL POS (Oil Drain/Fill Position)

- c. **Calibration Position.**

NORMAL
LEFT
RIGHT

Resolver Revolution Counter Update (Cont)

If the calibration marks line up after running the calibration program than the robot is ready for the application program that is loaded the same as the calibration except the directory and filename is specific for your machine.

If the Calibration marks do not line up:

- a) Retry counter updating procedure again, pay particular attention to your accuracy.
- b) Check the resolver values as compared to the written values in the base next to the Axis 1 motor. See Chapter 10 - Calibration Procedures for procedures.
- c) Re-calibrate robot. See the Calibration Chapter for procedures. If this works, note that there could be a resolver problem occurring.
- d) If problem reoccurs, troubleshoot the resolver circuits as per Chapter 9 - Motors and Resolver Circuitry.

3.6 List of Circuit Diagrams

1. FLOPPY DISC UNIT, DATA PORTS, BATTTS 14 of 43

NOTES

3.7 Component Location Figures

Figure 3-1 Batteries

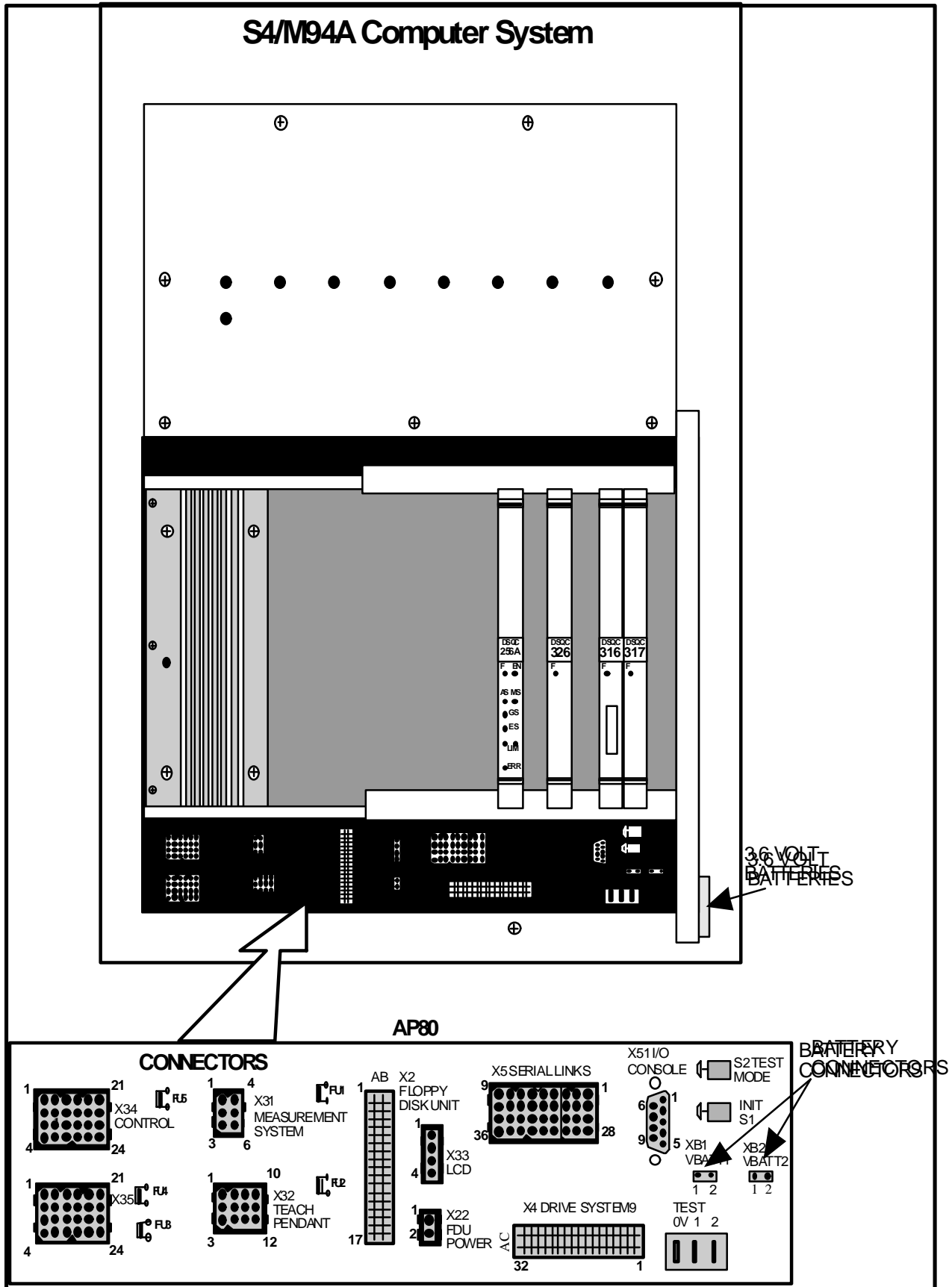

NOTES

Figure 3-2 Floppy Disk Drive

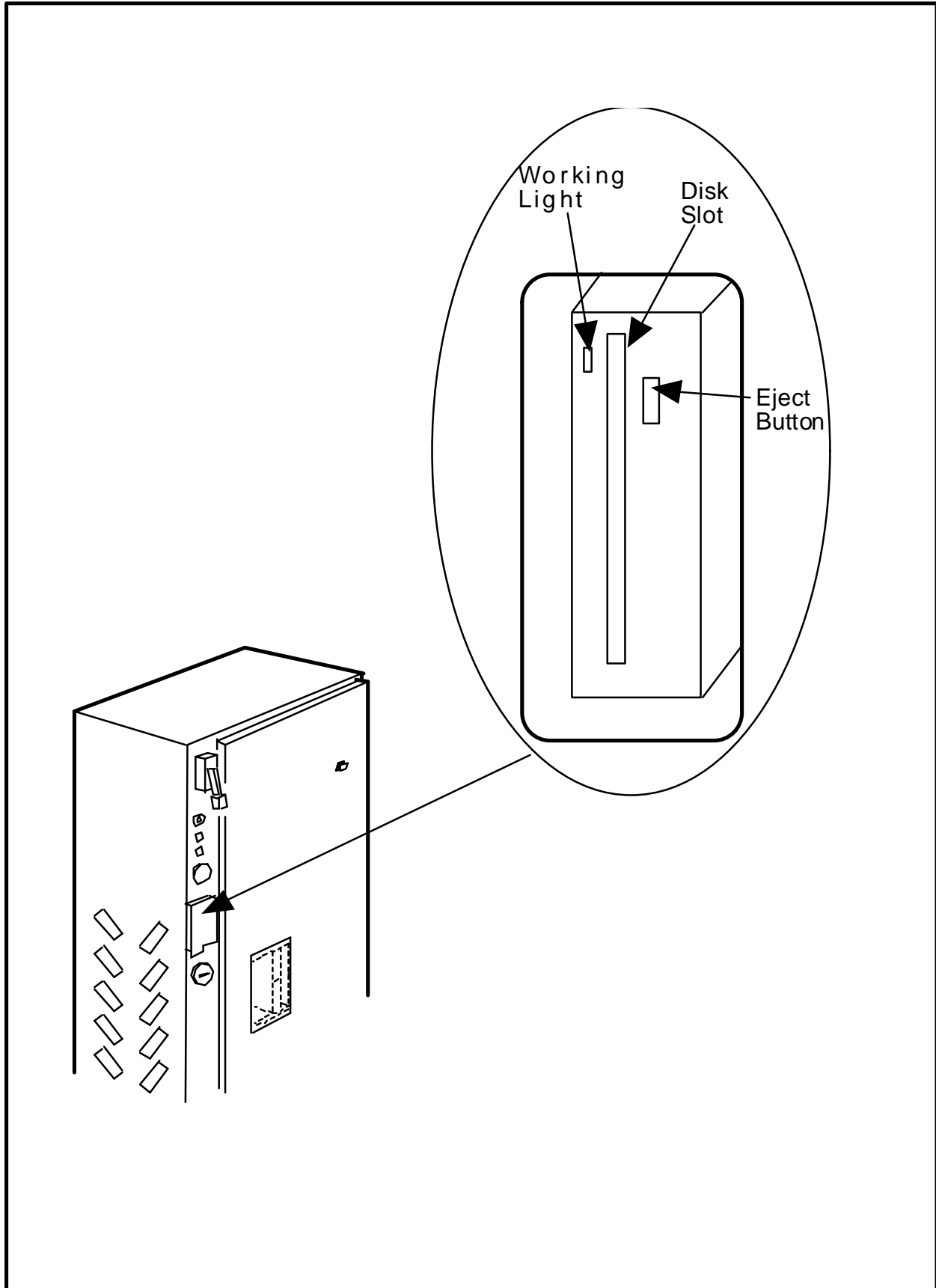

NOTES

Figure 3-3 Robot Calibration Position

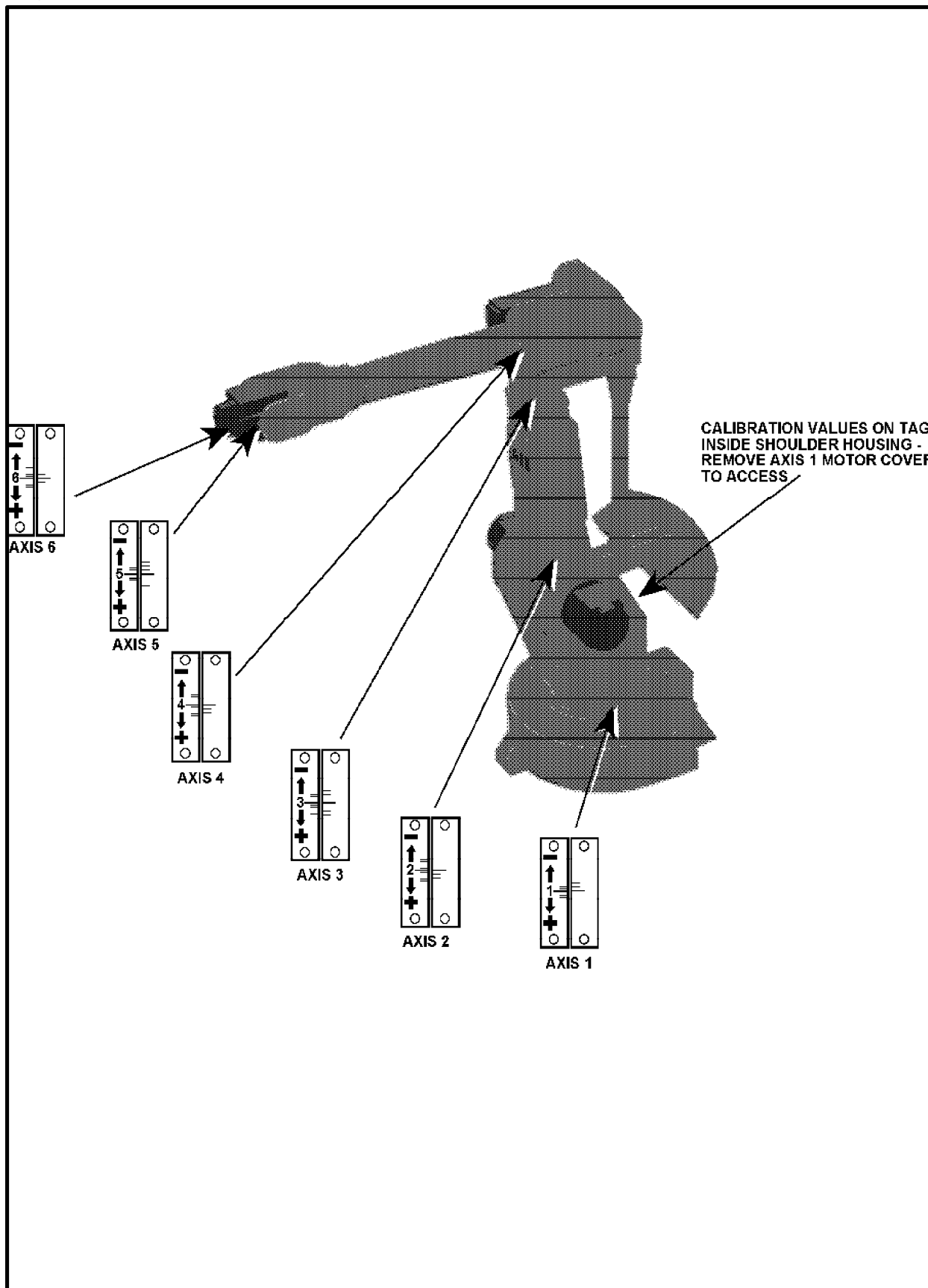

NOTES

3.7 Component Location Figures

Figure 3-1 Batteries

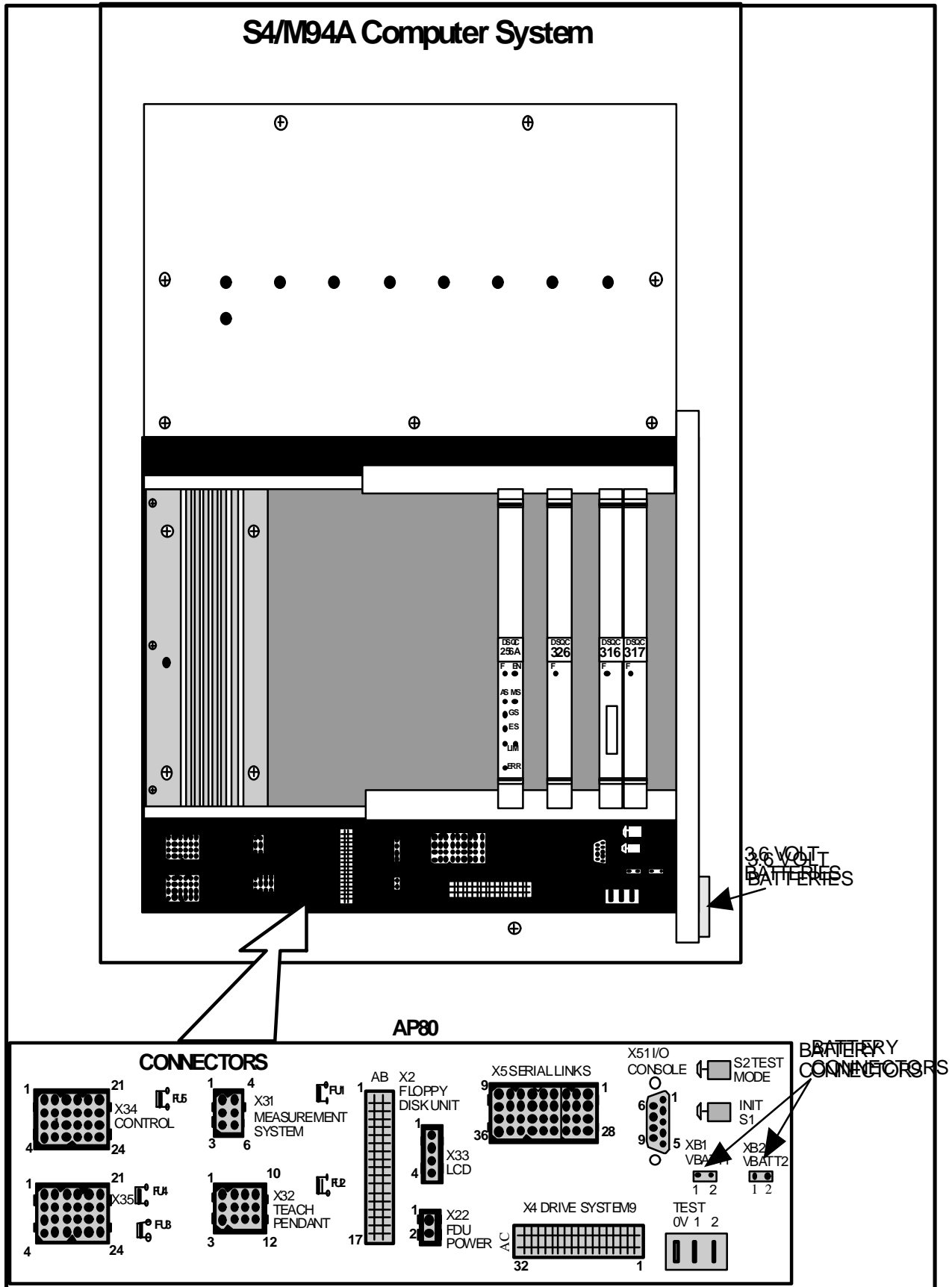

NOTES

Figure 3-2 Floppy Disk Drive

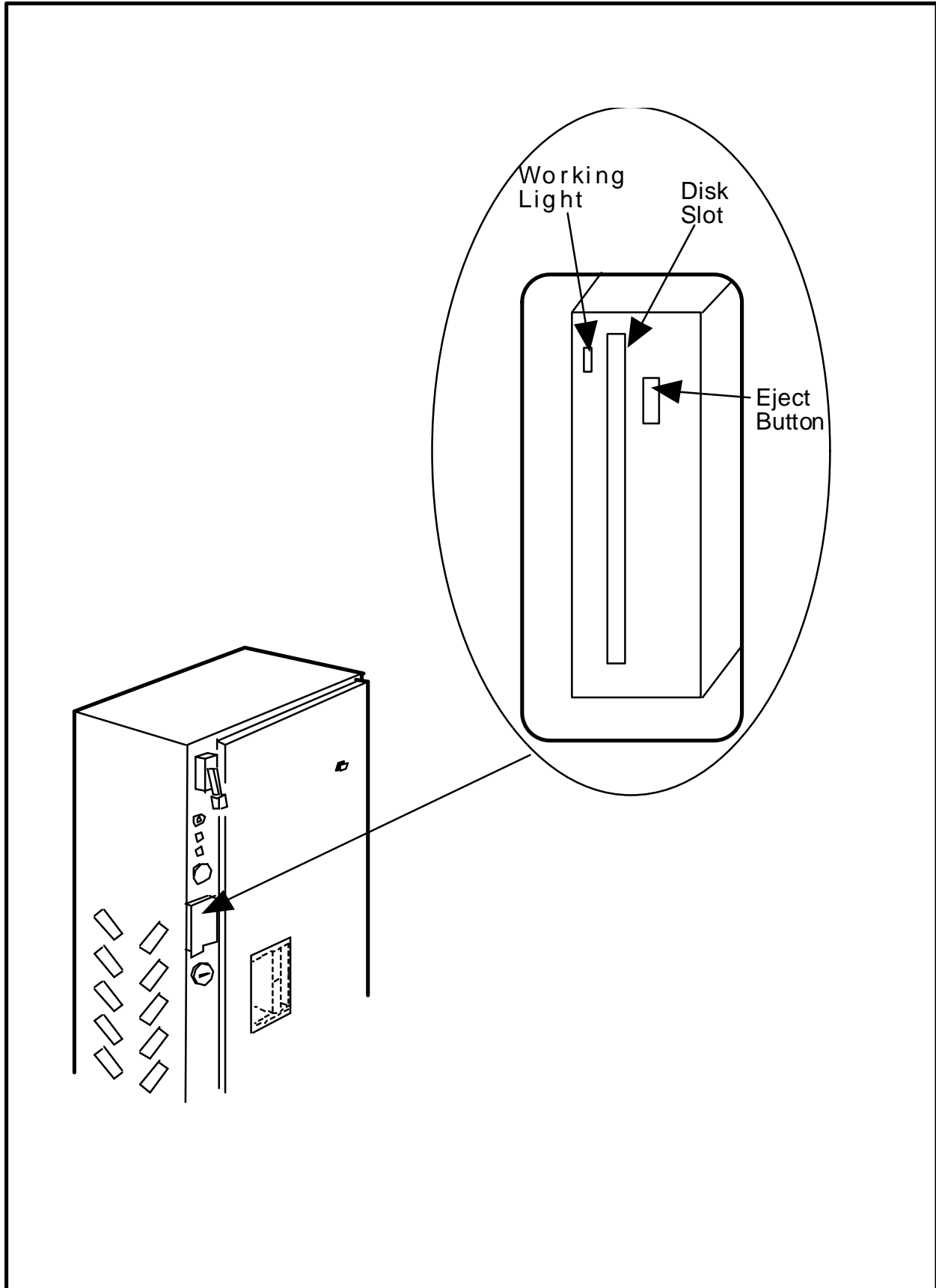

NOTES

Figure 3-3 Robot Calibration Position

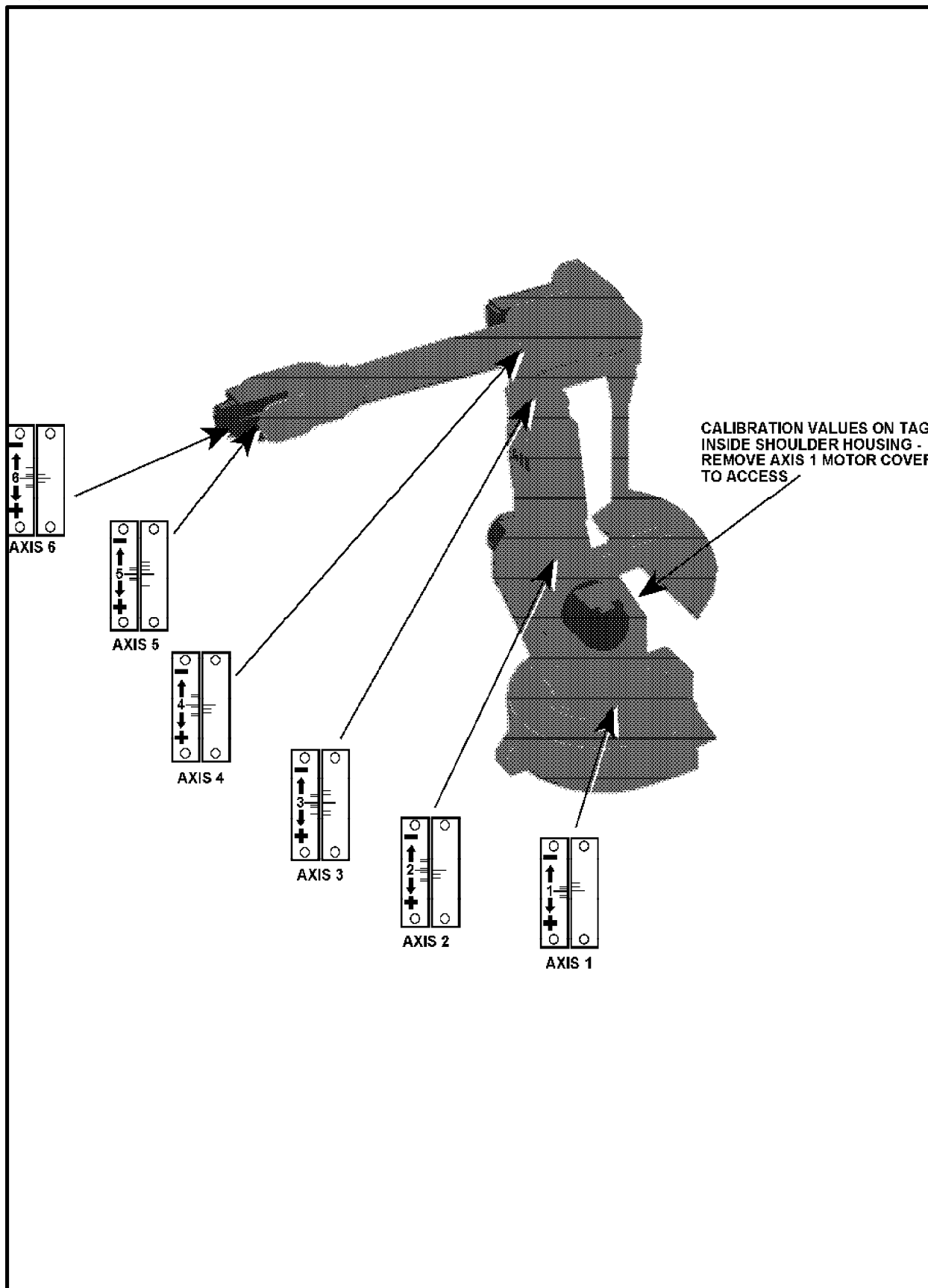

NOTES

CHAPTER 4

POWER ON CIRCUITRY



Power ON Circuitry

Table of Contents

4.	Power ON	4-3
4.1	Overview	4-3
4.2	AC Power Distribution	4-4
4.3	DC Power Distribution	4-5
4.4	Component Cross Reference	4-8
4.5	List of Circuit Diagrams	4-9
4.6	Component Location Figures	4-23
	Figure 4-1 Inside Front of Control Cabinet.....	4-23
	Figure 4-2 Inside Swing Gate.....	4-25
	Figure 4-3 Brake Push Buttons.....	4-27
	Figure 4-4 Customer Connection XS3/XT3.....	4-29
	Figure 4-5 Operator's Panel.....	4-31

NOTES

4. Power ON

4.1 Overview

This chapter describes the different circuits that become 'LIVE' when the main disconnect switch is turned ON. It will go through both the AC Power Circuits and DC Power Circuits. ABB robot product lines are designed to run on several different voltage sources.





The **Back Plane** is used for easy access to the individual circuits for testing.



Capacitors rated at 100 nanofarads are used throughout the circuits to reduce noise.

4.2 AC Power Distribution

Sheet 5, line 03 
Fig. 4-2 





The Primary Voltage is connected to QS1. QS1 is a 20 amp circuit breaker. When QS1 is turned ON by the main disconnect handle, the primary voltage goes through wires labeled T1, T2 and T3. These three wires are connected to the transformer (TM1) terminals 1, 2 and 3.

The transformer's input is configured for 480 VAC by having jumpers from terminals 1 to 25, 2 to 35, and 3 to 15. The transformer's input is configured for 600 VAC by having jumpers from terminals 1 to 28, 2 to 38, and 3 to 18.





It should be noted that all AC voltages are grounded to earth ground through terminals 70 and 72.



The output of the transformer puts out several different AC voltages. They are:

Sheet 5, line 12 
Sheet 9, line 8 
Sheet 5, line 15 
Fig. 4-1 



262 VAC is used for the Motor Drive System. It is sent out from TM1 terminals 42, 52, and 62. Into FS1 terminals 2, 4, 6 (which is a 16 amp circuit breaker.) 262 VAC then goes from FS1 terminals 1, 3, 5. To KM1 terminals 2, 4 and 6 (the MOTORS ON relay.) KM1 is also the result of Run Chain 1.

Sheet 5, line 11 
Sheet 24, line 01 
Fig. 4-1,2 

230 VAC is sent through fuse FU3 (6.3 amps) terminal 74, then to **optional** AC accessories. Examples of accessories include; going through door switch SB3 to a service light in the control cabinet, a service outlet to plug in test equipment such as meters or scopes, or through door switch SB2 to a cooling device (EV4.)



Sheet 5, line 11 
Fig. 4-1,2 

120 VAC through fuse FU2 (6.3 amps) terminal 73, which can be used for the service outlet XS21 for customer use.

Sheet 5, line 11 
Sheet 6, line 17 
Fig. 4-1,2 

230 VAC through fuse FU1 (3.15 amps) terminal 71, which on wire L33 supplies power to the Control Power Supply GS1:XP1 pin D2.

4.3 DC Power Distribution

Sheet 6, line 17 
 Fig. 4-2 



The **Control Power Supply**:

- Receives 230 VAC on pin D2 of GS1 XP1.
- Produces four DC outputs. They are +5, +15, -15, and +24 VDC. (0V (zero volts) is connected to the control's earth ground.)
- Is short circuit protected on all DC outputs.
- Has a RED LED displayed in front to indicate DC voltage faults.



Fig. 4-1 



If the RED LED is FLASHING, there is a fault on the 24 VDC, possibly a short. If the RED LED stays ON, then +5 or ±15 VDC has a fault, possibly a short. If LED is OFF then there is no fault or no power.



Sheet 6, line 17 
 Fig. 4-2 

All of the DC voltages are fed to the back plane then on to all the computer boards. When all boards receive power, they will begin self diagnostics.

Sheet 6, line 19 
 Fig. 4-2 





+5 VDC is fed to pin D32, on the back of the power supply GS1 XP1, for the optional Winchester memory. *This is a good place to check the 5 VDC.*



Sheet 14, line 14 
 Fig. 4-2 

+5 VDC is also used to power the **Floppy Disk Drive** through the Back Plane AP80:X22 pin 2.



24 VDC is used in many different areas of the control cabinet.

Sheet 6, line 00 
 Fig. 4-2,3 



24 VDC is supplied for **Customer Connections**. It goes from GS1:XP1 pin B14 on the back of the power supply. Then on to terminal block XS3/XT3, terminals A15, B15, A16, B16, and C16.

Sheet 6, line 02 
 Sheet 25, line 01 
 Fig. 4-2 

24 VDC goes to the optional 230 VAC manipulator fan contactor FC1 CR at KT1.

Sheet 6, line 03 
 Sheet 12, line 10 
 Fig. 4-2 







24 VDC also goes through door switch SB1 to the **Drive Cooling Fans**, EV1-EV7 if applicable.

Sheet 6, line 05 
 Sheet 12, line 18 
 Fig. 4-2 





24 VDC is also fed through GS1:XP1 pin D14 to supply an **Enable Signal** to the drive system AP9:XP1 pin 4. *The drive system can not be started or run without this voltage.*



DC Power Distribution (Cont)

Sheet 6, line 10 
Sheet 9, line 17 
Sheet 13.1, line 11..... 
Sheet 105, line 11..... 
Sheet 104, line 01..... 
 Fig. 4-2,3 

24 VDC, named **Brake PB**, is supplied through GS1:XP1 pin D16 to XS\XP18 pin 7 and then to terminal 51 on KM4 (these are normally closed contacts) on the brake relay. When the brakes are not being released by KM4, 24 VDC is sent out to the manual brake release push buttons on the manipulator. 24 VDC from KM4 terminal 52 goes to XS1 pin B16 to the robot connector R1.MP pin B16, then to the Brake Unit (BU) through cable R3.BU1-6 connector R3.X8 pin 5. At this point 24 VDC is supplied to all six brake release push buttons.

Sheet 9, line 16 
 Fig. 4-1 



24 VDC is supplied through GS1:XP1 pin Z18, to the **Duty Time Counter** (PT). The 24 volts is only used to supply power to the timer, not to start timing.

Sheet 9, line 04 
 Fig. 4-1 

24 VDC is also supplied to the **Power Unit**, which is the four relays on top of the swing gate. 24 VDC is supplied through a temperature switch on the transformer TM1 terminal 90 and 91 then to the coil of KM2 terminal A1. The 24 VDC will not energize the relay until the 0 VDC is intact through Run Chain 2.



If the transformer gets too hot, the switch will open, preventing KM2 from energizing.

Sheet 9, line 12 
 Fig. 4-1 



24 VDC in the **Power Unit** will also energize KM3 (the supervisory relay), by going through normally closed contacts of KM1 and KM2 terminals 12 and 11. Then to the System board (DSQC 256A) as MOFF (motors OFF signal to the computer.)

Beside going to the System board (DSQC 256A), 24 VDC goes through KM4 terminals 22 and 21 (which are normally closed contacts) to XS3/XT3 terminal C1. At this point the customer may wire contacts between C1 and C2 as a 'motors hold off' circuit.





If 'motors hold off' circuit is not used, a jumper must be used between terminals C1 and C2.

From there, 24 VDC is sent to the coil of the KM3 relay. As long as XS3/XT3 terminals D1 to D2 is closed, KM3 will energize. KM3 will then latch closed through KM1 and KM2 terminal 22 and 21 and through KM3 terminals 13 and 14. 0 VDC (zero volts) is also latched through contacts KM3 terminals 53 and 54.



Sheet 7, line 01 
 Fig. 4-2 

24 VDC is fed to the **Teach Pendant** through the back plane X32 pin 5 to XS20 pin G in to the Teach Pendant. This is the only power source for the Teach Pendant.

DC Power Distribution (Cont)



Sheet 13.1, line 01..... 
 Sheet 104, line 18..... 
 Fig. 4-2,3 

24 VDC is also fed to the **Manipulator's SMB** (Serial Measurement Board) through the back plane X31 pin 3. Then to XS2 pins 'F' and 'H' and then to R1:SMB pins 'F' and 'H'. Then to R2:SMB pin 7. The 24 VDC energizes the SMB board, and charges a 7.2 volt battery on the SMB.

Sheet 8, line 03 
 Fig. 4-2 



24 VDC is used if External Axes (axis 8-12) are present to indicate that the external rectifier is working correctly. If no external rectifiers are present, a jumper is required between XS3/XT3 terminal C16 to C12.

Sheet 7, line 14 
 Fig. 4-5 

24 VDC is fed to the Key Switch through the back plane X34 pin 24 to the Key Switch Terminal 13. From there, depending on the mode selected, power will route in order:

Component	Manual Reduced	Manual Full	AUTO
Key Switch Term.	16	18	14
X34 Back Plane	19	20	18
X35 Back Plane	18	17	19
AP41:XP1	C12	C11	C10

This will identify to the computer which mode has been selected using the Key Switch.

4.4 Component Cross Reference

Component Name	Component Location	Circuit Diagram Number	Location Figure
Brake cable R3.BU1-6 and connector R3.X8	Manipulator, right	Sheet 104	4-3
Brake relay KM4	Swing gate, top	Sheet 9	4-2
Brake unit BU and push buttons	Manipulator, right	Sheet 104	4-3
Circuit breaker FS1	Cabinet, right	Sheet 5	4-1
Connector XS/XP18	Swing gate, top	Sheet 9	4-2
Control to Manipulator motor power cable R1.MP	Manipulator, back	Sheet 105	4-3
Control to Manipulator motor power cable XS1	Cabinet, left	Sheet 13.1	4-2
Cooling device EV4	Cabinet, top	Sheet 24	4-2
Customer connectionsXS/XT3	Cabinet, back	Sheet 6	4-4
Door switch SB1	Swing gate, front	Sheet 12	4-2
Door switch SB2	Cabinet, top	Sheet 24	4-2
Door switch SB3	Cabinet, top	Sheet 24	4-2
Duty time counter PT	Cabinet, front	Sheet 9	4-1
Fans EV1, EV2, EV3, EV7	Swing gate, top	Sheet 12	4-2
Fans EV5	Cabinet, Floor	Sheet 12	4-1
Fuse 3.15 amp. FU1	Cabinet, right	Sheet 5	4-1
Fuse 6.3 amp FU2	Cabinet, right	Sheet 5	4-1
Fuse 6.3 amp. FU3	Cabinet, right	Sheet 5	4-1
Main disconnect QS1	Cabinet, back	Sheet 5	4-2
Manipulator fan KT1	Cabinet, back	Sheet 25	4-2
Mode Select Key Switch	Cabinet, front	Sheet 7	4-5
Power supply GS1	Swing gate, front	Sheet 6	4-2
Power unit	Swing gate, top	Sheet 9	4-2
Run chain 1 relay KM1	Swing Gate, top	Sheet 9	4-2
Run chain 2 relay KM2	Swing gate, top	Sheet 9	4-2
Service light	Cabinet, top	Sheet 24	4-2
Service outlet XS21	Cabinet, back	Sheet 24	4-2
Supervisory relay KM3	Swing gate, top	Sheet 9	4-2
System board AP41	Swing gate, front	Sheet 8	4-2

4.5 List of Circuit Diagrams

1. MAINS DISCONNECT 5 of 43

2. POWER SUPPLY, +24VDC, +5VDC 6 of 43

3. MOTOR ON CHAIN PART 1 7 of 43

4. MOTOR ON CHAIN PART 2 8 of 43

5. POWER UNIT 9 of 43

6. 6400 DRIVE SYSTEM 12 of 43

7. CONTROL CABLE 13.1 of 43

8. FLOPPY DISK UNIT, DATA PORTS, BATTTS 14 of 43

9. COOLING, SERV OUTLET 24 of 43

10. BRAKE UNIT, SERIAL MEAS. BOARD 104 of 12

11. AXIS 1 105 of 12

NOTES

Figure 4-1 Inside Front of Control Cabinet

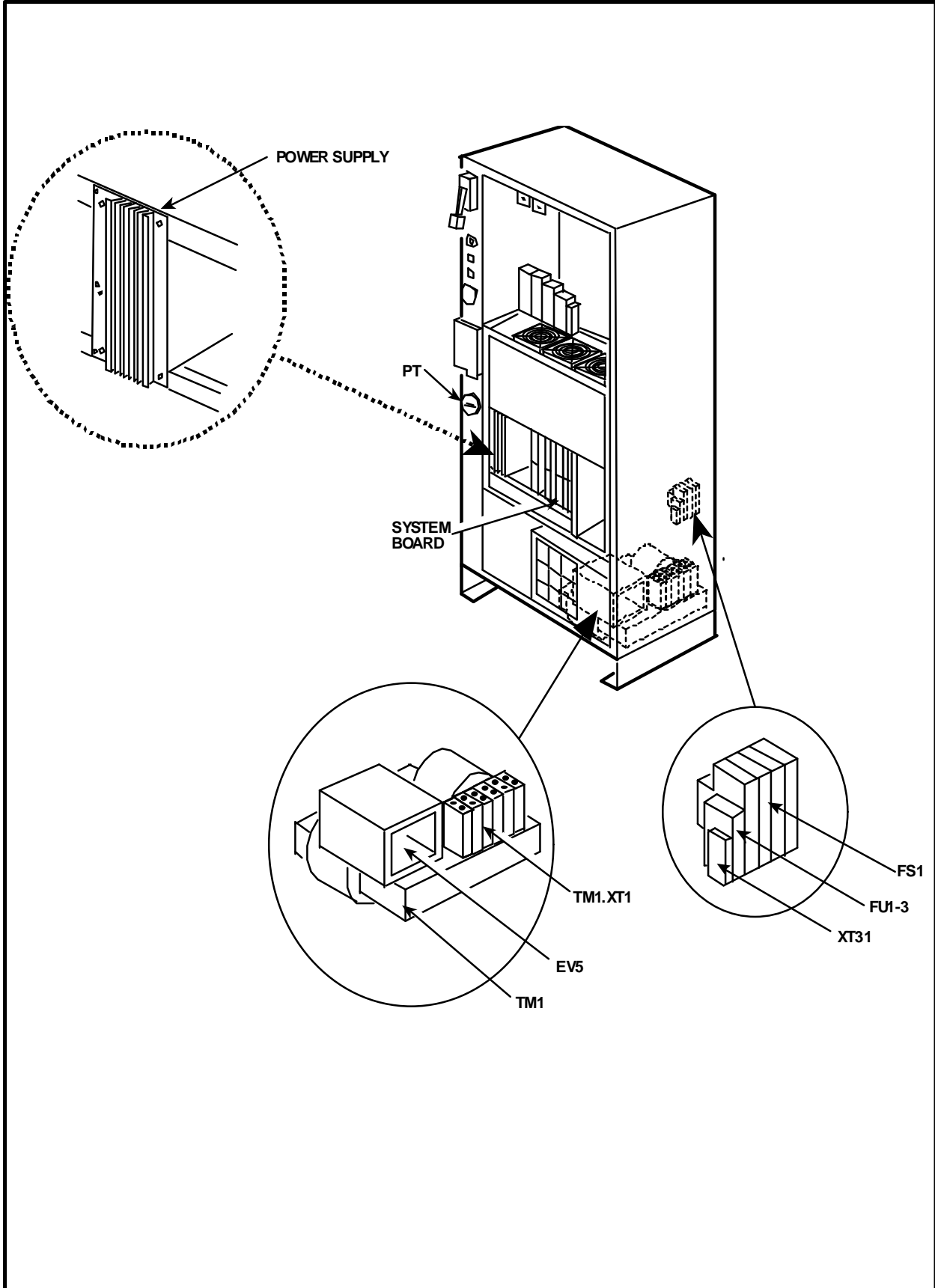

NOTES

Figure 4-2 Inside Swing Gate

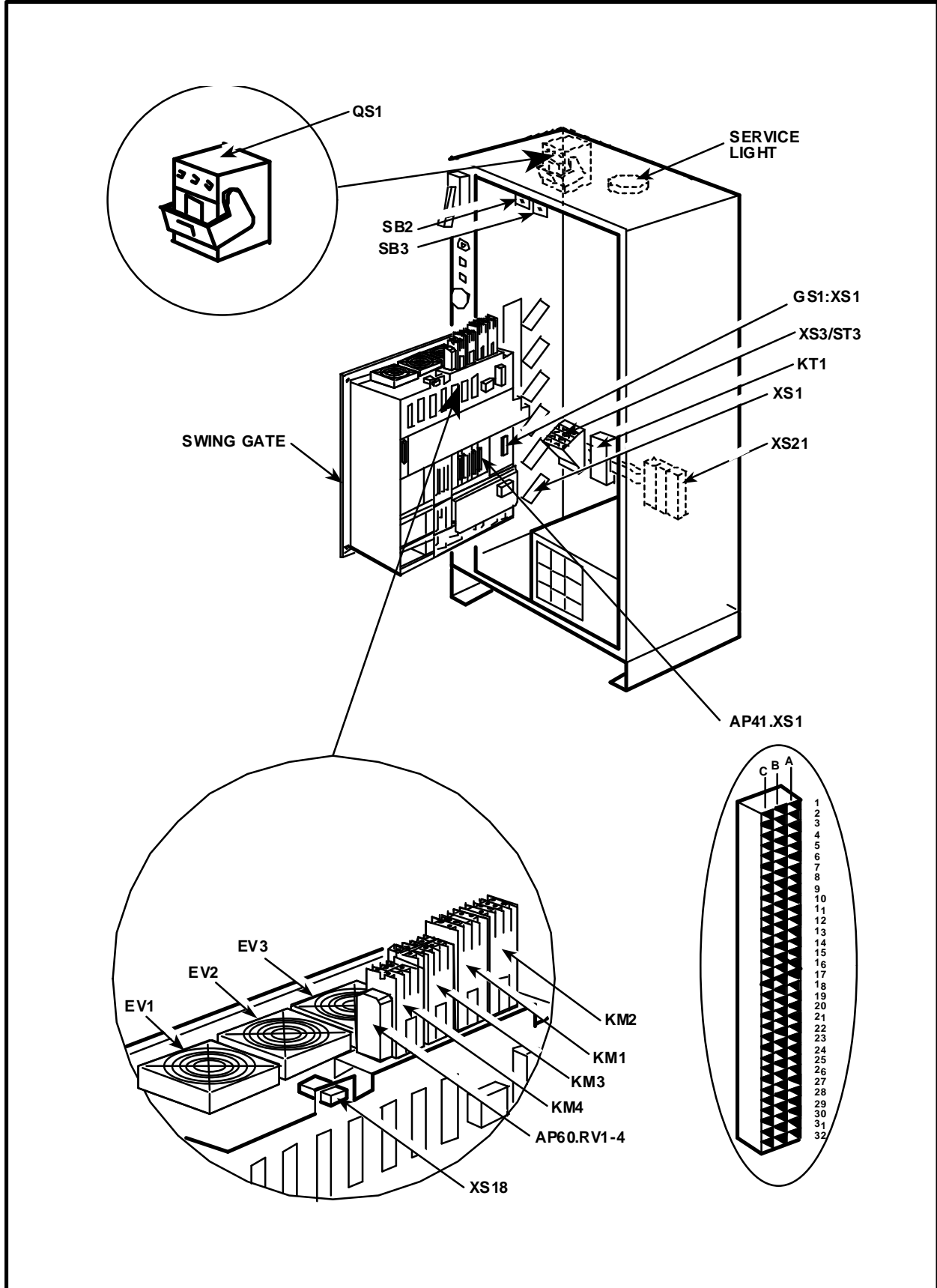

NOTES

Figure 4-3 Brake Push Buttons

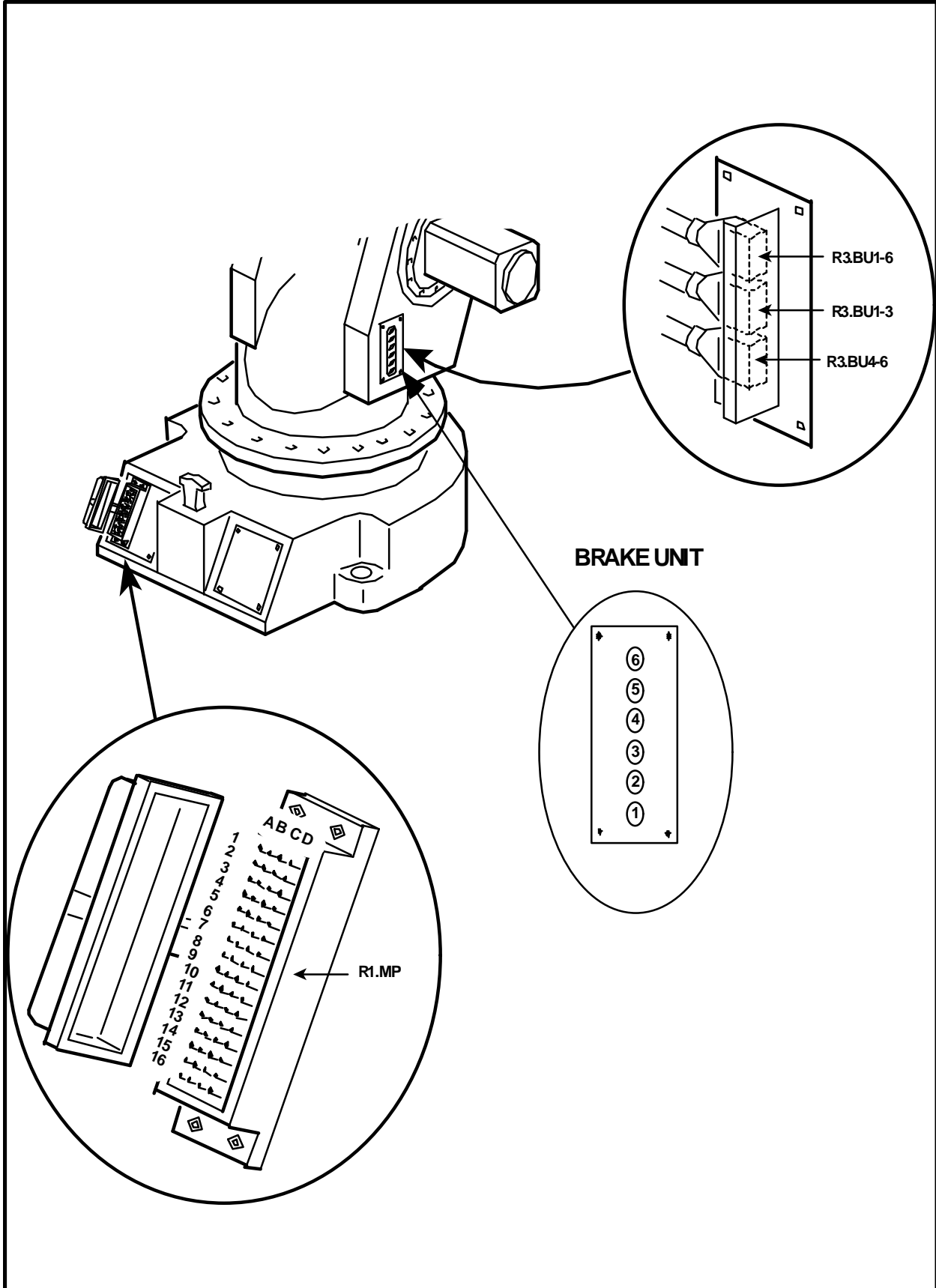

NOTES

Figure 4-4 Customer Connection XS3/XT3

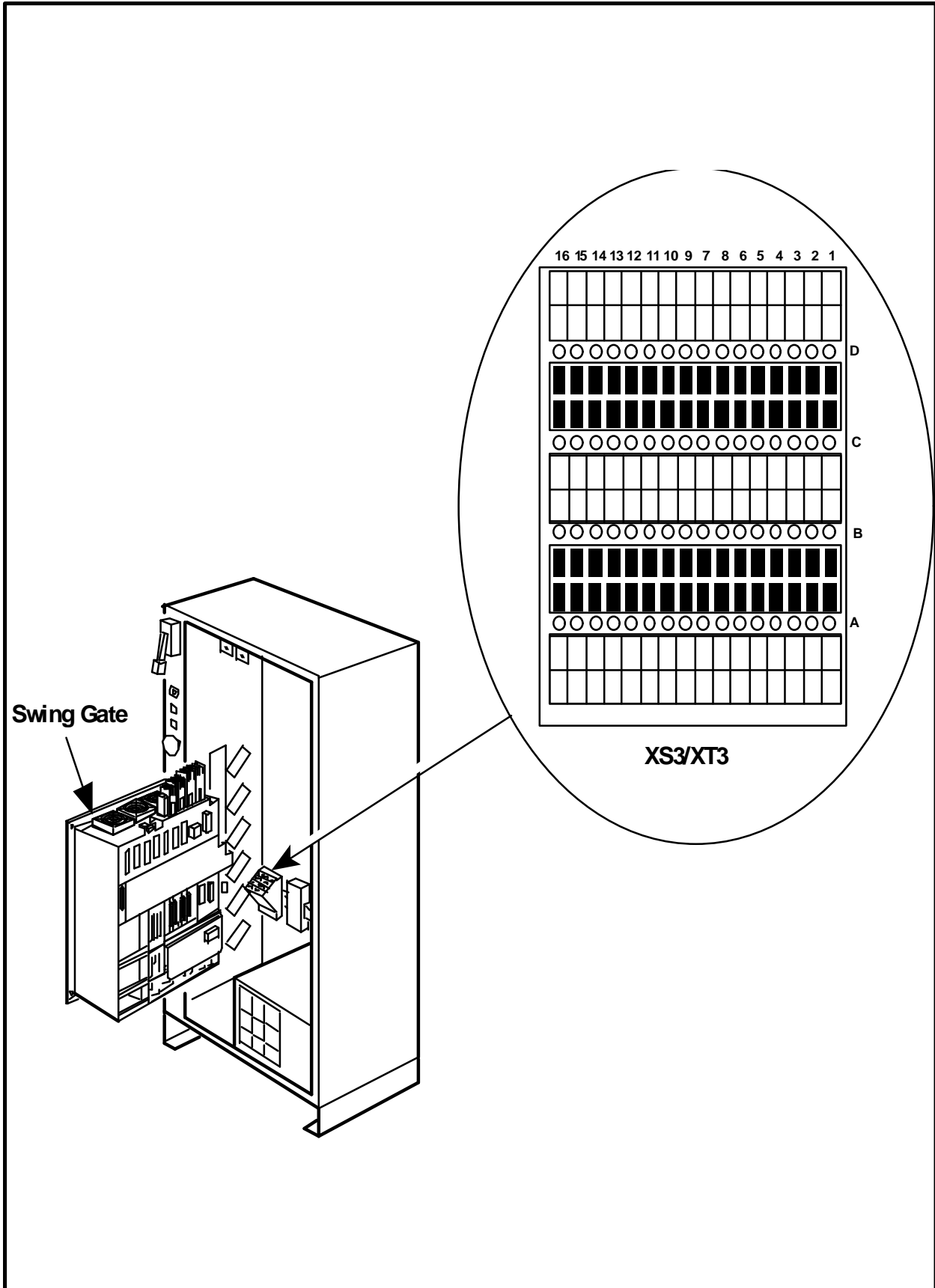

NOTES

Figure 4-5 Operator's Panel

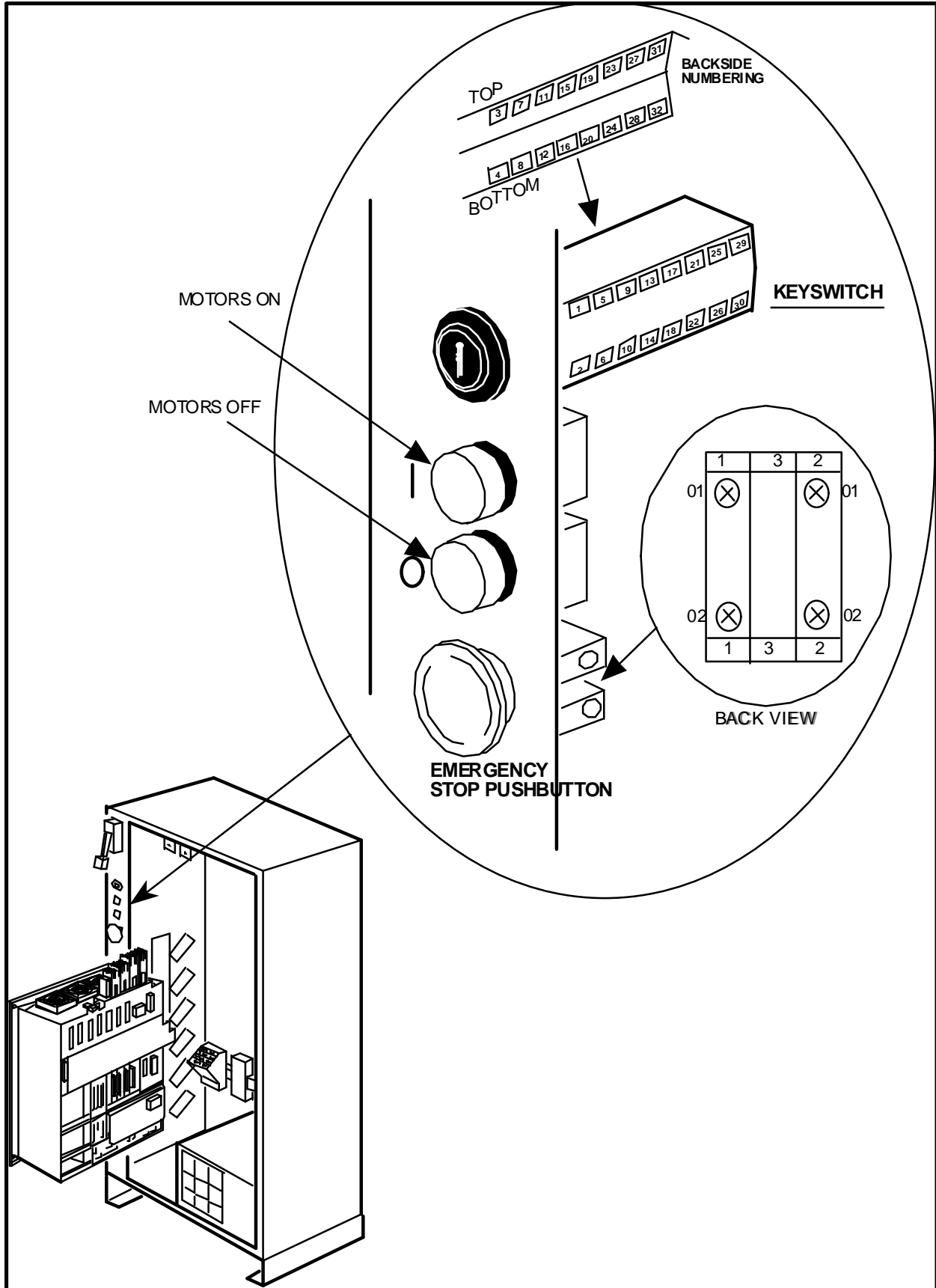

NOTES

CHAPTER 5

MOTORS ON/ DUAL RUN CHAIN CIRCUITRY

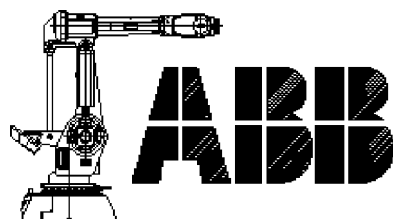

Motors ON/Dual Run Chain Circuitry

Table of Contents

5.	Motor ON/Dual Run Chain	5-3
5.1	Overview	5-3
	Diagram 5-1 Computer System and System Board.....	5-4
5.2	Manual (Reduced or Full) Speed Mode Circuit .	5-5
5.2.1	Run Chain 1	5-5
5.2.2	Run Chain 1 - Manual Stop Circuit.....	5-6
5.2.3	Run Chain 1 - General Stop (GS) Circuit.....	5-7
5.2.4	Run Chain 1 - Emergency Stop (ES) Circuit.....	5-8
5.2.5	Run Chain 1 - Limit (LIM) Circuit.....	5-9
5.2.6	Run Chain 1 - Completion.....	5-10
5.2.7	Run Chain 2	5-11
5.2.8	Run Chain 2 - Manual Stop Circuit.....	5-12
5.2.9	Run Chain 2 - General Stop Circuit.....	5-13
5.2.10	Run Chain 2 - Emergency Stop Circuit.....	5-14
5.2.11	Run Chain 2 - Limit Circuit.....	5-15
5.2.12	Run Chain 2 - Completion.....	5-16
5.3	AUTO Mode Circuit	5-17
5.3.1	Run Chain 1	5-17
5.3.2	Run Chain 2	5-18
5.4	Component Cross Reference	5-19
5.5	List of Circuit Diagrams	5-21
5.6	Component Location Figures	5-29
	Figure 5-1 Computer System and System Board.....	5-29
	Figure 5-2 Back Plane AP80	5-31
	Figure 5-3 System Board K1CR & K2CR.....	5-33
	Figure 5-4 Control Cable XS1	5-35
	Figure 5-5 Customer Connections XS3/XT3 & AP41.....	5-37
	Figure 5-6 Operator's Panel	5-39
	Figure 5-7 Power Unit	5-41
	Figure 5-8 R1.MP	5-43
	Figure 5-9 Teach Pendant.....	5-45

NOTES

5. Motor ON/Dual Run Chain

5.1 Overview

This chapter will discuss the **MOTORS ON** circuitry. There will be two sections:

1. Manual Reduced or Manual Full Speed Mode Circuitry
2. Auto Mode Circuitry.

Both sections will go through both run chain 1 & 2 circuits.

The Motors ON circuitry is made up of two series circuits known as Run Chains. Diagram 1 (on the next page) shows a representation of the dual Run Chain circuits. The purpose of having two run chain circuits for starting the motors is for safety. The two run chains must have duplicate circuits. If a component fails (such as a contact sticking) in either circuit, the other circuit can still operate the safety circuits. The two circuits are also powered in opposite directions for the purpose of safety. (Run chain 1 starts at 24 VDC and goes to 0 VDC. Run chain 2 starts at 0 VDC and goes to 24 VDC.) The two run chains control two relays (KM1 and KM2). The contacts on these two relays supply power to the Motor Drive System. If the run chains open, the KM relay will open, removing power from the drive system. If only one run chain is closed, a run chain error will be given and power is removed from the Motor Drive system.

Fig. 5-1 ➡

The status of the run chains can be monitored on the System board's (DSQC 256A) LEDs.



Back Plane is used for easy access to the individual circuits for testing.



Capacitors rated at 100 nanofarads are used throughout the circuits to reduce noise.



ABB is not responsible if safety equipment is not connected and jumpers are used to bypass an open circuit.



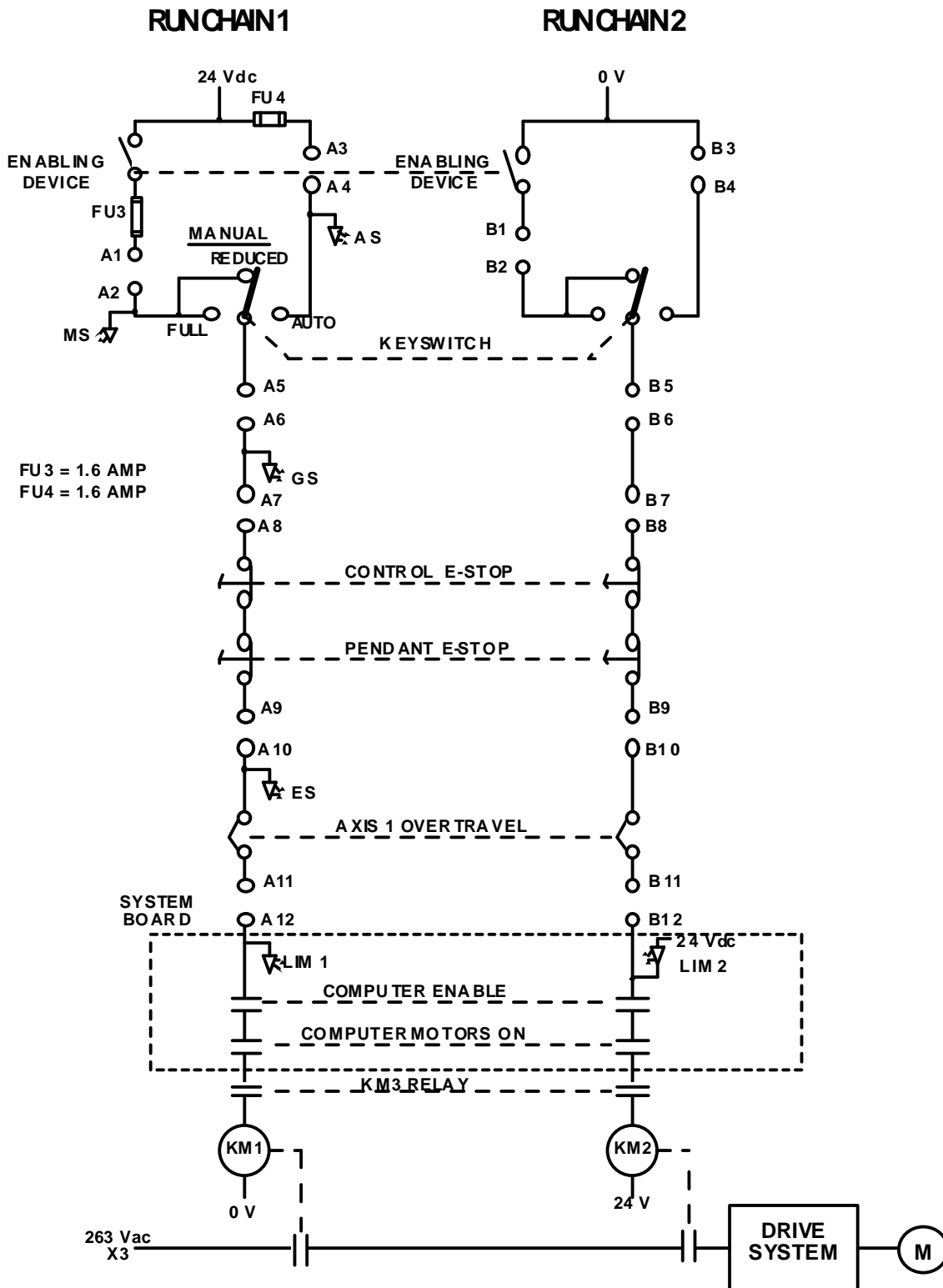

Overview (Cont)





Diagram 5-1 Computer System and System Board



5.2 Manual (Reduced or Full) Speed Mode Circuit

5.2.1 Run Chain 1



Sheet 7, line 01 
Fig. 5-1 
Fig. 5-2 
Fig. 5-9 

Sheet 7, line 02 
Fig. 5-1 
Fig. 5-2 
Fig. 5-5 

Begins on the back plane with **24 VDC**. Then:





- 24 VDC comes off the back plane AP80, through plug X32 pin 5, then goes through plug XP/XS20 pin G to the **Enabling Device** in the Teach pendant.
- When the **Enabling Device** is pulled to the center position, 24 VDC goes out of the teach pendant back to XP/XS20 pin D.
- It then goes back to the **Back Plane** through X32 pin 2.
- From the **Back Plane**, the 24 VDC goes through X35 pin 24 to the System board AP41 XP1 pin A12. (This tells the computer that the enabling device has been pulled to the center position.)
- 24 VDC will also go through a fuse FU3, (1.6 amps on the back plane) out connector X35 pin 23 then to customer connections XS3/XT3 pin A1.

5.2.2 Run Chain 1 - Manual Stop Circuit

Sheet 7, line 05 
Fig. 5-5 







Between terminals A1 and A2 the customer may wire into our **Manual Stop (MS) circuit**. This circuit can be used as a second Enable Device wired to safety mats, safety gates, safety switches or other safety circuitry that is only to be used while in Manual Reduced or Manual Full Speed modes.

Sheet 7, line 05 
Fig. 5-5 
Fig. 5-1 
Fig. 5-2 

If this circuitry is not used, a jumper is required from XS3/XT3 terminal A1 to A2. 24 VDC then goes to the System board (DSQC 256A) AP41:XP1 pin A14 and turns on the **MS LED** on the front of the System board (DSQC 256A). If the MS LED light is OFF when the Enable Device is held closed, then the circuit needs repair or the Manual Stop circuit has been opened.

5.2.3 Run Chain 1 - General Stop (GS) Circuit





The General Stop circuit:

Sheet 7, line 05 
 Fig. 5-1,2,5 
 Sheet 7, line 09 
 Sheet 7, line 13 
 Fig. 5-6 



- Begins with 24 VDC going from XS3/XT3 terminal A2 to the back plane AP80 X35 pin 10.
- Back out again X34 pin 11.
- Then to the control panel's mode select key switch terminals 8 and 4.

If the **mode key switch** is in the *AUTO* position, refer to the *AUTO* section (page 5-17) of this chapter.

If the **mode key switch** is in Manual Reduced or Manual Full speed, then:

Sheet 7, line 16 
 Fig. 5-6 
 Fig. 5-1,2 
 Fig. 5-5 



- 24 VDC goes through terminal 1 on the key switch back to the back plane AP80 X34 pin 7.
- Then out again through X35 pin 6.
- The 24 VDC then goes back to the customer connections XS3/XT3 terminal A5.

Sheet 7, line 18 
 Fig. 5-5 



Between terminals A5 and A6, the customer can wire into our **General Stop (GS) circuitry**. This circuit can be used to stop the motors of the robot in any mode and give a "General Stop" error.



If this circuit is open, the motors cannot be started and if the motors were running they will stop and the control will give an error indicating that the general stop circuit is open.

Sheet 7, line 18 
 Fig. 5-5 
 Fig. 5-2 



If this circuit is not to be used, a jumper is placed between A5 and A6. From A6, 24 VDC goes to the System board (DSQC 256A) AP41:XP1 pin A15, then to the **GS LED** on the front of the System board (DSQC 256A). If the **GS LED** is OFF and the Enable Device is held closed, then the circuit needs repair or the General Stop circuit is open.

Sheet 7, line 18 
 Sheet 8, line 08 
 Fig. 5-5 

The 24 VDC from A6 also goes to A7 on XS3/XT3.

5.2.4 Run Chain 1 - Emergency Stop (ES) Circuit

The Emergency Stop circuitry:

Sheet 8, line 07 
Fig. 5-5 



Sheet 8, line 06 
Fig. 5-1,2 

Fig. 5-6 

- Begins from XS3/XT3 terminal A7. (The customer may wire in additional Emergency Stop circuits between XS3/XT3 terminals A7 and A8. If the customer is not using this circuit then a jumper is placed between XS3/XT3 terminals A7 and A8.)
- From terminal A8, 24 VDC goes to the back plane X35 pin 1.
- It goes out again X34 pin 4.
- From X34 pin 4 it leads to the control panel Emergency Stop push button terminal 12.

If the **Control Panel Emergency Stop** button is NOT pressed in:









Sheet 8, line 06 
Fig. 5-6 
Sheet 8, line 02 
Fig. 5-1,2 

Fig. 5-9 

- 24 VDC will go through terminal 11 to the back plane X34 pin 23.
- Then off the back plane through X32 pin 1 to XS/XP20 pin "K".
- Out to the teach pendant's Emergency Stop push button.



If the **Teach Pendant's Emergency Stop** button is NOT pressed then:

Sheet 8, line 01 
Fig. 5-1,2 

Sheet 8, line 06 
Fig. 5-5 

- 24 VDC will come back to the control panel through XS/XP20 pin "L".
- Then back to the back plane X32 pin 9.
- Then past a noise reducing capacitor off the back plane X35 pin 3.
- To XS3/XT3 terminal A9.

Again, at this point the customer may wire in additional emergency stop circuits such as safety gates, light beams, etc. between XS3/XT3 terminals A9 and A10. If the customer is not using this circuit then a jumper is placed between XS3/XT3 terminals A9 and A10.



Sheet 8, line 09 
Fig. 5-5 
Fig. 5-2 

- From terminal A10, 24 VDC goes to the System board (DSQC 256A) AP41:XP1 pin A16 and then to the **ES LED** on the front of the System board (DSQC 256A).



If the LED is NOT lit and the Enable Device is held in, then the circuit is open and either needs repair or an E-Stop has been activated.

5.2.5 Run Chain 1 - Limit (LIM) Circuit

Sheet 8, line 10 
 Fig. 5-5 

The Limit circuitry:







- Begins with 24 VDC at XS3/XT3 terminal A10.
- Then it goes to XS3/XT3 terminal A11 (which is supplied for the customer to wire into our **Limit (LIM) circuitry**.)

Fig. 5-8 





The customer may use this circuit to stop the robot from an over travel on external axis or a break-away device attached to the wrist of the robot or other such circuits. If this circuit is opened it will stop the robot and generate a Limit error. By pressing and holding the Motors ON push button the customer may move the robot off of the problem and continue running the robot. If this circuit is not to be used by the customer then it should be jumped between XS3/XT3 terminals A11 and A12.



Sheet 8, line 11 
 Fig. 5-5 
 Sheet 13.1, line 16..... 
 Sheet 105, line 14..... 
 Fig. 5-4 
 Fig. 5-8 



- From terminal A12, 24 VDC goes into a noise suppressor (Z2) terminal 1 and out terminal 2.
- Then to the manipulator through XS1 pin D2 to R1.MP pin D2.

At this point the robot may have the optional axis one Over Travel Limit switch wired from R1.MP pin D2 to D4. This switch will open when the robot moves against the axis 1 hard stop. If the robot does not have this option then a jumper will go on R1:MP pin D2 to D4.

Sheet 13.1, line 16..... 
 Fig. 5-4 
 Sheet 15, line 16 

- 24 VDC will return to the control on XS1 pin D4.
- Then to XS22 pin 7.

Then if external axes are present (axis 7-12) the customer may wire a limit switch to XS7 pin A4 to A5. Otherwise 24VDC is jumpered from XS22 pin 7 to XS22 pin 10.

Sheet 8, line 16 
 Fig. 5-1,2,5 

- Then 24 VDC goes through XS/XP18 pin 8 to the System board (DSQC 256A) AP41:XP1 pin C15.
- This turns on the **LIM 1 LED** (the left one) on the System board (DSQC 256A).

5.2.6 Run Chain 1 - Completion





Sheet 8, line 16 
Fig. 5-3 

Fig. 5-1,2 
Sheet 8, line 17 



On the **System board** (DSQC 256A):

- 24 VDC then goes through K1CR relay contacts.







K1CR is controlled by the System board's (DSQC 256A) enable signal. If the computer boards do not detect any faults and the System board (DSQC 256A) has no faults the "EN" LED on the front of the System board (DSQC 256A) will light and K1CR will energize.

- 24 VDC then goes to K2CR contacts on the System board (DSQC 256A).

This relay is also controlled by the computer. If the computer has a serious error, fault or you are trying to operate the motors while viewing the parameters, the computer will not energize this relay. If these don't apply:

Sheet 8, line 17 

- Then the computer will energize K2CR allowing 24 VDC to go out System board (DSQC 256A) AP41:XP1 pin C28.
- Then to the power unit KM3 terminal 33.

Sheet 9, line 04 
Fig. 5-7 
Sheet 9, line 08 
Sheet 9, line 07 
Fig. 5-7 
Sheet 9, line 08 
Sheet 9, line 08 



If KM3 is energized (it should be if power is ON):

- Then 24 VDC goes to KM1 relay coil terminal A2.
- This will pull in KM1 closing contacts 44 and 43 latching around the KM3 contacts 33 and 34.
- KM1 will close contacts 7 and 8 (part of the Brake Release circuit).
- KM1 will close contacts 2, 4, and 6 sending 262 VAC to KM2 contacts 1, 3 and 5.
- KM1 will open contacts 11 and 12.*
- KM1 will open contacts 21 and 22.*

* These two sets of contacts and KM2 will disable the KM3 relay.

Fig. 5-5 



The KM1 contacts 33 and 34 are for customer use. These contacts can be accessed at XS3/XT3 terminals A13 and A14.

Sheet 8, line 18 
Fig. 5-1,2 



The **ERR LED** will light if the System board (DSQC 256A) detects that neither MON or MOFF is on. This means that one Run Chain is open.

5.2.7 Run Chain 2

Sheet 8, line 16 
Fig. 5-1,2 

Run Chain 2 has its power source supplied on the System board's (DSQC 256A) **LIM 2 LED** (the right one). The other side of the LED goes through a duplicate of Run Chain 1 connections going to 0V. **LIM 2 LED** is the only LED for Run Chain 2, because under normal conditions, Run Chain 1 and Run Chain 2 have the same status. To trace these circuits, we start at **LIM 2 LED**. Instead of checking for 24 VDC we will be checking for 0 VDC.





This is done by connecting the red meter lead to a known 24 VDC source, such as, XS3/XT3 terminal D16, and putting the black lead on the terminal points. If the meter reads 24 VDC the circuits are intact to 0V.



Remember while checking these circuits have someone hold the enabling device in the center position.



5.2.8 Run Chain 2 - Manual Stop Circuit

Sheet 7, line 02 
Fig. 5-1,2,9 



Run Chain 2 begins on back plane with 0 VDC.

- 0 VDC goes out X32 pin 8.
- In XS/XP20 pin "F".
- Out to the teach pendant's enabling device.

When the enabling device is pulled to the center position:

Sheet 7, line 02 
Fig. 5-1,2 

- 0 VDC will go out XS/XP20 pin "E".
- In to the back plane X32 pin 3.
- 0 VDC goes out X35 pin 8.
- To the customer connection XS3/XT3 terminal B1.

Sheet 7, line 05 
Fig. 5-5 

This is where the customer can wire into the Manual Stop circuitry as was done for Run Chain 1. If this is NOT used, a jumper is placed between XS3/XT3 terminals B1 and B2.

5.2.9 Run Chain 2 - General Stop Circuit

The General Stop circuit:

Sheet 7, line 05
Fig. 5-5

- Beginning at XS3/XT3 terminal B2, 0 VDC can be traced to the back plane X35 pin 7.
- Out from X34 pin 6.
- To the key switch, terminals 10 and 12.

Sheet 7, line 13
Fig. 5-6

As long as the key switch is turned to manual (reduced or full) speed mode:

Sheet 7, line 16
Fig. 5-1,2

- 0 VDC will go out the key switch terminal 5.
- To the back plane X34 pin 8.

Then 0 VDC goes off the back plane X35 pin 5 to return to XS3/XT3 terminal B5.



Sheet 7, line 17
Fig. 5-5

The **General Stop circuitry** is where the customer can wire external safety devices as was done for Run Chain 1. If this circuitry is not to be used, then a jumper is placed between XS3/XT3 terminals B5 to B6.

Sheet 8, line 08

- 0 VDC will then go from XS3/XT3 terminal B6 to XS3/XT3 terminal B7.

5.2.10 Run Chain 2 - Emergency Stop Circuit



Sheet 8, line 08 
Fig. 5-5 

The **Emergency Stop circuitry** is where the customer can wire external safety devices, as was done for Run Chain 1. If this circuit is not to be used by the customer, then a jumper must be placed between XS3/XT3 terminals B7 and B8.

Fig. 5-1,2,6 



- 0 VDC goes from XS3/XT3 terminal B8 to the back plane X35 pin 2.
- Out of the back plane X34 pin 3.
- To the Control Emergency Stop push button terminal 21.

If the Emergency Stop button is not pressed in:



Sheet 8, line 05 
Sheet 8, line 03 
Fig. 5-1,2,6 

- 0 VDC goes out terminal 22.
- To the back plane X34 pin 22.
- Out X32 pin 4.
- In XS/XP20 pin "H".
- Out to the Teach Pendant's Emergency Stop push button.



If the Emergency Stop push button is not pressed in:

Sheet 8, line 20 
Fig. 5-1,2 



- 0 VDC will be traced back to XS/XP20 pin "M".
- Into the back plane X32 pin 6.
- Out the back plane X34 pin 4.
- Into XS3/XT3 terminal B9.

Sheet 8, line 05 
Fig. 5-5 

This is another place where the customer can wire into the Emergency Stop circuitry, like Run Chain 1. If the customer is not using this circuit then a jumper is placed between B9 and B10.

Sheet 8, line 09 
Fig. 5-5 

5.2.11 Run Chain 2 - Limit Circuit



Sheet 8, line 09 
Fig. 5-5 
Sheet 8, line 11 

From B10:

- 0 VDC can be traced to B11 and the start of the limit circuitry.

This is where the customer can wire into the limit circuitry like Run Chain 1.

If not using the limit circuitry then a jumper is placed on XS3/XT3 terminals B11 and B12.

Sheet 8, line 11 
Fig. 5-5 



- 0 VDC goes from B12 into capacitor Z2 (a noise suppressor) terminal 3.
- Out terminal 4 of Z2.
- Into XS1 pin D1.
- Out to the manipulator R1.MP pin D1.

This is where an optional limit switch can be placed on the Axis 1 hard stop. If the robot moves against the Axis 1 hard stop, this circuit will open. If this option is not used then a jumper is placed between pins D1 and D3.

Sheet 15, line 16 



- 0 VDC goes back to XS1 pin D3.
- Then to XS22 pin 8.

Then if external axes are present (axes 7-12) the customer may wire a limit switch to XS7 pin B4 to B5. Otherwise 0V is jumpered on XS22 from pin 8 to pin 9.



Sheet 8, line 16 
Fig. 5-1,2,4,5 ... 

- To any external axis limit switches (if used).
- To XS/XP18 pin 9.
- From there 0 VDC goes to the System board (DSQC 256A) pin C16. This causes the **LIM 2 LED** to light, indicating that **Run Chain 2** is **intact**.



5.2.12 Run Chain 2 - Completion

Sheet 8, line 16 
Fig. 5-1,2 



Sheet 8, line 18 

Sheet 9, line 04 
Fig. 5-7 

Sheet 9, line 08 

Sheet 9, line 07 
Sheet 9, line 11 

Sheet 9, line 10 

Sheet 9, line 08 
Fig. 5-1,2 



On the **System board** (DSQC 256A) K1CR and K2CR will work the same as for run chain 1:

- Sending 0 VDC off the System board (DSQC 256A) AP41:XP1 pin C29.
- To KM3 contact 43.
- KM3 will be energized, closing KM3 contacts 43 and 44.
- This allows 0 VDC to go to KM2 terminal A2, energizing KM2.
- KM2 will latch in through contacts 44 and 43.
- KM2 contacts 7 and 8 will send a signal to the System board (DSQC 256A) called Motors ON at AP41:XP1 pin A23.
- KM2 contacts 2, 4, and 6 will close, sending 262 VAC to the Drive unit.
- KM2 will open contacts 11 and 12.*
- KM2 will open contacts 21 and 22.*



* These two sets and KM1 contacts 21 & 22 will disable the KM3 relay.



The **ERR LED** will light if the System board (DSQC 256A) detects that neither MON or MOFF is on. This may mean that one of the Run Chains is open.

5.3 AUTO Mode Circuit

The AUTO Mode circuit is very similar to the Manual Mode circuits. The difference is in the beginning of the run chains before the key switch. The AUTO mode circuits bypass the Manual Stop circuits.



5.3.1 Run Chain 1

Sheet 7, line 16 
 Fig. 5-1,2 

Sheet 7, line 07 
 Fig. 5-5 

- Starts on the back plane with 24 VDC.
- Goes through FU4 (1.6 amp fuse).
- Out X35 pin 20.
- To XS3/XT3 terminal A3.

This is where the customer can wire into our **Auto Stop (AS)** circuit between XS3/XT3 terminals A3 and A4. This circuit will stop the robot from running only while the key switch is AUTO mode. If this circuit is not used then the customer may place a jumper between XS3/XT3 terminal A3 to A4.



Sheet 7, line 09 
 Fig. 5-1,2 

- 24 VDC then goes from A4 to the back plane X35 pin 11.
- Also to the System board (DSQC 256A) AP41:XP1 pin A13, to the **AS LED** on the front of the System board (DSQC 256A).



If this LED's not on, then the circuit is open and needs repair or closing of the AS circuit.

Sheet 7, line 11 



Sheet 7, line 14 
 Fig. 5-6 

- 24 VDC comes off the back plane through X34 pin 10.
- To the key switch terminal 2.



If the key switch is in the AUTO mode:

- 24 VDC will go out through terminal 1 on the key switch and then continue as it did for Manual modes.



5.3.2 Run Chain 2

Sheet 7, line 03 
Fig. 5-1,2,5 

- 0 VDC can be traced out the back plane X35 pin 21.
- Into XS3/XT3 terminal B3.

Sheet 7, line 05 
Fig. 5-5 

This is where the customer may wire into the AUTO stop circuit just as was done for Run Chain 1. If this circuit is not used then a jumper goes between B4 and B3.

Sheet 7, line 09 
Fig. 5-1,2 

Sheet 7, line 14 

- 0 VDC can be traced to the back plane X35 pin 9.
- Into X34 pin 12.
- To the Key Switch terminal 6.

Fig. 5-6 

If the Key Switch is in AUTO mode, 0 VDC goes through terminal 5 and continues like the Manual mode circuit.

5.4 Component Cross Reference

Component Name	Component Location	Circuit Diagram Number	Location Figure
Back plane AP80	Swing gate, back	Sheet 7	5-1,5-2
Back plane X32	Swing gate, bottom	Sheet 7, 8	5-1,5-2
Back plane X34	Swing gate, bottom	Sheet 7, 8	5-1,5-2
Back plane X35	Swing gate, bottom	Sheet 7, 8	5-1,5-2
Customer Connection XS3/XT3	Cabinet, back	Sheet 7, 8	5-5
Enabling Device	Teach pendant	Sheet 7, 8	5-9
Fuse FU3	Swing gate, bottom	Sheet 7	5-1,5-2
K1CR and K2CR	System board	Sheet 8	5-3
KM1 and KM2 and KM3	Swing gate, Top	Sheet 9	5-7
Mode select key switch	Cabinet, front	Sheet 7	5-6
Noise suppressor Z2	Swing gate, back	Sheet 8	5-5
R1:MP	Manipulator	Sheet 105	5-8
System board AP41:XP1	Swing gate, back	Sheet 7, 8	5-5
Teach Pendant	Cabinet, front	Sheet 7, 8	5-9
XS/XP 18	Swing gate, Top	Sheet 8	5-5
XS1/XP1	Cabinet, left	Sheet 13.1	5-4
XS/XP20	Front door	Sheet 7, 8	5-9
XS/XP22	Cabinet, back	Sheet 8	5-5

NOTES

5.5 List of Circuit Diagrams

1.	MOTOR ON CHAIN PART 1	7 of 43
2.	MOTOR ON CHAIN PART 2	8 of 43
3.	POWER UNIT	9 of 43
4.	CONTROL CABLE	13.1 of 43
5.	EXTERNAL AXES 7-8	15 of 43
6.	AXIS 1	105 of 12

NOTES

Figure 5-1 Computer System and System Board

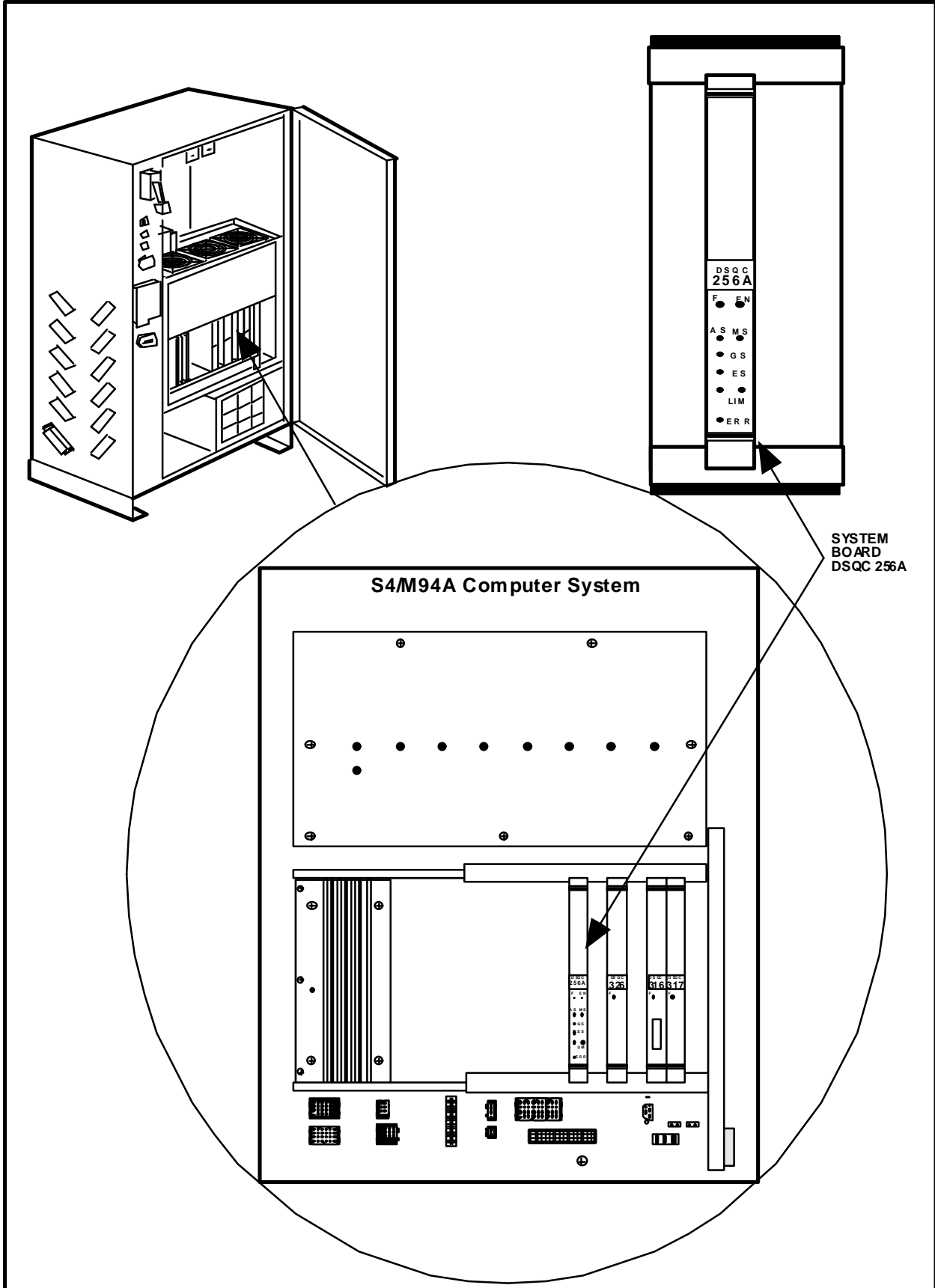

NOTES

Figure 5-2 Back Plane AP80

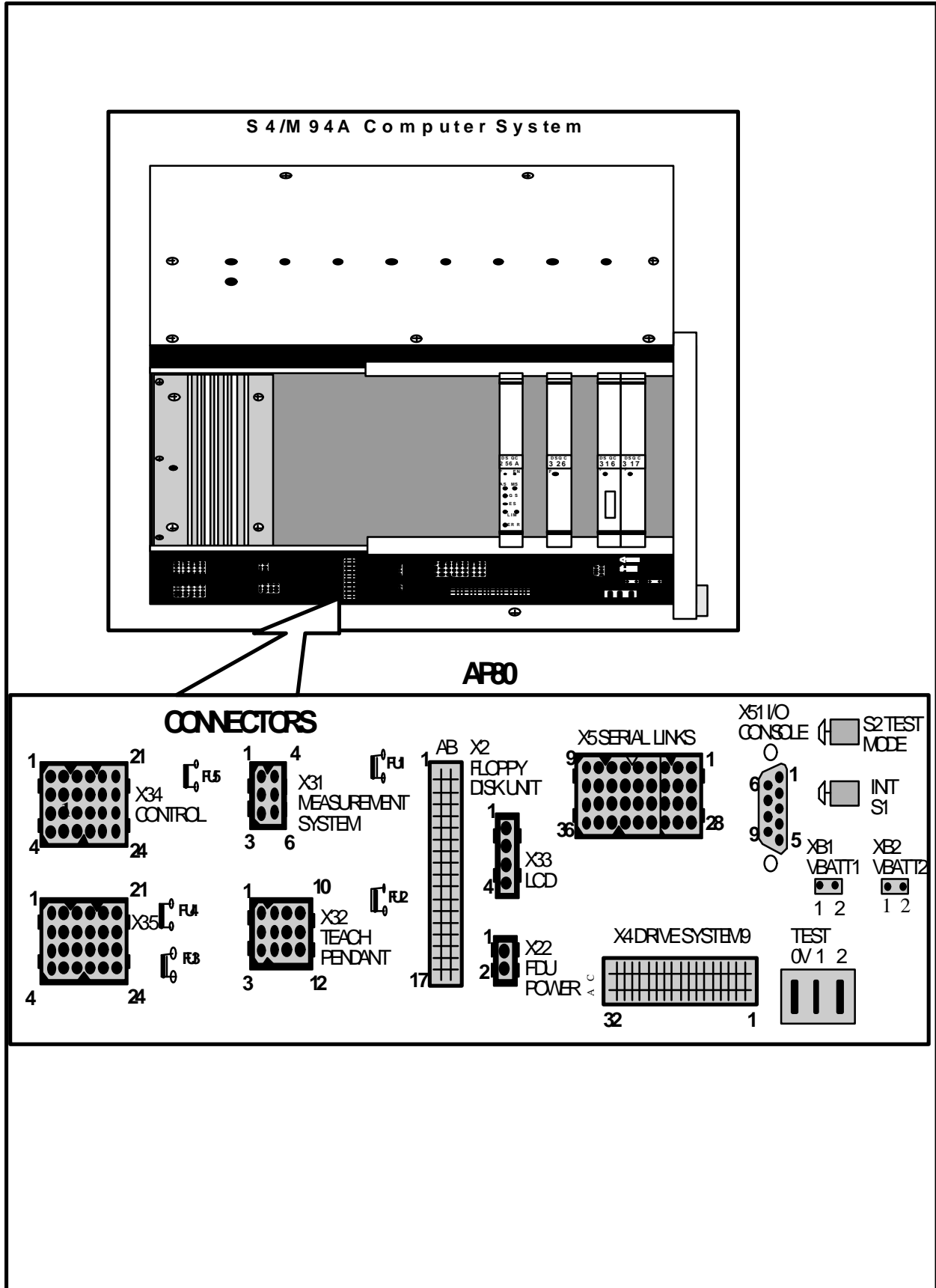

NOTES

Figure 5-3 System Board K1CR & K2CR

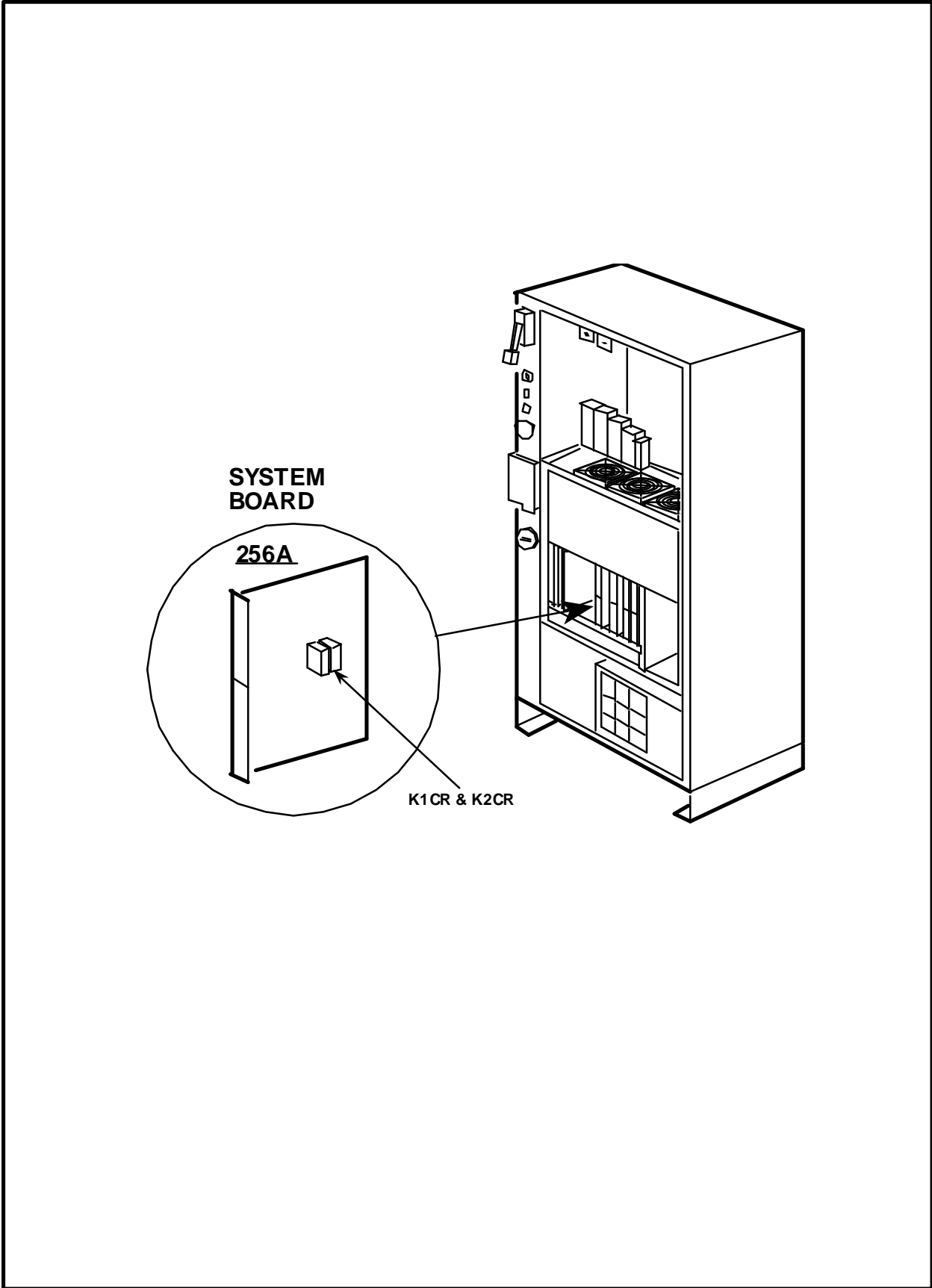

NOTES

Figure 5-4 Control Cable XS1

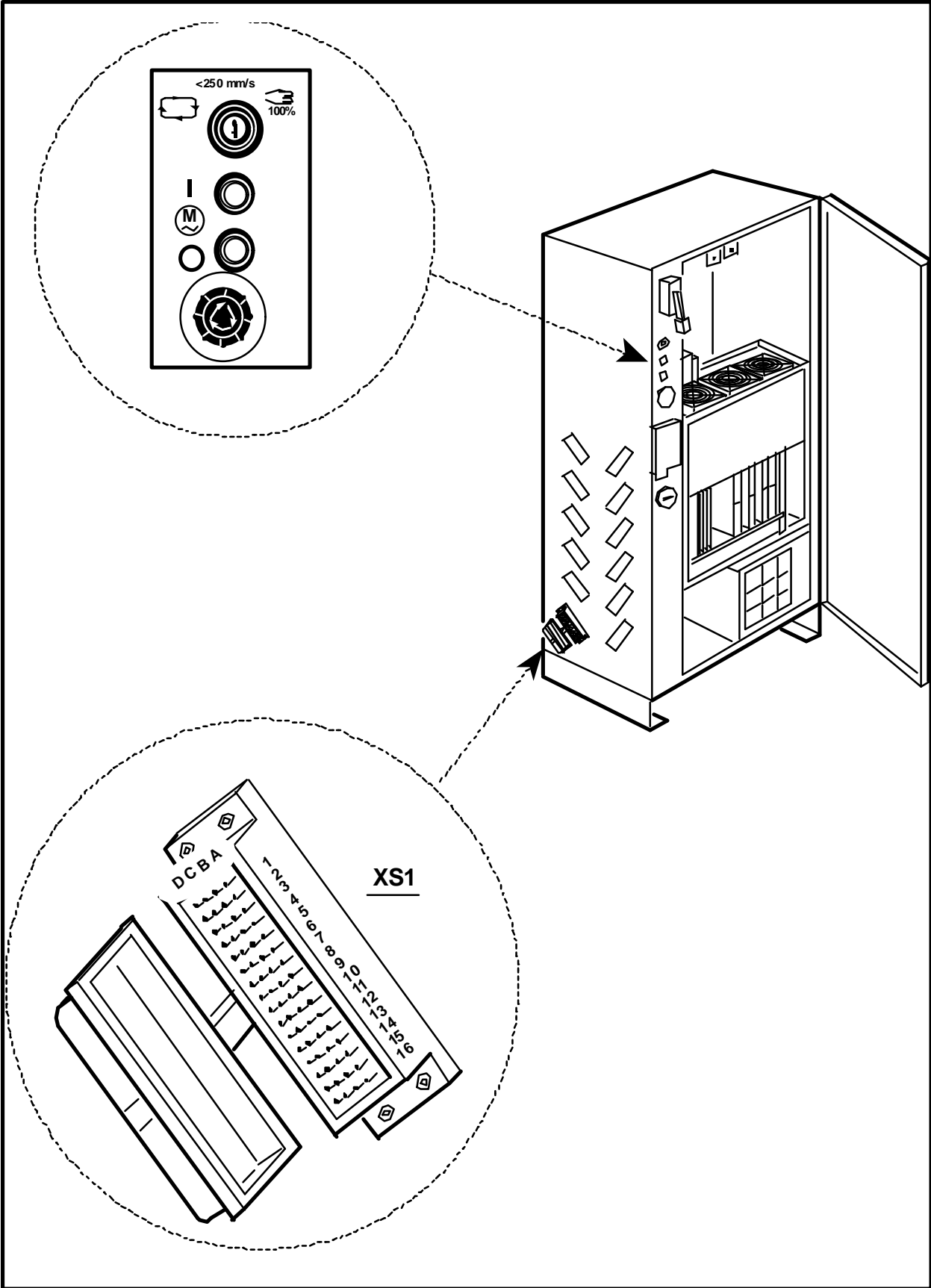

NOTES

Figure 5-5 Customer Connections XS3/XT3 & AP41

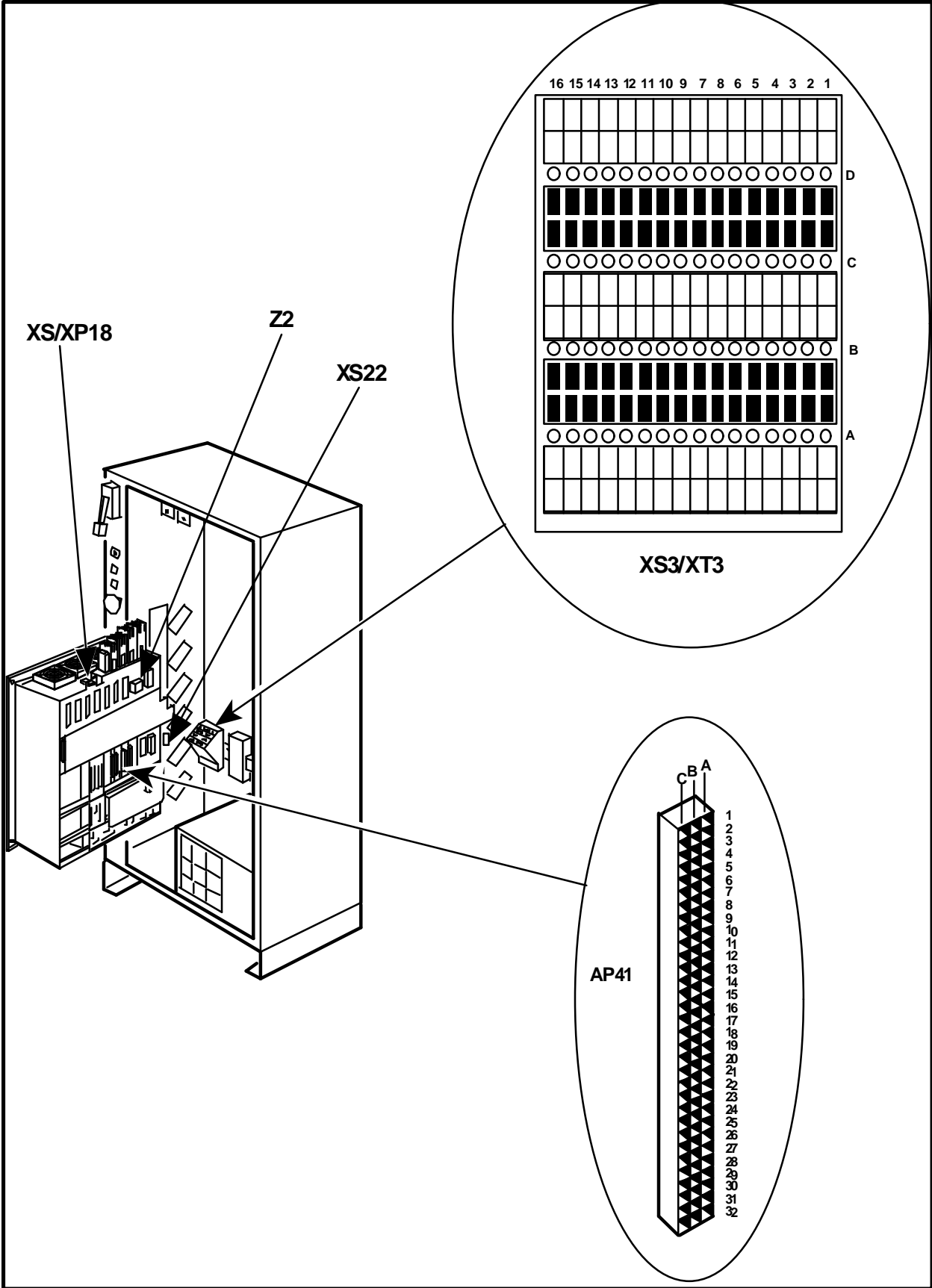

NOTES

Figure 5-6 Operator's Panel

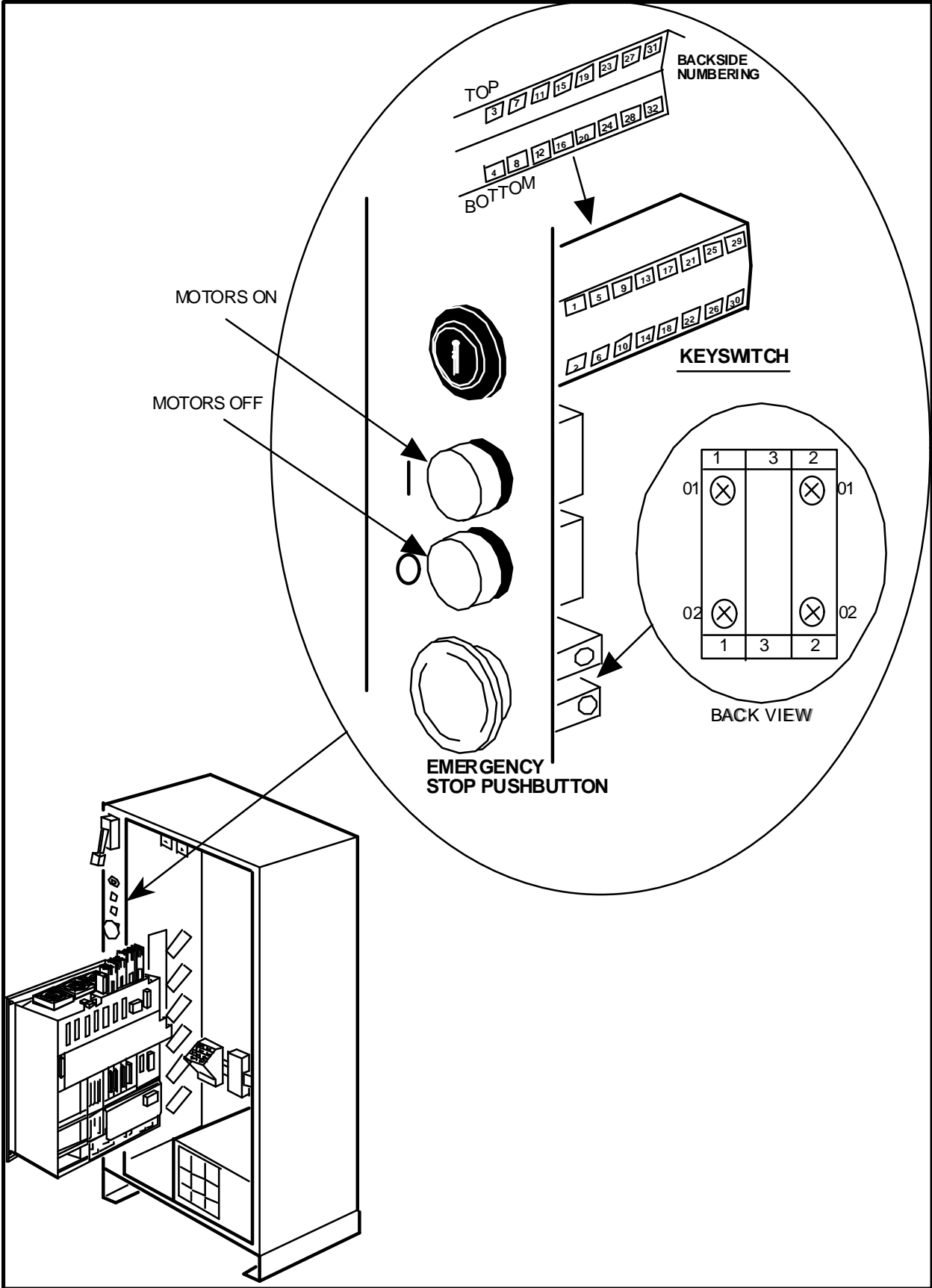

NOTES

Figure 5-7 Power Unit

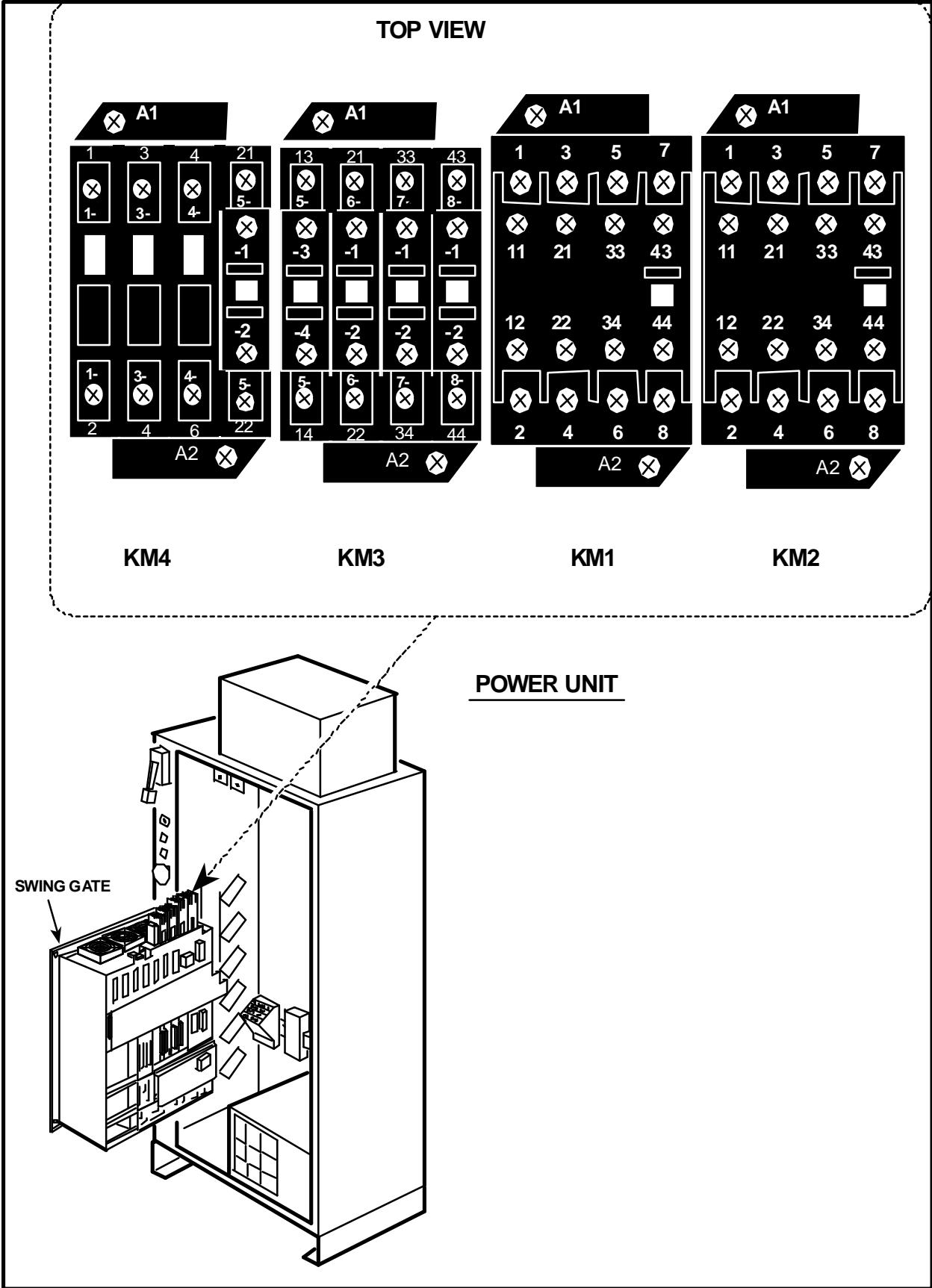

NOTES

Figure 5-8 R1.MP

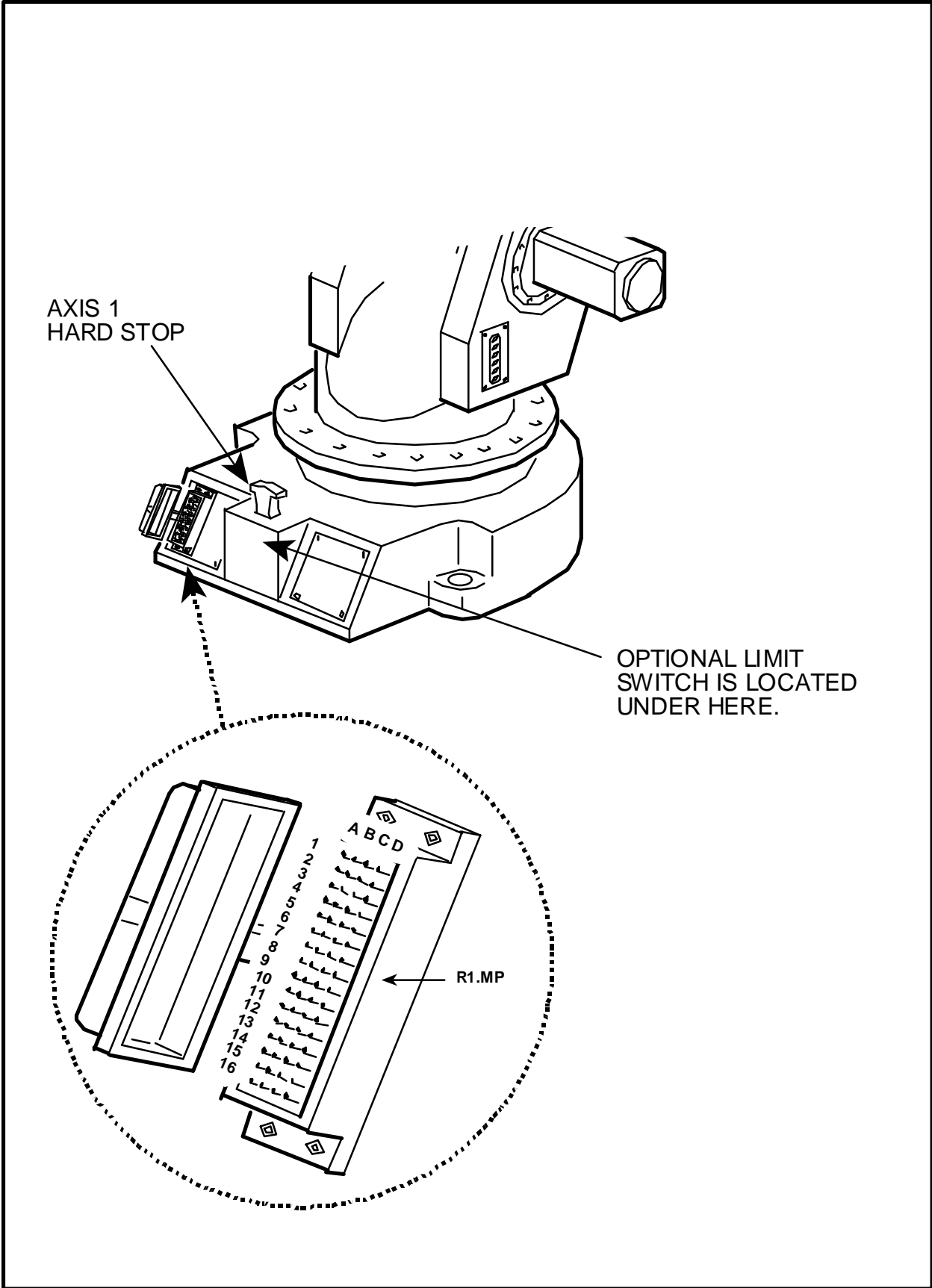

NOTES

Figure 5-9 Teach Pendant

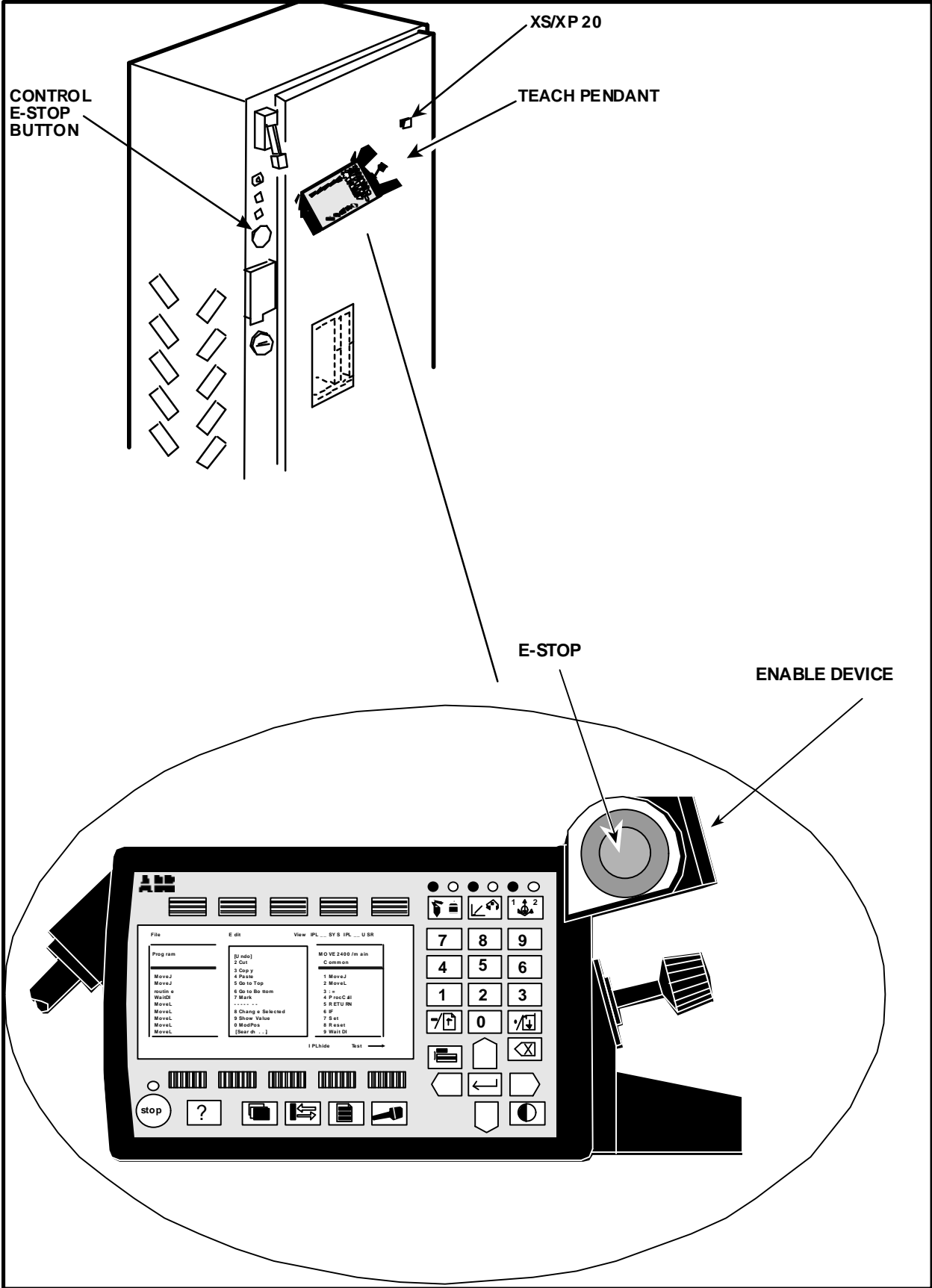

NOTES

CHAPTER 6

EMERGENCY STOP CIRCUITRY

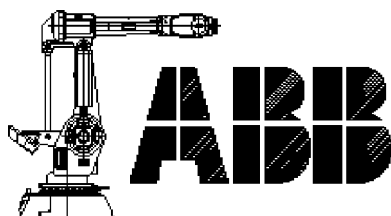

Emergency Stop Circuitry

Table of Contents

6.	Emergency Stop.....	6-3
6.1	Overview	6-3
6.2	Emergency Stop - Run Chain 1	6-4
6.3	Emergency Stop - Run Chain 2	6-6
6.4	Emergency Stop - Reset Circuit	6-8
6.5	Component Cross Reference	6-9
6.6	List of Circuit Diagrams	6-11
6.7	Component Location Figures	6-15
	Figure 6-1 Teach Pendant.....	6-15
	Figure 6-2 Computer System & System Board.....	6-17
	Figure 6-3 Back Plane AP80	6-19
	Figure 6-4 Operator's Panel.....	6-21
	Figure 6-5 Customer Connections XS3/XT3.....	6-23

NOTES

6. Emergency Stop

Sheet 8

6.1 Overview

Fig. 6-1

The robot has two Emergency Stop push buttons.

- One is located on the operators panel.
- The other is located on the teach pendant.

Both Emergency Stop buttons have normally closed contacts. When the Emergency Stop button is pressed, the button will remain pressed in and will open the contacts.

If the Emergency Stop circuitry is opened:

- a) The robot will stop immediately.
- b) The motors will have power disconnected from them.
- c) An error (20002 - Emergency Stop) will be generated on the teach pendant.
- d) The "ES" LED (on the system board) will go off indicating that the run chain has been interrupted.
- e) When the LED goes OFF, KM1 and KM2 relays will open, removing power from the drives.



To reset the button, either twist the button or pull on button until it returns to its OUT position. Press the 'OK' button on the Teach Pendant to clear the error.



You are also required to press the Motors OFF button to reset the emergency stop condition. Both Emergency Stop buttons also have dual contacts, one for each run chain.

The robot also supplies two 24 VDC circuits on XS3/XT3 (customer connections) for the customer to wire into the emergency stop circuitry. There are circuits provided for both run chains.



It is important to use both run chain circuits to ensure proper error identification by the computer. *If only one run chain circuit is used, run chain errors will appear instead of emergency stop errors.*

This chapter is in three sections. One for Run Chain 1, one for Run Chain 2, and the third for the circuits used to reset an Emergency Stop.

6.2 Emergency Stop - Run Chain 1



While trouble shooting this circuit, hold the enable device in or turn the mode select switch to AUTO mode.

For Run Chain 1:

Sheet 8, line 08
Fig. 6-5

- The emergency stop circuit starts with 24 VDC at XS3/XT3 terminal A7.
If 24 VDC is not at XS3/XT3 terminal A7, then refer to Chapter 5 - Motors ON.

Between XS3/XT3 terminals A7 and A8 is the first place that the customer can connect series circuits to cause the robot to go into an emergency stop condition when the circuit is open.

If the customer is not using a customer connected Emergency Stop, then a jumper is placed between XS3/XT3 terminals A7 and A8.

Sheet 8, line 06
Fig. 6-2,3

- 24 VDC then goes through XS3/XT3 terminal A8 to the back plane X35 pin 1.
- Past a noise reduction capacitor C2, out the back plane X34 pin 4 to the Control Panel Emergency Stop push button terminal 12.

Fig. 6-4

If the **Emergency Stop button** on the Control Panel is pulled OUT:

Sheet 8, line 02
Fig. 6-2,3
Fig. 6-1

- 24 VDC will go out terminal 11.
- To the back plane X34 pin 23.
- Out the back plane X32 pin 1.
- To XS/XP 20 pin "K". (XS/XP20 is the connector to the teach pendant.)
- XS/XP 20 pin "K" goes through the Emergency Stop button on the teach pendant back to the XS/XP20 pin "L".
- To the back plane X32 pin 9.
- Past a noise reducing capacitor (C4) to X35 pin 3.
- Then to XS3/XT3 terminal A9.

Emergency Stop - Run Chain 1 (Cont)

Between XS3/XT3 terminals A9 and A10 is the second place that the customer can connect series circuits to cause the robot to go into an emergency stop condition when the circuit is open.

Fig. 6-5 ➤

If the customer is not using a customer connected Emergency Stop, then a jumper is placed between XS3/XT3 terminals A9 and A10.

Sheet 8, line 08 ✎

Fig. 6-2,3,5 ➤

- 24 VDC goes from XS3/XT3 terminal A10 to the system board (DSQC 256A) AP41:XP1 pin A16.

On the System board, the 24 VDC turns on a light on the front of the System board labeled "ES", indicating that the Emergency Stop circuit is OK.

6.3 Emergency Stop - Run Chain 2



While trouble shooting this circuit, hold the enable device in or turn the mode select switch to AUTO mode. Remember also that you are tracing **0 VDC**. So put the RED meter lead on a known 24 VDC source (XS3/XT3 terminal A16) and make checks with the BLACK meter lead. A reading of 24 VDC on the meter indicates that the circuit is OK.

For Run Chain 2:

- Start with 0 VDC at XS3/XT3 pin B7.

Between XS3/XT3 terminals B7 and B8 is the first place that the customer can connect series circuits to cause the robot to go into an emergency stop condition when the circuit is open.

If the customer is not using a customer connected Emergency Stop, then a connection between XS3/XT3 terminals B7 and B8 is necessary (just like Run Chain 1 with A7 and A8).

- 0 VDC then goes through XS3/XT3 terminal B8 to the back plane X35 pin 2.
- Past a noise reduction capacitor C1, out the back plane X34 pin 3 to the Control Panel Emergency Stop push button terminal 21.

If the **Emergency Stop** button on the Control Panel is pulled OUT:

- 0 VDC will go out terminal 22.
- To the back plane X34 pin 22.
- Out the back plane X32 pin 4.
- To XS/XP 20 pin "H". (XS/XP20 is the connector to the teach pendant.)
- XS/XP 20 pin "H" goes through the Emergency Stop button on the teach pendant back to the XS/XP20 pin "M".
- To the back plane X32 pin 6.
- Past a noise reducing capacitor (C3) to X35 pin 4.
- Then to XS3/XT3 terminal B9.

Sheet 8, line 08
Fig. 6-5

Sheet 8, line 06
Fig. 6-2,3



Fig. 6-4

Sheet 8, line 02
Fig. 6-1

Sheet 8, line 01

Sheet 8, line 05
Fig. 6-5

Emergency Stop - Run Chain 2 (Cont)

Sheet 8, line 07 
Fig. 6-5 

Between XS3/XT3 terminals B9 and B10 is the second place that the customer can connect series circuits to cause the robot to go into an emergency stop condition when the circuit is open.

If the customer is not using a customer connected Emergency Stop, then a connection between XS3/XT3 terminals B9 and B10 is necessary (just like Run Chain 1 with A9 and A10).

- From B10, 0 VDC goes to the Limit circuitry.



There is no LED to indicate that the Emergency Stop circuit is open for Run Chain 2, other than the LIM2 LED which indicates Run Chain 2 is open somewhere.

6.4 Emergency Stop - Reset Circuit

Fig. 6-4 ➤

The **Emergency Stop Reset circuit** uses the Motors OFF push button. When the Motors OFF push button is pressed:

Sheet 7, line 14 📄

- **24 VDC** goes from the back plane X34 pin 24.
- To the Control Panel's Motors OFF push button terminal 14.
- When the button is pressed, 24 VDC will go through to terminal 13.
- Back to the back plane X34 pin 9.

Sheet 8, line 16 📄

This is where the computer picks up the signal as Emergency Stop Reset and allows K2CR on the System board to close when attempting to turn the motors ON after an emergency stop.

6.5 Component Cross Reference

Component Name	Component Location	Circuit Diagram Number	Location Figure
XS3/XT3	Cabinet, back	Sheet 8	6-5
Back plane X32, X34, X35	Swing gate, bottom	Sheet 8	6-2,6-3
Control panel E-stop	Cabinet, front	Sheet 8	6-1,6-4
XS/XP 20	Cabinet, front	Sheet 8	6-1
Teach pendant	Cabinet, front	Sheet 8	6-1
System board (DSQC 256A)	Swing gate, bottom	Sheet 8	6-2,6-3
Control panel Motors Off	Cabinet, front	Sheet 7	6-4

NOTES

6.6 List of Circuit Diagrams

1. MOTOR ON CHAIN PART 1 7 of 43
2. MOTOR ON CHAIN PART 2 8 of 43

NOTES

Figure 6-1 Teach Pendant

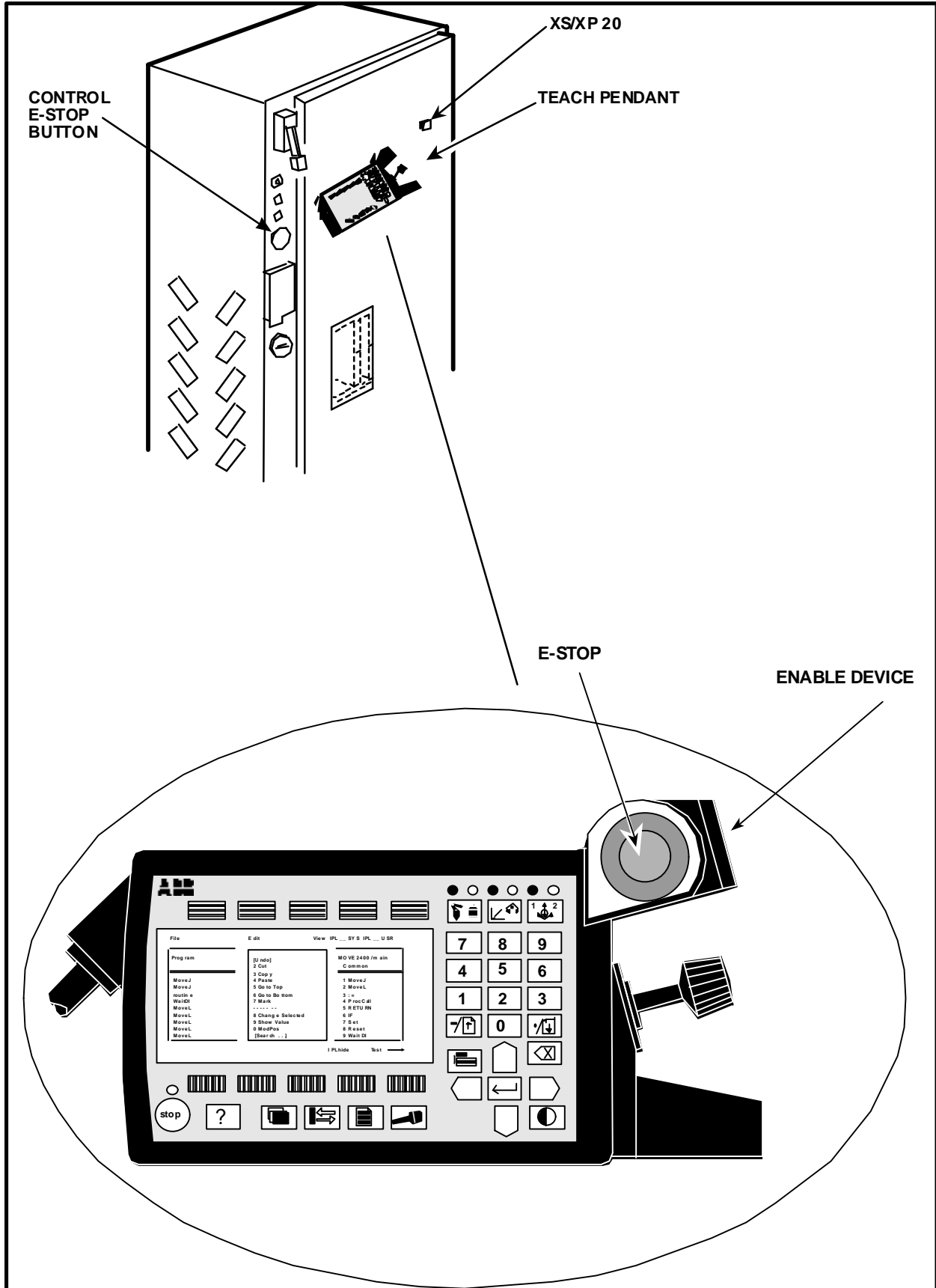

NOTES

Figure 6-2 Computer System & System Board

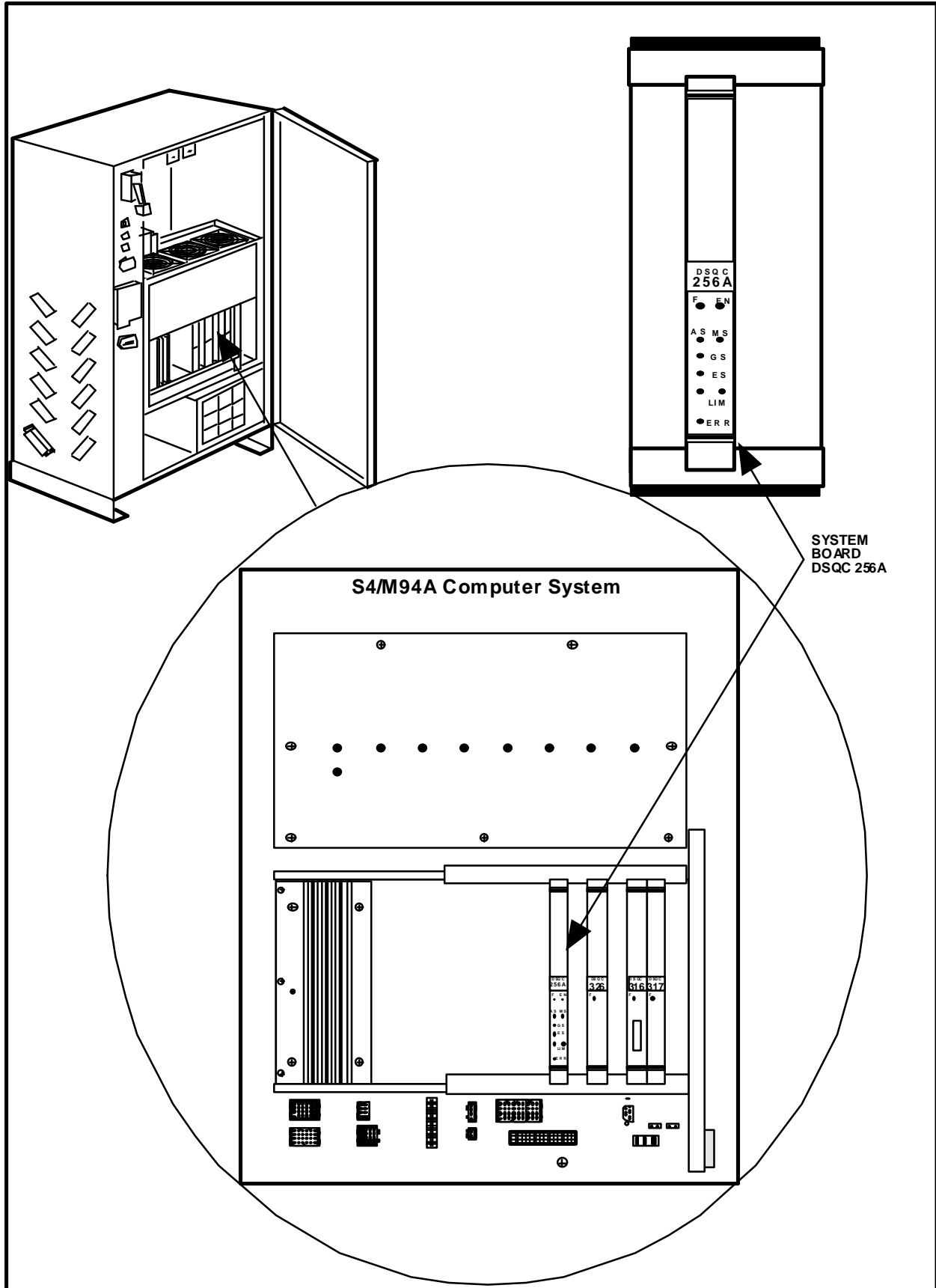

NOTES

Figure 6-3 Back Plane AP80

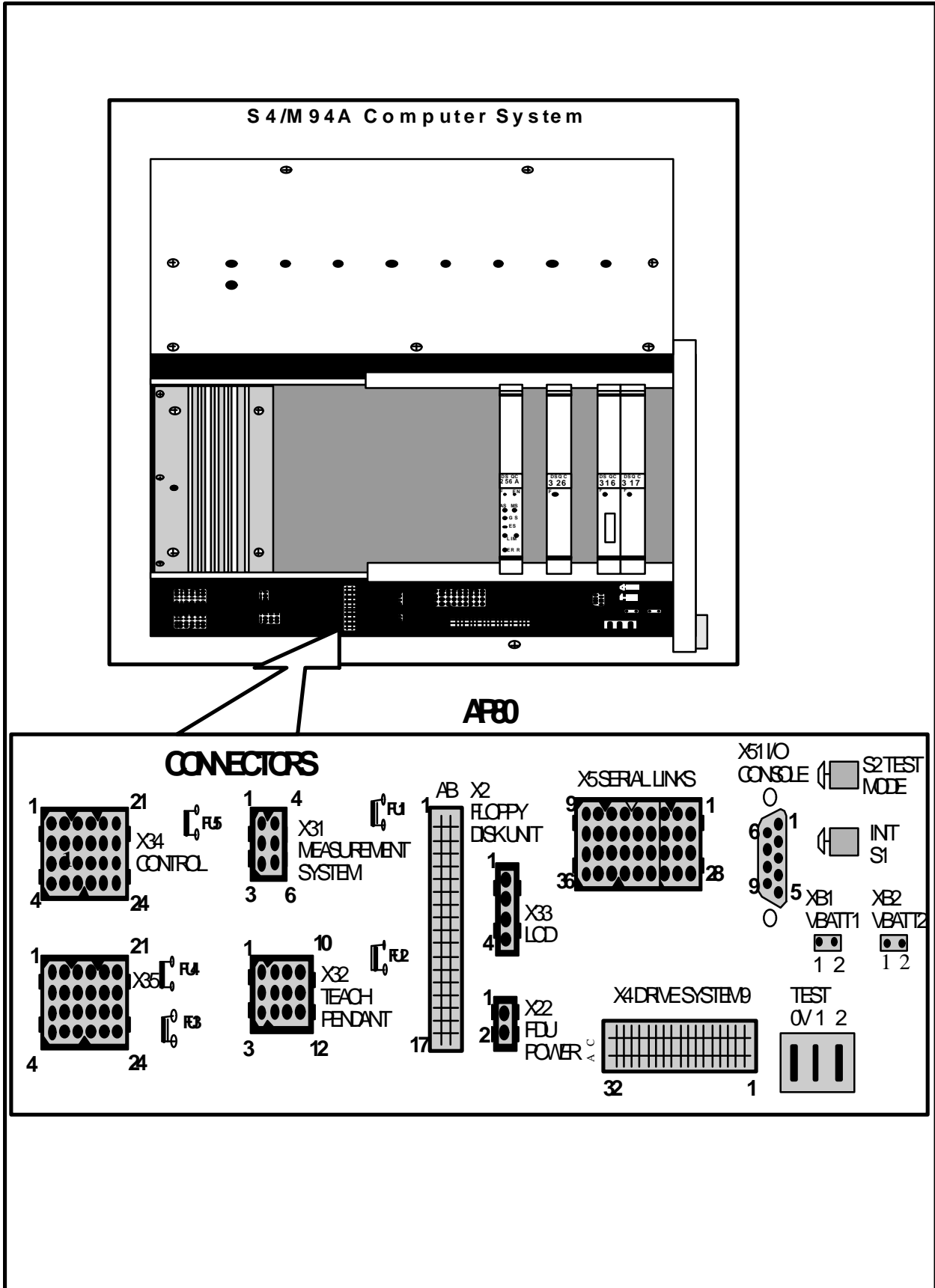

NOTES

Figure 6-4 Operator's Panel

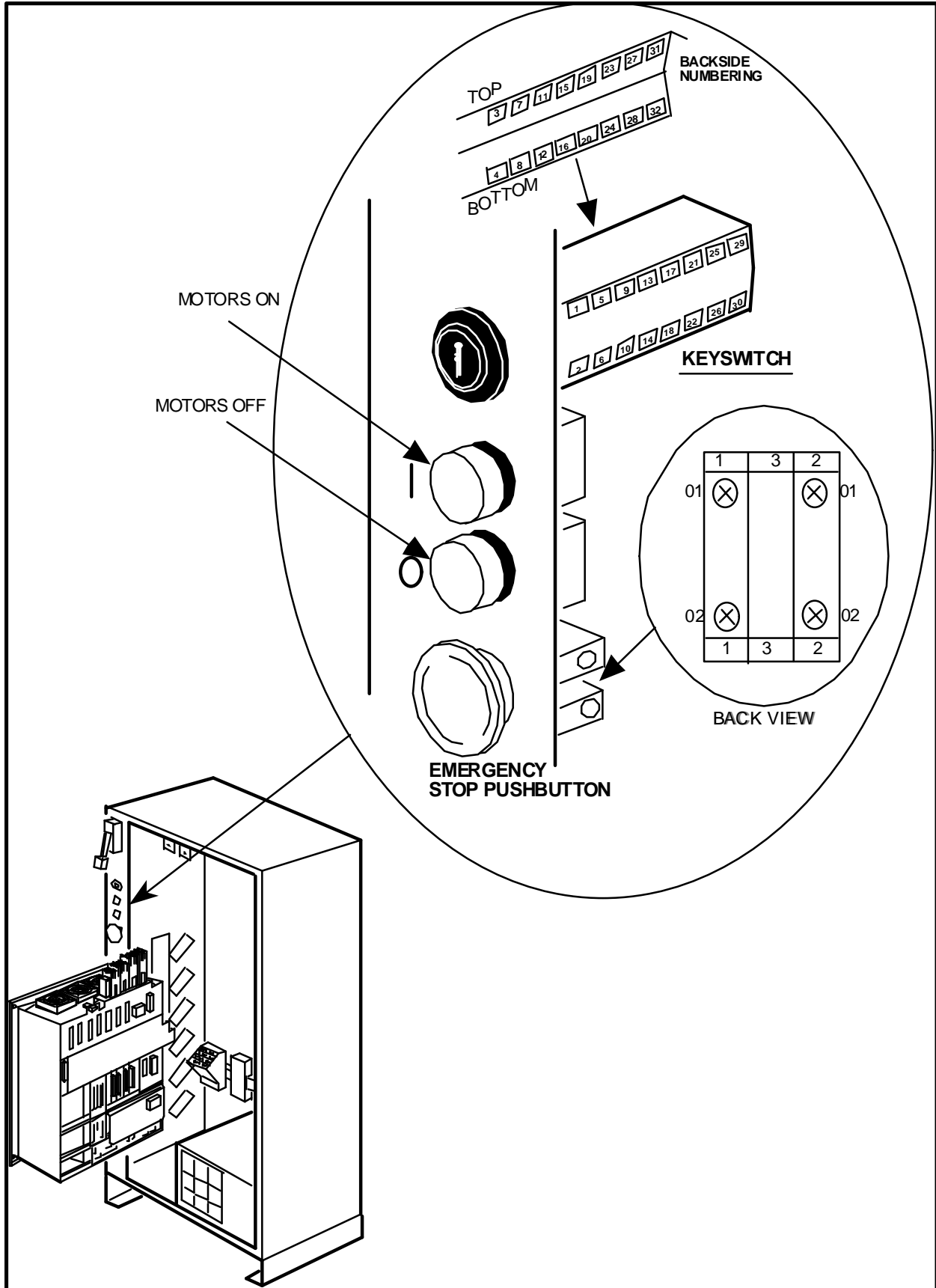

NOTES

Figure 6-5 Customer Connections XS3/XT3

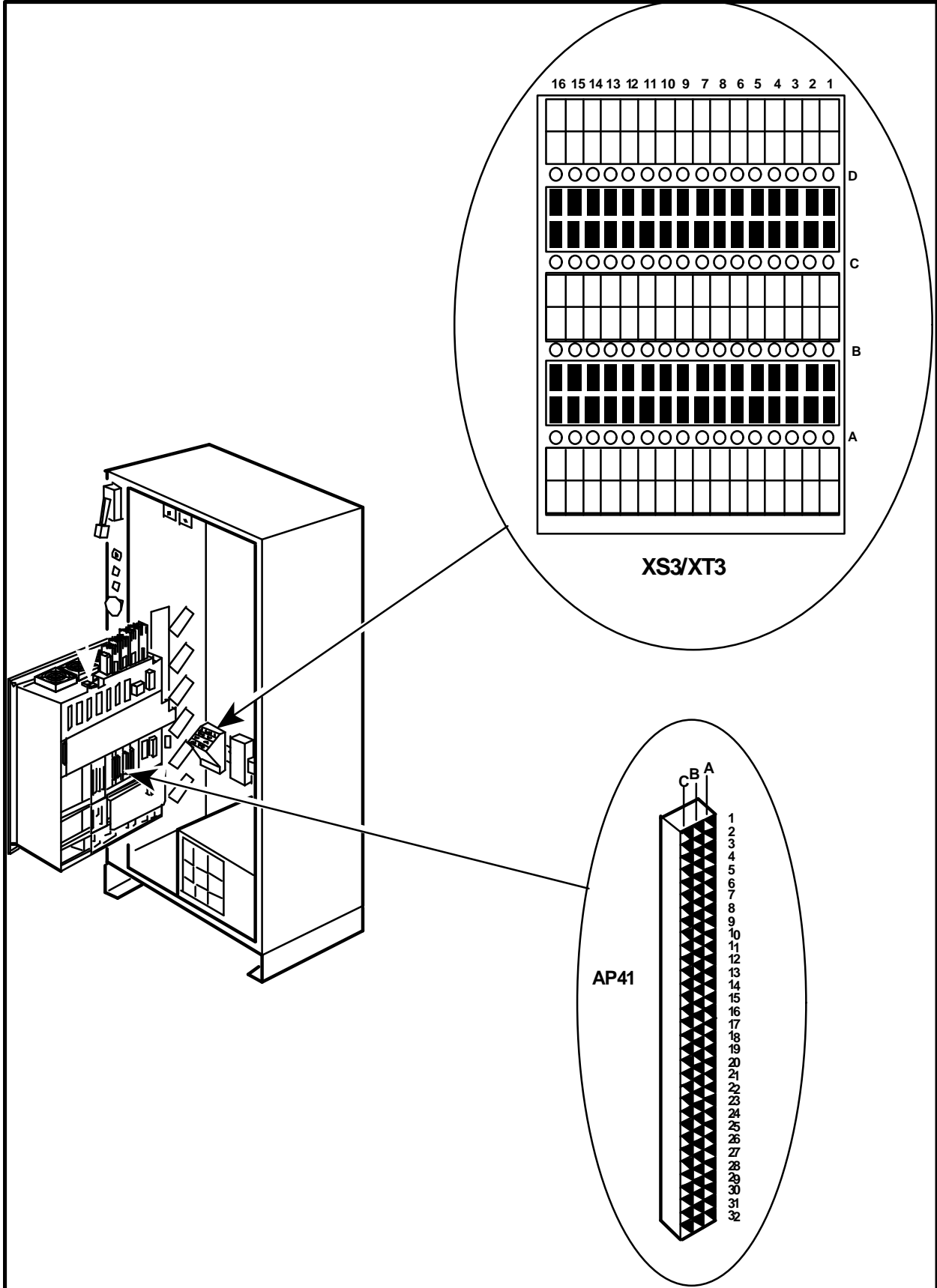

NOTES

CHAPTER 7

POWER UNIT CIRCUITRY

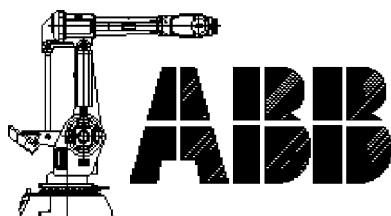

Power Unit Circuitry

Table of Contents

7.	Power Unit.....	7-3
7.1	Overview	7-3
7.2	KM1	7-4
7.3	KM2	7-5
7.4	KM3	7-6
	<i>Diagram 7-1 Rectifier Board</i>	<i>7-7</i>
7.5	KM4	7-8
7.6	Component Cross Reference	7-9
7.7	List of Circuit Diagrams	7-11
7.8	Component Location Figures	7-17
	Figure 7-1 Power Unit	7-17
	Figure 7-2 XS3/XT3 and Connectors AP41 & AP9.....	7-19
	Figure 7-3 K1CR & K2CR on System Board.....	7-21

NOTES

7. Power Unit

7.1 Overview

Fig. 7-1 ➡



The power unit is located on top of the swing gate and is made up of four 24 VDC relays made by ABB.

The four relays are:

- KM1 — Motors ON Relay 1
- KM2 — Motors ON Relay 2
- KM3 — Supervisory Relay
- KM4 — Brake Release Relay

The coils of all four relays have noise suppression devices (RV1-3 and V3) connected to the coil terminals A1 and A2. In this section we will explain the operation of these relays and wiring of the relays.

7.2 KM1

Sheet 9, line 08 
Fig. 7-1 

The KM1 Relay is the end of Run Chain 1.

If Run Chain 1 is closed and the computer has no faults, then 24 VDC will go through KM3 contacts to terminal A2. (A1 and A2 are the coil terminals of the KM relays.) The A1 terminal is connected to 0 VDC.



The KM1 relay has 6 sets of normally open contacts and 2 sets of normally closed contacts:

Sheet 9, line 07 

Normally OPEN contacts 44 and 43 are used to latch/bypass around KM3 relay contacts 33 and 34.

Sheet 9, line 08 

Normally OPEN contacts 7 and 8 are used along with KM2 and KM4 contacts to release the brakes on the robot.

Sheet 9, line 08 
Sheet 9, line 19 



Normally OPEN contacts 33 and 34 connected to XS3/XT3 terminals A13 and A14 are supplied for the customer to use to indicate when KM1 is energized.

Sheet 9, line 08 

Normally OPEN contacts 2, 4, 6, and 1, 3, 5 are the power contacts on KM1. 262 VAC is on contacts 2, 4, and 6 when the control is power up. When KM1 is energized power will go out contacts 1, 3 and 5 to KM2 contacts.



Sheet 9, line 08 

Normally CLOSED contacts 11 and 12 along with KM2 contacts are used to tell the system board that the KM1 relay is not energized.

Sheet 9, line 08 
Fig. 7-2 

Normally CLOSED contacts 21 and 22 are used to bypass the Motors Hold Off circuits on XS3/XT3 terminal C1 and C2.

7.3 KM2

Sheet 9, line 07 
 Fig. 7-1 

The KM2 relay is the end of Run Chain 2.

If Run Chain 2 is closed and the computer has no faults then 0 VDC will go through KM3 contacts to terminal A2. (A1 and A2 are the terminals of the coil of KM relays.) The A1 terminal is connected through the transformer temperature switch to 24 VDC. If the transformer gets too hot, the switch will open causing KM2 to de-energize.



The KM2 relay has 6 sets of normally open contacts and 2 sets of normally closed contacts:

Sheet 9, line 07 

Normally OPEN contacts 44 and 43 are used to latch/ bypass KM3 relay contacts 43 and 44.

Sheet 9, line 09 

Normally OPEN contacts 7 and 8 are used along with KM1 and KM4 contacts to release the brakes on the robot.

Sheet 9, line 10 
 Sheet 9, line 19 



Normally OPEN contacts 33 and 34 connected to XS3/XT3 terminals B13 and B14 are supplied for the customer to use to indicate when KM2 is energized.

Sheet 9, line 10 

Normally OPEN contacts 1, 3, 5, and 2, 4, 6 are the power contacts on KM2. 262 VAC is on contacts 1, 3, and 5 when KM1 is energized. When KM2 is energized, 262 VAC will go out contacts 2, 4, and 6 then to the drive system.



Sheet 9, line 09 

Normally CLOSED contacts 11 and 12 along with KM1 contacts are used to tell the system board that the KM relays are not energized.

Sheet 9, line 09 
 Fig. 7-2 

Normally CLOSED contacts 21 and 22 are used to bypass the Motors Hold Off circuits on XS3/XT3 terminal C1 and C2.

7.4 KM3

Sheet 9, line 04 
Fig. 7-1 

The KM3 relay is thought of as a motors off relay, because it is only energized when the motors are OFF.



If it is not energized when trying to start the motors, KM1 and KM2 will not pull in, preventing power from getting to the drive system.

KM3 should be energized when the main disconnect is turned on.

Sheet 9, line 10 



- 24 VDC goes through KM2 normally closed contacts 12 and 11.

Sheet 9, line 08 

- Then through KM1 normally closed contacts 12 and 11.

Sheet 9, line 04 

- Then 24 VDC goes through KM4 normally closed contacts 21 and 22.
- To XS3/XT3 terminal C1.

Sheet 9, line 01 
Fig. 7-2 

Between C1 and C2 is a place for the customer to wire into the motors hold off circuit.



This circuit can only be used to keep the motors OFF, if they are already OFF. KM3 must be de-energized before motors are shut OFF. This circuit will NOT stop the motors. This circuit is usually used with the system input "HOLD".

If this circuit is not used then a jumper is required between XS3/XT3 terminals C1 to C2.



Sheet 9, line 06 

24 VDC will then go to KM3 terminal A1 causing KM3 to energize. It is important to note that KM3 will not energize unless the circuit between XS3/XT3 terminals D1 and D2 is closed. This connects A2 to 0 VDC.

Sheet 9, line 01 

If this circuit is not being used then a jumper is required between D1 and D2.

KM3 (Cont)

Sheet 9, line 05 
 Fig. 7-1 

Sheet 9, line 06 

Sheet 9, line 05 

Sheet 9, line 04 

Sheet 9, line 04 

Sheet 9, line 04 

Sheet 9, line 05 

Sheet 12, line 12 

The KM3 relay has four sets of normally open contacts and four sets of normally closed contacts:

Normally OPEN contacts 53 and 54 are used to bypass XS3/XT3 terminals D1 and D2 so the customer no longer has control of KM3 on the 0 VDC side.

Normally OPEN contacts 13 and 14 bypass XS3/XT3 terminals C1 and C2 so the customer no longer has control of KM3 on the 24 VDC side. Then bypasses KM4 contacts 21 and 22. 24 VDC now goes through KM1 Normally closed contacts 21 and 22 and KM2 normally closed contacts 21 and 22, keeping KM3 energized.

Normally OPEN contacts 33 and 34 are used to allow KM1 to be energized.

Normally OPEN contacts 43 and 44 are used to allow KM2 to be energized.

Normally CLOSED contacts 21 and 22 are used to allow KM4 (the brake relay) to energize only when KM3 is not energized.







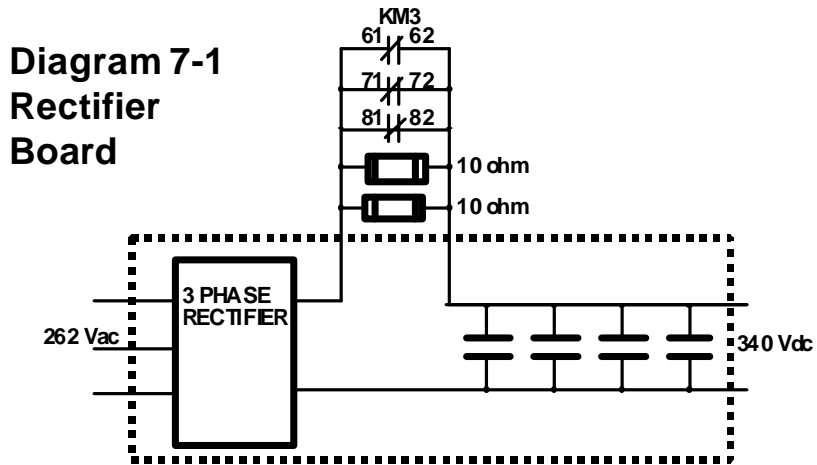









Normally CLOSED contacts 62, 72, 82 and 61, 71, 81 are used for only that instant when KM1 and KM2 are energized and KM3 has not yet de-energized, to supply a load for the drive system rectifier. This is to eliminate a high inrush of current through its capacitors. *If this circuit is not working properly serious damage to drive rectifier and drive boards could result.*



The diagram below shows how these contacts work with the Drive Rectifier.



7.5 KM4

Sheet 8, line 16 	The KM4 relay is used to release the robot axis brakes.
Fig. 7-1 	
Fig. 7-2 	
Fig. 7-3 	
Sheet 9, line 13 	
Fig. 7-2 	
Sheet 9, line 13 	<ul style="list-style-type: none">- 24 VDC goes to KM4 terminal A1 energizing KM4.- The 24 VDC on terminal A1 also goes through diode V1 to the hour meter pin 'N'. This starts the meter timing.
Sheet 5, line 18 	<p>It is important to note that the 0 VDC on KM4 terminal A2 goes through FS1 (Drive Power Circuit Breaker) and then to 0 VDC. That way if FS1 is tripped then the brakes will not release.</p> <p>KM 4 has four sets of normally open contacts and two sets of normally closed contacts.</p> <p>Normally OPEN contacts 1 and 2 go to XS3/XT3 terminals C10 and C11 are supplied for the customer to use to monitor the robots brake circuits.</p> <p>Normally OPEN contacts 3 and 4 along with KM1 and KM2 contacts send 24 VDC to the brakes, to release the brakes.</p> <p>Normally OPEN contacts 5 and 6 along with KM1 and KM2 contacts could be used to release external axis brakes.</p> <p>Normally OPEN contacts 33 and 34 are used to enable the Axis 1 blower motor if this option exists in the system.</p> <p>Normally CLOSED contacts 21 and 22 are used to disable KM3 when KM4 is energized.</p> <p>Normally CLOSED contacts 51 and 52 are used to disable the brake push buttons.</p>
Sheet 9, line 13 	
Sheet 8, line 18 	
Fig. 7-1 	
Sheet 9, line 13 	
Sheet 9, line 13 	
Sheet 9, line 13 	
Sheet 9, line 04 	
Sheet 9, line 13 	

7.6 Component Cross Reference

Component Name	Component Location	Circuit Diagram Number	Location Figure
Power unit	Swing gate, top	Sheet 9	7-1
KM1	Power unit	Sheet 9	7-1
KM2	Power unit	Sheet 9	7-1
KM3	Power unit	Sheet 9	7-1
KM4	Power unit	Sheet 9	7-1
System board AP41	Swing gate, front	sheet 8	7-2
XS3/XT3	Cabinet, back	Sheet 8	7-2
Drive system AP1	Swing gate, upper	Sheet 12	7-3

NOTES

7.7 List of Circuit Diagrams

1.	MAINS CONNECTION	5 of 43
2.	MOTOR ON CHAIN PART 2	8 of 43
3.	POWER UNIT	9 of 43
4.	6400 DRIVE SYSTEM	12 of 43

NOTES

Figure 7-1 Power Unit

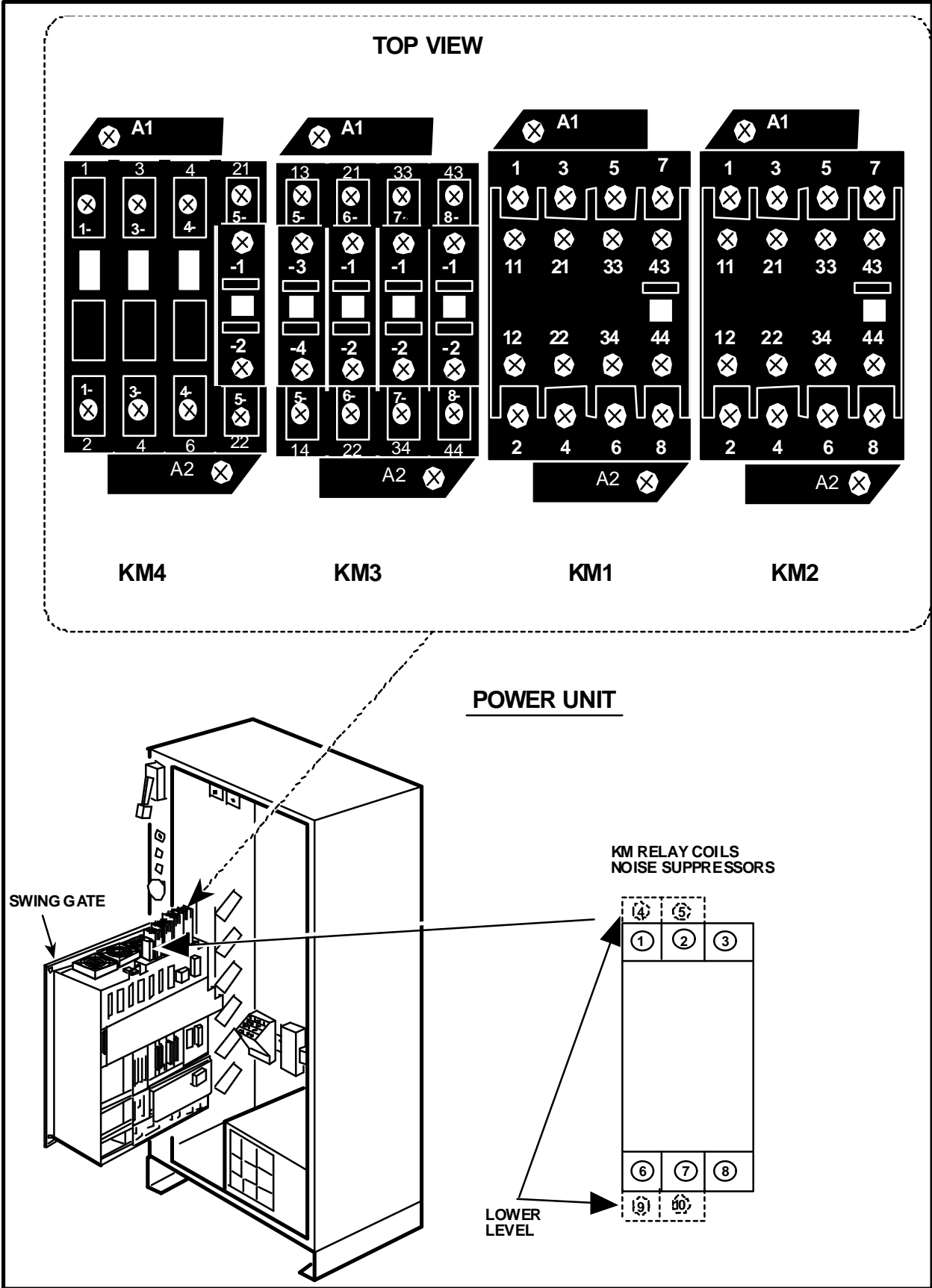

NOTES

Figure 7-2 XS3/XT3 and Connectors AP41 & AP9

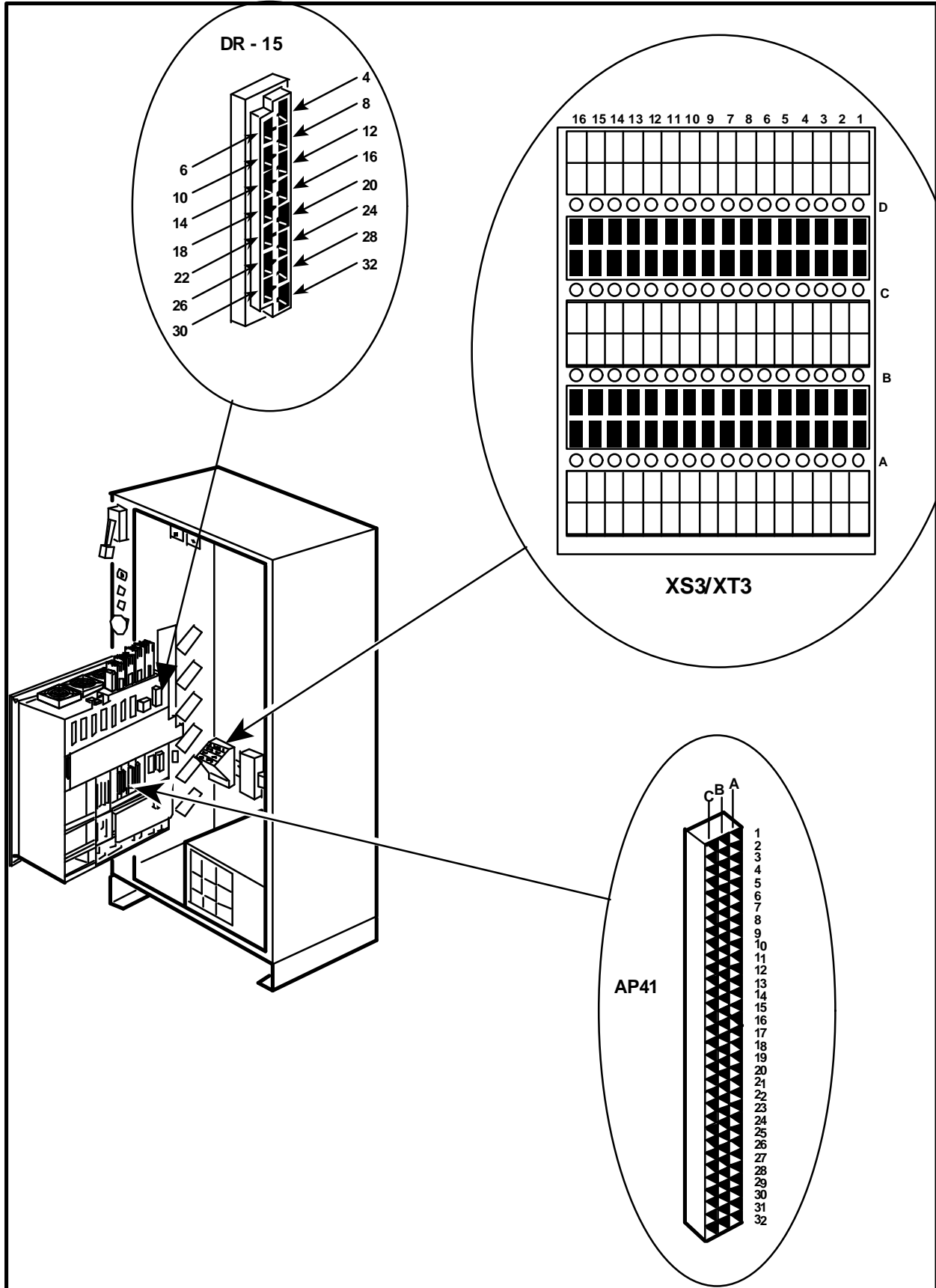

NOTES

Figure 7-3 K1CR & K2CR on System Board

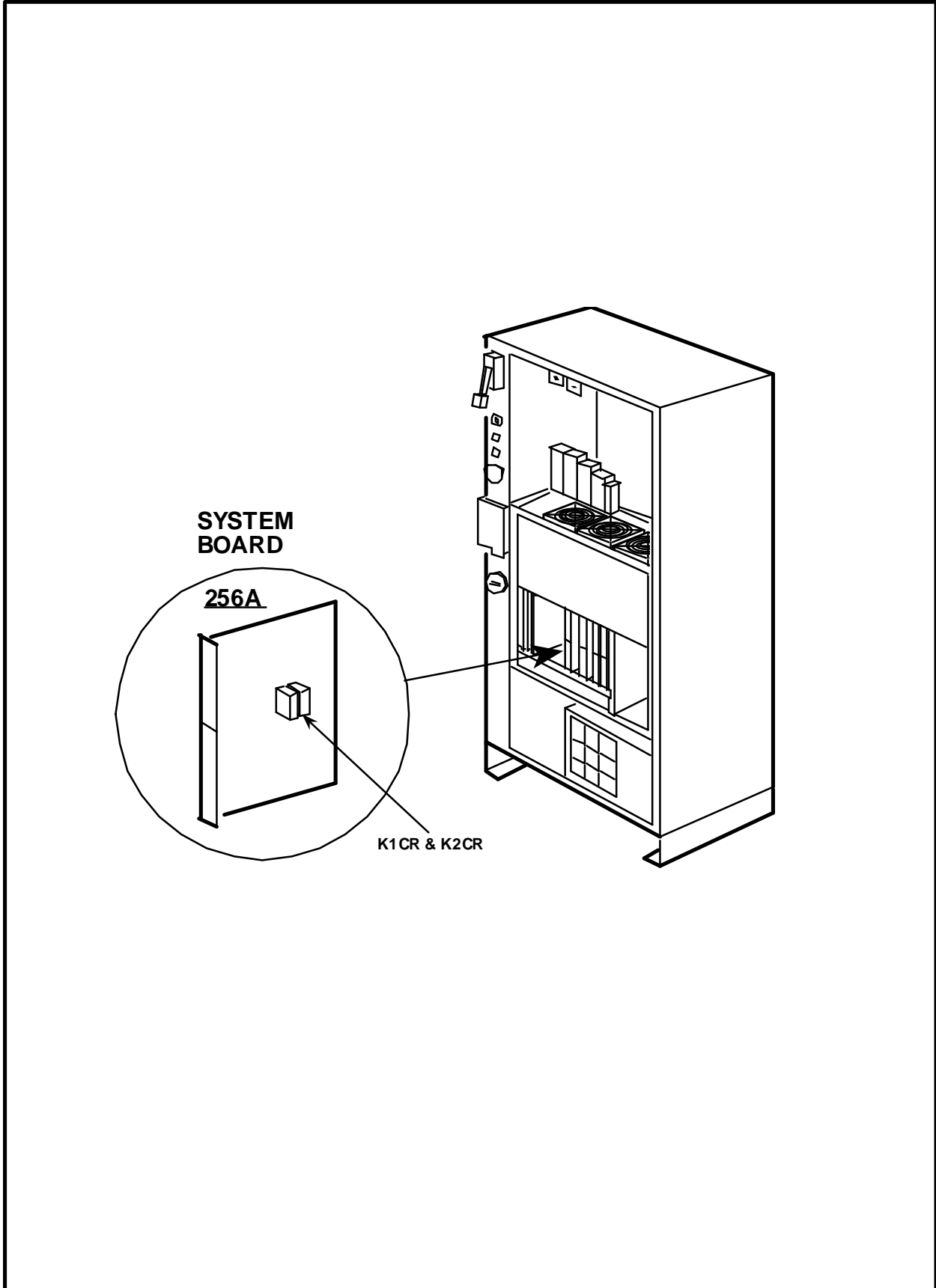

NOTES

CHAPTER 8

BRAKE CIRCUITRY



Brake Circuitry

Table of Contents

8.	Brake Circuitry	8-3
8.1	Overview	8-3
8.2	Manual Brake Release Circuit	8-4
8.3	Motors ON Brake Release	8-5
8.4	Component Cross Reference	8-7
8.5	List of Circuit Diagrams	8-9
8.6	Component Location Figures	8-23
	Figure 8-1 Power Unit	8-23
	Figure 8-2 System Board	8-25
	Figure 8-3 Robot Brake Buttons.....	8-27
	Figure 8-4 Power System Board Connections.....	8-29
	Figure 8-5 Robot Axes	8-31

NOTES

8. Brake Circuitry

8.1 Overview

Fig. 8-5 ➡

The IRB 6400 robot has an axis brake for each axis motor (1-6). The brake is part of the motor and can not be replaced separately from the motor. The brake is only a holding brake used to hold the robot in position when the motors are off. When the brake is de-energized, heavy duty springs inside the brake hold metal plates against brake material holding the motor in position. The brakes are released by applying 24 VDC to the coil of the brake. The robot motors can override the brakes for a while until the motor overheats due to the extra load caused by the brake.

If an axis brake is slipping it will only cause a problem when the motors are off because the axis will drift to its hard stop. *The normal cause of a brake slipping is oil getting into the brake pads due to a seal that has failed.*

Sheet 104-110.....
Fig. 8-3



To test a brake for proper operation turn on the main disconnect and press the manual release button on the robot to see if the brake releases. If further testing is required, check the wiring to the brake and the brake coil resistance. The normal brake resistance should be approximately 15-30 ohms.





USE EXTREME CAUTION WHEN MANUALLY RELEASING BRAKES. ROBOT MAY FALL OR RISE UNEXPECTEDLY CAUSING PERSONAL INJURY OR TOOLING DAMAGE!!

In this chapter we will trace the circuits used for the brake release circuits. There will be two sections, one for Manual Brake Release circuits and one for Motors ON Brake Release circuits.

8.2 Manual Brake Release Circuit

The **Manual Brake Release** circuit:

Sheet 6, line 10 
Fig. 8-1,4 

- Begins at the power supply GS1 pin D16.
- **24 VDC** (known as Brake PB) goes to the power unit's KM4 relay terminal 51.



Sheet 9, line 12 

Contacts 51 and 52 of KM4 are normally closed contacts that prevent the use of manual brake release buttons when the brake relay KM4 is energized.

As long as KM4 is NOT energized:

Sheet 13.1, line 11..... 

- **24 VDC** goes through terminal 52 to XS/XP1 pin B16.

Sheet 105, line 10..... 
Fig. 8-3 

- Into R1.MP pin B16.

Sheet 104, line 01..... 



- Out to the brake unit (located on the robot's right side.)
- 24 VDC goes through the cable labeled R3.BU1-6 on the brake unit to R3.X8 pin 5.
- 24 VDC is then distributed to each of the six axis brake switches mounted on the brake unit.

When a brake button is pressed:



Sheet 105-110..... 

- 24 VDC will go to the individual axis brake coil.

For example Axis 1:

Sheet 104, line 09..... 
Sheet 105, line 06..... 

- 24 VDC would go through R3.X9 pin 10.
- Into the Axis 1 motor connector R2.MP1 pin L.
- Inside the motor the 24 VDC will energize the coil of the brake, releasing the brake pads allowing the motor to turn freely.

Sheet 105, line 11..... 
Fig. 8-3 

Each individual axis brake works similarly to Axis 1.



If the brakes need to be released before the Control Cabinet is connected to the robot, use a 24 VDC power source connected to R1.MP pin B16 and 0 VDC to R1.MP pin B15. Then use the brake release push buttons on the robots right side.



USE EXTREME CAUTION WHEN MANUALLY RELEASING BRAKES. ROBOT MAY FALL OR RISE UNEXPECTEDLY CAUSING PERSONAL INJURY OR TOOLING DAMAGE!!

8.3 Motors ON Brake Release

When the motors are started, the brakes will not release until the joystick on the teach pendant is moved or the program commands movement.

Fig. 8-1 ➡



Remember that when the robot has been in the same position for 3 minutes without movement, the computer will de-energize the KM4 relay causing the brakes to reengage. This time can be changed by pressing;

MISC
SYSTEM PARAMETER
MANIPULATORS

This is done to conserve power consumption and to save on motor life by having the brakes hold the robot in position and allowing the motors to relax. As soon as the computer receives a command for motion, it will release the brakes by energizing KM4 again.

Fig. 8-2 ➡

The brakes are controlled on the System board (DSQC 265A) by relay K3. When the computer energizes K3 relay:

- Sheet 8, line 16 ➡
- Fig. 8-4 ➡
- Sheet 9, line 04 ➡
- Fig. 8-1 ➡
- Sheet 9, line 13 ➡
- Sheet 5, line 16 ➡
- Fig. 8-4 ➡

- The contacts on K3 close allowing 24 VDC to go through AP41.XP1 pin C30.
- The 24 VDC then goes through KM3 (normally closed) contacts 21 and 22.
- To the KM4 relay terminal A1.
- KM4 relay will energize as long as circuit breaker FS1 has not opened.

Motors ON Brake Release (Cont)

Fig. 8-1	►	The KM4 relay has four sets of normally open contacts and two sets of normally closed contacts on it.
Sheet 9, line 13	✎	Normally OPEN contacts 1 and 2 are supplied for customer use on XS3/XT3 terminals C10 and C11.
Sheet 9, line 13	✎	Normally CLOSED contacts 51 and 52 when opened disable the brake push buttons.
Sheet 9, line 13	✎	Normally OPEN contacts 5 and 6 can be used to release external axes (axes 7-12) brakes, if applicable.
Sheet 9, line 13	✎	Normally OPEN contacts 33 and 34 can be used to control a blower fan in Axis 1, if applicable.
Sheet 9, line 04	✎	Normally CLOSED contacts 21 and 22 are used to disable the KM3 relay when KM4 is energized.
Fig. 7-1	►	
Sheet 9, line 13	✎	Normally OPEN contacts 3 and 4 (which along with KM1 and KM2 contacts 7 & 8):
Sheet 13.1, line 14.....	✎	<ul style="list-style-type: none">- Sends 24 VDC to XS1 pins B12 and B13.- From there, 24 VDC goes to R1.MP pins B12 and B13.- To the brake unit R3.X8 pins 1 and 2.- Once on the brake unit, the 24 VDC goes through normally closed contacts on each individual axis brake release push buttons.- Then to each individual axis brake.
Fig. 8-3	►	
Sheet 105, line 11.....	✎	
Sheet 104, line 01.....	✎	
Fig. 8-5	►	
Sheet 104, line 09.....	✎	For example:
Sheet 105, line 06.....	✎	<ul style="list-style-type: none">- For Axis 1, 24 VDC would go out R3.X9 pin 10 and then to the motor connector R2.MP1 pin L. Then to the brake coil. The other side of the coil would return to 0 VDC. The other axes would work similarly.

8.4 Component Cross Reference

Component Name	Component Location	Circuit Diagram Number	Location Figure
System board AP41.XP1	Swing gate	Sheet 8	8-4
Power supply GS1.XP1	Swing gate	Sheet 6	8-4
Power unit	Swing gate, top	Sheet 9	8-1
KM1	Power unit	Sheet 9	8-1
KM2	Power unit	Sheet 9	8-1
KM3	Power unit	Sheet 9	8-1
KM4	Power unit	Sheet 9	8-1
XS1XP1	Cabinet, left side	Sheet 13.1	8-4
R1.MP	Robot, back	Sheet 13.1, 105	8-3
Brake unit	Robot, right side	Sheet 104	8-3
R3.X8, R3.X9, R3.X10	Robot, right side	Sheet 104	8-3
R2.MP1, R3.MP2, R3.MP3, R3.MP4, R4.MP5, R4.MP6,	Robot	Sheets 105, 106, 107,108,109,110	8-5
K3CR	System Board	Sheet 9	8-2

NOTES

8.5 List of Circuit Diagrams

1.	MAINS CONNECTION	5 of 43
2.	POWER SUPPLY +24 VDC, +5VDC	6 of 43
3.	MOTOR ON CHAIN PART 2	8 of 43
4.	POWER UNIT	9 of 43
5.	BRAKE UNIT SERIAL MEAS. BOARD	104 of 12
6.	AXIS 1	105 of 12
7.	AXIS 2	106 of 12
8.	AXIS 3	107 of 12
9.	AXIS 4	108 of 12
10.	AXIS 5	109 of 12
11.	AXIS 6	110 of 12

NOTES

Figure 8-1 Power Unit

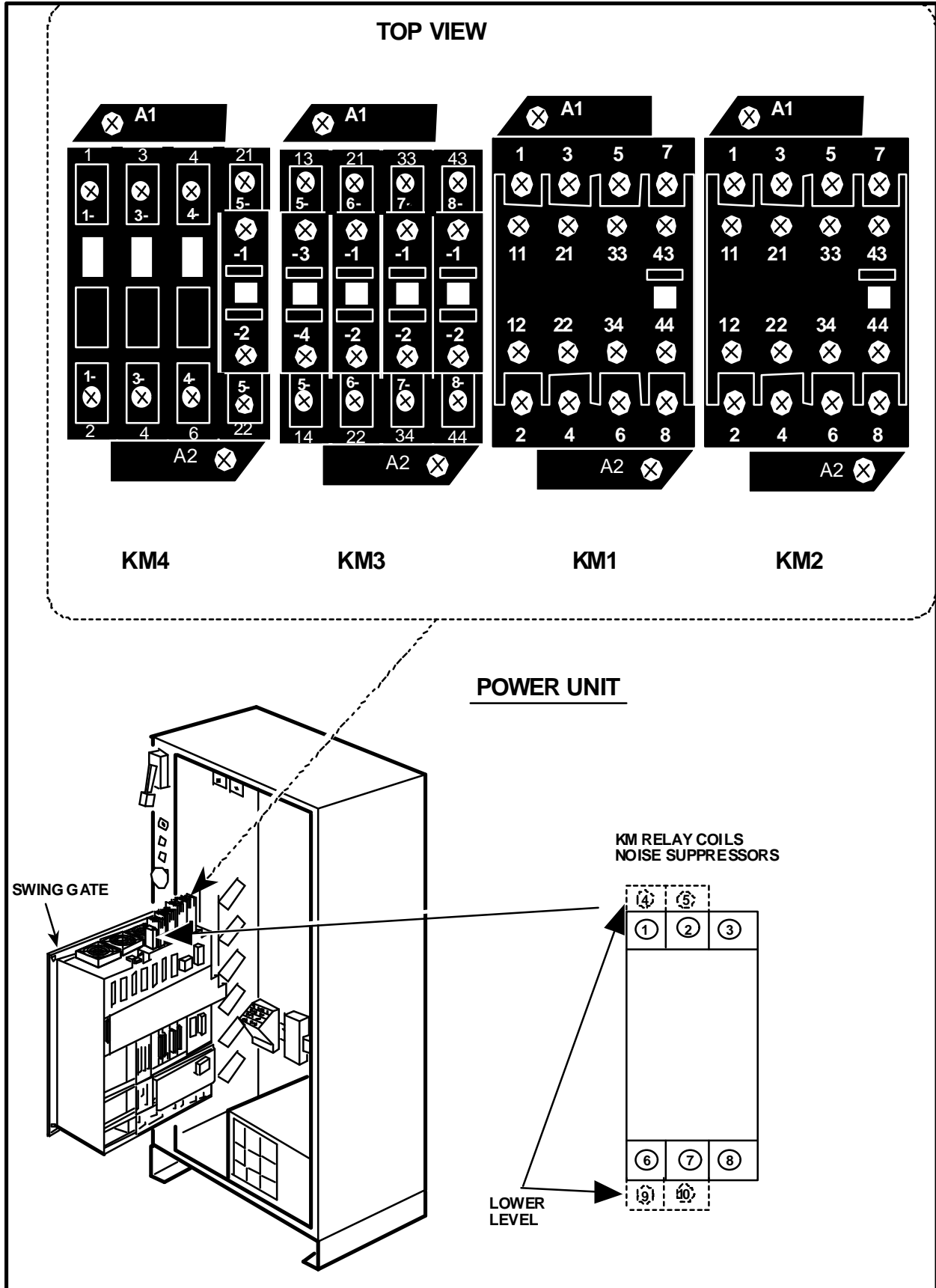

NOTES

Figure 8-2 System Board

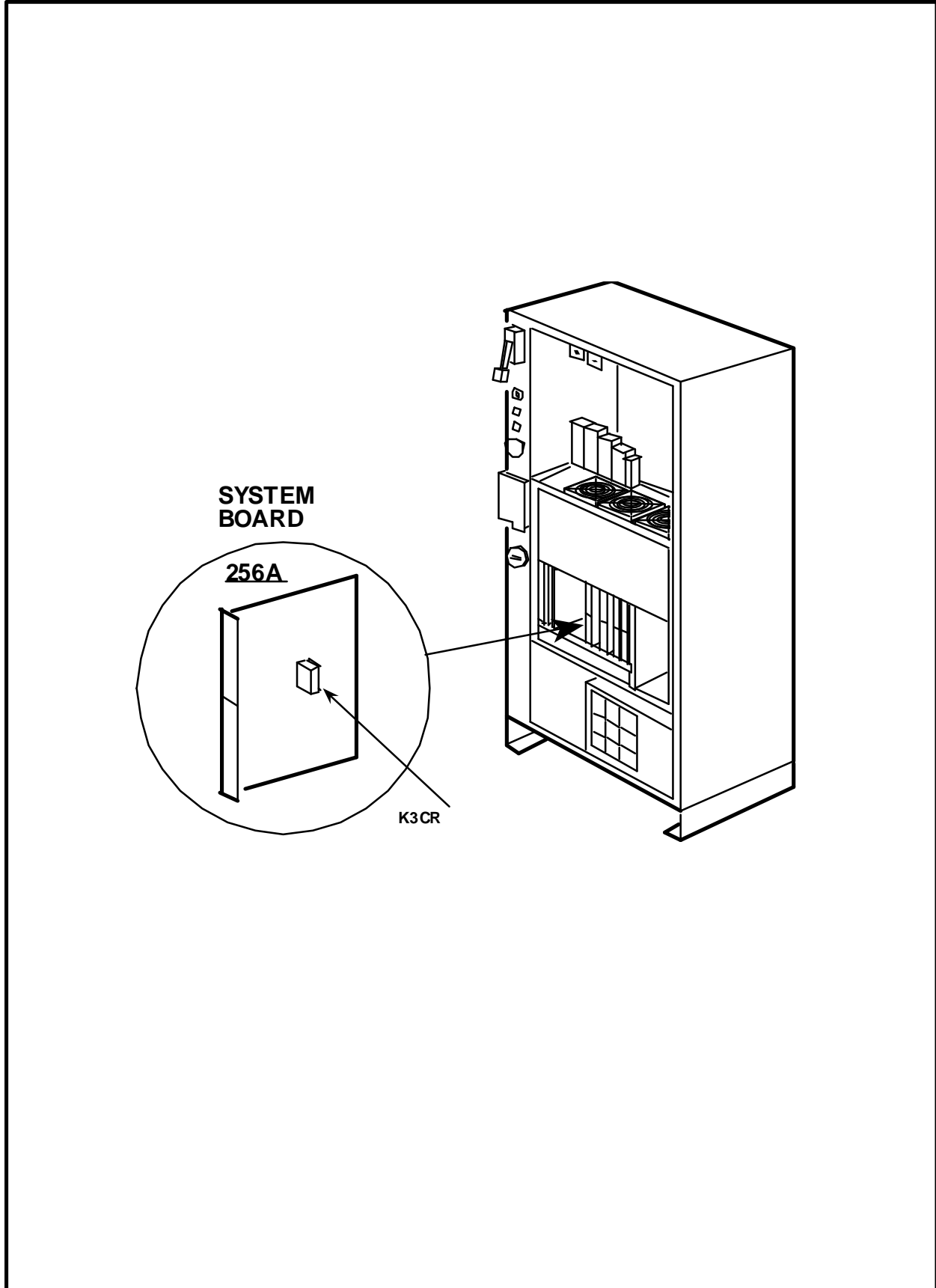

NOTES

Figure 8-3 Robot Brake Buttons

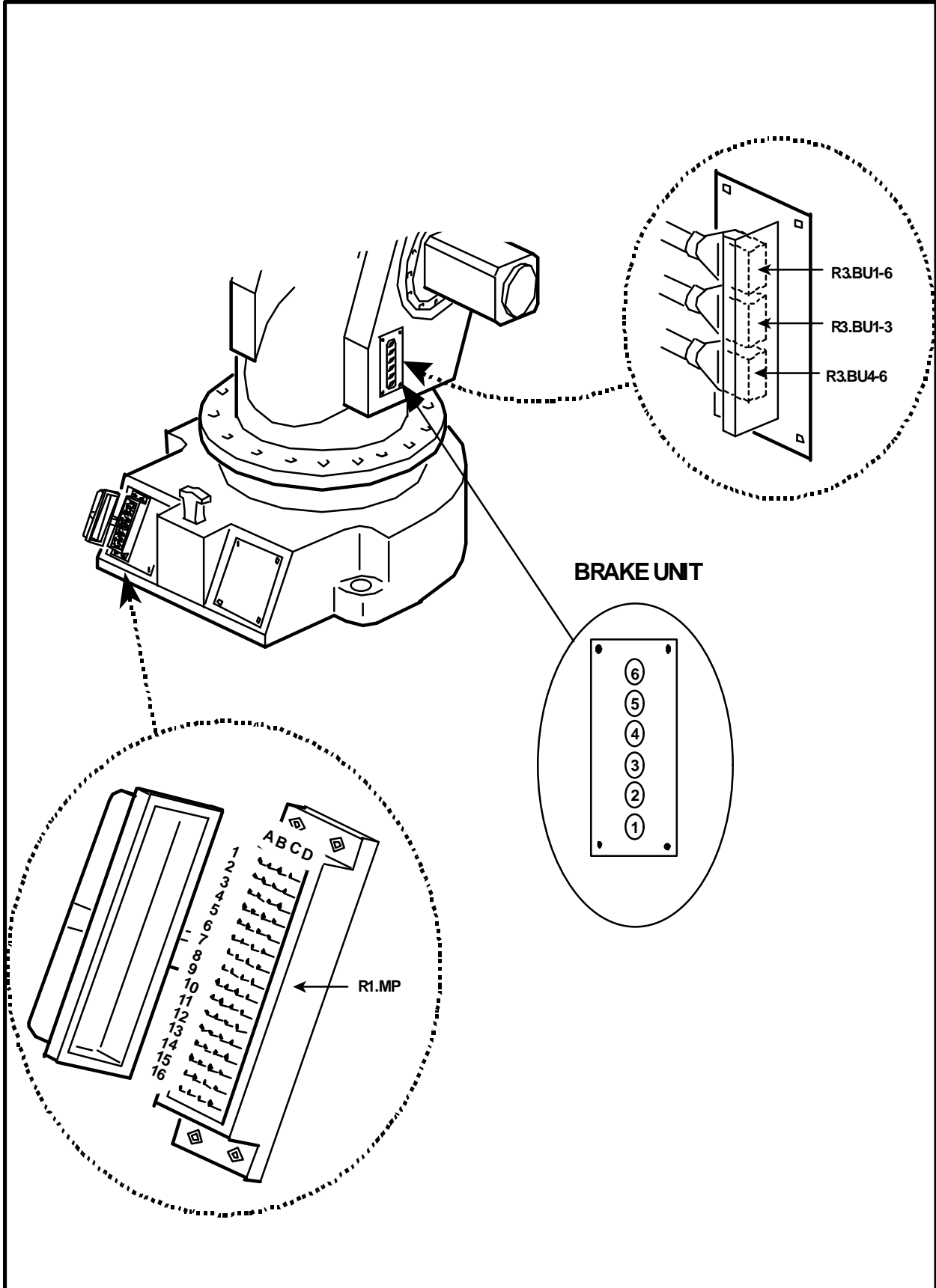

NOTES

Figure 8-4 Power System Board Connections

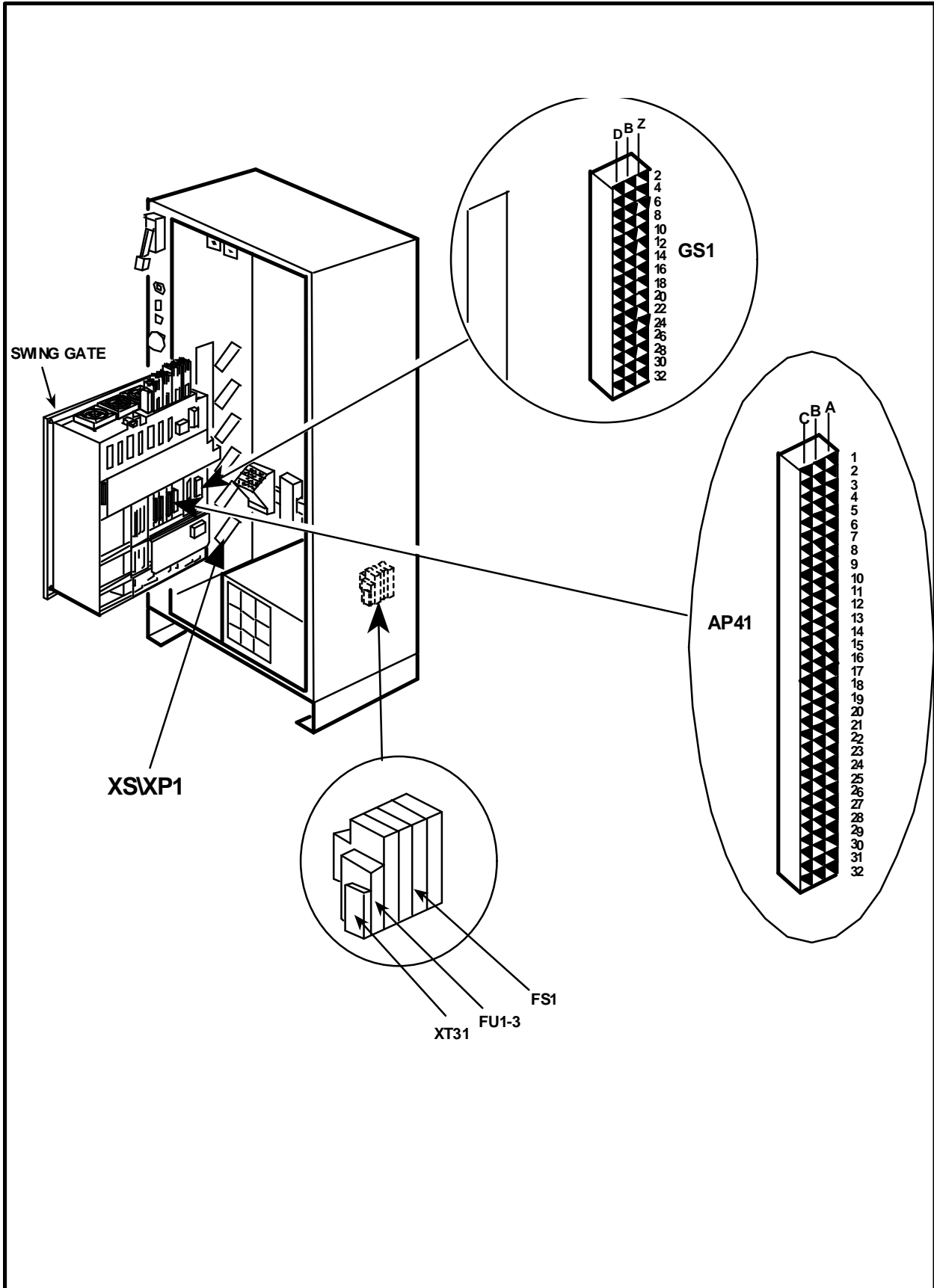

NOTES

Figure 8-5 Robot Axes

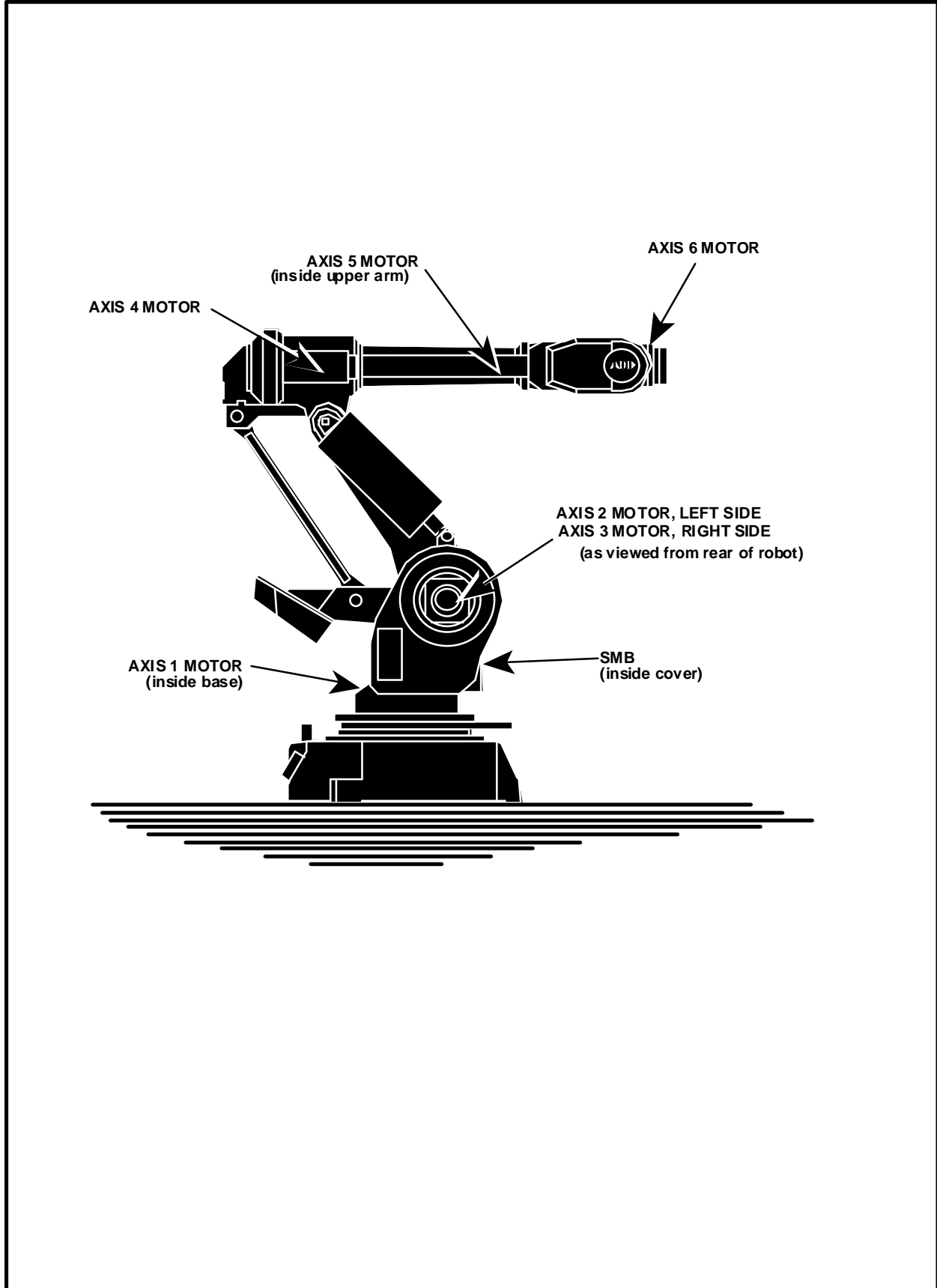

NOTES

CHAPTER 9

MOTOR & RESOLVER CIRCUITRY

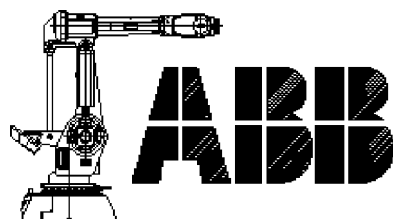

Motor & Resolver Circuitry

Table of Contents

9.	Motor & Resolver Circuitry	9-3
9.1	Overview	9-3
	<i>Diagram 9-1 Closed Loop System</i>	<i>9-3</i>
9.2	Computer	9-4
9.2.1	Main Computer.....	9-4
9.2.2	Memory Board.....	9-4
9.2.3	Robot Computer.....	9-5
9.3	Drive System Boards	9-6
9.3.1	Rectifier.....	9-6
	<i>Diagram 9-2 Rectifier</i>	<i>9-6</i>
9.3.2	Drive Unit	9-8
	<i>Diagram 9-3 Drive Board</i>	<i>9-8</i>
9.4	Motors	9-9
	<i>Diagram 9-4 Simplified Motor</i>	<i>9-9</i>
	<i>Diagram 9-5 'Y' Motor Wiring Configuration</i>	<i>9-10</i>
9.5	Resolver	9-12
	<i>Diagram 9-6 Resolver Coil Relationships</i>	<i>9-12</i>
9.6	Serial Measurement Board (SMB)	9-13
9.7	Component Cross Reference	9-15
9.8	List of Circuit Diagrams	9-17
9.9	Component Location Figures	9-31
	Figure 9-1 Back Plane AP80	9-31
	Figure 9-2 Drive System Boards	9-33
	Figure 9-3 Robot Axis Motors.....	9-35
	Figure 9-4 Drive Connectors	9-37

NOTES

9. Motor & Resolver Circuitry

9.1 Overview

This chapter will explain:

- the major components of the Servo system.
- how each component works.
- how the various components interact.
- how to troubleshoot each component.
- what to do when a component is replaced.

The servo system is a complex system comprised of computer boards, software, and resolvers along with a PWM drive system connected to motors. The diagram below shows these components.

Diagram 9-1 Closed Loop System

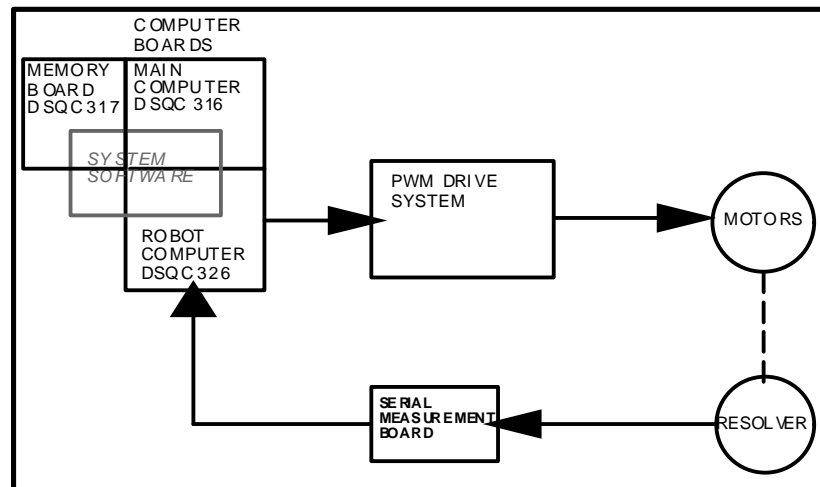

This type of servo system is known as a closed loop system because a movement command goes out the robot computer board to the drive system then to the motors. Connected to each motor is a resolver which is used for position feedback. These signals go through the serial measurement board which converts the analog resolver signals to a digital serial communication which is sent back to the robot computer. If any component in this loop is disconnected or fails, the system will generate a fault.

9.2 Computer

The computer section of this loop is made up of three boards:

- 1) Main Computer Board
- 2) Memory Board
- 3) Robot Computer Board

9.2.1 Main Computer

Fig. 9-1 ➡

The **Main Computer Board** (DSQC 316) generates what is known as a “pose”. A pose is the planned motions that the robot is to execute. Taken into account in a pose is the robot's position, the load of the tooling, the tooling length and orientation, the effects of gravity and inertia, and other such data required to get peak performance from the drive system. The pose is generated by the customers program or by moving the joystick. The computers software and the customers parameters determines the exact calculations for creating a pose. The main computer will send a commanded (move to) position to the robot computer board through the computer back plane.



Troubleshooting of the Main Computer Board can be difficult. Refer to Chapter 2 - Computer System for trouble shooting procedures.

9.2.2 Memory Board

The **Memory Board** (DSQC 317 or 321) is an extension of the main computers memory. It is used to store information used by the main computer.



Troubleshooting of the Memory Board can be difficult. Refer to Chapter 2 - Computer System for trouble shooting procedures.

9.2.3 Robot Computer

Fig. 9-1 ➡

Fig. 9-4 ➡

The **Robot Computer** (DSQC 326) will compare the commanded position from the main computer with the actual position (the actual position is found by use of the resolvers). If there is a difference between the actual and the commanded position, a signal will be sent through the ribbon cable to the drive system. The Drive system will move the motors to make the actual position match the commanded position.

When the robot is not moving, there is no signal being sent to the drive system other than a signal to hold the motor in position.

When the computer is executing a move in the program, the command will change causing the robot computer to send a signal to the drive system to make the motors move to the commanded positions.

If the commanded position differs from the actual position more than the allowed amount (determined by the software and speed), the robot computer will shut the system down and generate an error.

The signals sent from the robot computer to the Drive system are sent in pairs of two for each axis. These signals are sent through a 64 conductor ribbon cable. The two phases are known as 'R' and 'S' phases. These two of the three phases are needed by the motor. The third phase is calculated by the Drive unit.



Troubleshooting of the Robot Computer can be difficult. Refer to Chapter 2 - Computer System for trouble shooting procedures.

9.3 Drive System Boards

The **Drive System** is a PWM (pulse width modulated) drive. The components of the drive system consists of a back plane, a drive rectifier (DC-Link) and six axes drive boards (one for each axis).

9.3.1 Rectifier

The **Rectifier** (also known as DC-Link) is the drive power supply. Its main purpose is to convert 262 VAC on terminals 22, 24, 26, 28, 30 and 32 to 340 VDC, and to supply this voltage to the axis drive boards across the drive back plane.

When the computer is initializing, it checks the rectifier first. Then the computer checks the Axes boards. This communication is performed through the 64 pin ribbon cable. The drive rectifier uses the KM3 relay contacts and two 10 ohm resistors when starting to put a resistive load on the power going to the capacitors to protect the system from an inrush of current when the rectifier has power but to it.

Sheet 12, line 20

Sheet 9, line 04

Fig. 9-2

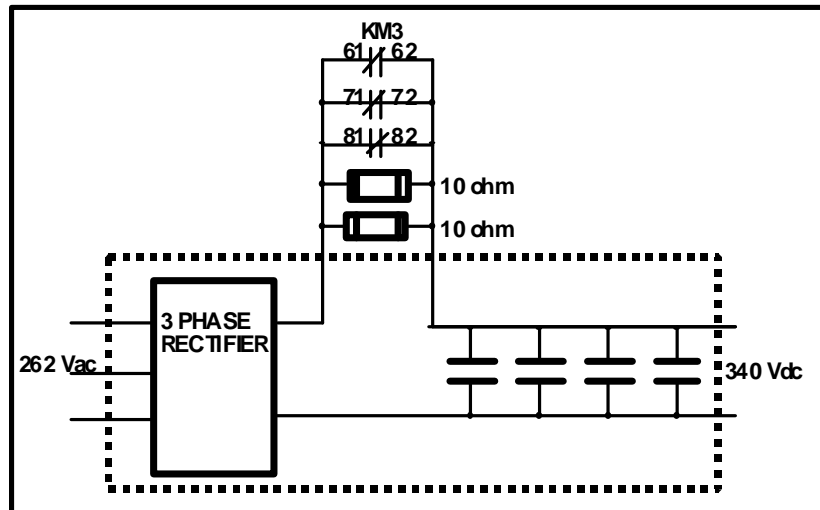

Diagram 9-2 Rectifier

Sheet 12, line 16

Fig. 9-2

The **Rectifier** also has circuitry referred to as Dynamic Braking circuits. This circuitry consists of heavy duty resistors which are used whenever the motors go into a deceleration. The resistor will absorb the current fed back from the motors causing an electronic braking action on the motor.

Rectifier (Cont)

Fig. 9-1 ➤

Fig. 9-2 ➤

If the rectifier is functioning correctly a green LED will turn ON at the front of the rectifier. (This LED will only light when the motors are turned ON.) If there is a fault on the rectifier, such as low incoming voltage, low output voltage, or rectifier over temperature, a red LED will turn ON at the front of the board, and an error will be generated on the Teach Pendant. Then the drive system will shut down. To reset the red LED, either power the cabinet OFF and then ON again, or use the INIT button on the computer back plane.



Trouble shooting of the rectifier consists of monitoring the LEDs on the front of the board. Also by checking the incoming voltage and then the output of the rectifier. Checking the output voltage can be difficult, but is possible by checking it on the rectifier board across the capacitors.



A bad rectifier can damage drive boards in some cases.



Use caution if swapping rectifier boards to find out if a board is functioning properly because other components can cause a rectifier to go bad.

Replacement of a rectifier board requires no special setups or adjustments.

9.3.2 Drive Unit

Fig. 9-2 ➡

Sheet 12, lines
1,4,7,10,14,18 ✎

There is one **Drive Board** for each axis (total of six) plugged into the drive back plane. The Robot Computer identifies each board on the back plane through the 64 pin ribbon cable. The drive boards primarily consist of at least 3 sets of two power transistors on each board. (Other circuitry on the drive boards are used to detect faults in this system) Two sets of transistors are controlled by the robot computer and the third set is calculated according to the first two. The transistors act like switches, sending 340 VDC to the motor coils. Depending on the position of the motor magnets the corresponding transistors will be turned ON to cause the motor to turn. There are at least 3 (three) wires coming out of the back of a drive board going to the motor (one wire for each phase). If there are more than three wires they just doubled or tripled up the wires.

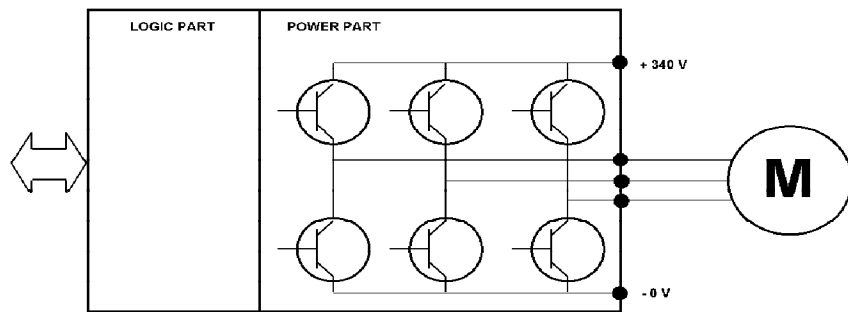

Diagram 9-3 **Drive Board**

Trouble shooting of the drive boards is performed primarily by monitoring of the red LED on the front of the board. The LED indicates a drive fault but not necessarily the drive board. (When the control is turned on the drive fault LED's are all on until the Robot Computer identifies each board from left to right.) If you get a red fault LED the first thing to do is re initialize the computer and try again. If the red LED comes on again, check for a mechanical bind by pressing the brake release push button for the axis concerned, and see if the axis moves freely. Then check the continuity of the motor and the motor wiring. The resistance of the motor coil should be approximately .5 to 2 ohms. The resistance to ground should be greater than 10 Megohms. The best way to check these resistances is by unplugging the drive board in question and checking resistance from the Back Plane through the motor. If the motor is OK then the problem is probably the drive board.

Replacement of a drive board requires no special setups or adjustments.

9.4 Motors

The **Motors** in this system are AC synchronous motors. (There are no brushes in these motors.) These motors operate through the use of magnetic fields. In simplest of terms, a motor is made up of coils (electromagnets) around the outside (known as the stator) and permanent magnets mounted on the part of the motor that rotates (known as the rotor). The diagram below shows these components.

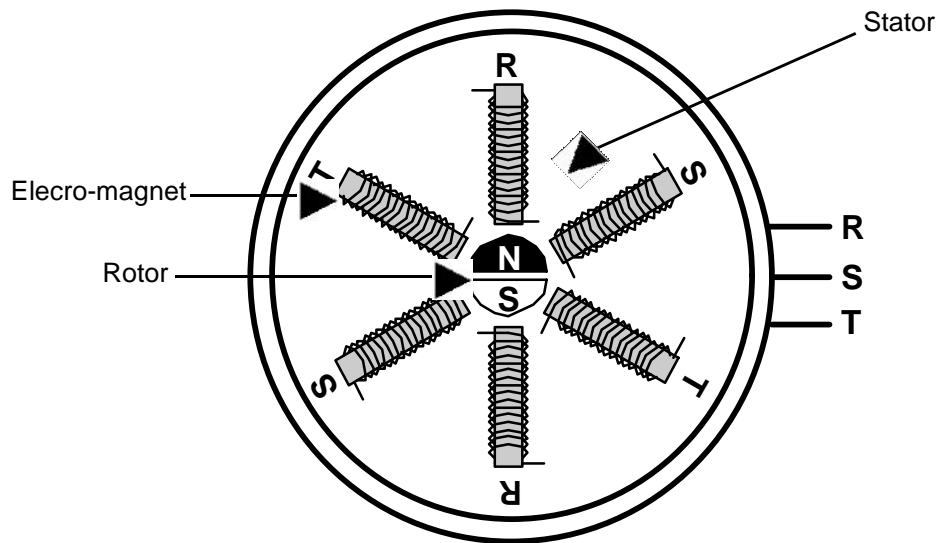

Diagram 9-4 Simplified Motor

To make the rotor rotate, 340 VDC is sent through a set of coils polarizing the electromagnet and causing the permanent magnets on the rotor to rotate by either pulling towards or pushing away from the electromagnets.

Motors (Cont)

The three motor coils are wired in a 'Y' formation. The diagram below shows the transistor and motor coil configuration.

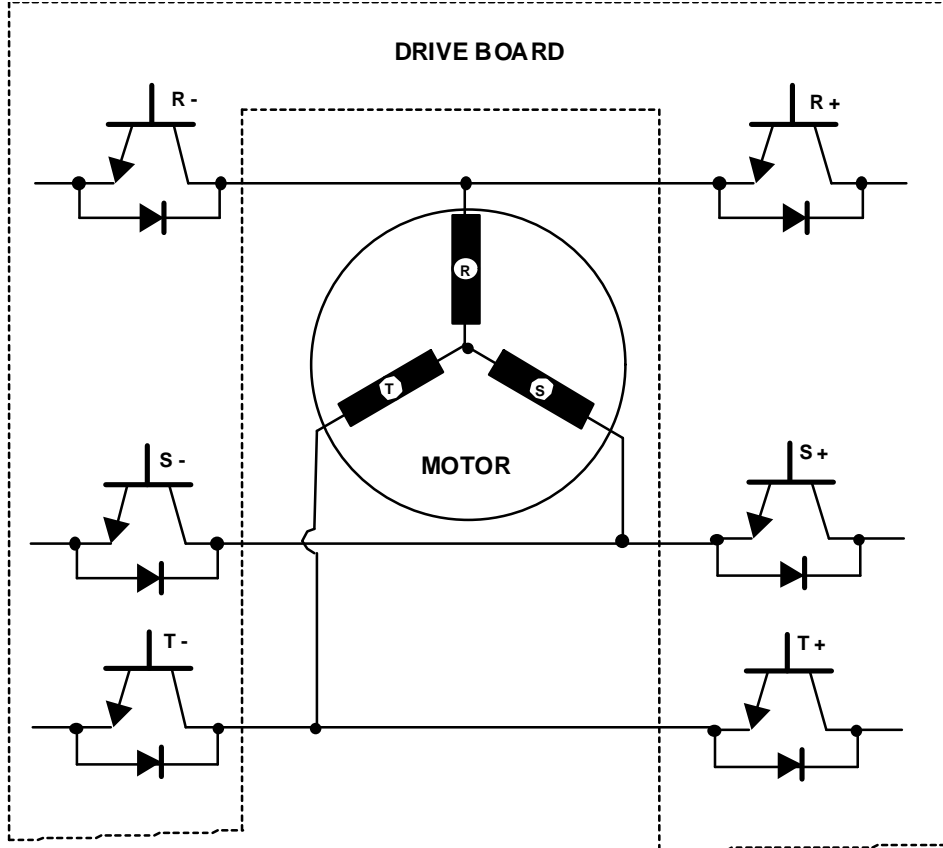

Diagram 9-5 'Y' Motor Wiring Configuration

For this motor to work it is important for the computer to know the position of the permanent magnets on the rotor. This is done by the use of the resolver mounted on the end of the motor's shaft. The alignment of the motor shaft to the resolver is known as commutation. Commutation for the IRB 6400 is set at the factory when the motor is built. All motor commutator values are 1.570800.

Sheet 105-110.....



Built into every motor is a temperature sensor device known as a PTC (positive temperature coefficient). This device increases resistance as temperature rises. The normal room temperature resistance is approximately 120 ohms.

Motors (Cont)

Sheets 105-110..... 



Troubleshooting of a motor should first consist of checking to make sure the motor and the brake releases allowing the motor to turn freely. Then troubleshoot a motor by checking the motor's coil resistance. The motor coil resistance should be approximately .5 - 2 ohms. Also check resistance to ground. A Meggar may be used to check resistance to ground. Resistance to ground should be greater than 10 Megohms. Repeated use of a Meggar may cause deterioration of motor magnets.

Replacement of a motor requires the performance of the calibration procedure and to update counter values. (See Chapter 10 - Calibration Procedures). When a motor is replaced, the shaft on the old motor must be removed and placed on the new motor.



Use caution not to pound on the motor shaft this will cause serious motor damage.

9.5 Resolver

The **Resolver** is a part of the motor. The resolver is made of coils and operates like a variable transformer. The picture below demonstrates the parts of a resolver.

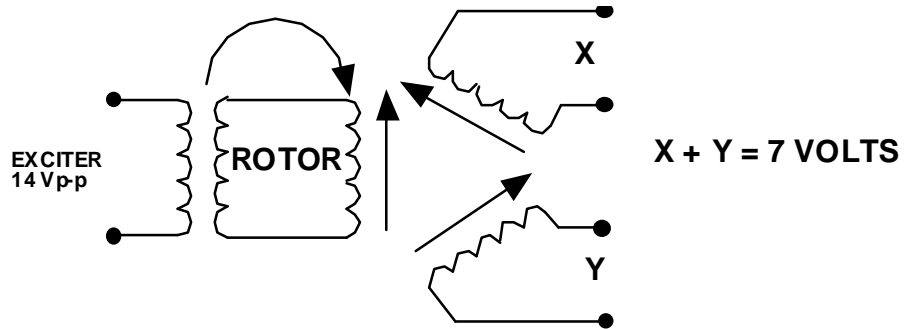

Diagram 9-6 Resolver Coil Relationships

The primary or source of the resolver is known as the **exciter**. The exciter voltage is 14 Vp-p at 4kHz. The exciter voltage is induced to a pickup coil on the rotor and then fed to the precision coils of the resolver. The voltage on the precision coils is induced across to the feedback coils known as the 'X' and 'Y' feedback coils. The voltage amplitude on the feedback coils depends upon the position of the resolver rotor. By monitoring the amplitude of the 'X' and 'Y' coils, the computer can determine the rotational position of the resolvers rotor.

Sheets 104-110.....





Troubleshooting of a resolver is done best by checking the resistance through the coils. The best place to make this check is on the SMB. The exciter coil resistance should be approximately 20 ohms. The feedback coils should be approximately 70 ohms. If resolver errors persist, use an oscilloscope to ensure proper voltage levels on the exciter and feedback coils. The total of the two feedbacks should be approximately 7 Vp-p. Use test points provided on the SMB to check voltages.

Sheet 104, line 07.....
Fig. 9-3



Replacement of a resolver is not recommended with out replacement of the motor since they are factory assembled.

9.6 Serial Measurement Board (SMB)

Sheets 104-110..... 
Fig. 9-3 

The **SMB (Serial Measurement Board)** receives the resolver feedback signals (on connectors R2.X3, R2.X4, and R2.X5) and converts the analog signals to digital signals. It then sends the digital signals to the robot computer through serial communications on R2.X2.

Sheets 13.1, line 01..... 

The communication wires going to the SMB are known as SDI (Serial Data In) and the communication wires going from the SMB are known as SDO (Serial Data Out). There is also an inverted communication signal (noted by the "-N") of each of these signals for the purpose of detecting noise. The position of all six axes resolvers are sent to the robot computer every .5 msec.

Sheets 104, line 14..... 

The SMB also keeps 'count' of the resolver of how many times the resolver has made complete revolutions. This count is sent back to the robot computer with the same serial communication as the resolver position. When the control power is shut off, a rechargeable battery (7.2 VDC) powers the SMB. This will provide the power to send a small voltage spike through the resolver every second (this is like a heart beat being sent to the resolver.) This "heart beat" is there to detect resolver revolution counts while the control power is OFF. It is not uncommon for the SMB and the robot computer to have conflicting counter values causing an error "20032 *Rev Counter Not Updated.*" If this error is encountered the revolution counters must be updated by using the procedure in Chapter 10 - Calibration Procedures.



Troubleshooting of the SMB requires the use of an oscilloscope to check the signals coming from and going to the SMB. If the signals are missing coming from the SMB the board is probably bad.



The **Batteries** on the SMB have a life expectancy of 3 years. When a battery is failing, the counters will be lost every time the disconnect is turned OFF.



Replacement of the SMB requires the updating on revolution counters. See Chapter 10 - Calibration Procedures for details.

NOTES

9.7 Component Cross Reference

Component Name	Component Location	Circuit Diagram Number	Location Figure
Computer system	Swing gate, front	--	9-1
Drive ribbon cable	Swing gate, back	Sheet 12-04	9-4
Drive system	Swing gate, upper	Sheet 12	9-2
Rectifier (DC-Link) AP9	Drive system, left	Sheet 12-20	9-2,9-4
Drive boards AP1-AP6	Drive system	Sheet 12	9-2,9-4
XS1	Cabinet, left	Sheet 12	9-4
R1.MP	Robot, back	Sheet 12, Sheets 104-110	9-3
Dynamic brake resister	Cabinet, bottom	Sheet 12-16	9-2
InRush circuits	Drive system, left	Sheet 12-09, Sheet 9-05	9-2
Motors	Robot	Sheets 105 - 110	9-3
Resolvers	Robot	Sheets 105 - 110	9-3
SMB (Serial Measurement Board) R2.X2, R2.X3, R2.X4, R2.X5	Robot, front	Sheet 13.1, Sheet 104	9-3
Init Button	Swing Gate Back		9-1
XS/XP2	Cabinet, Left	Sheet 13.1	9-4
AP80-X31	Swing Gate, bottom	Sheet 13.1	9-1
R1.SMB	Robot, back	Sheet 104, 13.1	9-3

NOTES

9.8 List of Circuit Diagrams

1.	MAINS CONNECTION	5 of 43
2.	POWER UNIT	9 of 43
3.	6400 DRIVE SYSTEM	12 of 43
4.	CONTROL CABLE	13.1 of 43
5.	BRAKE UNIT SERIAL MEAS. BOARD	104 of 12
6.	AXIS 1	105 of 12
7.	AXIS 2	106 of 12
8.	AXIS 3	107 of 12
9.	AXIS 4	108 of 12
10.	AXIS 5	109 of 12
11.	AXIS 6	110 of 12

NOTES

Figure 9-1 Back Plane AP80

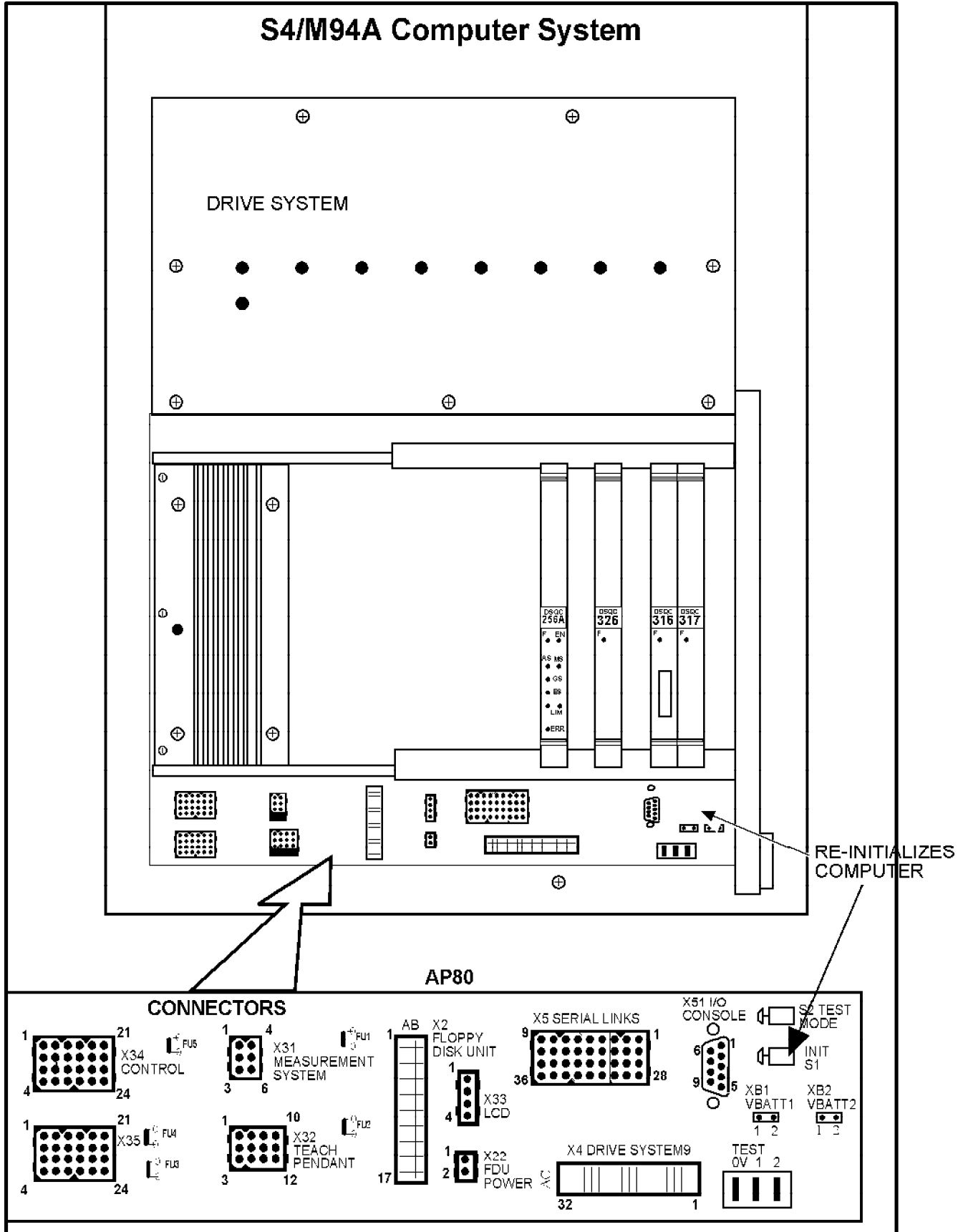

RE-INITIALIZES COMPUTER

NOTES

Figure 9-2 Drive System Boards

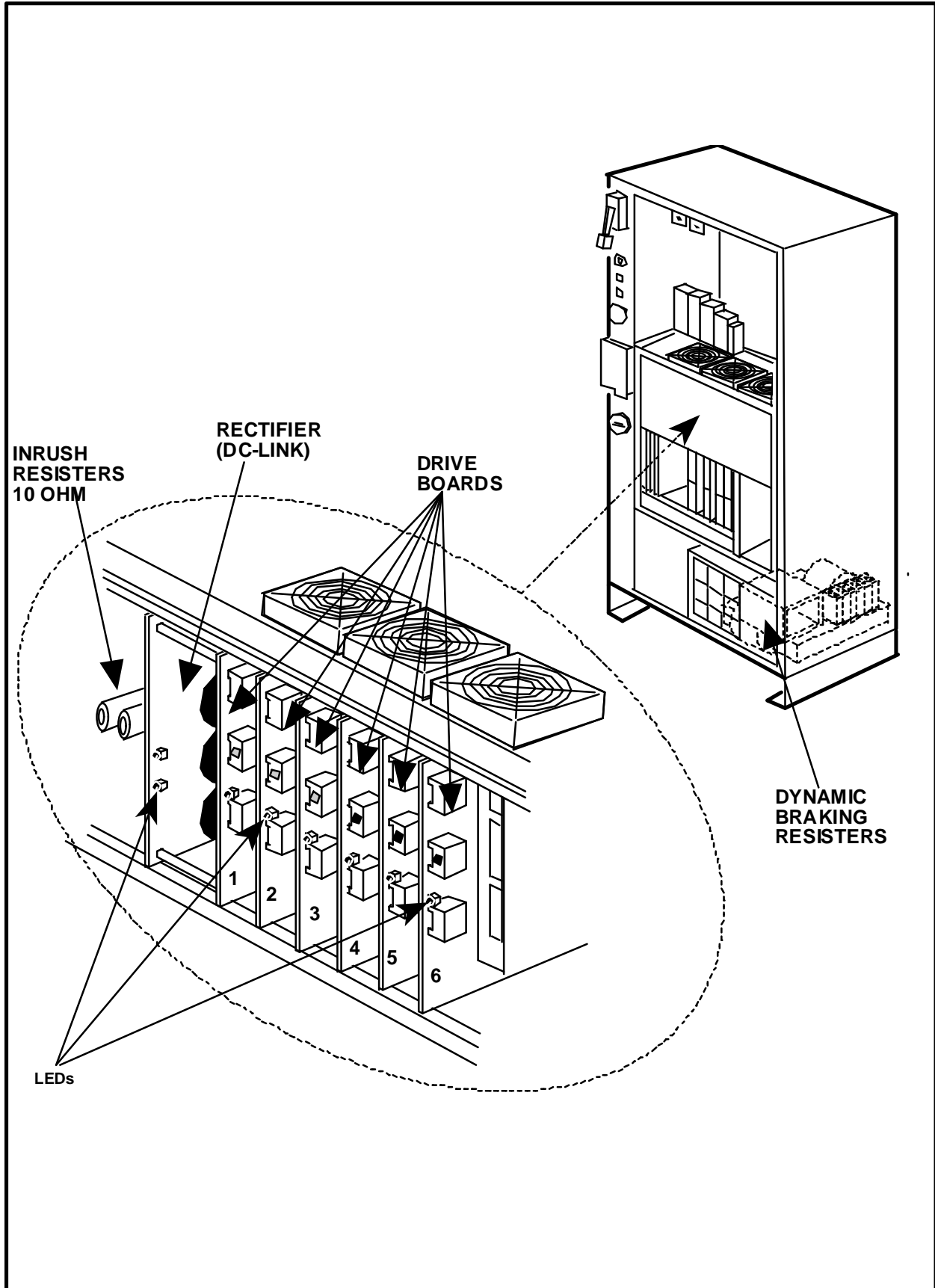

NOTES

Figure 9-3 Robot Axis Motors

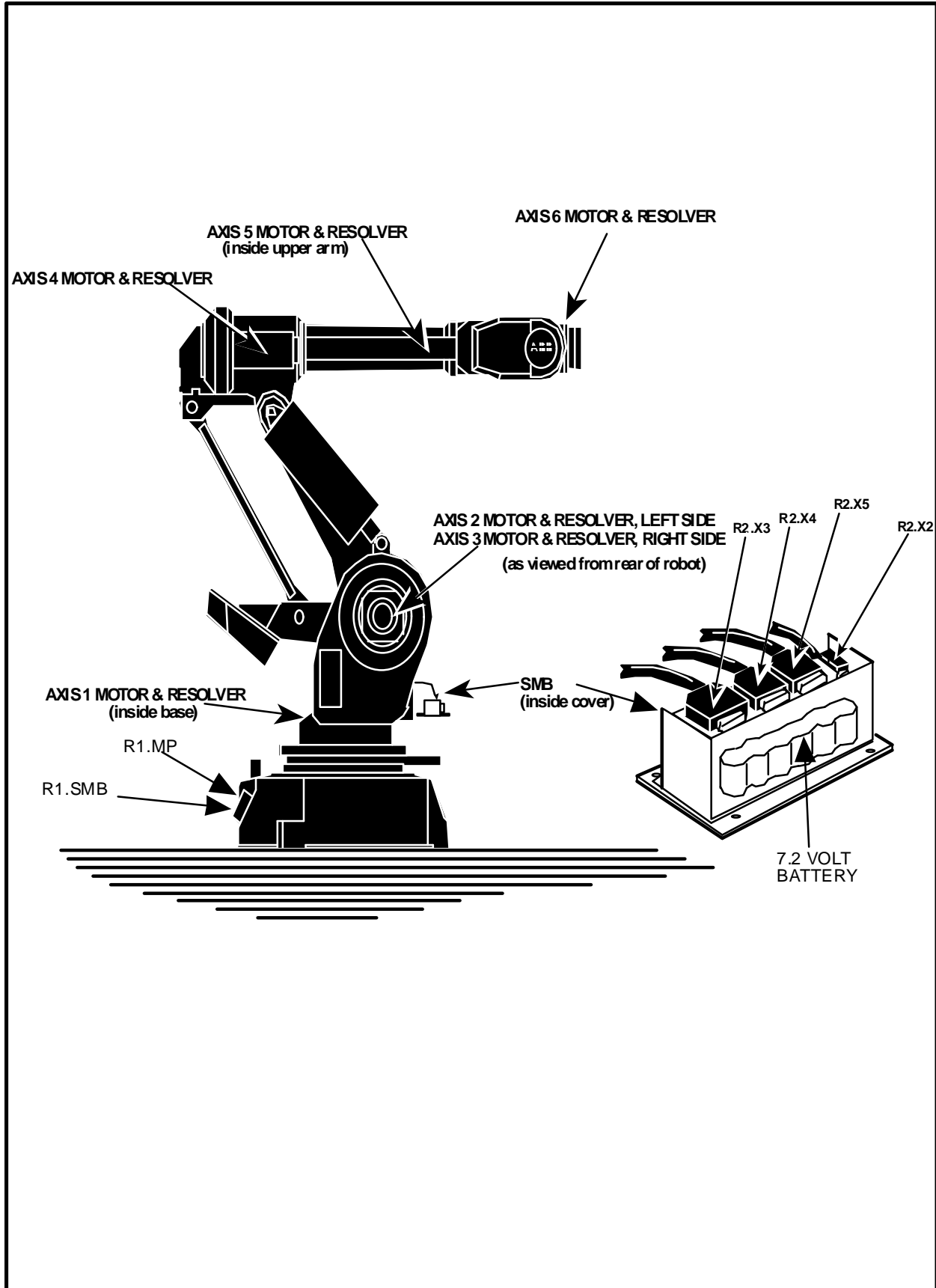

NOTES

Figure 9-4 Drive Connectors

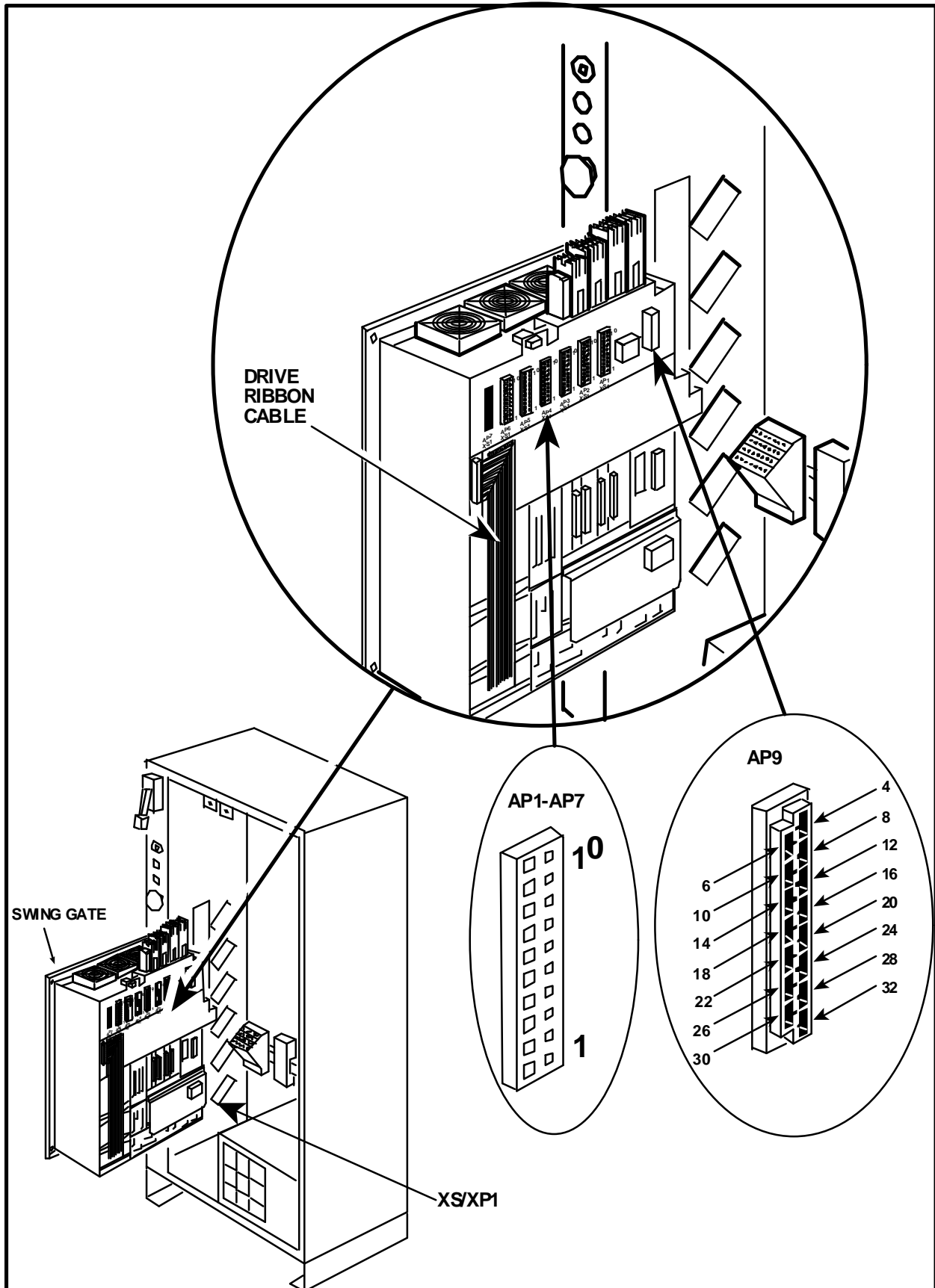

NOTES

CHAPTER 10

CALIBRATIONS



Calibration Procedures

Table of Contents

10.	Calibration Procedures.....	10-3
10.1	Overview	10-3
10.2	"Rough" Resolver Calibration Procedure	10-4
10.3	Manually Entering Calibration Values	10-10
10.4	Precision Resolver Calibration Procedure	10-14
	10.4.1 Calibrating Axis 1	10-15
	10.4.2 Calibrating Axis 2-6	10-16
10.5	Counter Updating Procedure	10-23

NOTES

IO. Calibration Procedures

10.1 Overview



The IRB 6400 measurement system consists of one resolver for each axis connected to a SMB (serial measurement board). The resolvers provide an analog voltage corresponding to the resolvers rotated position. Then the SMB converts this analog voltage to a digital signal and sends the information serially to the robot computer board. The serial measurement board also keeps track of the current resolver revolution count. To keep track of these revolution counts even when power is turned off the SMB has a rechargeable battery attached to it. When a new machine is shipped from the factory this battery may not be charged. The control must be connected to the robot and with the main disconnect turned on it takes 18 hours to fully charge this battery and it should maintain a charge for approximately 1000 hours. If this battery loses its charge an error “20032 Rev counter not updated” will be given after a power outage.

When the robots are assembled they are accurately calibrated using digital levels and calibration fixturing. The calibration values are recorded on a paper stuck to the robots casting next to the axis 1 motor and they are also saved on the “Boot Disk 4” which is shipped with each robot.

In this chapter four calibration procedures will be discussed. They are:

- Rough resolver calibration procedure.
- Manually entering calibration values.
- Precision resolver calibration procedure.
- Counter updating procedures.

Each procedures purpose and when it should be used is explained in each procedure.

10.2 "Rough" Resolver Calibration Procedure



The only time that the resolvers should be calibrated using this method is when the resolver has been mechanically disassembled from the mechanical unit. (Such as if a motor is removed.)

The term "rough" resolver calibration is used to indicate that this is not the most accurate way to calibrate the resolvers. However it is the easiest and fastest way to calibrate the resolvers in most cases. After performing this procedure program touch up may be required.



NOTE: If your application can not tolerate this rough calibration then you may want to use the precision resolver calibration procedure in this chapter.

1. Move the axis (by using the joystick) to be calibrated to the calibration position. The more accurate this is done the better the calibration will work. The calibration position is shown in the figure below.

There are calibration plates mounted on each axis to indicate when the robot is at its calibration position.

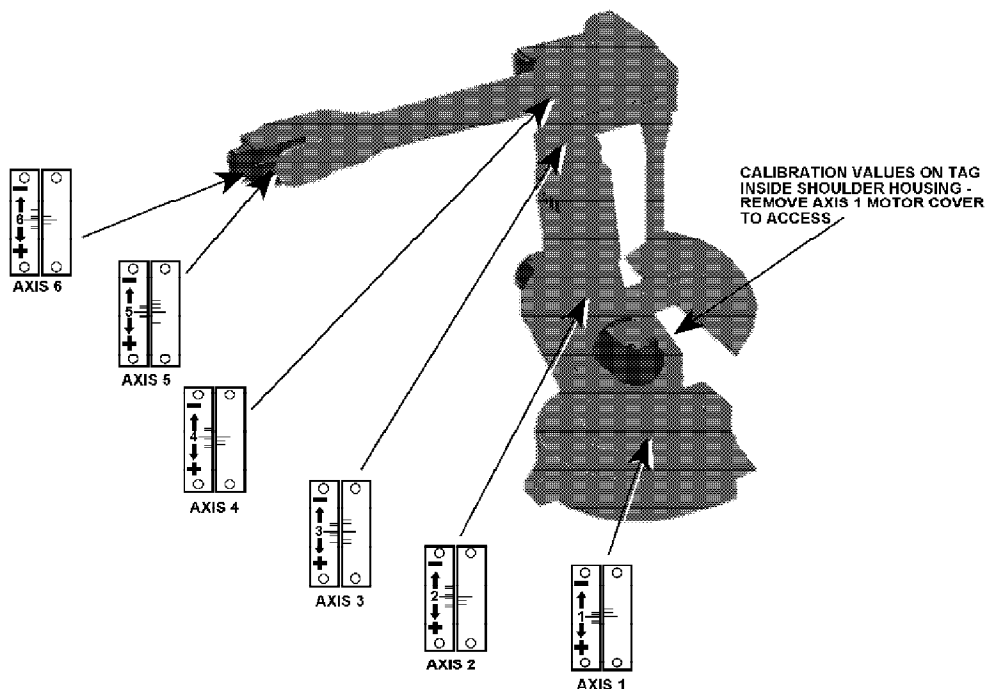

NOTE: If Axis 3 is to be moved to its calibration position you must move Axis 2 to its calibration position first.

Rough Resolver Calibration Procedure (Cont)

2. After the axis has been moved to its calibration position the resolver value must be recorded. Release the enable device before continuing with this procedure. This is done on the teach pendant.

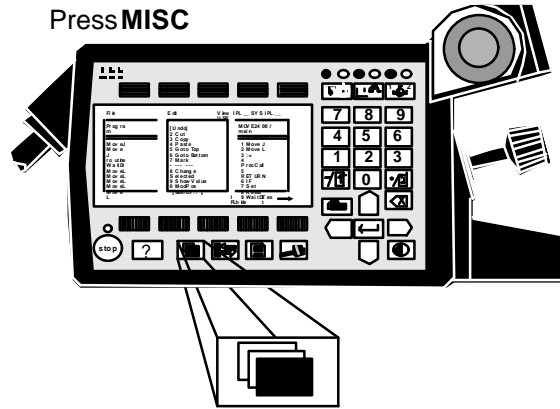

Select:

SERVICE
VIEW
CALIBRATION.

The figure below should appear.

File	Edit	View	Calib
Service Calibration			
Unit	Status	1 (1)	
IRB	Not Calibrated		

The calibration status will appear on the screen.

Rough Resolver Calibration Procedure (Cont)

The calibration status can be any of the following:

Synchronized - Indicates that there are calibration values for each axis and that the counters are updated. This does **NOT** necessarily mean that they are correct.

Not updated rev. counter - Indicates that one or more axis revolution counter is not updated.

Not calibrated - Indicates that one or more axis do not have calibration values stored.

3. Press:

CALIB
CALIBRATE

The window below will appear.

Calibrate		
IRB		
To calibrate, include axes and press OK.		
Axis		Status
X	1	Not Calibrated
X	2	Not Calibrated
	3	Calibrated
	4	Calibrated
	5	Calibrated
	6	Calibrated
Incl	All	Cancel OK

4. The "X" indicates chosen axes. Press the **ALL** function button to select all axis to be calibrated or move the cursor to the desired axis or axes and press **INCL** to include the axes to be calibrated.

Rough Resolver Calibration Procedure (Cont)

5. Press **OK**. The window below will appear.

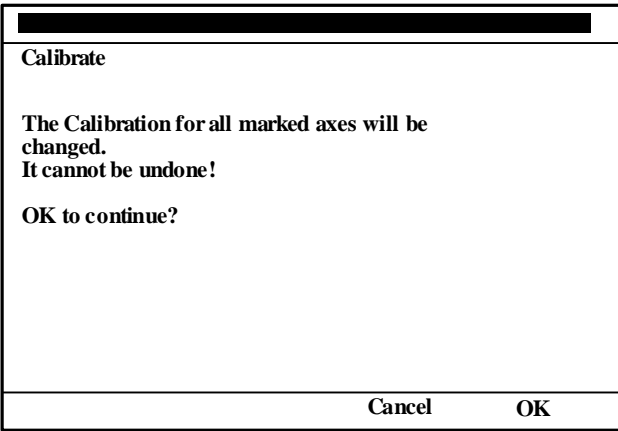

6. After receiving the warning if you wish to continue press **OK** again. The following screen should appear.

File	Edit	View	Calib
Service Calibration			
Unit	Status		1 (1)
IRB	Synchronized		

Rough Resolver Calibration Procedure (Cont)

- Now the calibration values need to be recorded on the paper in the Axis 1 casting.

To see the new resolver values press:

MISC
 SYSTEM PARAMETERS
 MANIPULATOR
 TYPES
 MOTOR

You should see the screen below.

File	Edit	Topics	Types
System Parameters		Manipulator	
Motor			
Name		Type	
		1 (6)	
irb_1		3HAB 4039-1	
irb_2		3HAB 4040-1	
irb_3		3HAB 4040-1	
irb_4		3HAB 4041-1	
irb_5		3HAB 4041-1	
irb_6		3HAB 4042-1	

- Then select the axis desired. See the screen below.

System Parameters		Manipulator
Motor		
Motor		Info
		1 (6)
Name	irb_1 ...	
Use Motor Type	3HAB 4039-1...	
Commutator Offset	1.570800...	
Calibration Offset	4.002827...	
Com Offset Valid	YES	
Cal Offset Valid	YES	
		Cancel Enter

Rough Resolver Calibration Procedure (Cont)

9. The information shown is:

NAME	The name given to the axis (example: motor_1).
CAL OFFSET	The value of the resolver when it is at the calibration position. This value is in radians.
COM OFFSET	The commutation value for the motor. On the IRB 6400 this value is always 1.570800. This value is in radians.
CAL OFFSET VALID	Confirmation that the calibration values are valid. This should be "YES".
COM OFFSET VALID	Confirmation that the commutation values are valid. This should be "YES".

10. The value to put on the paper is the CAL OFFSET value.

11. The CAL OFFSET value must also be stored on the floppy disk. This is done while you are still looking at the resolver values by pressing:

```
FILE  
SAVE AS
```

The resolver values will automatically use the file name of `MOC.CFG`. You may use a different filename if desired but it is not recommended. Save these values to your Boot Disk 4 and all back up copies.

10.3 Manually Entering Calibration Values

Manually entering calibration values should be done when:

- a) Robot is installed.
- b) After system software is loaded.
- c) After replacement of the Main computer, Robot Computer, or Memory Boards.

There are two ways to enter the calibration values into the control they are:

- 1. By disk
- 2. Manually entering calibration values.

To enter the calibration values by disk:

- 1. Press:

```
MISC
SYSTEM PARAMETERS
TOPIC
MANIPULATOR
```

The following screen should be seen.

File	Edit	Topics	Types
System Parameters		Manipulator	
Motor			
Name		Type	
			1 (6)
irb_1		3HAB 4039-1	
irb_2		3HAB 4040-1	
irb_3		3HAB 4040-1	
irb_4		3HAB 4041-1	
irb_5		3HAB 4041-1	
irb_6		3HAB 4042-1	

Manually Entering Calibration Values (Cont)

2. Insert the disk that has the resolver values saved on it. This should be Boot Disk 4 or another disk. Press:

FILE
LOAD SAVED PARAMETERS

Select the file with the resolver values in it. This should be a file named "MOC.CFG". Press **OK**.

Save Parameter As!	
Name: Moc...	
Massmemory Unit = flp1:	
\syspar _____ 1 (6)	
..	Go up one level
EIO	Parameters
MMC	Parameters
MOC	Parameters
PROC	Parameters
Cancel OK	

Manually Entering Calibration Values (Cont)

Another way to enter calibration values manually:

1. Get the correct resolver values from the paper next to the Axis 1 motor or wherever you have them recorded.
2. Press:

MISC
SYSTEM PARAMETERS
TOPICS
MANIPULATOR
TYPES
MOTOR

You will see the screen below.

File	Edit	Topics	Types
System Parameters		Manipulator	
Motor			
Name	Type		1 (6)
irb_1	3HAB 4039-1		
irb_2	3HAB 4040-1		
irb_3	3HAB 4040-1		
irb_4	3HAB 4041-1		
irb_5	3HAB 4041-1		
irb_6	3HAB 4042-1		

Manually Entering Calibration Values (Cont)

- Then select the axis desired and press **ENTER**. See the screen below.

System Parameters		Manipulator
Motor		
Motor	Info	1 (6)
Name	irb_1...	
Use Motor Type	3HAB 4039-1...	
Commutator Offset	1.570800...	
Calibration Offset	4.002827...	
Com Offset Valid	YES	
Cal Offset Valid	YES	
		Cancel OK

- The information shown is:

NAME	The name given to the axis (example: motor_1).
CAL OFFSET	The value of the resolver when it is at the calibration position. This value is in radians.
COM OFFSET	The commutation value for the motor. On the IRB 6400 this value is always 1.570800. This value is in radians.
CAL OFFSET VALID	Confirmation that the calibration values are valid. This should be "YES".
COM OFFSET VALID	Confirmation that the commutation values are valid. This should be "YES".

- Move the cursor to **CAL OFFSET**. Press **ENTER** and type the correct calibration values.
- When completed press **OK**.

10.4 Precision Resolver Calibration Procedure

The precision resolver calibration procedure is used when proper alignment after a motor replacement is critical. An example of a program that would need the precision resolver calibration procedure is a program that run many different part routines. To perform this procedure it is required to use the calibration equipment (3HAA 0001-MZ). Also needed to accomplish this procedure will be digital leveling equipment. This equipment does not come with the robot. This equipment can be purchased through ABB.



The only time that the resolvers should be calibrated using this method is when the resolver has been mechanically disassembled from the mechanical unit. (Such as if a motor is removed.)

Adjust axes in increasing sequence, i.e., 1, 2, 3, 4, 5, then 6.

1. Position the robot approximately in calibration position 0 as shown below.

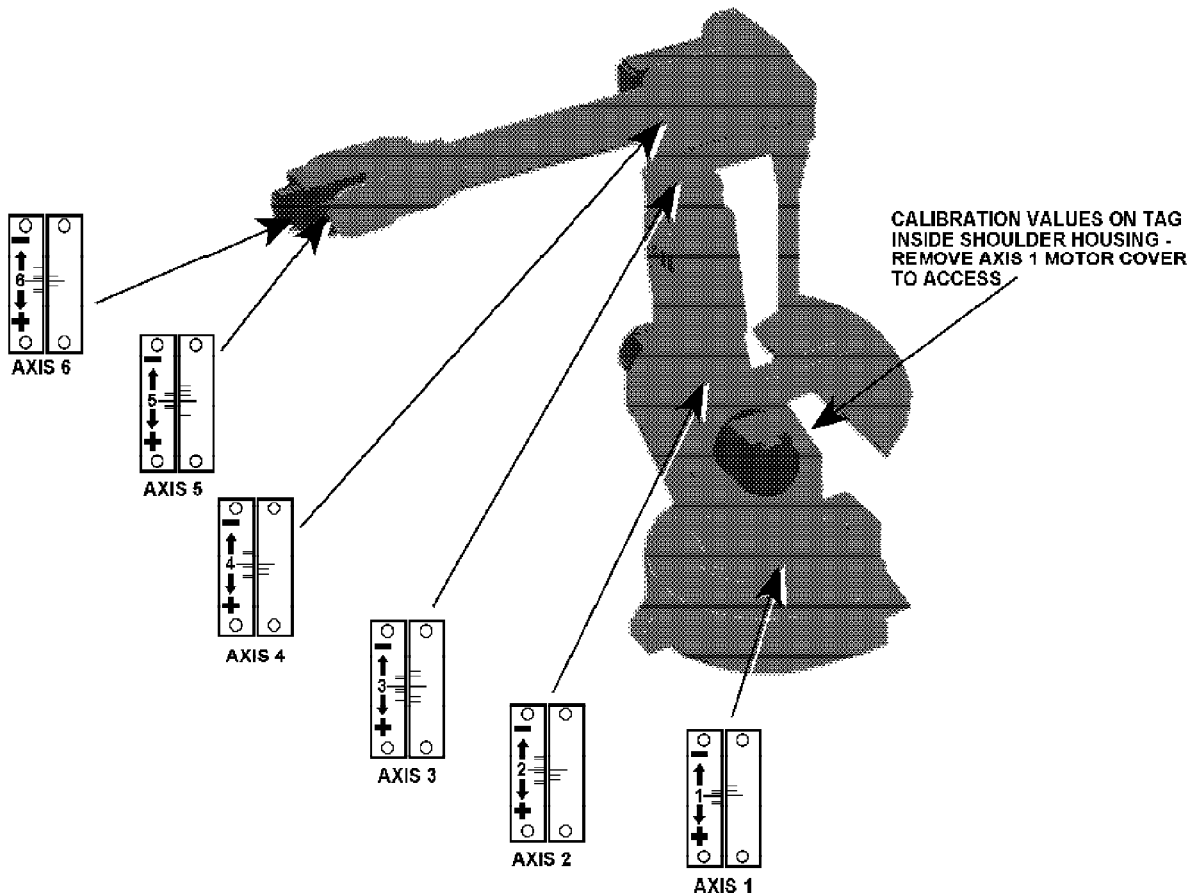

Precision Resolver Calibration Procedure (Cont)

2. Select the **MOTORS OFF** mode.

10.4.1 Calibrating Axis 1

3. Remove cover plate on the reference surface on gearbox 1.
4. Attach the synchronization fixture (ABB# 6896 0011-YM) to the flat surface and insert the corresponding measuring rod (6896 0011-YN) in one of the three holes in the base.
5. Use the Manual Brake Release Switch for Axis 1 and manually push the robot until the measuring rod is positioned within the flat surface on the calibration fixture's elbow.



WARNING! BE ESPECIALLY CAREFUL OPERATING THE ROBOT WHILE IN THE ROBOT WORKING AREA OR PERSONAL INJURY MAY OCCUR!

6. Align the pin and tool with a sliding caliper.

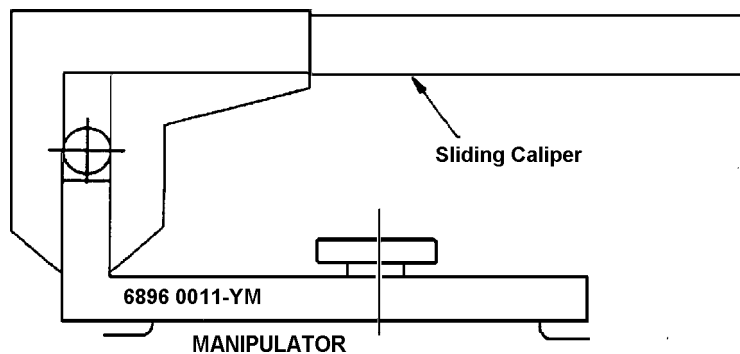

Figure 1 - Aligning the Pin & Tool with a Sliding Caliper for Axis 1

Precision Resolver Calibration Procedure (Cont)

Calibrate the sensors against each other using a reference plane surface in the same direction. The sensors must be calibrated every time they are used for a new direction.

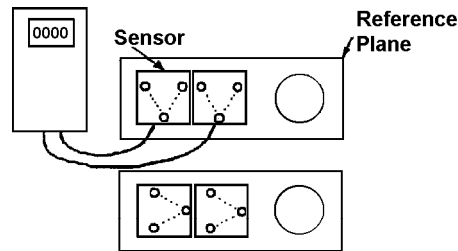

Figure 2 - Calibrating the Sensors

10.4.2 Calibrating Axis 2-6

7. Release the enabling device.
8. Mount sensor fixture (6896 0011-GM) on the base reference plane.
9. Mount elbow fixture (6896 0011-LP) on the lower arm calibration plane.
10. Mount sensor fixture (6808 0011-GM) on the wrist calibration plane turned upwards.
11. Mount intermediate plate (6896 134-GZ) on the turn disc. Mount elbow fixture (6808 0011-GU) on the intermediate plate. Note that the elbow fixture position is adjusted with a guide pin.
12. Mount inclination instrument (6807 081-D). One sensor is to be mounted on the reference plane and the other on the elbow fixture for Axis 2. Both sensors are to be positioned in the same direction. See also Figure 3.

NOTE: The sensor unit must always be mounted on top of the fixture.

Precision Resolver Calibration Procedure (Cont)

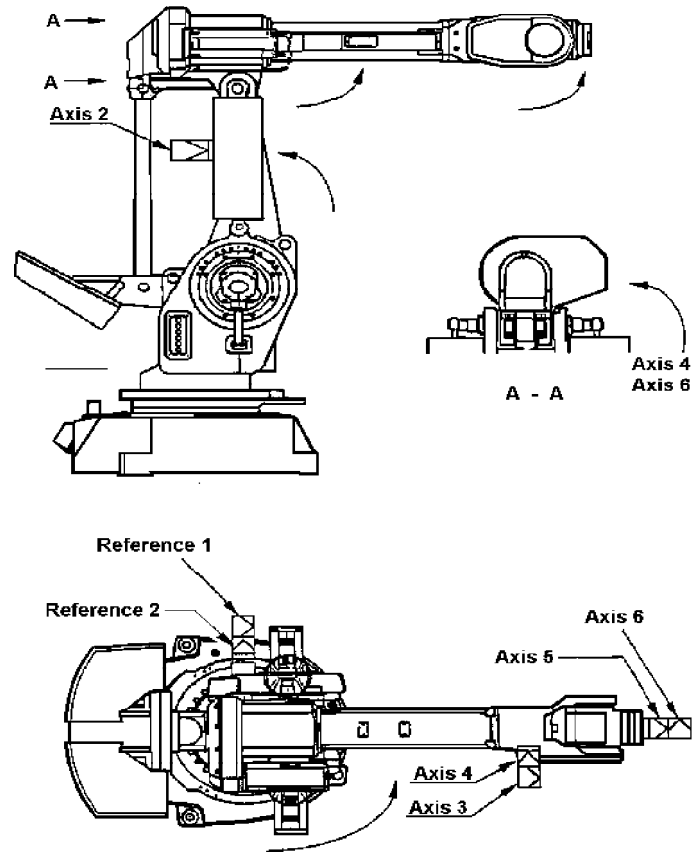

Figure 3 - Movement Directions for Calibration, Reference Surface

13. Press the enabling device and operate the joystick manually in the directions in Figure 3 until the digital leveling gauge indicates zero. The gauge should read 0 ± 12 increments (0.3 mm/m).

The reason the calibration position is always adjusted in the directions shown in Figure 3 is that friction and gravity forces work together against the direction of movement. This simplifies adjustment.

14. Turn the reference sensor and move the other sensor. Continue the calibration procedure for the other axes.
15. When all axes have been adjusted, the resolver values are stored by executing commands listed (following steps 16 through 25) on the teach pendant.

Precision Resolver Calibration Procedure (Cont)

16. After the axis has been moved to its calibration position the resolver value must be recorded. This is done on the teach pendant. Press:

MISC

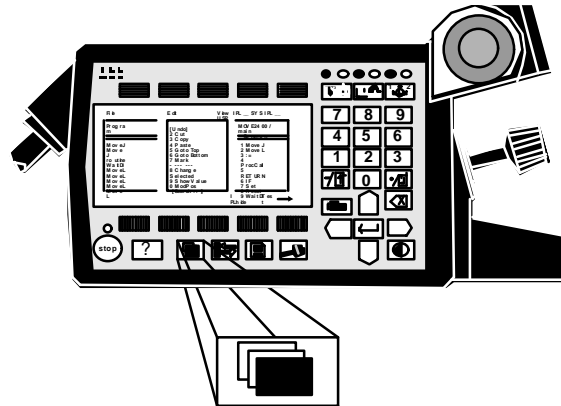

Figure 4 - Misc. Window Key to Select Service Window

Select:

SERVICE
VIEW
CALIBRATION.

The figure below should appear.

File	Edit	View	Calib
Service Calibration			
Unit	Status		1 (1)
IRB	Not Calibrated		

Precision Resolver Calibration Procedure (Cont)

The type of calibration status will appear on the screen. The status can be any of the following:

Synchronized - Indicates that there are calibration values for each axis and that the counters are updated. This does **NOT** necessarily mean that they are correct.

Not updated rev. Counter - Indicates that one or more axis revolution counter is not updated.

Not calibrated - Indicates that one or more axis do not have calibration values stored.

17. Press:

CALIB
CALIBRATE

The window below will appear.

Calibrate			
IRB			
To calibrate, include axes and press OK.			
	Axis	Status	
	1	Not Calibrated	3 (6) =
X	2	Not Calibrated	
X	3	Calibrated	
	4	Calibrated	
	5	Calibrated	
	6	Calibrated	
Incl	All	Cancel	OK

18. The "X" indicates chosen axes. Press the ALL function button to select all axis to be calibrated or move the cursor to the desired axis or axes and press INCL to include the axes to be calibrated.

Precision Resolver Calibration Procedure (Cont)

19. Press **OK**. The window below will appear.

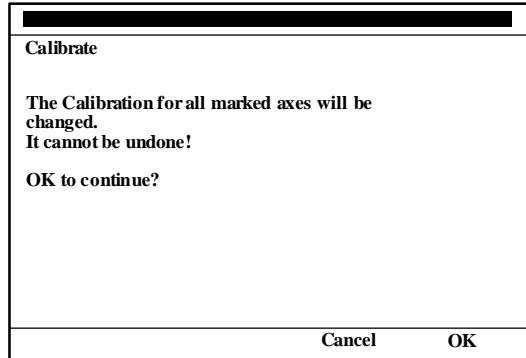

20. After receiving the warning if you wish to continue press **OK** again. The following screen will appear.

File	Edit	View	Calib
Service Calibration			
Unit	Status	1 (1)	
IRB	Synchronized		

Precision Resolver Calibration Procedure (Cont)

21. Now the calibration values need to be recorded on the paper in the Axis 1 casting. To see the new resolver values press:

MISC
 SYSTEM PARAMETERS
 MANIPULATOR
 TYPES
 MOTOR

You will see the screen below.

File	Edit	Topics	Types
System Parameters		Manipulator	
Motor			
Name	Type	1 (6)	
irb_1	3HAB 4039-1		
irb_2	3HAB 4040-1		
irb_3	3HAB 4040-1		
irb_4	3HAB 4041-1		
irb_5	3HAB 4041-1		
irb_6	3HAB 4042-1		

22. Then select the axis desired. See the screen below.

System Parameters		Manipulator
Motor		
Motor	Info	1 (6)
Name	irb_1 ..	
Use Motor Type	3HAB 4039-1..	
Commutator Offset	1.570800...	
Calibration Offset	4.002827...	
Com Offset Valid	YES	
Cal Offset Valid	YES	
Cancel		Enter

Precision Resolver Calibration Procedure (Cont)

23. The information shown is:

NAME	The name given to the axis (example: motor_1).
CAL OFFSET	The value of the resolver when it is at the calibration position. This value is in radians.
COM OFFSET	The commutation value for the motor. On the IRB 6400 this value is always 1.570800. This value is in radians.
CAL OFFSET VALID	Confirmation that the calibration values are valid. This should be "YES".
COM OFFSET VALID	Confirmation that the commutation values are valid. This should be "YES".

24. The value to put on the paper is the CAL OFFSET value.

25. The CAL OFFSET value must also be stored on floppy disk. This is done while you are still looking at the resolver values by pressing:

FILE
SAVE AS

The resolver values will automatically use the file name of MOC.CFG. You may use a different filename if desired but it is not recommended. Save these values to your Boot Disk 4 and all back up copies.

10.5 Counter Updating Procedure

The Serial Measurement Board (SMB) keeps track of the current resolver revolution count. To keep track of these revolution counts even when power is turned off, the SMB has a rechargeable battery attached to it. When a new machine is shipped from the factory this battery may not be charged. The control must be connected to the robot, and with the main disconnect turned ON, it takes 18 hours to fully charge this battery. It should maintain a charge for approximately 1000 hours. If this battery loses its charge, an error "20032 Rev counter not updated" will be given after a power outage.

Other reasons for having to update counters are:

- When a resolver error has occurred
- When the signal between the resolver and SMB has been interrupted.
- When one of the manipulator axis has been moved without the controller being connected.



You should NOT have to update the counter upon powering off and back on again. If you do there is a problem in the system.

1. Move the robot to the calibration position. Axis may be moved and updated individually, except for axis three. Axis three's position depends on axis two's position. Always have axis two in position before moving axis three into position.



IMPORTANT Axis 6 has no hard stops which means that when a robot does not have its revolution counters Axis 6 is allowed to rotate endlessly. However the revolution counter will only be correct at one position and being multiple axis revolutions off won't work.

Counter Updating Procedure (Cont)

The figure below shows all six axis in the calibration position. NOTE if counter values are lost the robot will not move in linear motion.

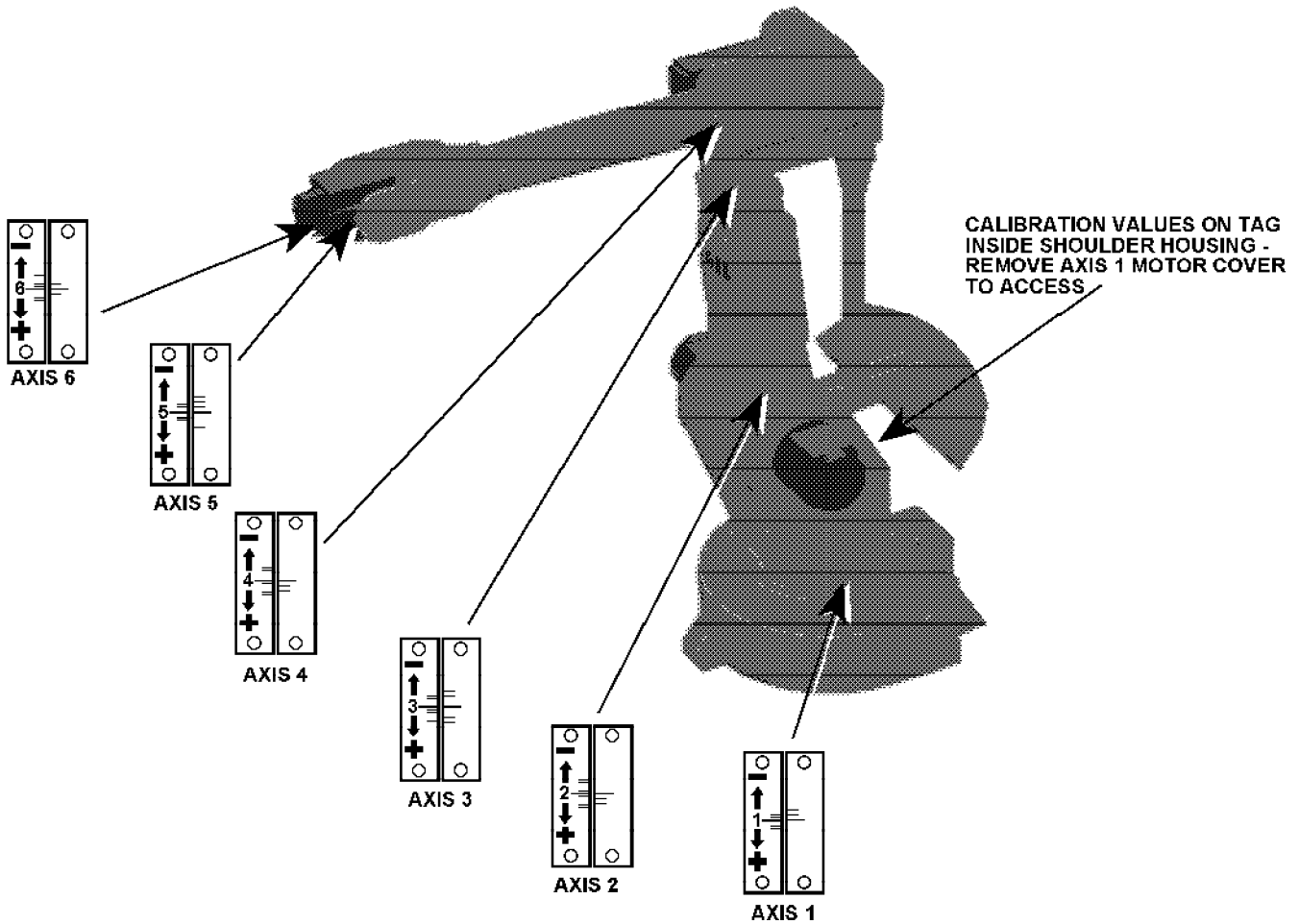

Counter Updating Procedure (Cont)

- When the robot has been moved into the calibration position press:

MISC
SERVICE
VIEW
CALIBRATION

The following screen should be displayed.

File	Edit	View	Calib
Service Calibration			
Unit		Status	1 (1)
IRB		Not Rev. updated	

- Press:

CALIB
REV. COUNTER UPDATE

The following screen will be displayed.

Calibrate			
IRB			
To calibrate, include axes and press OK.			
	Axis	Status	3 (6)
X	1	Not Calibrated	
X	2	Not Calibrated	
	3	Calibrated	
	4	Calibrated	
	5	Calibrated	
	6	Calibrated	
Incl	All	Cancel	OK

Counter Updating Procedure (Cont)

4. Move the cursor to the desired axis to be updated and press **INCL** or press **ALL** to include all axis. The selected axis will be marked with an "X".
5. Press **OK**. A warning message will be displayed. If everything is correct then press **OK** again.
6. It is very important after completing this procedure to load and run the calibration program on the Boot Disk 4. Explanations on how to do this is in the software loading chapter. If the calibration marks do not line up after running the calibration program repeat procedure for axis that are off. If mispositioning persists the resolver system must be repaired. If a problem occurs for Axis 6 the cause may be that Axis 6 has been rotated to the wrong revolution. If the correct revolution can not be found then the axis must be recalibrated using one of the previous procedures.

NOTES

NOTES

CHAPTER II

INPUTS & OUTPUTS

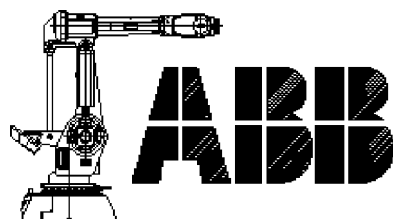

Inputs & Outputs

Table of Contents

11.	Inputs & Outputs.....	11-3
11.1	Overview	11-3
11.2	I/O Boards	11-4
11.2.1	Digital I/O Board DSQC 223.....	11-4
11.2.2	Analog I/O Board DSQC 209.....	11-5
11.2.3	Combined I/O Board DSQC 315.....	11-6
11.2.4	Remote I/O Board DSQC 239.....	11-7
11.3	Board Connections	11-8
11.3.1	External I/O Connections (Conn. option 31X)....	11-9
11.3.2	Internal I/O Connections (Conn. option 34X)....	11-13
11.3.3	Relay Unit (Conn. option 37X).....	11-16
11.3.4	120 VAC Modules (Conn. option 35X).....	11-18
11.3.5	Manually Operated I/O.....	11-19
11.4	Component Cross Reference	11-21
11.5	List of Circuit Diagrams	11-23
11.6	Component Location Figures	11-40
	Figure 11-1 XS3/XT3	11-40
	Figure 11-2 Screw Terminals	11-41
	Figure 11-3 120 VAC I/O Connector.....	11-42

NOTES

II. Inputs & Outputs

11.1 Overview

The I/O system consists of:

- Robot computer
- System backplane
- Up to six I/O boards

The robot computer board has a processor, (I/O computer), dedicated to handling all I/O communications. Each I/O slot can accommodate a variety of I/O boards.

The types of I/O boards available are:

DSQC 223 Digital I/O (24VDC),
 DSQC 209 Analog I/O (0-10V),
 DSQC 315 Combined I/O
 DSQC 239 (RIO option available for Allen Bradley programmable controllers.)

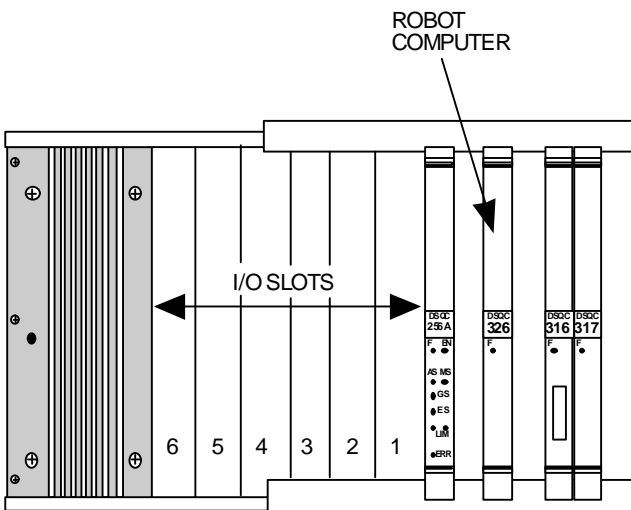

Along with the different types of I/O boards there are also several different I/O board connection options.

The connection options are:

- External connections,
- Internal screw connections (24 VDC),
- Internal screw connections (120 VAC),
- Internal relay unit (220 VAC).

The type of I/O board and the use of the I/O is defined in system parameters.

In this chapter each type of I/O board will be described with troubleshooting diagnostics and procedures. The different I/O connection options will also be explained with examples of wiring different I/O devices. The manual operation of I/O will also be discussed.

11.2 I/O Boards

11.2.1 Digital I/O Board DSQC 223

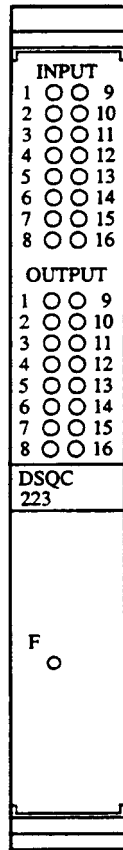

<u>Designation</u>	<u>Color</u>	<u>Description</u>
INPUT	Yellow	Turns ON when it receives a high signal from an input. The LED shines more brightly the more voltage is input. This means that even if the input voltage is just under the voltage level "1", the LED will glow dimly.
OUTPUT	Yellow	Turns ON when a high signal is sent from an output. The LED shines more brightly the more voltage is output.
F	Red	Turns off when the board approves the initialization.

The digital I/O Board may be put in any I/O slot. The I/O slots are populated from right to left. The system can accommodate up to 6 digital I/O boards.

The digital input and output board, DSQC 223, has 16 opto-isolated inputs and 16 opto-isolated outputs. Each input and output has its own yellow LED which indicates whether or not the input/output is activated. The inputs and outputs normally receive their 24VDC supply from a customer connection, but this can also be supplied internally (XS3/XT3 terminals A15,B15,A16,B16,C16). If none of the I/O channels work, check first that the boards are initialized (the red F-LED should be OFF on all I/O boards). Note that if, for some reason, the system's parameters change, the red LED may be ON. Otherwise, the red LED may indicate that the I/O boards are faulty.

Check also that the boards have a 24VDC supply (internal or external). Common sources of errors are cable faults, sensor faults, etc.

You can use the I/O window on the teach pendant to check whether the current I/O board is functioning properly. Refer to the Manual Operation (page 11-19) in this chapter.

If **replaced**, there are no adjustments or procedures required.

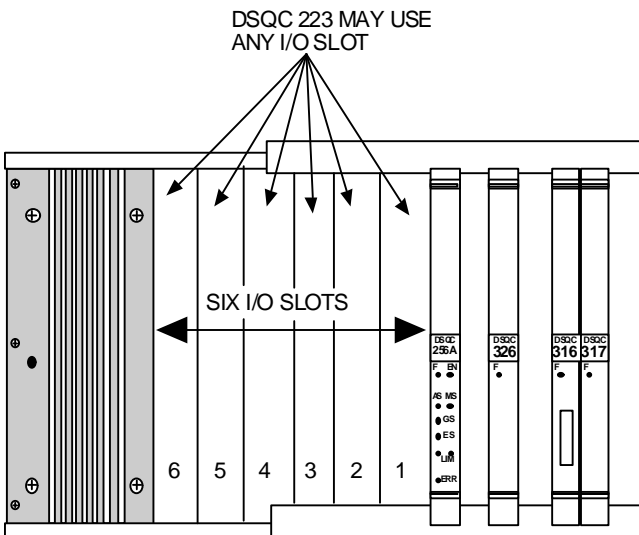

11.2.2 Analog I/O Board DSQC 209

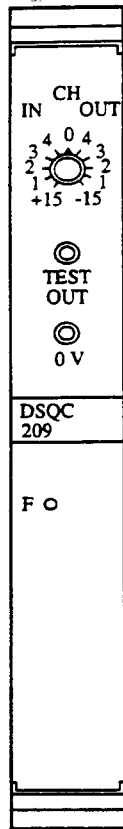

<u>Designation</u>	<u>Label</u>	<u>Description</u>
Test switch	+15:	+ supply
	IN 1-4:	input signal
	0:	0V
	OUT 1-4:	output signal
	- 15:	- supply
Test out	Measuring terminal	The analog value of the signal indicated by the test switch.
0V	Measuring terminal	0V
F	Red	Turns off when the board approves the initialization.

The Analog I/O board may only be used in the first I/O slot. This also means that only one Analog I/O board can be used per system.

The Analog I/O board, DSQC 209, converts analog input signals to digital and vice versa. The signal level equals 10V in and out with a resolution of 12 bits including characters. The board is supplied with $\pm 15V$, either internally or externally. The analog side of the board is galvanically insulated from the system. The first output, is the current output, which can drive or sink a current of 20 mA. The board has a test input/output on the front panel and a test switch which can be used to test whether the board is working properly. By turning the test switch to the position for measuring inputs, a power supply can be connected to the test terminal (protecting resistance should be used in the serial channel) to test whether the inputs are working properly.

If **replaced**, there are no adjustments or procedures required.

The I/O window can be used to check the status of the inputs and outputs. Outputs can be controlled manually and inputs can be read from the I/O window. Common causes of errors are cable faults or faults in external equipment. If none of the channels work, check that the internal or external $\pm 15V$ supply is OK and correctly connected. If the red F-LED is lit, the board is probably faulty or the system parameters are incorrect (i.e. the board is not defined). Refer to the Manual Operation (page 11-19) in this chapter.

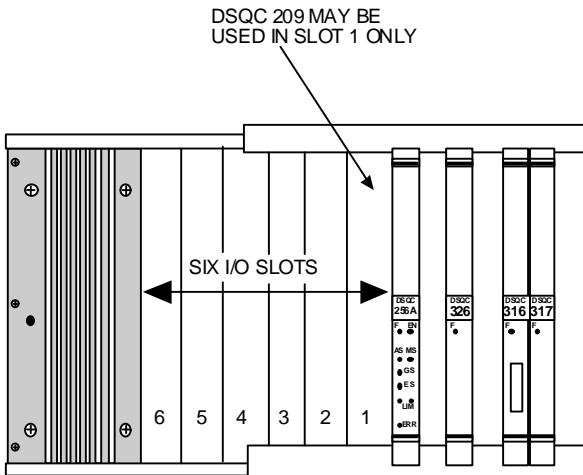

11.2.3 Combined I/O Board DSQC 315

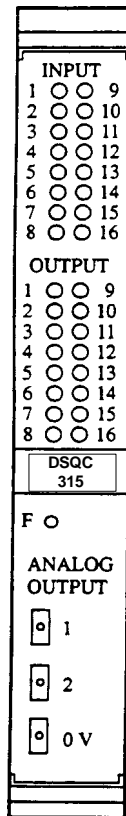

<u>Designation</u>	<u>Color</u>	<u>Description</u>
INPUT	Yellow	See digital I/O board (p11-4).
OUTPUT	Yellow	See digital I/O board (p11-4).
F	Red	Turns off when the board approves the initialization.
1	Measuring	CH1, 0 - +10V terminal
2	Measuring	CH2, 0 - +10V terminal
0V	Measuring	0V

The Combined I/O board may only be used in the first I/O slot. This means that only one combined I/O board can be used per system.

The Combined I/O, DSQC 315, is equipped with 16 digital inputs, 16 digital outputs (see DSQC 223) and 2 analog outputs 1-10V (see DSQC 209). See digital I/O and analog I/O specification and tips. Refer to the Manual Operation (p11-19) in this chapter.

DSQC 315 MAY BE USED IN SLOT 1 ONLY

If **replaced**, there are no adjustments or procedures required.

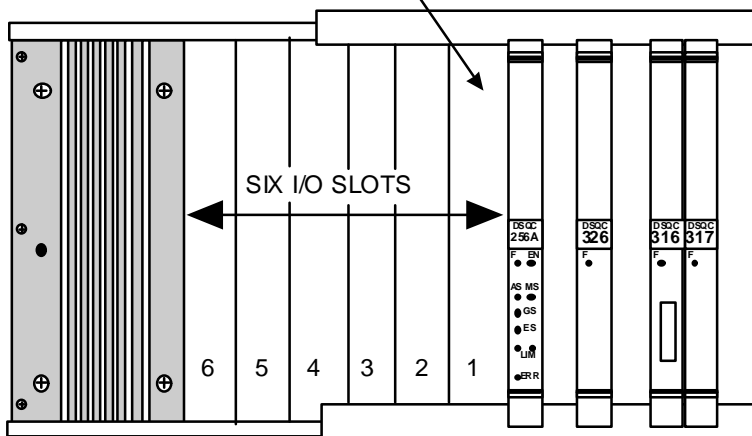

11.2.4 Remote I/O Board DSQC 239

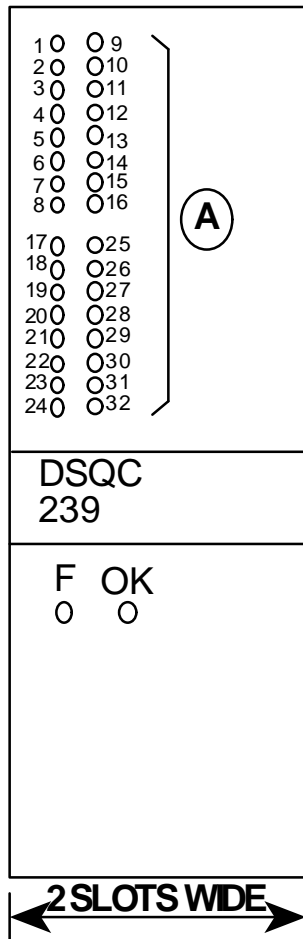

Symptom Description

Source of Fault

A: 32 yellow LEDs indicate the status for the first 16 inputs and 16 outputs.

Robot computer board, rear plane, internal fault in the unit, cabling, or system parameters.

LEDs

RED	GREEN	
F	ACTIVE (OK)	
OFF	ON	Normal indication, Node Adapter fully operational
ON	ON/OFF	Node adapter board not properly initiated, probable cause: - Board faulty - Incorrect I/O-type parameter
ON/OFF	OFF	No communication with host processor, probable cause: - Incorrect parameters for RIO-board - Incorrect wiring - Host processor fault
ON/OFF	BLINK	Bad Communication, probable cause: - Host Processor in Program mode - Reversed connections

DSQC 239 MAY BE USED IN SLOTS 2-6 ONLY

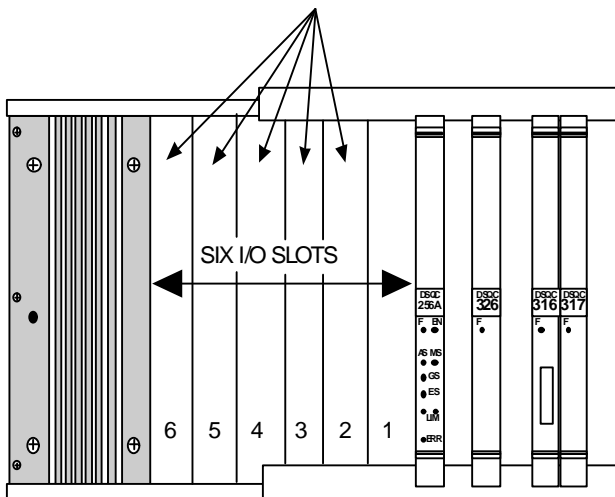

The RIO board is a wide board taking up two I/O slots. When this board is configured it is always in the left of the two slots being occupied by this board.

The serial I/O interface, DSQC 239 (RIO), is intended to be used for communication with Allen-Bradley PLC equipment. The board is equipped with 32 yellow LEDs (which indicate the status of the first 16 inputs and outputs on the front panel), a red F-LED and a green LED, "ACTIVE".

If the green LED is not lit and the red one goes OFF, the board's special communication circuit is probably faulty.

If **replaced**, there are no adjustments or procedures required.



11.3 Board Connections

Board Connectors

The ABB Robot system has several different I/O connection options available. The type of connector depend upon the customer requirements. The following chart shows the different type of I/O boards in their allowed slots. Then the different I/O options and connector labels for the different I/O board positions.

Type Board	Slot Position	Board Conn.	External Conn	Internal Conn	Relay Unit Conn	120 VAC Conn
Analog	1	AP11	XS10	XT10	--	--
Digital	1	AP11	XS11	XT11	AP21	AP21
Digital	2	AP12	XS12	XT12	AP22	AP22
Digital	3	AP13	XS13	XT13	AP23	AP23
Digital	4	AP14	XS14	XT14	AP24	AP24
Digital	5	AP15	XS15	XT15	AP25	AP25
Digital	6	AP16	XS16	XT16	AP26	AP26
Combined I/O	1	AP11	--	--	--	--
Analog part	--	--	XS10	XT10	--	--
Digital part	--	--	XS11	XT11	AP21	AP21
RIO	2-6	AP12-AP16	--	XT17	--	--

11.3.1 External I/O Connections (Conn. option 31X)

Sheet 19.1 (Inputs)..... 
Sheet 20.1 (Outputs).... 
Sheet 21.1 (Analog)..... 

The External I/O Connection option consists of taking the ribbon cable from the back of the I/O board to the side of the control cabinet. The connector on the side of the control cabinet is a standard 64 pin female connector. The labeling of the connector will be XS10 through XS16. Connector XS10 is for analog I/O and connectors XS11 through XS16 are for digital I/O.

The wiring of external I/O connections will be done through a 64 pin male connector on the left side of the control cabinet to the devices to be wired. This type of connector is used for both analog and digital I/O connections.

Each group of eight digital inputs and outputs are galvanically isolated which means that each group of 8 can have a different source voltage. All groups can also be supplied by the same source voltage if desired.

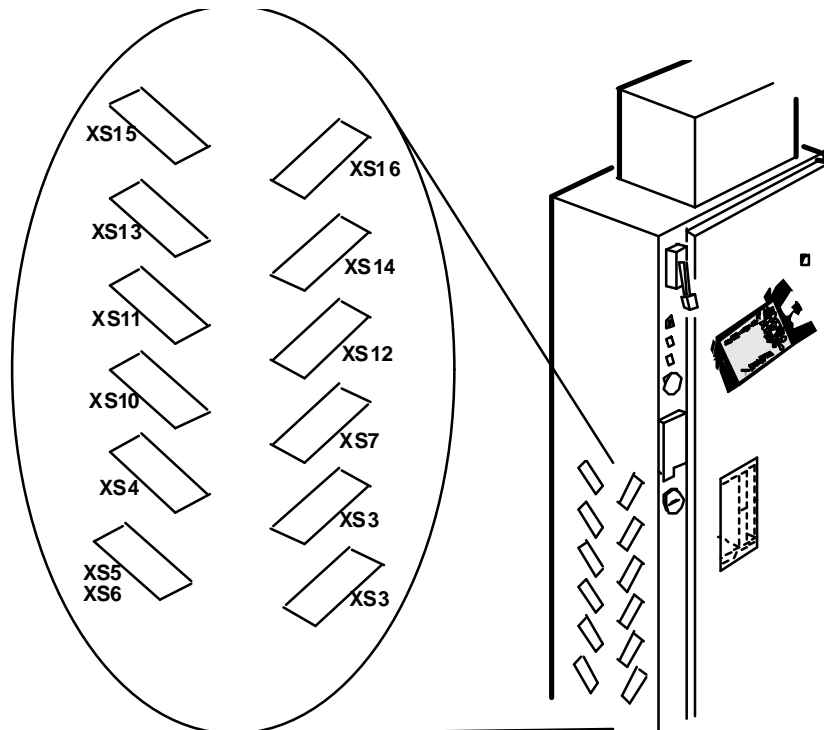

External I/O Connections (Option 31X) (Cont)

The following are examples of how to wire to these pins/ terminals. In the examples below the term XSXX is indicating a socket (XS) and a number (XX). The number (XX) depends upon which I/O board is being used.

Sheet 6, line 01
Sheet 19.1, line 04.....

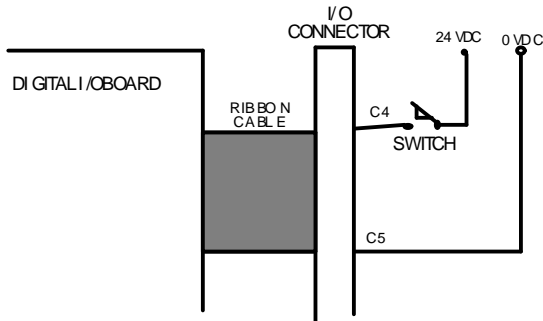

Sheet 20.1, line 10.....

Example: Digital Input

If establishing a digital input, a limit switch is to be wired to input number 6 on an I/O board, the limit switch must have 24 VDC supplied to one side of the limit switch. (Possibly from XS3/XT3 terminals A15-A16 or B15-B16 or C16) The other side of the limit switch would be wired to XSXX pin C4. For the input to work, 0 VDC (of the source voltage) would have to be connected to XSXX pin B5. If inputs 9 - 16 are to be used, 0 VDC must also be connected to pin D7.

Example: Digital Output

If a light is to be wired to output 12 on an I/O board. The light would have 0 VDC connected to one side of it and the other side would be wired to XSXX pin C11. For the output to work 24 VDC and 0 VDC must be supplied to this group of outputs. This can be done by wiring 24 VDC from XS3/XT3 to XSXX pin C10 and 0 VDC on the XSXX pin D12.

Sheet 22, line 01
Sheet 22, line 07

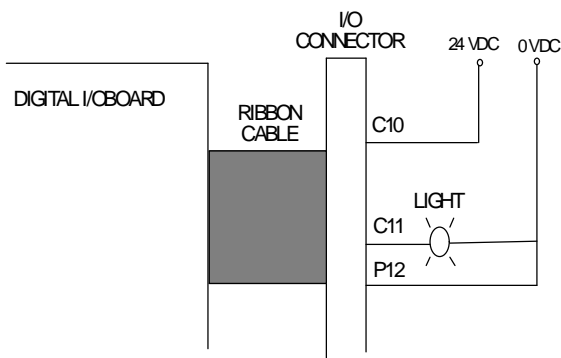

Example: Analog Input

For the analog *inputs* to work, a source voltage (+/- 15 VDC) must be applied to the board. This voltage can be supplied from the customer source or from the robot source. (Robot source at XS10 pins C11, C12, D11, D12, A12, and B12) If an analog input, such as a pressure device, was to be wired to analog input 1, one side of the device would be fed the source voltage and the other side would be connected to the external connection XS10 pin B3. For the input to work, 0 VDC must be connected to XS10 pin A4.

Example: Analog Output

For the analog *outputs* to work, a source voltage (+/- 15 VDC) must be applied to the board. This voltage can be supplied from the customer source or from the robot source. (Robot source at XS10 pins C11, C12, D11, D12, A12, and B12). If an analog output, such as a flow control device, was to be wired to analog output 3, one side of the flow control device would be wired to XS10 pin B5 and the other side would be wired to 0 VDC. The analog output would also need XS10 pin C5 connected to 0 VDC.

External I/O Connections (Option 31X) (Cont)

Digital Inputs Technical Data:

- Optically isolated
- Rated voltage supply:
24 VDC (19 - 35 VDC)
- Logical voltage levels:
"1" 15 - 35 VDC
"0" 0 - 5 VDC
- Input current at rated input voltage:
5.5 mA
- Maximum potential difference:
500V
- Time intervals:
< or = 8ms (hardware)
plus 1-11ms (software)
- System board time intervals:
< or = 1.5 ms (hardware)
plus <2ms (software)

Digital Outputs Technical Data:

- Optically isolated and short circuit protected
- Voltage supply:
24 VDC (19 - 35 VDC)
- Minimum voltage drop on output:
2 V
- Load per output:
200 mA
- Load per group of 8 outputs:
1 A
- Maximum potential difference:
500 V
- Time intervals:
<150 ms (hardware)
plus <2 ms (software)

External I/O Connections (Option 31X) (Cont)

Analog Inputs Technical Data:

- Two with switching frequency:
10 Hz for the input filter
- Two with switching frequency:
100 Hz for the input filter
- Input impedance:
1 Megohm
- Input voltage:
+10 V
- Resolution:
10 mV (10 / 1024)
- Accuracy:
15 mV plus .2% of input signal
- Maximum potential difference:
500 V

Analog Outputs Technical Data:

VOLTAGE OUTPUTS

- Output voltage:
Analog board: +10 V
Combi. board: 0 to +10 V
- Load:
>2K Ohms
- Resolution:
10 mV (10 / 1024)
- Accuracy:
25 mV +0.5% of output signal
- Maximum potential difference:
500 V

CURRENT OUTPUT

- Output current:
+20 mA
- Load:
.450 ohm
- Resolution:
20 mA (20 / 1024)
- Accuracy:
60 mA plus 0.5% of output current
- Maximum potential difference:
500 V

11.3.2 Internal I/O Connections (Conn. option 34X)

The Internal I/O Connection option consists of taking the ribbon cable from the back of the I/O board to a board in the back of the controller. This board breaks out the ribbon cable to individual terminals. The I/O that is run through this board is 24 VDC or less. This same board is used for wiring of analog signals.

Sheet 6, line 01

Sheet 19.1, line 04.....

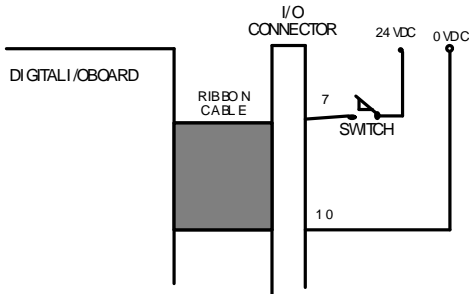

Sheet 20.1, line 10.....

Example: Digital Input

If establishing a digital input, a limit switch is to be wired to input number 6 on an I/O board. The limit switch must have 24 VDC supplied to one side of the limit switch. (Possibly from XS3/XT3 terminals A15-A16 or B15-B16 or C16) The other side of the limit switch would be wired to XTXX terminal 7. For the input to work, 0 VDC (of the source voltage) would have to be connected to XTXX terminal 10. If inputs 9 - 16 are to be used, 0 VDC must also be connected to terminal 20.

Example: Digital Output

If a light is to be wired to output 12 on an I/O board, it would have 0 VDC connected to one side, and the other would be wired to XTXX terminal 35. For the output to work, 24 VDC and 0 VDC must be supplied to this group of outputs. This can be done by wiring 24 VDC from XS3/XT3 to XTXX terminal 31, and 0 VDC on the XSXX terminal 40.

Sheet 22, line 01

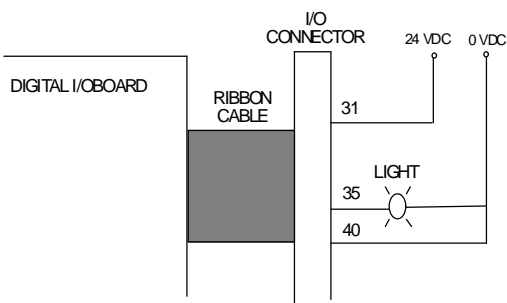

Sheet 22, line 07

Example: Analog Input

For the analog inputs to work, a source voltage (+/- 15 VDC) must be applied to the board. This voltage can be supplied from a customer source or from a robot source. (Robot sources at XT10 pins 35, 36, 37, 38, 39, and 40) If an analog input, such as a pressure device, is to be wired to analog input 1, one side of the device would be fed the source voltage, and the other connected to the XT10 terminal 2. For the input to work, 0 VDC must be connected to XT10 terminal 5.

Example: Analog Output

For the analog outputs to work, a source voltage (+/- 15 VDC) must be applied to the board. This voltage can be supplied from a customer source or from a robot source. (Robot sourced at XT10 terminals 35, 36, 37, 38, 39 and 40). If an analog output, such as a flow control device, is to be wired to analog output 3, one side of the flow control device would be wired to XT10 terminal 10, and the other wired to 0 VDC. The output would also need XT10 terminal 11 connected to 0VDC.

Internal I/O Connections (Option 34X)(Cont)

Digital Inputs Technical Data:

- Optically isolated
- Rated voltage supply:
24 VDC (19 - 35 VDC)
- Logical voltage levels:
"1" 15 - 35 VDC
"0" 0 - 5 VDC
- Input current at rated input voltage:
5.5 mA
- Maximum potential difference:
500V
- Time intervals:
< or = 8ms (hardware)
plus 1-11ms(software)
- System board time intervals:
< or = 1.5 ms (hardware)
plus <2ms (software)

Digital Outputs Technical Data:

- Optically isolated and short circuit protected
- Voltage supply:
24 VDC (19 - 35 VDC)
- Minimum voltage drop on output:
2 V
- Load per output:
200 mA
- Load per group of 8 outputs:
1 A
- Maximum potential difference:
500 V
- Time intervals:
<150 ms (hardware)
plus <2 ms (software)

Internal I/O Connections (Option 34X)(Cont)

Analog Inputs Technical Data:

- Two with switching frequency:
10 Hz for the input filter
- Two with switching frequency:
100 Hz for the input filter
- Input impedance:
1 Megohms
- Input voltage:
+10 V
- Resolution:
10 mV (10 / 1024)
- Accuracy:
15 mV plus .2% of input signal
- Maximum potential difference:
500 V

Analog Outputs Technical Data:

VOLTAGE OUTPUTS

- Output voltage:
Analog board: +10 V
Combi. board: 0 to +10 V
- Load:
>2K Ohms
- Resolution:
10 mV (10 / 1024)
- Accuracy:
25 mV +0.5% of output signal
- Maximum potential difference:
500 V

CURRENT OUTPUT

- Output current:
+20 mA
- Load:
.450 ohm
- Resolution:
20 mA (20 / 1024)
- Accuracy:
60 mA plus 0.5% of output current
- Maximum potential difference:
500 V

11.3.3 Relay Unit (Conn. option 37X)

The relay unit is used only for digital I/O boards. The ribbon cable from the back of the I/O board goes to the relay unit. This option is used when higher current or voltage is required from the outputs. The inputs are not separated on this board.

Example: **Digital Input**

If establishing a digital input, a limit switch is to be wired to input number 6 on an I/O board. The limit switch must have 24 VDC supplied to one side of the limit switch. (Possibly from XS3/XT3 terminals A15-A16 or B15-B16 or C16) The other side of the limit switch would be wired to XT1 terminal 206. For the input to work, 0 VDC (of the source voltage) would have to be connected to XT1 terminal U1. If inputs 9 - 16 are to be used, 0 VDC must also be connected to terminal U2.

Sheet 19.2, line 05..... 

Sheet 20.3, line 08..... 

Example: **Digital Output**

If a light is to be wired to output 12 on an I/O board, the light would have 0 VDC connected to one side, and the other would be wired to XT1 terminal 124. For the output to work, the voltage source and 0 V must be supplied to this group of outputs. This can be done by wiring the source to XT1 terminal 121.

11.3.2 Relay Unit (Conn. option 37X)

Digital Inputs Technical Data:

- Optically isolated
- Rated voltage supply:
24 VDC (19 - 35 VDC)
- Logical voltage levels:
"1" 15 - 35 VDC
"0" 0 - 5 VDC
- Input current at rated input voltage:
5.5 mA
- Maximum potential difference:
500V
- Time intervals:
< or = 8ms (hardware)
plus 1-11ms (software)
- System board time intervals:
< or = 1.5 ms (hardware)
plus <2ms (software)

Digital Outputs Technical Data:

- Optically isolated and short circuit protected
- Voltage supply:
24 VDC (19 - 35 VDC)
- Minimum voltage drop on output:
2 V
- Load per output:
200 mA
- Load per group of 8 outputs:
1 A
- Maximum potential difference:
500 V
- Time intervals:
<150 ms (hardware)
plus <2 ms (software)

Digital Outputs Technical Data:

- Load per output:
4 A
- Load per group of 8 outputs:
6.3 A
- Voltage range (source):
250 VAC

11.3.4 120 VAC Modules (Conn. option 35X)

The 120 VAC board is used only for digital I/O boards. The ribbon cable from the back of the I/O board goes to the 120 VAC board. Both inputs and outputs are controlled by replaceable solid state modules on this board.

Sheet 19.3, line 06..... 

Example: **Digital Input**

If a digital input is to be established, a limit switch will be wired to input number 6 on an I/O board. The limit switch must have 120 VAC supplied to one side of the limit switch. The other side of the limit switch will be wired to XTXX terminal 43. For the input to work, 0 V (of the source voltage) would have to be connected to XTXX terminal 44. Each input has a separate neutral connected on each of the even numbered terminals.

Sheet 20.4, line 12..... 

Example: **Digital Output**

If a light is to be wired to output 12 on an I/O board, the light would have 0 V connected to one side, and other side would be wired to XTXX terminal 24. For the output to work, 120 VAC must be supplied to the output. This can be done by wiring 120 VAC to XTXX terminal 23.

Digital Inputs Technical Data:

- Voltage range:
 90 - 140 VAC
- Input current:
 <8 mA

Digital Outputs Technical Data:

- Load per output:
 1.25 A
- Voltage range (source):
 24 - 140 VAC
- Frequency range (source):
 25 - 70 Hz
- Maximum potential difference:
 2 kV

11.3.5 Manually Operated I/O

The status of the inputs and outputs can be monitored. Also, the outputs can be controlled manually from the teach pendant. To look at I/O status, press:

I/O WINDOW
VIEW
ALL SIGNALS

The following will be displayed:

File	Edit	View
Inputs / outputs		
All Signals		
Name	Value	Type
di1	0	DI
di10	0	DI
di11	0	DI
di12	0	DI
di13	0	DI
di14	0	DI
di15	0	DI
di16	0	DI
di17	0	DI
di18	0	DI

From this display you can see that input 15 is ON.

If the cursor-down or page-down button is pressed, the display will scroll down showing all other inputs and eventually outputs also. The I/O will be displayed in alphanumeric order, which means that 11 comes after 1. When you scroll down through the list to the outputs, you are allowed to change the status on the outputs. By pressing the “0” function button, the selected output will be turned OFF. By pressing the “1” function button the selected output will be turned ON.

The following figure shows the display on the screen.

File	Edit	View
Inputs / outputs		
All Signals		
Name	Value	Type
do1	0	DI
do10	0	DI
do11	0	DI
do12	0	DI
do13	0	DI
do14	0	DI
do15	0	DI
do16	0	DI
do17	0	DI
do18	0	DI

0 1

NOTES

11.4 Component Cross Reference

Component Name	Component Location	Circuit Diagram Number	Location Figure
XS3/XT3	Control, back	Sheet 6	11-1
Digital I/O board DSQC 223	Swing gate, front	Sheet 19.1 through Sheet 20.1	11-4
Analog I/O board DSQC 209	Swing gate, front	Sheet 22	11-4
Combi I/O board DSQC 315	Swing gate, front	Sheet 21.1 and Sheet 21.2	11-4
Remote I/O board DSQC 209	Swing gate, front	Sheet 23	11-4
External connections(Conn. option 31X)	Control, back	Sheet 19.1 through Sheet 20.1	11-9
Internal connections(Conn. option 34X)	Control, back	Sheet 19.1 through Sheet 20.1	11-2
Relay unit (Conn. options37X)	Control, back	Sheet 19.2 and Sheets 20.2 &20.3	
120 VAC Modules(Conn. option 35X)	Control, back	Sheet 19.3 and Sheet 20.4	11-3

NOTES

11.5 List of Circuit Diagrams

1.	POWER SUPPLY +24 VDC, +5VDC	6 of 43
2.	I/O BOARD POSITION	18 of 43
3.	DIGITAL I/O BOARD., COMBI, I/P PART	19.1 of 43
4.	RELAY UNIT, I/P 1-16	19.2 of 43
5.	120 VAC INPUT	19.3 of 43
6.	DIGITAL PART OF COMBI I/O, I/P PART	19.4 of 43
7.	DIGITAL I/O BOARD, INPUT PART	19.5 of 43
8.	DIG. COMBI, DIG. I/O BD. O/P PART	20.1 of 43
9.	RELAY UNIT, OUTPUT 1-8	20.2 of 43
10.	RELAY UNIT, OUTPUT 9-16	20.3 of 43
11.	120 VAC OUTPUT	20.4 of 43
12.	DIG. PART OF COMBI I/O, O/P PART	20.5 of 43
13.	DIGITAL I/O BOARD, OUTPUT PART	20.6 of 43
14.	COMBI I/O BD. ANALOG, O/P PART	21.1 of 43
15.	COMBI I/O BD. ANALOG, O/P PART	21.2 of 43
16.	ANALOGUE I/O BOARD	22 of 43
17.	REMOTE I/O BOARD FOR A-B PLC	23 of 43

NOTES

Figure 11-1 XS3/XT3

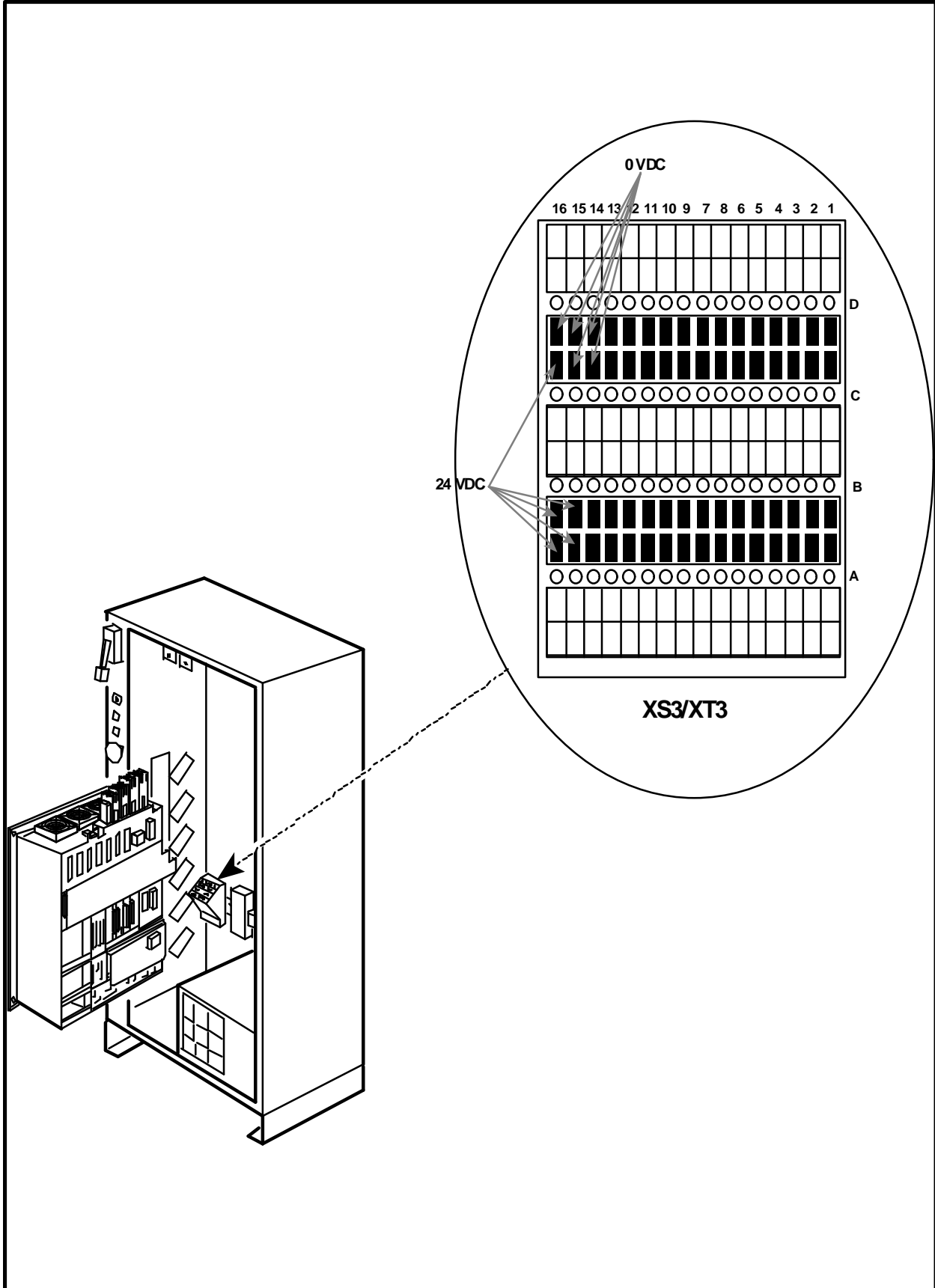

NOTES

Figure 11-2 Screw Terminals

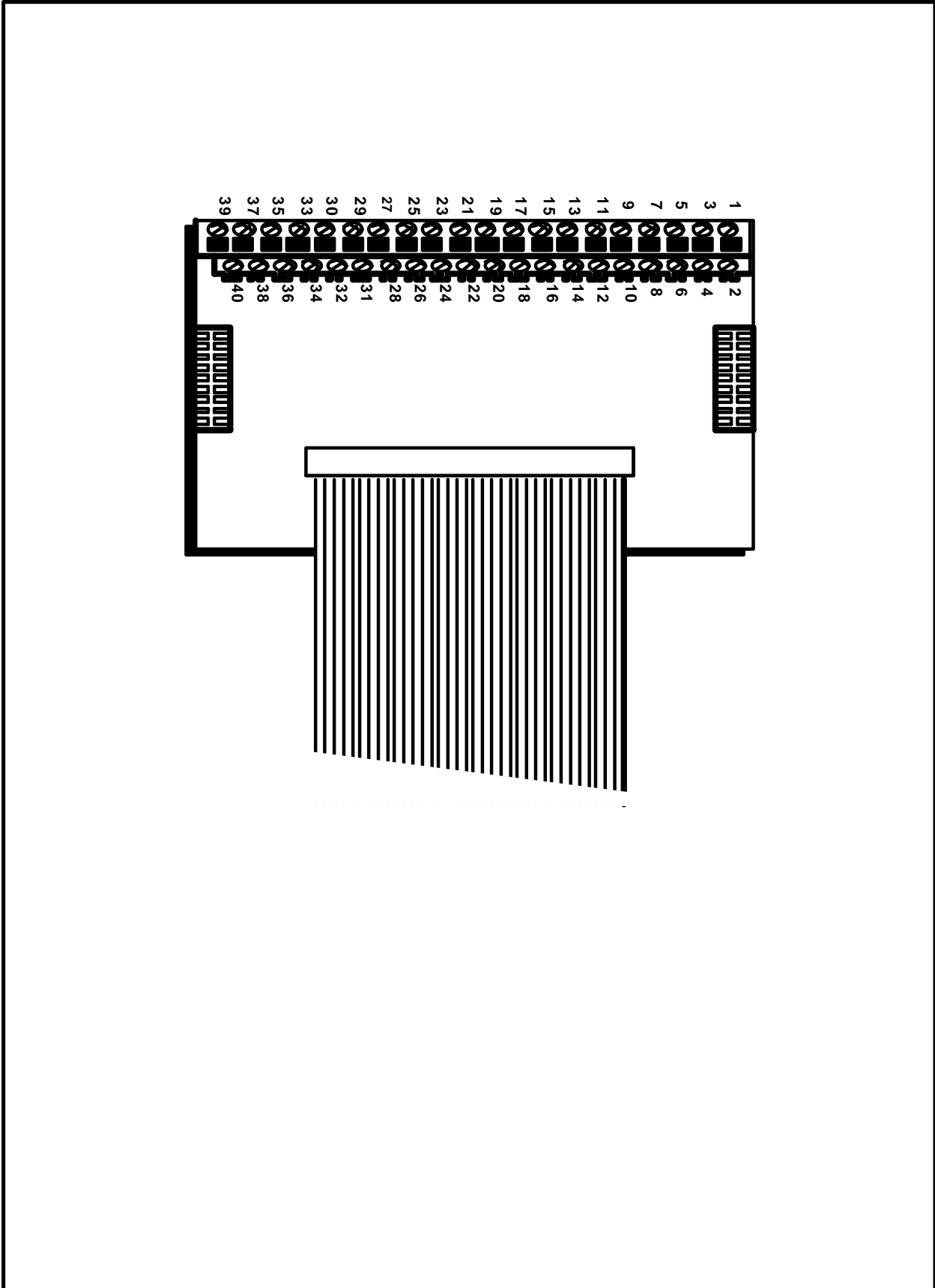

NOTES

Figure 11-3 120 VAC I/O Connector

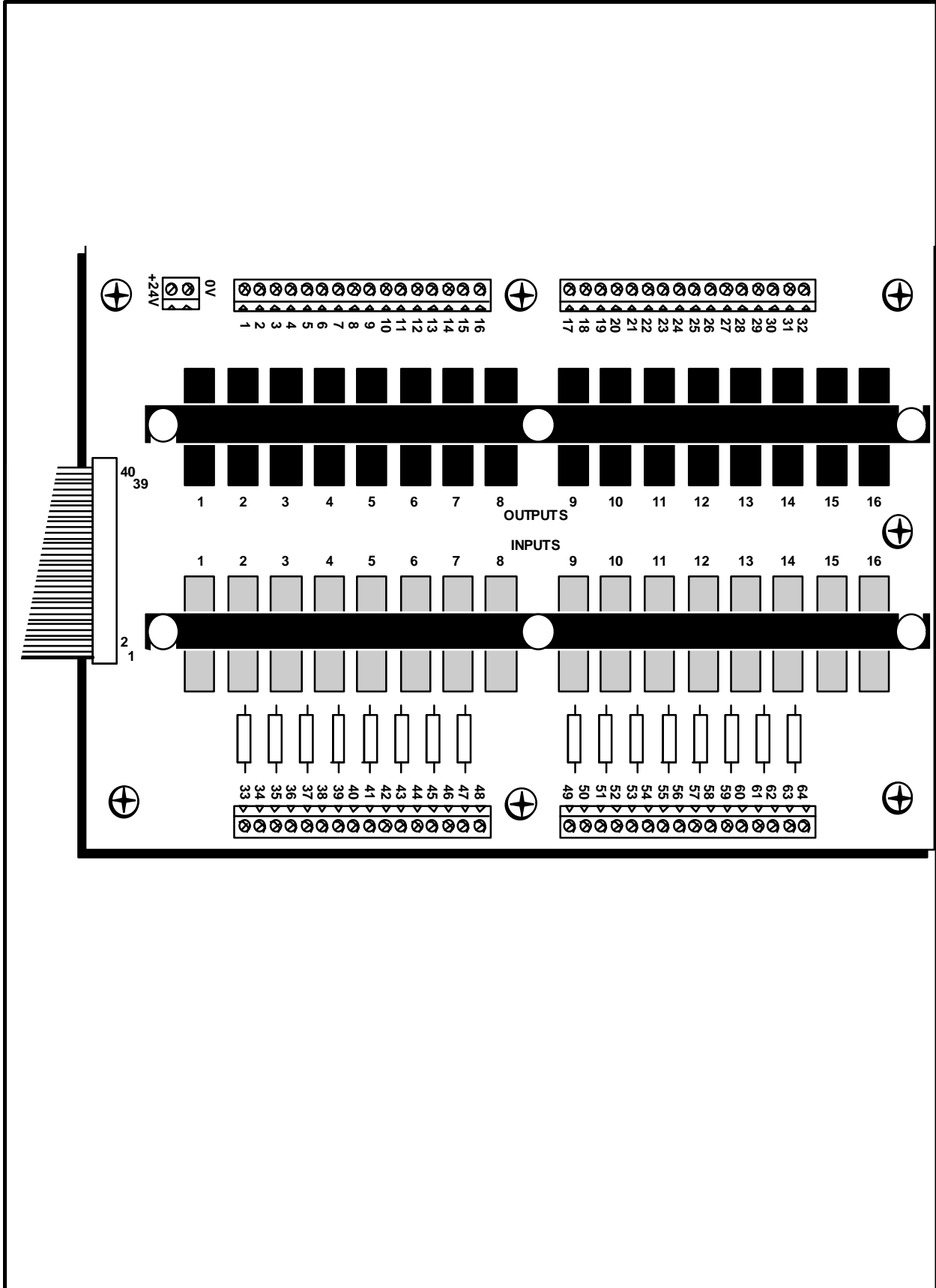

NOTES

APPENDIX A

ERROR MESSAGES

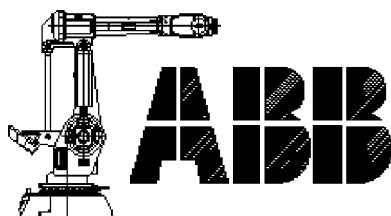

Error Messages

Table of Contents

A.	ERROR MESSAGES.....	A-2
A1.	Indicating Errors	A-2
A2.	Types of Error Messages	A-3
A3.	Error Codes	A-7
A3.1	Operational Error Messages	A-7
A3.2	System Error Messages	A-9
A3.3	Hardware Error Messages	A-16
A3.4	Programming Error Messages	A-35
A3.5	Motion Error Messages	A-59
A3.6	Operator Error Messages	A-67
A3.7	I/O & Communication Error Messages	A-69

Error Messages

A. ERROR MESSAGES

A1. Indicating Errors

When an error in the system occurs, the Error Code Number, Category and Reason will show in the message window of the Teach Pendant.

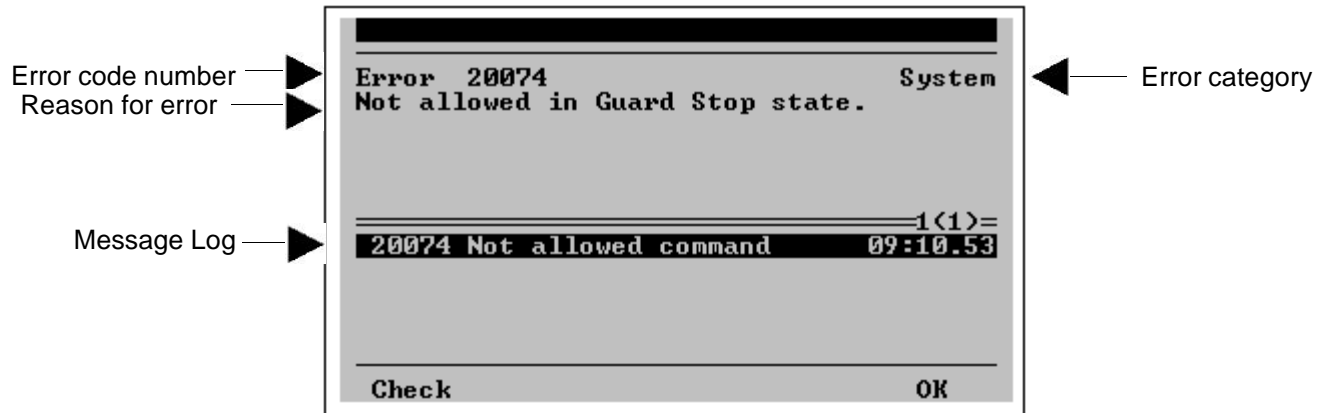

Below are descriptions of the information that will be displayed:

Error Code Number

A number that is unique for each error.

Error Category

Connects the error to the category of that type of error, e.g. Hardware.

Reason

Describes the reason for the error in plain language. See the next section of this manual for more information on hardware errors.

Message Log

The 50 most recent errors are displayed in the message log. The error shown on the first line is the last error to be displayed in the window. The log indicates the error code number, a short explanation of the error and the time at which the error was registered. If any of the messages in the log are

A2. Types of Error Messages

Error messages are divided into three degrees of importance:

- State Change
- Warning
- Error

CHANGE OF STATE:

The Change of State message is given whenever the Mode Selector Key Switch is changed from Manual Reduced to Auto Mode or from Manual Reduced to Manual Full Speed mode. When this message is displayed the operator is required to press the **OK** button to acknowledge the change of state or press the **CANCEL** button which will cause a message indicating that the key switch must be changed to another mode. The purpose for this message is for safety. This is known as "single point of control". This means if a programmer is in the work cell with the teach pendant, the programmer is notified through the teach pendant that the control has been switched to a full speed mode. The programmer then has the choice of approving this change of state.

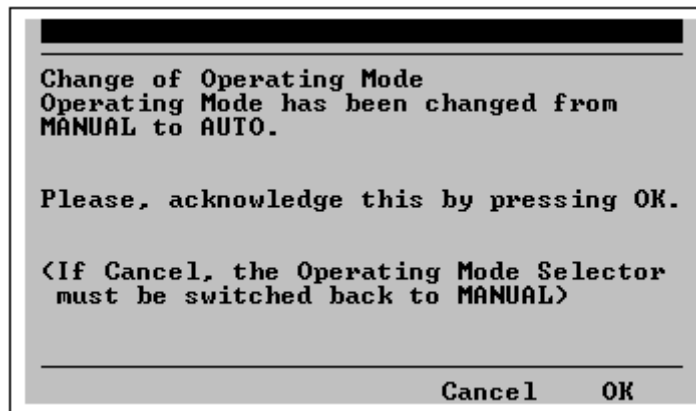

Change of State Message

Types of Error Messages (Cont)

WARNING:

A warning message is displayed to let the programmer know that what they are trying to do is irreversible and may not be wanted. A warning is like a second chance for the programmer to abort from what is about to happen. Warnings are only given while pressing buttons on the teach pendant. There are two responses to a warning:

"YES" which acknowledges that this is correct and continue.

"NO" which indicates that this is not what you want to happen. Warnings can also

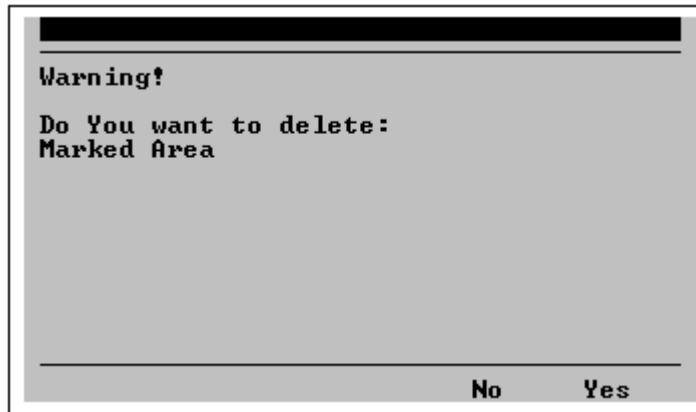

Warning Message

Types of Error Messages (Cont)

ERROR:

An error message is generated when the computer has decided there is a problem with the system. There are several different error types.

The error types are divided into six groups:

1xxxx	Operational:	Robot operations
2xxxx	System:	Internal software events
3xxxx	Hardware:	Hardware events
4xxxx	Program:	RAPID program execution
5xxxx	Motion:	Motion-related events
6xxxx	Operator:	Handling the teach pendant

When an error message is displayed, an error number is displayed along with the type of error on the top line of the display. Also displayed will be a basic description of the error. The bottom part of the screen displays all errors that occurred. (sometimes multiple errors will occur at the same time.) When an error is generated, there are two things that you can do:

First you can press **“CHECK”** (giving a more detailed explanation of the error.)
Second you can press **“OK”** (acknowledging the error and clearing the message from the screen. (You **must** press **“OK”** to clear **all** error messages.)

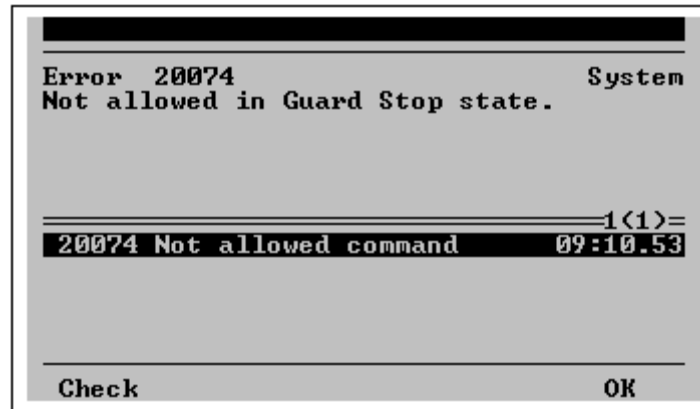

Error Message

Types of Error Messages (Cont)

An ERROR LOG can be accessed to show a history of error messages that have occurred in the system. To look at the error log, press the MISC button, then choose SERVICE. The error log should appear. If not, press the VIEW button, then choose LOG. The log is divided into several categories. The first is the common log which records the last 50 messages of all types. The rest are the different categories of errors along with the number of errors in the log and the date and time of the latest error. A detailed list of errors is obtained by moving the cursor to the category that you want and pressing ENTER.

File Edit View Special			
Service Log			
Name	Messages		
	#	Latest	
Common	13	0812 09:10.53	1(12)=
Operational	12	0812 08:52.48	
System	1	0812 09:10.53	
Hardware	0		
Motion	0		
Program	0		
Operator	0		
IO & Communication	0		

Msg→

Error Log

A3. Error Codes

A3.1 Operational Error Messages

These are messages that indicate the operational status of the Control. The operational messages have the following error codes : 10000 to 19999.

10005: Program stopped

The task instance %f has stopped. The reason code is %f. This means that %s:

- 15001: the task has reached an exit statement
- 15002: the task is ready
- 15003: the task is ready with this step
- 15004: the task has reached a break statement
- 15005: an external or internal stop has occurred
- 15006: an error has occurred
- 15007: Cannot execute backward past beginning of statement list
- 15008: Cannot execute backward past structured statement

10007: Program started

The task instance %f has started the execution. The originator is %f.

10008: Program restarted

The task instance %f has restarted the execution. The originator is %f.

10009: Program heap full

Memory overflow in program instance %f. Check: Save the program then restart it.

10010: Motors off state.....Chapter 5

10011: Motors on state.....Chapter 5

10012: Guard stop state.....Chapter 5

Run chain opened by any safety guard except the emergency stop.

10013: Emergency stop state.....Chapter 5

Runchain opened by emergency stop. Emergency stop reset is required. Use the motors off button.

10014: System failure state.....Chapter 2

Fatal non recoverable system error. Warm start is required.

Error Messages

Operational Error Messages (Cont)

- 10015: Manual mode selected.....Chapter 5
- 10016: Automatic mode requested.....Chapter 5
- 10017: Automatic mode confirmed.....Chapter 5
- 10018: Manual mode FS requested.....Chapter 5
- 10019: Manual mode FS confirmed.....Chapter 5
- 10020: Execution error state.....Chapter 2
- 10021: Execution error reset.....Chapter 2
- 10030: All axes commutated.....Chapter 10
- 10031: All axes calibrated.....Chapter 10
- 10032: All rev counters updated.....Chapter 10
- 10033: All axes synchronized.....Chapter 10
- 10034: Axis not commutated.....Chapter 10
- 10035: Axis not calibrated.....Chapter 10
- 10036: Rev counter not updated.....Chapter 10
- 10037: Axis not synchronized.....Chapter 10
- 10040: Program loaded
- The program instance %.f has loaded a program.
- 10041: Program erased
- The program instance %.f has erase a program.
- 10043: Restart failed
- The program instance %.f can't restart the program server.
- 10044: Program PP updated
- The program instance %.f could have change the PP pos.
- 10045: System restarted

A3.2 System Error Messages

These are system errors that are detected by the system software. The system error messages have the following error codes : 20000 to 29999.

20001: Enable chain open.....Chapter 2

The enable chain is open.
Check the system board LED's for an indication to what has the enable chain open.

20002: Emergency stop.....Chapter 6

There is an emergency stop in the system.
Check the system board LED's for an indication to what has the enable chain open.

20003: Limit stop.....Chapter 5

There is a limit stop in the system.

20006: Auto stop.....Chapter 5

There is a auto stop in the system.

20007: Manual stop.....Chapter 5

There is a Manual stop in the system.

20008: General stop.....Chapter 5

There is a general stop in the system.

20009: Run chain status fault.....Chapter 5

Two channel status conflict.
There is a run chain status fault in the system.

20011: Em stop state active.....Chapter 6

Emergency stop reset is required. Use the MOTORS OFF button.

20012: Sys failure state active.....Chapter 2

Fatal non-recoverable system error. Warm start is required. Switch the mains switch OFF and ON again if the soft restart command is ignored or not possible to reach.

Error Messages

System Error Messages (Cont)

20020: Run chain status timeout.....Chapter 5

Two channel status timeout. The acknowledgement for a two channel run chain status change was not received within the expected time.

20021: Key speed status fault.....Chapter 5

The operating mode selector signals and the speed signal are in conflict.

20022: Key status fault.....Chapter 5

The operating mode selector signals are in conflict (i.e. several modes or no mode indicated).

20024: Enable chain status timeout

Two channel status timeout.
The acknowledgement for a two channel enable chain status change was not received within the expected time.

20025: Stop order timeout

The stop order was carried out as a force guard stop when no acknowledgement was received within the expected time.

20030: Axis not commutated.....Chapter 10

One or several internal drive unit axes are not commutated.

20031: Axis not calibrated.....Chapter 10

One or several absolute/relative measurement axes are not calibrated.

20032: Rev counter not updated.....Chapter 10

One or several absolute measurement axes are not synchronized.

20033: Axis not synchronized.....Chapter 10

One or several relative measurement axes are not synchronized.

20040: Hold stop

20041: Motor 1-6 overload.....Chapter 9

20042: Motor 7-x overload.....Chapter 9

System Error Messages (Cont)

20050: Not allowed command

Not allowed in this operating mode.

20051: Not allowed command

Not allowed when client not in control of the resource (program/motion).

20052: Not allowed command

Not allowed in this cabinet state.

20053: Not allowed command

Not allowed in this manipulator state.

20054: Not allowed command

Not allowed when program is executing.

20060: Not allowed command.....Chapter 5

Not allowed in Auto mode.

20061: Not allowed command.....Chapter 5

Not allowed when changing to Auto mode.

20062: Not allowed command.....Chapter 5

Not allowed in Manual mode.

20063: Not allowed command.....Chapter 5

Not allowed in Manual full speed mode.

20064: Not allowed command.....Chapter 5

Not allowed when changing to Manual full speed mode.

20070: Not allowed command.....Chapter 5

Not allowed in Motors On state.

20071: Not allowed command.....Chapter 5

Not allowed while changing to Motors On state.

Error Messages

System Error Messages (Cont)

20072: Not allowed command.....Chapter 5

Not allowed in Motors Off state.

20073: Not allowed command.....Chapter 5

Not allowed while changing to Motors Off state.

20074: Not allowed command.....Chapter 5

Not allowed in Guard Stop state.

20075: Not allowed command.....Chapter 6

Not allowed in Emergency Stop state.

20076: Not allowed command.....Chapter 2

Not allowed in System Failure state.

20080: Not allowed command.....Chapter 9

Not allowed when axis is not commutated.

20081: Not allowed command.....Chapter 10

1234567890123456789012345678901234567890
Not allowed when axis is not calibrated.

20082: Not allowed command.....Chapter 10

Not allowed when axis rev counter is not updated.

20083: Not allowed command.....Chapter 10

Not allowed when axis is not synchronized.

20100: Teachp (xxx) in ctrl

A teach pendant application is in control of the requested resource (program/motion).

20101: Teachp (prg) in ctrl

The teach pendant programming window has focus and is in control of the program server. Change to the production window and perform the command again.

System Error Messages (Cont)

20102: Teachp (joystick) in ctrl

The teach pendant joystick is in control of the motion server. Release the joystick and perform the command again.

20111: Teachp (prg) in ctrl

The teach pendant programming window has focus and is in control of the program server. Change to the production window and perform the command again.

20112: Pgm (1) in ctrl

The program server (1) is in control of the motion server. Stop the program and perform the command again.

20113: Pgm (2) in ctrl

The program server (2) is in control of the motion server. Stop the program and perform the command again.

20114: Pgm (3) in ctrl

The program server (3) is in control of the motion server. Stop the program and perform the command again.

20115: Pgm (4) in ctrl

The program server (4) is in control of the motion server. Stop the program and perform the command again.

20116: Pgm (5) in ctrl

The program server (5) is in control of the motion server. Stop the program and perform the command again.

20120: System IO in ctrl

20125: Client %s in ctrl

Specified client is in control of the requested resource (program/motion).

20130: Out of memory in cfg

20131: Unable to read file.....Chapter 3

20132: Unable to create file.....Chapter 3

Error Messages

System Error Messages (Cont)

20133: Cannot modify this instance

20140: Motors On rejected.....User's Guide

Motors On via System IO not allowed.

20141: Motors Off rejected.....User's Guide

Motors Off via System IO not allowed.

20142: Start rejected.....User's Guide

Start/restart of program via System IO not allowed.

20143: Start main rejected.....User's Guide

Start of main program via System IO not allowed.

20144: Stop rejected.....User's Guide

Stop of program via System IO not allowed.

20145: Stop cycle rejected.....User's Guide

Stop of program cycle via System IO not allowed.

20146: Man interrupt rejected.....User's Guide

Manual interrupt of program via System IO not allowed.

20147: Load and start rejected.....User's Guide

Load and start of program via System IO not allowed.

20148: Confirm rejected.....User's Guide

Emergency Stop Reset Confirm via System IO not allowed.

20149: Error reset rejected.....User's Guide

Program execution error reset via System IO not allowed.

20150: Synchronization rejected.....User's Guide

Synchronization of mechanical unit via System IO not allowed.

System Error Messages (Cont)

20151: Faulty signal name.....User's Guide

Signal name not possible to subscribe on for Sysio. The Signal name might not be in the cfg-file for Sysio.

20152: To many restrictions.....User's Guide

For an action (signal) in Sysio, no restrictions are set. The total number of restrictions (signals) for an action in the cfg-file for Sysio is to high. Check:

Error Messages

A3.3 Hardware Error Messages

These are direct hardware errors that can occur during diagnostics of the system or during runtime. The hardware errors have the following error codes : 30000 to 39999.

31108: Error in serial channel %.f..... Chapter 2

1. Check communication parameters
2. Replace robot computer board

31114: Bus error when accessing LED on main computerChapter 2

1. Replace main computer board
2. Replace robot computer board

31115: Error in serial channel 1.....Chapter 2

Received data not equal to transmitted data.

1. Check communication parameters
2. Replace robot computer board

31116: Overflow error in serial channel 1..... Chapter 2

1. Check communication parameters
2. Replace robot computer board

31117: Parity error in serial channel 1..... Chapter 2

1. Check communication parameters
2. Replace robot computer board

31118: Framing error in serial channel 1..... Chapter 2

1. Check communication parameters
2. Replace robot computer board

31119: Noise error in serial channel 1..... Chapter 2

1. Check communication parameters
2. Replace robot computer board

31125: Error in serial channel 7.....Chapter 2

Received data not equal to transmitted data.

1. Check communication parameters
2. Replace robot computer board

Hardware Error Messages (Cont)

31126: Overflow error in serial channel 7..... Chapter 2

1. Check communication parameters
2. Replace robot computer board

31127: Parity error in serial channel 7..... Chapter 2

1. Check communication parameters
2. Replace robot computer board

31128: Framing error in serial channel 7..... Chapter 2

1. Check communication parameters
2. Replace robot computer board

31129: Noise error in serial channel 7..... Chapter 2

1. Check communication parameters
2. Replace robot computer board

31130: Port error.....Chapter 2

Replace robot computer board.

31203: Floppy Disk Error.....Chapter 3

Bad floppy disk or not formatted.

31206: Floppy Disk Error.....Chapter 3

Bad floppy disk or internal error.

31210: Floppy Disk Error.....Chapter 3

Invalid format.

31211: Floppy Disk Error.....Chapter 3

Data transfer error to/from floppy.

31214: Floppy Disk Error.....Chapter 3

Data transfer was interrupted.

31215: Floppy Disk Error.....Chapter 3

Internal command invalid.

Error Messages

Hardware Error Messages (Cont)

31216: Floppy Disk Error.....Chapter 3

Floppy disk was moved during transfer.

31217: Floppy Disk Error.....Chapter 3

Bad floppy disk or floppy device.

31219: Floppy Disk Error.....Chapter 3

Floppy device not ready.

31220: Floppy Disk Error.....Chapter 3

Bad floppy disk or internal error.

31221: Floppy Disk Error.....Chapter 3

Data error.

31222: Floppy Disk Error.....Chapter 3

Internal error - Overrun.

31223: Floppy Disk Error.....Chapter 3

Bad floppy or internal error.

31224: Floppy Disk Error.....Chapter 3

Floppy write protected.

31225: Floppy Disk Error.....Chapter 3

Bad Floppy - Address mark missing.

31226: Floppy Disk Error.....Chapter 3

Bad data on floppy.

31227: Floppy Disk Error.....Chapter 3

Bad floppy - Missing cylinder.

31228: Floppy Disk Error.....Chapter 3

Bad floppy - Bad cylinder.

Hardware Error Messages (Cont)

31229: Floppy Disk Error.....Chapter 3

Bad floppy - Bad address mark in data.

31401: DMA transfer error in ROBOT COMPUTER..... Chapter 2

Replace robot computer board.

31402: DMA transfer error in ROBOT COMPUTER..... Chapter 2

Replace robot computer board.

31403: DMA transfer error in ROBOT COMPUTER..... Chapter 2

Replace robot computer board.

31404: DMA transfer error in ROBOT COMPUTER..... Chapter 2

Replace robot computer board.

31405: Prom not including axis program..... Chapter 2

Replace proms on robot computer board.

31406: Memory error in axis computer..... Chapter 2

Replace robot computer board.

31407: Axis computer error.....Chapter 2

Check to see if signal DRVFLT-N is connected. Replace robot computer board.

31408: Axis computer error.....Chapter 2

Replace robot computer board.

31409: Robot computer error.....Chapter 2

Replace robot computer board.

31410: Axis computer error.....Chapter 2

Replace robot computer board.

31411: Axis computer error.....Chapter 2

Replace robot computer board.

Error Messages

Hardware Error Messages (Cont)

31414: Main computer error.....Chapter 2

1. Replace main computer board
2. Replace robot computer board

31415: Main computer error.....Chapter 2

Replace main computer board.

31416: Path computer error.....Chapter 2

Replace path computer board.

31417: Path computer error.....Chapter 2

Replace path computer board.

31418: DMA transfer error in ROBOT COMPUTER..... Chapter 2

Replace robot computer board.

31419: DMA transfer error in ROBOT COMPUTER..... Chapter 2

Replace robot computer board.

31420: DMA transfer error in ROBOT COMPUTER..... Chapter 2

Replace robot computer board.

31421: Error in IO COMPUTER.....Chapter 2

Replace robot computer board.

31501: Battery voltage too low on battery 1..... Chapter 2

Replace battery 1.

31502: Battery voltage too low on battery 2..... Chapter 2

Replace battery 2.

31503: Battery voltage too low on both batteries... Chapter 2

Replace batteries.

31601: Error HI PROM checksum: %.f..... Chapter 2

Checksum should have been: %.f. Replace proms on robot computer board.

Hardware Error Messages (Cont)

31602: Error LOW PROM checksum: %.f..... Chapter 2

Checksum should have been: %.f. Replace proms on robot computer board.

31603: Error PROM checksum: %.f..... Chapter 2

Checksum should have been: %.f. Replace proms on robot computer board.

31605: Memory error in IO-computer..... Chapter 2

Replace robot computer board.

31606: Memory error in IO-computer..... Chapter 2

Replace robot computer board.

31607: Memory error in IO-computer..... Chapter 2

Replace robot computer board.

31701: Serial channel %.f overrun error..... Chapter 2

1. Check communication parameters
2. Replace robot computer board

31702: Serial channel 2 overrun error..... Chapter 2

1. Check communication parameters
2. Replace robot computer board

31703: Serial channel 3 overrun error..... Chapter 2

1. Check communication parameters
2. Replace robot computer board

31704: Serial channel 5 overrun error..... Chapter 2

1. Check communication parameters
2. Replace robot computer board

31705: Serial channel 8 overrun error..... Chapter 2

1. Check communication parameters
2. Replace robot computer board

Error Messages

Hardware Error Messages (Cont)

31706: Serial channel %.f parity error..... Chapter 2

1. Check communication parameters
2. Replace robot computer board

31707: Serial channel 2 parity error..... Chapter 2

1. Check communication parameters
2. Replace robot computer board

31708: Serial channel 3 parity error..... Chapter 2

1. Check communication parameters
2. Replace robot computer board

31709: Serial channel 5 parity error..... Chapter 2

1. Check communication parameters
2. Replace robot computer board

31710: Serial channel 8 parity error..... Chapter 2

1. Check communication parameters
2. Replace robot computer board

31711: Serial channel %.f framing error..... Chapter 2

1. Check communication parameters
2. Replace robot computer board

31712: Serial channel 2 framing error..... Chapter 2

1. Check communication parameters
2. Replace robot computer board

31713: Serial channel 3 framing error..... Chapter 2

1. Check communication parameters
2. Replace robot computer board

31714: Serial channel 5 framing error..... User;'s guide

1. Check communication parameters
2. Replace robot computer board

Hardware Error Messages (Cont)

31715: Serial channel 8 framing error.....Chapter 2

1. Check communication parameters
2. Replace robot computer board

31716: Serial channel %.f error.....Chapter 2

1. Check communication parameters
2. Replace robot computer board

31730: Timer %.f error.....Chapter 2

Replace robot computer board.

31733: Serial channel %.f error.....Chapter 2

Received data not equal transmitted data.

31734: Serial channel 2 error.....Chapter 2

Received data not equal transmitted data.

31735: Serial channel 3 error.....Chapter 2

Received data not equal transmitted data.

31736: Serial channel 5 error.....Chapter 2

Received data not equal transmitted data.

31737: Serial channel 8 error.....Chapter 2

Received data not equal transmitted data.

31738: Timer or Counter %.f error.....Chapter 2

Replace robot computer board.

31742: Serial channel 2 error.....Chapter 2

Handshake error.

31743: Serial channel 3 error.....Chapter 2

Handshake error.

Error Messages

Hardware Error Messages (Cont)

- 31744: Serial channel 5 error.....Chapter 2
Handshake error.
- 31745: Serial channel 8 error.....Chapter 2
Handshake error.
- 31746: Serial channel %.f error.....Chapter 2
Handshake error.
- 31747: Serial channel %.f error.....Chapter 2
Interrupt error.
- 32247: Mailbox 1 interrupt error on IO computer.... Chapter 2
Replace robot computer board.
- 32248: Mailbox 2 interrupt error on IO computer.... Chapter 2
Replace robot computer board.
- 32301: Memory error in MAIN COMPUTER..... Chapter 2
Replace main computer board.
- 32302: Memory error in MAIN COMPUTER..... Chapter 2
Replace main computer board.
- 32303: Memory error in MAIN COMPUTER..... Chapter 2
Replace main computer board.
- 33101: X resolver Error.....Chapter 9
Failure in X resolver signal on channel %.f. X signal is less than noise value.
- 33102: Y resolver Error.....Chapter 9
Failure in Y resolver signal on channel %.f. Y signal is less than noise value.
- 33103: X or Y resolver Error.....Chapter 9
Failure in X or Y resolver signal on channel %.f. Sum of squared X and Y exceeds max.

Hardware Error Messages (Cont)

- 33104: X and Y resolver Error.....Chapter 9**
Failure in X and Y resolver signals on channel %.f. X, Y signals are less than noise value.
- 33105: Resolver Feed Error.....Chapter 9**
Failure in feed signal to resolvers.
- 33106: Drive Unit Offset Error.....Chapter 9**
Drive Unit offset exceeded maximum on channel %.f.
- 33107: Incorrect DC-link type.....Chapter 9**
Physical DC-link type does not match configuration.
- 33108: Incorrect Drive Unit Type.....Chapter 9**
Physical Drive Unit Type for channel %.f does not match configuration.
- 33148: Axis Computer Error.....Chapter 2 & 9**
Axis computer DSP was stopped with hw interrupt due to miscellaneous error.
- 33150: Axis Computer Int Error.....Chapter 2**
Axis computer DSP was stopped with hw interrupt due to interrupt error.
- 33151: Axis DSP Output Overflow.....Chapter 2**
Axis computer DSP was stopped with hw interrupt due to output overflow error.
- 33152: Axis Computer Drive Unit.....Chapter 2**
Axis computer DSP was stopped with hw interrupt due to drive unit error.
- 33153: Axis DSP Tach Overflow.....Chapter 2**
Axis computer DSP was stopped with interrupt due to tachometer register overflow.
- 33154: Axis DSP XY Overflow.....Chapter 2**
Axis computer DSP was stopped with hw interrupt due to X, Y register overflow.
- 33155: Axis DSP RC Overflow.....Chapter 2**
Axis computer DSP was stopped with hw interrupt due to ring controller register overflow.

Error Messages

Hardware Error Messages (Cont)

33156: Transmission failure.....Chapter 2

Contact lost with serial measurement system. Axis computer DSP stopped due to transmission timeout.

33157: Transmission failure.....Chapter 2

Axis computer DSP detected failure in transmission to/from serial measurement system.

33158: Axis DSP Driver Clock.....Chapter 2

Axis computer DSP driver clock failure. Main computer is not responding on request.

33159: Manual Mode Speed Warning.....Chapter 2

Manual mode speed exceeded for the joint connected to axc channel %.f.

33201: Axis cpu Read Error.....Chapter 2

Error in reading from axis computer driver. Axis computer driver did not return correct number of bytes.

33202: Axis cpu Write Error.....Chapter 2

Error in writing to the axis computer driver. Axis computer driver did not return correct number of bytes.

33203: Axis cpu ioctl Error.....Chapter 2

Error in ioctl to the axis computer driver. Fail to execute ioctl command.

33210: Feedback Position Error.....Chapter 2

Driver failed to read feedback position on joint %.f.

33211: Position Control Underrun.....Chapter 2

Unable to complete position control in the allowed time.

33212: DMA Time out Error.....Chapter 2

DMA access failed from main computer to axis computer.

33213: DMA Operation Error.....Chapter 2

DMA Control Operation failed from Main computer to Axis computer.

Hardware Error Messages (Cont)

33220: Axis computer failure

Axis computer has returned an error code indicating DSP hardware failure.

33301: Error in axis computer.....Chapter 2

Replace robot computer board.

33302: Error in axis computer.....Chapter 2

Replace robot computer board.

33303: Error in axis computer.....Chapter 2

Replace robot computer board.

33304: Error in axis computer.....Chapter 2

Replace robot computer board.

33305: Error in axis computer memory..... Chapter 2

Replace robot computer board.

33306: Error in drive unit jumper test..... Chapter 2

33307: Error in drive unit jumper test..... Chapter 2

33308: Error in axis computer.....Chapter 2

Replace robot computer board.

33309: Error in axis computer.....Chapter 2

Replace robot computer board.

33310: Error in axis computer.....Chapter 2

Replace robot computer board.

33311: Axis computer.....Chapter 2

Current ref. loopback error. Replace robot computer board.

Error Messages

Hardware Error Messages (Cont)

33312: Axis computer error.....Chapter 2

RUNNING/DRVFLT signal error.

1. Replace robot computer board
2. Check drive system boards

33313: Ext axis communication jumper error..... Chapter 2

33314: Axis computer error.....Chapter 2

Replace robot computer board.

33315: Axis computer error.....Chapter 2

Replace robot computer board.

37001: Contactor activation Error.....Chapter 5

Motor ON contactor did not activate or Motor ON signal is not distributed through auxiliary contact.

1. Restart system
2. Replace Motor On contactor or auxiliary contact
3. Replace system board

37002: Main computer software not downloaded or not running.
.....Chapter 3

37003: Main computer error.....Chapter 2

Replace main computer board.

37004: Main computer error.....Chapter 2

Replace main computer board.

37005: Main computer error.....Chapter 2

Replace main computer board.

37006: Main computer error.....Chapter 2

Replace main computer board.

37007: Main computer error.....Chapter 2

Replace main computer board.

Hardware Error Messages (Cont)

37008: Main computer error.....Chapter 2

Replace main computer board.

37009: Main computer error.....Chapter 2

Replace main computer board.

37010: Main computer error.....Chapter 2

Replace main computer board.

37011: Main computer error.....Chapter 2

Replace main computer board.

37012: Main computer error.....Chapter 2

Replace main computer board.

37013: Main computer error.....Chapter 2

Replace main computer board.

37014: Main computer error.....Chapter 2

Replace main computer board.

37015: Main computer error.....Chapter 2

Replace main computer board.

37016: Main computer error.....Chapter 2

Replace main computer board.

37017: Main computer error.....Chapter 2

Replace main computer board.

37018: Main computer error.....Chapter 2

Replace main computer board.

37019: Main computer error.....Chapter 2

Replace main computer board.

Error Messages

Hardware Error Messages (Cont)

37020: Main computer error.....Chapter 2

Replace main computer board.

37021: Main computer error.....Chapter 2

Replace main computer board.

37022: Main computer error.....Chapter 2

Replace main computer board.

37023: Main computer error.....Chapter 2

Replace main computer board.

37024: Main computer error.....Chapter 2

Replace main computer board.

37025: Main computer error.....Chapter 2

Replace main computer board.

37026: Main computer error.....Chapter 2

Replace main computer board.

37027: Main computer error.....Chapter 2

Replace main computer board.

37028: Main computer error.....Chapter 2

Replace main computer board.

37029: Main computer error.....Chapter 2

Replace main computer board.

37030: Main computer error.....Chapter 2

Replace main computer board.

37031: Main computer error.....Chapter 2

Replace main computer board.

Hardware Error Messages (Cont)

37032: Main computer error.....Chapter 2

Replace main computer board.

37033: Main computer error.....Chapter 2

Replace main computer board.

37034: Main computer error.....Chapter 2

Replace main computer board.

37035: Main computer error.....Chapter 2

Replace main computer board.

37036: Main computer error.....Chapter 2

Replace main computer board.

37037: Main computer error.....Chapter 2

Replace main computer board.

37038: Main computer error.....Chapter 2

Replace main computer board.

37039: Main computer error.....Chapter 2

Replace main computer board.

37040: Main computer error.....Chapter 2

Replace main computer board.

37041: Main computer error.....Chapter 2

Replace main computer board.

37042: Main computer error.....Chapter 2

Replace main computer board.

37043: Main computer error.....Chapter 2

Replace main computer board.

Error Messages

Hardware Error Messages (Cont)

37044: Main computer error.....Chapter 2

Replace main computer board.

37045: Main computer error.....Chapter 2

Replace main computer board.

37046: Main computer error.....Chapter 2

Replace main computer board.

37047: Main computer error.....Chapter 2

Replace main computer board.

37048: Main computer error.....Chapter 2

Replace main computer board.

38001: Battery backup lost.....Chapter 2 & 9

Battery backup on serial measurement board %.f power down or restart.

38010: Serial Board not found.....Chapter 2 & 9

Serial measurement board %.f not found.

38011: Data Transmission Error.....Chapter 2 & 9

Failure in transmission of data to/from serial measurement board %.f.

38012: Serial Offset X Error.....Chapter 9

Offset error in X signal on serial measurement board %.f.

38013: Serial Offset Y Error.....Chapter 9

Offset error in Y signal on serial measurement board %.f.

38014: Serial Linearity Error.....Chapter 9

Linearity error in X-Y signal difference on serial measurement board %.f.

- System may still operate with warning
- System will not function with error

Hardware Error Messages (Cont)

- 38015: Serial Linear X Error.....Chapter 9**
Linearity error in X signal on serial measurement board %.f.
- 38016: Serial Linear Y Error.....Chapter 9**
Linearity error in Y signal on serial measurement board %.f.
- 38017: Parallel Comm Error.....Chapter 9**
Communications error to axes board.
- 38018: Parallel Offset AD X.....Chapter 9**
X signal offset exceeds tolerance on axes board.
- 38019: Parallel Offset AD Y.....Chapter 9**
Y signal offset exceeds tolerance on axes board.
- 38020: Parallel Offset DA Error.....Chapter 9**
Offset exceeds tolerance error D/A converter on channel %.f on axes board.
- 38021: Parallel Linearity DA-AD.....Chapter 9**
Linearity error in D/A and A/D converter on channel %.f on axes board.
- 38022: Configuration Error.....Chapter 9**
Error in configuration of measurement system on channel %.f.
- 39001: Drive System Error.....Chapter 9**
DC-link is not connected.
- 39002: Drive System Error.....Chapter 9**
DC-link Power-up status wrong.
- 39003: Drive System Error.....Chapter 9**
DC-link output voltage too high.
- 39004: Drive System Error.....Chapter 9**
DC-link voltage not valid.

Error Messages

Hardware Error Messages (Cont)

39005: Drive System Error.....Chapter 9

DC-link temperature too high.

39006: Drive System Error.....Chapter 9

Shunt temperature too high.

39007: Drive System Error.....Chapter 9

+/- 15V out of limit.

39008: Drive System Error.....Chapter 9

Low current fault on drive unit %.f.

39009: Drive System Error.....Chapter 9

Current too high on drive unit %.f.

39010: Drive System Error.....Chapter 9

Temperature too high on drive unit %.f.

A3.4 Programming Error Messages

These are program errors that can occur during the programming of, or during program execution of the robot. The program errors have the following error codes : 40000 to 49999.

40001: Argument error.....User's Guide

More than one occurrence of same optional parameter is present in the instruction.

40002: Argument error.....User's Guide

Excluding arguments must have conditional value.

Arguments may not be specified for more than one parameter from a list of parameters that exclude each other unless all values are conditional argument values.

40003: Argument error.....User's Guide

Expecting required argument.

40004: Argument error.....User's Guide

Missing optional argument value

Only switch parameters maybe specified by name only. Optionaparameters of other types must be assigned a value. Add a value.

40005: Argument error.....User's Guide

Optional argument at the wrong place in argument list.

40006: Argument error.....User's Guide

Reference to optional parameter in required argument.

An argument corresponding to an optional parameter must be specified with a leading character. Change the required argument into an optional.

40007: Argument error.....User's Guide

Reference to required parameter in conditional argument value

A conditional value for an optional parameter must refer as an optional parameter in the calling routine.

40008: Argument error.....User's Guide

Reference to required parameter in optional argument.

An argument corresponding to a required parameter must not be specified with the leading character.

Error Messages

Programming Error Messages (Cont)

40009: Argument error.....User's Guide

Named required argument at wrong place in argument list.

40010: Argument error.....User's Guide

Switch argument to another value.

An argument corresponding to a switch parameter may not be assigned a value.

40011: Argument error.....User's Guide

Too few arguments in routine call.

A routine call must supply values for all required parameters of the routine being called.

40012: Argument error.....User's Guide

Too many arguments in routine call.

Remove arguments so that no arguments are supplied in excess to those defined by the parameter list of the called routine.

40013: Data declaration error.....User's Guide

Array dimensions must be positive. Change the dimension expression to a positive number.

40014: Data declaration error.....User's Guide

Too many dimensions in array definition.

An array may have at most 3 dimensions.

40015: Type error.....User's Guide

Indexed data is not of array type.

Only data that have been declared to be arrays may be indexed.

40016: Type error.....User's Guide

Data is not of record type.

Components are only available for data of record type. Check the type and name of the referenced data.

40017: Data declaration error.....User's Guide

Expression is not a constant expression.

Expressions contained within data declarations must be constant expressions. Make sure the expression does not contain any variable or persistent reference, or function call.

Programming Error Messages (Cont)

40018: Instruction error.....User's Guide

RETURN from function must have an expression.
A RETURN instruction within a function must specify a function value to be returned. Add a value expression.

40019: Type error.....User's Guide

Illegal combination of operand types for ,operator
The allowed type combinations for the two operands of the ,operator are num,num ,num ,pos. pos ,num. pos * pos an orient * orient. Check the types of the operands.

40020: Instruction error.....User's Guide

Cannot transfer control into another instruction list
Make sure that the label is located in the same instruction list as the GOTO instruction, at the same or an outer level. It is not possible to jump into a program flow instruction, such as a for or while loop.

40021: Type error.....User's Guide

Illegal type for left operand of binary + or - operator.
The allowed types for the operands of the + operator are num, pos and string, for the - operator num and pos. Check the type of the operand.

40022: Type error.....User's Guide

Illegal type for operand of unary + or - operator.
The allowed types for the operands of the + and - operators are num and pos. Check the type of the operand.

40023: Type error.....User's Guide

Illegal type for right operand of binary + or - operator.
The allowed types for the operands of the + operator are num , pos and string, for the - operator are num and pos. Check the type of the operand.

40024: Type error.....User's Guide

Illegal type for left operand of / , DIV or MOD operator'
The only allowed type for the operands of the / , DIV and MOD operators is num. Check the type of the operand.

40025: Type error.....User's Guide

Illegal type for right operand of / , DIV or MOD operator.
The only allowed type for the operands of the / , DIV and MOD operators is num. Check the type of the operand.

Error Messages

Programming Error Messages (Cont)

40026: Type errorUser's Guide

Illegal type for left operand of < .

The only allowed type for the operands is num. Check the type of the operand.

40027: Type errorUser's Guide

Illegal type for right operand of < .

The only allowed type for the operands is num. Check the type of the operand.'

40028: Type errorUser's Guide

Illegal type for left operand of * operator

The allowed types for the operands of the * operator are num, pos and orient. Check the type of the operand.

40029: Type errorUser's Guide

Illegal type for right operand of * operator

The allowed types for the operands of the * operator are num, pos and orient. Check the type of the operand.

40030: Type errorUser's Guide

Illegal type for operand of NOT operator

The only allowed type for the operand of the NOT operator is bool. Check the type of the operand.

40031: Type errorUser's Guide

Illegal type for left operand of OR , XOR or AND operator.

The only allowed type for the operands of the OR , XOR, and "AND" operator is bool. Check the type of the operand.

40032: Type errorUser's Guide

Illegal type for right operand of OR, XOR or AND operator.

The only allowed type for the operands of the OR , XOR, and "AND" operator is bool. Check the type of the operand.

40033: Type errorUser's Guide

Incorrect number of indices in index list

Make sure that the number of indices in the index list is the same as the number of dimensions of the indexed data array.

Programming Error Messages (Cont)

40034: Data declaration error.....User's Guide

LOCAL illegal in routine constant declaration
Only program data declarations may have the LOCAL attribute. Remove the LOCAL attribute or move the declaration outside of the routine.

40035: Data declaration error.....User's Guide

LOCAL illegal in routine variable declaration
Only program data declarations may have the LOCAL attribute. Remove the LOCAL attribute or move the declaration outside of the routine.

40036: Name error.....User's Guide

Constant name ambiguous
Routine data must have names that are unique within the routine. Program data must have names that are unique within the module. Rename the data or change the conflicting name.

40037: Name error.....User's Guide

Global constant name ambiguous
Global data must have names that are unique among all the global data, global routines and modules in the entire task program. Rename the data or change the conflicting name.

40038: Name error.....User's Guide

Global persistent name ambiguous
Global data must have names that are unique among all the global data, global routines and modules in the entire task program. Rename the data or change the conflicting name.

40039: Name error.....User's Guide

Global routine name ambiguous
Global routines must have names that are unique among all the global data, global routines and modules in the entire task program. Rename the routine or change the conflicting name.

40040: Name error.....User's Guide

Global variable name ambiguous.
Global data must have names that are unique among all the global data, global routines and modules in the entire task program. Rename the data or change the conflicting name.

Error Messages

Programming Error Messages (Cont)

40041: Name errorUser's Guide

Label name ambiguous.

Labels must have names that are unique within the routine. Rename the label or change the conflicting name.

40042: Name errorUser's Guide

Module name ambiguous.

Modules must have names that are unique among all the global data, global routines and modules in the entire task program. Rename the module or change the conflicting name.

40043: Name errorUser's Guide

Parameter name ambiguous.

Parameters must have names that are unique within the routine. Rename the parameter or change the conflicting name.

40044: Name errorUser's Guide

Persistent name ambiguous.

Program data must have names that are unique within the module. Rename the data or change the conflicting name.

40045: Name errorUser's Guide

Routine name ambiguous.

Routines must have names that are unique within the module. Rename the routine or change the conflicting name.

40046: Name errorUser's Guide

Persistent name already in sdb.

No two persistent data in the same task program, including predefined Persistents, may share the same name. Rename one of the Persistents.

40047: Name errorUser's Guide

Variable name ambiguous.

Routine data must have names that are unique within the routine. Program data must have names that are unique within the module. Rename the data or change the conflicting name.

40048: Type errorUser's Guide

Operand types for binary + or - operator not equal.

The two operands of the + and - operators must have equal type.

Check the operand types.

Programming Error Messages (Cont)

40049: Type error not equal.....User's Guide

Operators must have equal type. Check the operand types.

40050: Instruction error.....User's Guide

RETURN with expression only allowed in function.
In a procedure or trap the RETURN instruction must not specify a return value expression.
Remove the expression.

40051: Instruction error.....User's Guide

RAISE in error handler must not have an expression.
A RAISE instruction within an error handler can only be used to propagate the current error, and may therefore not specify an error number. Remove the error number expression.

40052: Type error.....User's Guide

Different dimension of array type and aggregate.
Make sure that the number of expressions in the aggregate is the same as the dimension of the data array.

40053: Type error.....User's Guide

Assignment target must have value or semi-value type.
The type, of the data to be assigned a value, must be a value or semi-value type. Data of non-value types may only be Set by special type specific predefined instructions or functions.

40054: Type error.....User's Guide

Operator not value or semi-value type.
Applied to expressions of value or semi-value type. If comparisons are to be made, special type specific predefined functions are needed.

40055: Type error.....User's Guide

Operator not value or semi-value type.
Applied to expressions of value or semi-value type. If comparisons are to be made, special type specific predefined functions are needed.

40056: Type error.....User's Guide

TEST expression not of value or semi-value type.
The TEST instruction may only be applied to an expression of value or semi-value type.
If comparisons are to be made, special type specific predefined functions are needed.

Error Messages

Programming Error Messages (Cont)

40057: Parameter error.....User's Guide

PERS mode parameter cannot be dimensioned.

It is not possible to declare arrays of persistent data. Remove the array dimension specification, or change the mode of the parameter.

40058: Data declaration error.....User's Guide

Place holder for value expression not allowed in definition of named constant.

Complete the data declaration or change the data name to a place holder.

40059: Data declaration error.....User's Guide

Place holder for array dimension not allowed in definition of named constant or variable.

Complete the data declaration or change the data name to a place holder.

40060: Routine declaration error.....User's Guide

Place holder for parameter array dimensions not allowed in definition of named routine

Complete the parameter declaration or change the routine name to a place holder.

40061: Name error.....User's Guide

Place holder for parameter name not allowed in definition of named routine.

Complete the routine declaration or change the routine name to a place holder.

40062: Data declaration error.....User's Guide

Place holder for initial value expression not allowed in definition of named persistent.

Complete the data declaration or change the data name to a place holder.

40063: Routine declaration error.....User's Guide

Place holder for parameter not allowed in definition of named routine.

Complete the parameter declaration, remove the place holder or change the routine name to a place holder.

40064: Reference error.....User's Guide

Place holder for type not allowed in definition of named data or routine.

Complete the data or routine declaration or change the data or routine name to a place holder.

4006S: Data declaration error.....User's Guide

Place holder for initial value expression not allowed in definition of named variable.

Complete the data declaration or change the data name to a place holder.

Programming Error Messages (Cont)

40066: Type errorUser's Guide

Too few components in record aggregate.

Make sure that the number of expressions in the aggregate is the same as the number of components in the record type.

40067: Type errorUser's Guide

Too few components in record aggregate.

Make sure that the number of expressions in the aggregate is the same as the number of components in the record type.

40068: Reference errorUser's Guide

Data reference is ambiguous

At least one other object sharing the same name as the referred data is visible from this program position. Make sure that all object names fulfill the naming rules regarding uniqueness.

40069: Reference errorUser's Guide

Function reference is ambiguous.

At least one other object sharing the same name as the referred function is visible from this program position. Make sure that all object names fulfill the naming rules regarding uniqueness.

40070: Reference errorUser's Guide

Label reference is ambiguous.

At least one other object sharing the same name as the referred label is visible from this program position. Make sure that all object names fulfill the naming rules regarding uniqueness.

40071: Reference errorUser's Guide

Procedure reference is ambiguous.

At least one other object sharing the same name as the referred procedure is visible from this program position. Make sure that all object names fulfill the naming rules regarding uniqueness.

40072: Reference errorUser's Guide

Trap reference is ambiguous.

At least one other object sharing the same name as the referred trap is visible from this program position. Make sure that all object names fulfill the naming rules regarding uniqueness.

Error Messages

Programming Error Messages (Cont)

40073: Reference error.....User's Guide

Not entire data reference.

The specified name identifies an object other than data. Check if the desired data is hidden by some other object with the same name.

40074: Reference error.....User's Guide

Not function reference

The specified name identifies an object other than a function. Check if the desired function is hidden by some other object with the same name.

40075: Reference error.....User's Guide

Not label reference.

The specified name identifies an object other than a label. Check if the desired label is hidden by some other object with the same name.

40076: Reference error.....User's Guide

Not optional parameter reference in conditional argument value

The specified name identifies an object other than an optional parameter. Change the name to refer to an optional parameter.

40077: Reference error.....User's Guide

Not optional parameter reference.

The specified name identifies an object other than an optional parameter. Change the name to refer to an optional parameter.

40078: Reference error.....User's Guide

Not procedure reference.

The specified name identifies an object other than a procedure. Check if the desired procedure is hidden by some other object with the same name.

40079: Reference error.....User's Guide

Not required parameter reference

The specified name identifies an object other than a required parameter. Change the name to refer to a required parameter.

40080: Reference error.....User's Guide

Not trap reference.

The specified name identifies an object other than a trap. Check if the desired trap is hidden by some other object with the same name.

Programming Error Messages (Cont)

40081: Reference error.....User's Guide

Not type name.

The specified name identifies an object other than a type. Check if the desired type is hidden by some other object with the same name.

40082: Type error.....User's Guide

Not value type.

Only variables which lack initial value, and VAR mode parameters maybe of semi-value or non value type.

40083: Reference error.....User's Guide

Reference to unknown entire data.

No data (or other object) with the specified name is visible from this program position.

40084: Reference error.....User's Guide

Reference to unknown function.

No function (or other object) with the specified name is visible from this program position.

40085: Reference error.....User's Guide

Reference to unknown label.

The routine contains no label (or other object) with the specified name.

40086: Reference error.....User's Guide

Reference to unknown optional parameter

The called routine contains no optional parameter (or other object) with the specified name.

40087: Reference error.....User's Guide

Reference to unknown procedure

No procedure (or other object) with the specified name is visible from this program position.

40088: Reference error.....User's Guide

Reference to unknown record component.

The record type contains no record component with the specified name.

40089: Reference error.....User's Guide

Reference to unknown required parameter

The called routine contains no required parameter (or other object) with the specified name.

Error Messages

Programming Error Messages (Cont)

40090: Reference error.....User's Guide

Reference to unknown trap.

No trap (or other object) with the specified name is visible from this program position.

40091: Reference error.....User's Guide

Unknown type name.

No data type (or other object) with the specified name is visible from this program position.

40092: Instruction error.....User's Guide

Assignment target is read only.

The data to be assigned a value may not be a constant, read only variable or read only persistent.

40093: Data declaration error.....User's Guide

Persistent declaration not allowed in routine.

Persistents may only be declared at module level. Move the persistent declaration from the routine.

40094: Instruction error.....User's Guide

RAISE without expression only allowed in error handler.

Add an error number expression to the RAISE instruction.

40095: Instruction error.....User's Guide

RETRY only allowed in error handler

The RETRY instruction may only be used in error handlers. Remove it.

40096: Instruction error.....User's Guide

TRYNEXT only allowed in error handler.

The TRYNEXT instruction may only be used in error handlers, remove it.

40097: Parameter error.....User's Guide

Switch parameter must have transfer mode IN.

Remove the parameter transfer mode specified.

If IN transfer mode is not sufficient, change the data type of the parameter.

40098: Parameter error.....User's Guide

Switch parameter cannot be dimensioned.

Remove the array dimension specification, or change the data type of the parameter.

Programming Error Messages (Cont)

40099: Parameter error.....User's Guide

Switch Only allowed for optional parameter
Change the parameter into an optional parameter, or change the data type of the parameter.
If the object is not a parameter, change the data type.

40100: Type error.....User's Guide

Type mismatch
The expression is not of the expected data type.

40101: Type error.....User's Guide

Type mismatch of aggregate
The aggregate does not match the expected data type.

40102: Data declaration error.....User's Guide

Cannot determine array dimensions (circular constant references?)
Check that any referred constants are correctly defined. If so, the program is too complex.
Try to rewrite the declarations.

40103: Data declaration error.....User's Guide

Cannot determine type of constant value (circular constant references?)
Check that any referred constants are correctly defined. If so, the program is too complex.
Try to rewrite the declarations.

40104: Data declaration error.....User's Guide

Cannot evaluate constant value expression (circular constant references?)
Check that any referred constants are correctly defined. If so, the program is too complex.
Try to rewrite the declarations.

40105: Data declaration error.....User's Guide

Cannot determine type of variable value (circular constant references?)
Check that any referred constants are correctly defined. If so, the program is too complex.
Try to rewrite the declarations.

40106: Type error.....User's Guide

Unknown aggregate type
An aggregate may not be used in this position since there is no expected data type.
Declare data with the desired data type and aggregate value. Use the name of the data instead of the aggregate.

Error Messages

Programming Error Messages (Cont)

40107: Parameter error.....User's Guide

INOUT mode parameter cannot be dimensioned
Remove the array dimension specification or change the parameter mode to VAR or IN.

40121: Argument error.....User's Guide

Argument for PERS parameter is not entire persistent reference or is read only.
Make sure the argument expression is just an entire persistent or entire persistent parameter reference. The persistent may not be read only.

40122: Argument error.....User's Guide

Argument for REF parameter is not data reference.
Make sure the argument expression is just a data or parameter reference. If the data or parameter is persistent, it must be entire.

40123: Argument error.....User's Guide

Argument for VAR parameter is not variable reference or is read only.
Make sure the argument expression is just a variable or variable parameter reference.
The variable may not be read only.

40124: Argument error.....User's Guide

Argument for INOUT parameter is not variable or entire persistent reference or is read only.
Make sure the argument expression is just a variable, entire persistent, variable parameter or entire persistent parameter reference. The variable or persistent may not be read only.

40125: Value error.....User's Guide

Integer value too larger.
The value of the expression must be an integer value. The current value is outside the integer range.

40126: Value error.....User's Guide

Not integer value.
The value of the expression must be an exact integer value. The current value has a fraction part.

40141: Value error.....User's Guide

Division by zero.
Cannot divide by 0. Rewrite the program so that the divide operation is not executed when the divisor is 0.

Programming Error Messages (Cont)

40142: Limit errorUser's Guide

Exceeded maximum number of allowed RETRYs
The error correction performed before the RETRY instruction is executed, is probably not enough to cure the error. Check the error handler.

40143: Instruction errorUser's Guide

Attempt to execute place holder.
Remove the place holder or the instruction containing it, or make the instruction complete.
Then continue execution.

40144: Limit errorUser's Guide

Execution stack overflow
The program is too complex to execute.
Probably the program contains recursive routines.

40145: Execution errorUser's Guide

Function does not return any value.
The end of the function has been reached without a RETURN instruction being executed.
Add a RETURN instruction specifying a function return value.

40146: Value errorUser's Guide

Negative operand not allowed.
The MOD operator only allows non negative operands. Change the program to make sure that the operator is not applied to negative values.

40147: Type errorUser's Guide

Conformant array dimension incompatible.
The array is not of the expected size.
Array assignment may only be performed on arrays of identical size.

40148: Reference errorUser's Guide

Optional parameter not present.
The value of a non present optional parameter may not be refereed. Use the defined function PRESENT the check the presence of the parameter before using its value.

40149: Value errorUser's Guide

Array index out of bounds.
The array index value violates the declared size of the array.

Error Messages

Programming Error Messages (Cont)

40150: Limit errorUser's Guide

Runtime stack overflow.
The program is too complex to execute.
Probably the program contains recursive routines.

40151: Value errorUser's Guide

String too long.
Concatenated string value exceeds the maximum allowed length. Rewrite the program to use strings of lesser length.

40152: limit errorUser's Guide

Cannot wait while waiting.
The argument expression is too complex.

40153: Execution errorUser's Guide

Fatal runtime error.
A fatal runtime error has occurred.

40154: Argument errorUser's Guide

Argument is not an entire persistent.
Can not use a part component of a persistent as an argument for an INOUT or REF parameter

40155: Execution errorUser's Guide

Unhanded non-fatal runtime error in task %.f. See earlier warning %.f
A non-fatal runtime error has occurred but was not handed by any ERROR clause. See previous message for the actual cause.

40156: Argument errorUser's Guide

Duplicated present conditional argument.
More than one present conditional argument for the same parameter

40157: Value errorUser's Guide

Illegal orientation value.
Attempt to use illegal orientation (quaternion) value.

40158: Limit errorUser's Guide

No more interrupt number available.
There is a limited number of interrupt numbers available. Rewrite the program to use fewer interrupt numbers. This message may also occur as a consequence of a System error.

Programming Error Messages (Cont)

40159: Value error.....User's Guide

Illegal error number in RAISE.
Only error numbers in the range 1-99 is allowed in the RAISE instruction.

40160: Execution error.....User's Guide

Unhanded non-fatal runtime error in task %.f.
A non-fatal runtime error has occurred but was not handled by any ERROR clause. See previous message for the actual cause.

40171: Value error.....User's Guide

Array dimension out of range.
The value of the DirNo parameter of the Dim function: must be in the range.

40172: Value error.....User's Guide

Type error data is not an array.
The ArrPar parameter of the Dim function must be an array.

40173: Value error.....User's Guide

Unknown interrupt number.
Check that the specified interrupt variable has been initialized by CONNECT, and that the interrupt has been defined using the IsignalDI or other interrupt definition instruction.

40201: Name error.....User's Guide

Duplicate name in sdb.
No two persistent data in the same task program, including installed Persistents, may share the same name. Rename one of the Persistents.

40202: Name error.....User's Guide

Ambiguous symbol name.
Installed objects must have names that are unique. Rename the object or change the conflicting name.

40203: Name error.....User's Guide

Error when creating sdb entry.
An error occurred when the persistent was to be inserted into the shared database. Probably the database is full.

40204: Type definition error.....User's Guide

Alias of alias not allowed.
Is not possible to define an alias type equal to another alias type.
Instead, define two alias types equal to the same atomic or record type.

Error Messages

Programming Error Messages (Cont)

40205: Symbol definition error dimensioned..... User's Guide

Remove the dimension specification.

40206: Symbol definition error

Use another type.

40207: Parameter error.....User's Guide

alt must not be set for first optional parameter in alternatives list.

Make sure that only the second and following in each list of excluding optional parameters are marked as alternatives.

40208: Parameter error.....User's Guide

PERS mode parameter cannot be dimensioned.

It is not possible to declare arrays of persistent data. Remove the array dimension specification, or change the mode of the parameter.

40209: Parameter error.....User's Guide

REF mode parameter cannot be dimensioned.

Remove the array dimension specification, or change the mode of the parameter.

40210: Parameter error.....User's Guide

switch parameter cannot be dimensioned.

40211: Parameter error.....User's Guide

switch parameter must have transfer mode IN.

40212: Symbol definition error.....User's Guide

Switch only allowed for optional parameter.

Change the parameter into an optional parameter, or change the data type of the parameter.

If the object is not a parameter, change the data type.

40213: Type definition error.....User's Guide

Value type class must be one of

PGM_SYMVALTYP_VAL, SEMIVAL_NONVAL or_NONE.

40214: Parameter error.....User's Guide

INOUT mode parameter cannot be dimensioned.

Remove the array dimension specification, or change the parameter

mode to VAR or IN.

Programming Error Messages (Cont)

40215: Data declaration error.....User's Guide

Too many array dimensions.
An array may have at most 3 dimensions.

40216: Name error.....User's Guide

Symbol name must be an RAPID identifier excluding reserved words.
The names of installed objects, including parameters and components, must be legal RAPID identifiers not equal to any of the reserved words of the RAPID language. Change the name.

40217: Symbol definition error.....User's Guide

Missing C function.
A C-function that executes the Real function being defined, must be specified.

40218: Symbol definition error.....User's Guide

Missing value initialization function.
A value initialization function must be specified.

40219: Reference error.....User's Guide

Not a data type name.
The specified name identifies an object other than a type.

40220: Reference error.....User's Guide

Not a value data type.
Only record components, alias types, variables and VAR mode parameters may be of semi-value or non_value type.

40221: Symbol definition error.....User's Guide

Missing value conversion function.
A value conversion function must be specified for a semi. value type.

40222: Type definition error.....User's Guide

Private type can only be semi-value or non_value type.
Change the value type class.

40223: Type definition error.....User's Guide

Private type size must be multiple of 4.
All RAPID types must have a size that is a multiple of four. Change the specified type size.

Error Messages

Programming Error Messages (Cont)

40224: Reference error.....User's Guide

Unknown data type name.
There is no data type (or other object) with the specified name.

40225: Parameter error.....User's Guide

Unknown parameter transfer mode.
The specified parameter transfer mode is not one of IN, VAR, PERS, INOUT or REF. Use corresponding PGM_SYMPARMOD_x.

40226: Symbol definition error.....User's Guide

No such symbol definition type.
The symbol definition type tag does not specify one of the allowed symbol types (PGM_SYMDEF_x)

40501: TimeoutUser's Guide

40502: Digital input break.....User's Guide

40503: Reference error.....User's Guide

Device descriptor is %s.

40504: Parameter error.....User's Guide

40505: File access errors.....User's Guide

40506: System access error &s.....User's Guide

40507: Limit error.....User's Guide

40508: Wrong orientation value in %s..... User's Guide

40509: Search warning %s.....User's Guide

Before performing next search make sure the TCP is moved back to the start position of the search path.
If no repositioning is done before restart, movement that can cause damage might occur.

40510: Security warning.....User's Guide

The move instruction can not restart due to security problem.
Try to move the PP.

Programming Error Messages (Cont)

40511: Parameter error.....User's Guide

The parameter %s in %s is specified as a negative value
The parameter must be set positive.

40512: Missing external axis value.....User's Guide

Some active external axis have incorrect or no order value.
Reprogram the position.

40513: Mechanical unit error.....User's Guide

Not possible to activate or deactivate mechanical unit.

40514: Execution error.....User's Guide

Too far from path to perform StartMove of the interrupted movement.
Position the robot to the interrupted position in the program.

40600: Argument error.....User's Guide

No WObj specified for movement with stationary TCP.
Add argument WObj for actual work object.
If not movement with stationary TCP, change argument Tool to
robot holds the tool.

40601: Argument error.....User's Guide

Undefined if robot holds the tool or the work object.
Check if miss match between argument Tool and argument WObj for data component
robhold.

40602: Argument error.....User's Guide

Argument %s has at least one data component with negative value.
Set all data components in argument %s to positive values.

40603: Argument error.....User's Guide

Argument %s has not allowed negative value.
Set argument %s to positive.

40604: Argument error.....User's Guide

Argument Tool has undefined load of the tool!
Define the actual load of the tool before use of the tool for jogging or program movement.

Error Messages

Programming Error Messages (Cont)

40605: Argument error.....User's Guide

Argument Tool has negative load of the tool.
Define the correct load of the tool before use of the tool for jogging or program movement.

40606: Argument error.....User's Guide

Argument Tool has at least one inertia data component with negative value.
Define all inertia data components (ix, iy or iz) to actual positive values.

40607: Execution error.....User's Guide

Not allowed to change run mode from forward to backward or vice versa during running a circular movement.

40608: Argument error.....User's Guide

Orientation definition error in %5.
All used orientations must be normalized i.e. the sum of the quaternion elements squares must equal 1.

40609: Argument error.....User's Guide

Argument WObj specify an mechanical unit with too long name.
Use max. 16 character to specify the name of an mechanical coordinated unit.

40610: Argument error.....User's Guide

Argument WObj specify a mechanical unit name, which is not activated or unknown in the system.
The mechanical unit name defined in WObj must correspond to the name earlier defined in the system parameters and must be activated.

40611: Execution error.....User's Guide

Not allowed to step backwards with actual instruction.
Not allowed to step backwards in a circular movement, if the endpoint of the circular movement is defined with another tool and/or work object.

40612: Argument error.....User's Guide

No argument programmed for the name of the output signal.
Possible to set one position fix IO such as digital, group of Digital's or analog output signal during the robot movement.

40613: Argument error.....User's Guide

Option argument %s can only be combined with output signal argument %s.

Programming Error Messages (Cont)

40614: Argument error.....User's Guide

Argument %s is not 0 or 1.
Digital output signals can only be set to 0 or 1.

40615: Argument error.....User's Guide

Argument %s is not an integer value.
Digital group of output signals can only have an integer value.

40616: Argument error.....User's Guide

Argument %s is outside allowed limits.
Used group of digital output signals can only be set within 0 to %s according configuration in the system parameters.

40617: Argument error.....User's Guide

Argument %s is outside allowed limits.
Used analog output signals can only be set within %s to %s according configuration in the system parameters.

40618: Argument error.....User's Guide

Argument %s contains an illegal interrupt number.
Input interrupt number is illegal because it has not been allocated by the instruction CONNECT.

40619: Argument error.....User's Guide

Argument %s contains an interrupt number, which is already in use for other purpose.
Before reuse of an interrupt variable again in the program, cancel old interrupt generation and interrupt number with instruction Delete.

40620: Argument error.....User's Guide

Argument Interrupt has negative value for ISignalDI.

40621: Argument error.....User's Guide

Argument Interrupt has negative value for ITimer.

40622: Argument error.....User's Guide

The value of argument Time in Itimer is to low for cyclic interrupts.

40623: Argument error.....User's Guide

The value of argument Time in ITimer is to low for single interrupts.

Error Messages

Programming Error Messages (Cont)

40624: Argument error.....User's Guide

The value of argument Time in ITimer is to high.

40625: Argument error.....User's Guide

Argument Interrupt has negative value for IDelete.

40626: Argument error.....User's Guide

Signal interrupt could not be activated.

40627: Argument error.....User's Guide

Intnum for Signal interrupt not possible to use.

40628: Argument error.....User's Guide

Timer interrupt could not be activated.

40629: Argument error.....User's Guide

Intnum for Timer interrupt not possible to use.

40630: Argument error.....User's Guide

Bad intnum for IDelete given.

40631: Instruction error.....User's Guide

Too many move instructions in sequence with concurrent RAPID program execution.

40632: Instruction error.....User's Guide

No move instructions with concurrent RAPID program execution are allowed within the StorePath - RestoPath part of the program.

40633: Reference error.....User's Guide

Trigg parameter no %s reference to undefined trigg data.
Define trigg data by executing instruction TriggIO or TriggInt before TriggL, TriggC or TriggI.

40634: Reference error.....User's Guide

Signal reference in parameter %s contains unknown signal for the robot.
All signals should be defined in the system parameters and should not be defined in the RAPID program.

A3.5 Motion Error Messages

These are motion errors that can occur during the movement of the robot.
The motion errors have the following error codes : 50000 to 59999.

50001: Serious motion error.....Chapter 9

Not possible to proceed motion control. Check: Start up the system again.

50021: Joint position error.....Chapter 9

Actual position of joint %s is too far away from the ordered position. Check: Check trim parameters, external forces or hardware.

50022: Too low DC-link voltage.....Chapter 9

Check: Check voltage from Motor On contactors Replace DC-link.

50023: Stop/Restart error

The stop was made when too many move instructions were queued for execution. Restart is not possible. Check: Check the number of move instructions with concurrency. Move the start point and start a new movement.

50024: Corner path failure

A corner path was executed as a stop point due to a time delay. Check: Check the number of instructions between the move instructions.

50025: Restart too far from path

Check: Move back to path.

50026: Singularity or Zone error

1. Robot too close to singularity.
2. MoveL to MoveJ corner zone error.

Check:

1. Use the joystick to move away from the singularity or run a program in joint coordinates.
2. Use fine point or modify position.

50027: Joint Out of Range

Joint %s is out of working range. Check: Use the joystick to move the joint into its working range.

50028: Jog in wrong direction

Error Messages

Motion Error Messages (Cont)

Joint %s is out of working range. Check: Use the joystick to move the joint in opposite direction.

50029: Robot outside its limits

The robot has reached the configuration limit for the parallelogram transmission. Check: Use the joystick to move the involved joint into the working range again.

50030: Robot outside its limits

Jogging was made in wrong direction when parallelogram was out of working range. Check: Use the joystick to move the joint in opposite direction.

50031: Command not allowed

System parameters cannot be changed in MOTORS ON state. Check: Change to MOTORS OFF.

50032: Calibration command error.....Chapter 10

An attempt was made to calibrate while in MOTORS ON state. Check: Change to MOTORS OFF.

50033: Commutation command error.....Chapter 9

An attempt was made to commutate the motors in MOTORS ON state. Check: Change to MOTORS OFF.

50035: Synchronization error.....Chapter 10

An attempt was made to synchronize in MOTORS ON state. Check: Change to MOTORS OFF.

50036: Correct regain impossible

Correct regain impossible. A stop occurred with too many close points with corner zones. At restart the robot will move to a point farther forward in the program. Check: Reduce the number of close points, increase the distance between them or reduce the speed.

50037: MOTORS ON order ignored.....Chapter 5

MOTORS ON order ignored since the previous stop was not yet acknowledged. Check: Order MOTORS ON again.

50041: The robot is too close to a singularity

Check: During program execution, use SingArea instruction or joint interpolation. During jogging, use axis by axis.

Motion Error Messages (Cont)

50042: System error

Check: Increase the distance between close points and/or decrease speed and/or change acceleration value.

50050: Position outside reach

Position for IRB joint %f is outside working area. Check: Check the work object. Check the joint working range. Move the joint in joint coordinates.

50052: Joint speed error

The speed of joint %s is too high relative the ordered speed. Check:

1. Check the tune parameters, external forces on the joint and hardware
2. Reduce programmed speed

50053: Revolution counter error.....Chapter 9

Too big difference between the counter in the serial measurement board and the expected value in the robot computer for joint %s. Check: Update the revolution counter. Replace serial measurement board.

50055: Joint load error.....Chapter 9

Actual torque on joint %s is higher than ordered. Check: May be caused by incorrect load data, hardware error or to high acceleration.

1. Check load data
2. Check hardware
3. Reduce acceleration

50056: Joint collision error.....Chapter 9

Actual torque on joint %s is higher than ordered while at low or zero speed. Check: May be caused by jam error (the arm has got stuck) or hardware error.

50057: Joint sync. error.....Chapter 9

The position of joint %s after power failure is too far away from the position before the power failure. Check: Make a new update of the revolution counter.

50058: Tool coord. sys. error

The z-direction of the tool coordinate system is almost parallel with the path direction. Check: Change the tool coordinate system to achieve at least 3 degrees deviation between z-direction and path direction.

Error Messages

Motion Error Messages (Cont)

50059: Frame error

The definition of robot fixed tool is not correct. Check: Check the tool and object data.

50060: Frame error

The definition of robot fixed tool is not correct. Check: Check the tool and object data.

50061: Frame error

The definition of robot fixed tool is not correct. Check: Check the tool and object data.

50062: Circle programming error

Start and end positions for the circle are too close.

50063: Circle programming error

The circle position is too close to the start or end position of the circle.

50065: Kinematics error

The destination of the movement is outside the reach of the robot or too close to a singularity. Check: Change the destination position.

50066: Robot not active

Attempt to coordinate motion or calculate position of deactivated robot %s. Check: Activate robot via the Motion Unit key, then Jogging window, or program. Check work object and program.

50067: Unit not active

Attempt to coordinate motion or calculate position of deactivated single unit %s. Check: Activate unit via Motion Unit key, then Jogging window, or program. Check work object and program.

50076: Orientation def. error

Orientation is incorrectly defined. Check: Make an accurate normalization of the quaternion elements.

50078: Too many close positions

Too many consecutive closely spaced positions. Check: Increase the distance between consecutive close positions.

Motion Error Messages (Cont)

50079: Wrist weaving not possible

Check: Use smaller weaving amplitude or a larger TCP.

50080: Position not compatible

Position cannot be reached with the given robot configuration. Check: Modify the robot position in the program.

50082: Deceleration limit

Calculation of joint deceleration time exceeds internal limits for this motion. Check: Do not proceed without removing the causes of the error. See Check. Check deceleration of external axes. Check noise level on I/O connections. Increase Path resolution, Queue length. Decrease program speed, and/or increase. AccSet parameters (if below 100%).

50083: Speed lowered by system

The speed has been lowered by the system due to dynamic limitations. Check: Decrease speed and/or do not use close positions at high speed and/or increase acceleration (if below 100%).

50085: Too many user frames

For mech_unit %s more than one user frame has been defined. Check: Take away one user frame or define one more mech_unit.

50086: Singularity calc. error

Too close to wrist singularity with respect to numerical resolution for joint 4 of IRB. Check: Change destination position a few increments.

50087: Singularity problems

Too close to wrist singularity with respect to numerical resolution for joint 6 of IRB. Check: Change destination position a few increments.

50088: Restart not possible

It is not possible to restart the path due to a previous error. Check: Move the program start point and start a new movement.

50089: Lower weaving frequency

The weaving period length or period time is too short. Check: Increase weave length or increase period time.

Error Messages

Motion Error Messages (Cont)

50091: Restart no longer possible

Change of unit state made restart of program impossible. Check: Move the program pointer and start a new movement.

50092: Axis computer comm. error

Incorrect response from axis computer. Check: Check motion configuration parameters. Check axis computer hardware.

50093: Load too large

The defined load mass is too large.

50094: ServoTune not possible

Tuning is not implemented for the specified Joint.

50095: Cannot access external joint

Check configuration and activation of external Joints.

50100: Configuration error

There are more configuration or numerical errors in motion domain. Check: Correct previous ones and try again.

50101: Configuration error

'%s'isnotavailablefor' the attribute '%s'intype'%s''instance '%s'.' Check: Use another instance.

50102: Configuration error

'%s'usedbytheattribute'

'%s'intype'%s''instance'

'%s'isnotdefined.'

Check: Define the instance.

50103: Numerical param error

The orientation defined by the attributes.

'%s'intype'%s''instance'

'%s'isnotnormalised.'

Check: Recalculate the orientation.

50104: Configuration error

Only one of '%s'intype'%s''instance' '%s'canbeused.' Check: Use only one.

Motion Error Messages (Cont)

50105: Numerical param error

The numerical test ending with attribute %s'intype'%s" instance %s'failed.' Check: Check the value.

50106: Numerical param error

The numerical comparison %s'intype'%s" instance %s'failed.' Check: Check the values.

50107: Configuration error

The attribute %s'intype' %s'instance'%s" must have the same number as the instance. Check: Change the attribute.

50130: Synchronization failed for joint %s

50131: Calibration failed for joint %s

50132: Commutation failed for joint %s

50133: Test signal error

No test signals are available for the master robot.

50134: Corr. vector warning

Sensor correction vector calculations failed due to previous error.

50135: SoftAct not possible

Soft servo is not possible to activate.

50136: SoftAct not possible

Soft servo is not possible to modify during ramping.

50137: Fine point inserted

Corner zone is changed to fine point. Too many consecutive Move instructions without fine point.

50138: Arm check point outside

The robot has reached the limit for arm check point. Check: Use the joystick to move the involved joint into the working range again.

Error Messages

Motion Error Messages (Cont)

50139: Arm check point outside

Jogging was made in wrong direction when arm check point was out of working range.
Check: Use the joystick to move the joint in opposite direction.

50140: Payload too large

Heavy payload caused static torque limit to be exceeded on joint %s. Check: Check and reduce payload for arm and/or wrist. Reduce joint working range to decrease static torque due to gravity.

50141: Speed, Zone or Jog error

1. Robot too close to singularity
2. MoveL to MoveJ corner zone error
3. Jogging error
4. High speed error

Check:

1. Move away from the singularity or run the program in joint coordinates
2. Use fine point or modify position
3. Try again
4. Reduce the programmed speed

A3.6 Operator Error Messages

These are operator errors that can occur during the programming of the robot.
The operator errors have the following error codes : 60000 to 69999.

60001: %s missing

Tool %s is not used in current program. Maybe because it has been deleted or it is not defined. Check: Change to another tool using the Jogging window.

60002: %s missing

Wobj %s is not used in current program. Maybe because it has been deleted or it is not defined. Check: Change to another workobject using the Jogging window.

60003: Directory not created!

The directory %s cannot be created. Probably, because directory already exists or the disk is write-protected. Check: Check if directory exists or if disk is write-protected. Check also if space on disk is enough.

60004: Robot Hold confusion!

The used tool and the used work object cannot both, in the same time, be hold by robot or be stationary. Check: Check the robhold component of the used tool and work object.

60005: %s missing!

The workobject %s contains a coordinated mechanical unit which cannot be found. Check: Check the mechanical unit component of the workobject.

60006: %s Userframe!

The workobject %s contains a coordinated mechanical unit which has no defined userframe. Check: Check the mechanical unit component of the workobject.

60007: Jogging not permitted!

Jogging cannot be done in this mode. Check: Release the joystick and enabling device and repeat. Check also active mechanical unit.

60008: Tool mass undefined!

Jogging cannot be done if the used tool has an undefined mass. Check: Enter a value for the mass, into the tooldata for the used tool.

Error Messages

Operator Error Messages (Cont)

60009: Unsynchronized robot!

The robot or external axis are unsynchronized. Check: Synchronize robot or external axis.

60010: Orientation error!

Orientation in %s is unnormalized. Check: Check orientation value.

60011: Parameter faults!

Loading of parameters in %s cannot be fulfilled. For reason, see %s. Check: Copy the file %s to a floppy and examine reasons using an ordinary text editor.

60012: No Parameters loaded!

There are no parameters in %s. Check: Check the file %s using an ordinary text editor.

60013: Jogging not permitted!

Jogging of mechanical unit is not possible. Unit is not activated. Check: Activate the mechanical unit.

60014: Disk is full!

No info is saved in Change Log about the parameter change because no space available on disk. Check: Try to delete files or reorganize your disk.

A3.7 I/O & Communication Error Messages

These are communication errors that can occur during the execution of communication instructions. The communication errors have the following error codes : 70000 to 79999.

71000: Bus name invalid.....Chapter 11

DescriptionReason: Driver %s: has an invalid bus name. Check:
1. Change the busname for the driver

71001: Duplicated address.....Chapter 11

DescriptionReason: Same address for unit %s and %s. Check:
1.Check the address
2.Check the bus

71002: Invalid driver.....Chapter 11

DescriptionReason: Unit %s: has an unspecified driver. Check:
1.Check the drivers against the one specified for the unit

71003: Invalid unit.....Chapter 11

DescriptionReason: The unit specified for the signal %s is not specified in the unit section.
Check:
1.Change the name of the unit
2.Add a new unit to the unit list

71004: Invalid signal length.....Chapter 11

DescriptionReason: The length of the digital signal %s must be 1. Check:
1. Change the length to 1 or remove the statement

71005: Filter time invalid.....Chapter 11

DescriptionReason: Signal %s: The passive filter time should be 0 or %d - %d ms. Check:
1.Change the filter time

71006: Filter time invalid.....Chapter 11

DescriptionReason: Signal %s: The active filter time should be 0 or %d - %d ms. Check:
1. Change the filter time

71007: Logical value out of range.....Chapter 11

DescriptionReason: Signal %s: Logical Max is less or equal than Logical Min. Check:
1. Correct the values to be max greater than min

Error Messages

I/O & Communication Error Messages (Cont)

71008: Phys. value out of range.....Chapter 11

DescriptionReason: Signal %s: Physical Max is less or equal than Physical Min. Check:
1. Correct the values to be max greater than min

71009: Type invalid.....Chapter 11

DescriptionReason: Signal %s: the type of signal is invalid. Check:
1. Change the type

71010: Signal out of range.....Chapter 11

DescriptionReason: Signal %s: the physical signal. Check:
1. Change the physical signal number
2. Change the length

71011: Driver not supported.....Chapter 11

DescriptionReason: The driver %s is not supported. Check:
1. Change the name of the driver

71012: Memory overflow.....Chapter 11

DescriptionReason: Board %s: Too many boards for specified driver type. Check:
1. Change number of boards for the driver at driver configuration.

71013: Wrong type of board.....Chapter 11

DescriptionReason: Wrong type of board connected to address %d. Check:
1. Check the board type at given address

71014: Board missing.....Chapter 11

DescriptionReason: No board connected at given address %d. Check:
1. Connect a board to the slot
2. Change the board address

71015: Digital Input overflow.....Chapter 11

DescriptionReason: Number of digital input channels for board %s is greater than %d.
Check:
1. Reduce the number digital inputs

71016: Digital Output overflow.....Chapter 11

DescriptionReason: Number of digital output channels for board %s is greater than %d.
Check:
1. Reduce the number of digital outputs

I/O & Communication Error Messages (Cont)

71017: No activate signal.....Chapter 11

DescriptionReason: Missing activate signal for cross. Check:
1. One activate signal must be given

71018: Activate signal overflow.....Chapter 11

DescriptionReason: Number of activate signals for cross to high. Check:
1. Only one activate signal must be given

71019: Missing signal definition.....Chapter 11

DescriptionReason: The signal: %s, at cross is not defined. Check:
1. Define the signal name in signal section

71020: No result signal.....Chapter 11

DescriptionReason: Missing result signal. Check:
1. At least one result signal must be given

71021: Duplicate cross signals.....Chapter 11

DescriptionReason: The signal: %s, appears both as FROM and as TO. Check:
1. The same signal can not be given for both FROM and TO

71022: Physical max too high.....Chapter 11

DescriptionReason: Signal: %s. Check:
1. Change value in configuration

71023: Physical min too low.....Chapter 11

DescriptionReason: Signal: %s. The physical min value < %d. Check:
1. Change value in configuration

71024: Physical value too high.....Chapter 11

DescriptionReason: Signal: %s. Value set to Maxvalue. Check:
1. Change physical max value in configuration

71025: Physical value too low.....Chapter 11

DescriptionReason: Signal: %s. Current value = %d < Minvalue = %d. Value set to Minvalue. Check:
1. Change physical min value in configuration

Error Messages

I/O & Communication Error Messages (Cont)

71026: Logical value too high.....Chapter 11

DescriptionReason: Signal: %s. Current value = %d < Maxvalue = %d. Value set to Maxvalue. Check:

1. Change logical max value in configuration

71027: Logical value too low.....Chapter 11

DescriptionReason: Signal: %s. Current value = %d < Minvalue = %d. Value set to Minvalue. Check:

1. Change logical min value in configuration

71028: Config. out of range.....Chapter 11

DescriptionReason: The RIO starting quarter and rack size is out of range for board %s. Check:

1. For starting quarter 0 rack size must be less than 4

71029: Config. out of range.....Chapter 11

DescriptionReason: The RIO starting quarter and rack size is out of range for board %s. Check:

1. For starting quarter 1 rack size must be less than 3

71030: Config. out of range.....Chapter 11

DescriptionReason: The RIO starting quarter and rack size is out of range for board %s. Check:

1. For starting quarter 2 rack size must be less than 2

71031: Config. out of range.....Chapter 11

DescriptionReason: The RIO starting quarter and rack size is out of range for board %s. Check:

1. For starting quarter 3 rack size must be 0

71032: Communication fail.....Chapter 11

DescriptionReason: The RIO board has lost communication with the PLC at board address %d. Check:

1. Check the communication cable to PLC
2. Check if the PLC is switched off

71033: Digital input out of range.....Chapter 11

DescriptionReason: The number of digital inputs is out of range at board address %d max inputs are %d. Check:

1. Change the configuration for the board

I/O & Communication Error Messages (Cont)

71034: Digital output out of range.....Chapter 11

DescriptionReason: The number of digital outputs is out of range at board address %d max outputs are %d. Check:

1. Change the configuration for the board

71035: Starting quarter out of range.....Chapter 11

DescriptionReason: The starting quarter is out of range for board %s. Check:

1. The starting quarter must be within the values 0 to 3
2. Change the config file

71036: Name out of range.....Chapter 11

DescriptionReason: The number of characters in name %s is greater than %d characters. Check:

1. Give a new name that fits within the limits

71037: IO Cross connection fault.....Chapter 11

DescriptionReason: The signal %s appears on both FROM and TO in the same chain. Check:

1. Correct the configuration for the crossconnections there the signal above is connected

71038: IO Cross depth to high.....Chapter 11

DescriptionReason: The Cross connection in the same chain is too deep. First signal name: %s. Check:

1. Make the Cross connection less deep

71039: Max instances out of range.....Chapter 11

DescriptionReason: The max number of instances for driver %s is out of range. Check:

1. Make sure that the number of instances is greater than 0, and not more than number of IO slots

71040: RIO link address out of range.....Chapter 11

DescriptionReason: The RIO link address for board %s is out of range. Check:

1. Make sure that the RIO link address is greater than 0, and less than 64

71041: Analog output overflow.....Chapter 11

DescriptionReason: Number of analog output for board, %s is greater than %d. Check:

1. Reduce the number of analog outputs

71042: Analog inputs overflow.....Chapter 11

DescriptionReason: Number of analog inputs for board, %s is greater than %d. Check:

1. Reduce the number of analog inputs

Error Messages

I/O & Communication Error Messages (Cont)

71043: Signal type error.....Chapter 11

DescriptionReason: The type specified for signal %s cant be connected to specified board. Check:

1. Change to another type
2. Change to another board

71044: Physical signal overflow.....Chapter 11

DescriptionReason: The range of phsig, or length, or phsig and length for signal %s is greater than %d. Check:

1. Change the physical signal number
2. Change the length

71045: Filter specification error.....Chapter 11

DescriptionReason: Signal %s: No filter time can be specified for this type of signal. Check:

1. Set filter time to 0 or remove the statement

71046: Scaling error.....Chapter 11

DescriptionReason: Signal %s: No scaling can be done. Check:

1. Remove the scaling statements

71049: Parameter Invert error.....Chapter 11

DescriptionReason: Signal %s: This type of signal cant be inverted. Check:

1. Only digital signals can be inverted

71050: Signal for cross not digital.....Chapter 11

DescriptionReason: Signal %s: Is not a digital signal. Check:

1. Only digital signals can be cross connected

71051: Link address not octal.....Chapter 11

DescriptionReason: Signal %s: The RIO address is not in octal form. Check:

1. Reenter a new address in octal form

71052: Cross table full.....Chapter 11

DescriptionReason: The cross connection can only contain %d signals. Check:

1. Reduce the number of signals

71053: RIO connection down.....Chapter 11

DescriptionReason: CantaccessRIOboarddueto' communication with PLC is down. Check:

1. Check the communication cable to PLC
2. Check of if the PLC is switched off

APPENDIX B

PARTS LISTS

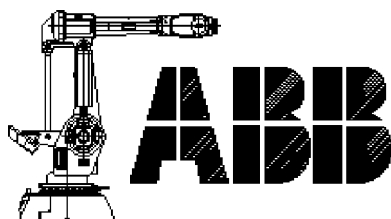

Parts Lists

Table of Contents

B.	PARTS LISTS	B-3
B1.	Control System Parts List.....	B-3
B1.1	Power Supply Side	B-3
B1.2	Operator's Panel	B-3
B1.3	Teach Pendant	B-4
B1.4	Contactor Unit	B-4
B1.5	Computer System	B-4
B1.6	Drive System	B-5
B1.7	Optional Units	B-5
B1.8	Miscellaneous	B-6
B2.	Suggested Spare Parts List	B-7
B2.1	Axis 1	B-7
B2.2	Axis 2 & 3	B-7
B2.3	Lower Arm	B-7
B2.4	Upper Arm	B-8
B2.5	Cables	B-8
B2.6	Control	B-9

NOTES

B. PARTS LISTS

B1. Control System Parts List

B1.1 Power Supply Side

Item	Qty.	Name	Art. No.	Rem
Z1		Power supply filter	3HAB 5425-1	
QS1		Lockable circuit breaker	5324 688-3	
		Automatic fuse	3HAB 2017-2	Option 143/144
		Flange disconnecter	3HAB 2703-1	400-475V
			3HAB 2703-2	400-600V
TM1		Transformer with automatic fuse and 5x20mm fuses		
			3HAB 2947-1	200-400V
			3HAB 2945-1	400-500V
			3HAB 2946-1	475-600V
FS1	1	Automatic fuse	3HAB 5107-1	4-pole
	2	Fuse	5672 817-22	6, 3A slow, 5x20mm
	1	Fuse	5672 817-19	3.15A

B1.2 Operator's Panel

Item	Qty.	Name	Art. No.	Rem
SA1	1	Operating mode selector	3HAA 3003-21	
SA2,3	2	Lamp pushbutton	SK 615 202-CH	
	3	Contact block	SK 616 001-A	
	2	Lamp block	SK 616 003-A	
	2	Glow lamp	5911 069-10	36V 3,5 W, BA 9S
SA4	1	EM stop button	3HAB 5171-1	
	1	Contact block	3HAB 5171-10	
D1		Floppy disk unit	3HAB 2596-1	Contains the floppy
		Floppy disk driver	3HAB 2480-1	disk driver
		Cable	3HAB 2759-1	
PT		Duty time counter	3HAA 3001-7	24V DC

Control System Parts List (Cont)

B1.3 Teach Pendant

Item	Qty.	Name	Art. No.	Rem
		Complete unit	3HAB 5386-1	
		Program board	3HAA 3573-ABA	DSQC 301
		Display	3HAA 3101-BD	
		Membrane keyboard	3HAB 2027-1	
		Joystick unit	3HAA 3001-22	
		3-Mode switch	3HAB 2105-1	
		EM stop, button	3HAB 5171-1	
		Contact block	3HAB 5171-10	
		Connection cable	3HAB 5388-1	10m
		Extension cable	3HAA 3560-LXA	10m
		Shelf for teach pendant	3HAA 3560-GSA	

B1.4 Contactor Unit

Item	Qty.	Name	Art. No.	Rem
KM1,2	2	Contactor	3HAA 3003-19	MOTORS ON
KM3	1	Contactor	3HAB 2425-1	Supervision
KM4	1	Contactor	3HAA 3001-4	Brake
AP60	1	Component unit	3HAB 2989-1	Varistors, diodes

B1.5 Computer System

Item	Qty.	Name	Art. No.	Rem
AP33	1	DSQC 326	3HAB 2242-1	Robot CPU
AP31	1	DSQC 316	3HAB 2219-1	Main CPU
GS1	1	DSQC 258	3HAA 3563-AUA	Power supply
AP41	1	DSQC 256A	3HAB 2211-1	System board
AP80	1	DSQC 302	3HAA 3573-ACA	Rear plane
AP81	1	DSQC 307	3HAA 3573-AJA	Rear plane VME
AP32		DSQC 317	3HAB 2220-1	Memory, 6MB
AP32		DSQC 321	3HAB 2236-1	Memory, 4MB

Control System Parts List (Cont)

B1.6 Drive System

Item	Qty.	Name	Art. No.	Rem
AP1-3	3	DSQC 236 T	YB 560 103-CE	Servo power unit, Axis 1-3
AP4-6	3	DSQC 236 G	YB 560 103-CD	Servo power unit, Axis 4-6
AP7	1	DSQC 236 C or DSQC 236 T	YB 560 103-CC or YB 560 103-CE	Servo power unit, Axis 7
AP9	1	DSQC 314 B	3HAB 2216-1	Rectifier
AP10	1	DSQC 257	3HAA 3563-ATA	Rear Plane
EV1-3	3	Fan	6480 096-5	24V DC

B1.7 Optional Units

Item	Qty.	Name	Art. No.	Rem
AP11-16	6	Digital I/O, DSQC 223 Cable Cable	YB 560 103-BD 3HAB 2003-1 2639 0351-LA	16 in/16 out, 24VDC External connection To connection unit
XT11-16		Connection unit Connection unit, relay	3HAA 3003-33 3HAB 2067-1	Screw Terminals Screw Terminals
AP11	1	Analog I/O, DSQC 209	YB 560 103-AL	3 outputs $\pm 10V$ 1 output $\pm 20mA$ 4 inputs 0- $\pm 10V$
		Cable	3HAB 2004-1	External Connection
		Cable	3HAB 2125-1	To Connection unit
AP11	1	Combi I/O, DSQC 215	3HAB 2214-1	16 in/16 out, 24VDC, 2 out 0-10V
		Cable	3HAB 2005-1	External Connections
		Cable	3HAB 2128-1	To connection unit
XT10,11	2	Connection unit	3HAA 3003-33	Screw terminals
EV4		Cooling device	3HAA 3003-57	
		Dust filter (cool dev.)	7820 004-3	Package with 3
		External operator's panel	3HAB 2140-1	
		External axes board	YB 560 103-BS	DSQC 233

Control System Parts List (Cont)

B1.8 Miscellaneous

Item	Qty.	Name	Art. No.	Rem
	2	Battery	3HAB 2038-1	RWM
SB1,2,3		Micro switch	5397 038-1	For fan, cool device
Z2		Varistor board, DSQC 232	YB 560 103-CF	
XS1,3,4,5		Industrial connector	5217 687-25	Female insert 64-pole
		Cable, measurement	3HAB 2678-1	7m
		Cable, motor	3HAB 2684-1	7m
		Cable, measurement	3HAB 2682-1	7m, metal braid protection
		Cable, motor	3HAB 2688-1	7m, metal braid protection
		Cable, measurement	3HAB 2679-1	15m
		Cable, motor	3HAB 2685-1	15m
		Cable, measurement	3HAB 2683-1	15m, metal braid protection
		Cable, motor	3HAB 2689-1	15m, metal braid protection
		Cable, measurement	3HAB 2680-1	22m
		Cable, motor	3HAB 2686-1	22m
		Cable, measurement	3HAB 2681-1	30m
		Cable, motor	3HAB 2687-1	30m
XT5		Customer cable, signal	3HAA 3560-HJA	7m
XT6		Customer cable, power	3HAA 3560-NNA	7m
		Customer cable, signal	3HAB 3560-NVA	7m, metal braid protection
		Customer cable, power	3HAB 3560-NXA	7m, metal braid protection
XT5		Customer cable, signal	3HAA 3560-NKA	15m
XT6		Customer cable, power	3HAA 3560-NPA	15m
		Customer cable, signal	3HAB 3560-NWA	15m, metal braid protection
		Customer cable, power	3HAB 3560-NYA	15m, metal braid protection
XT5		Customer cable, signal	3HAA 3560-NLA	22m
XT6		Customer cable, power	3HAA 3560-NRA	22m
XT5		Customer cable, signal	3HAA 3560-NMA	30m
XT6		Customer cable, power	3HAA 3560-NSA	30m
EV4		Fan, transformer cooling	6480 096-5	24V DC
		Filter cartridge	3HAB 2780-1	

B2. Suggested Spare Parts List

B2.1 Axis 1

Part Number	Description	Robot Type	Units
3HAB4039-001	Motor Axis 1	All except 2.25	1
3HAB4043-001	Motor Axis 1	2.25PE-75	1
3HAB4079-001	Reduction Gear	2.25PE-75	1
5217687-022	Connector Housing	All	1
5217687-028	Guide Pin	All	1
YB560101-DV	Wall Socket C-conn.	All	1
YB560103-CE	Drive Board Axis 1-3	All	1

B2.2 Axis 2 & 3

Part Number	Description	Robot Type	Units
3HAA0001-ADY	Brake Release Unit	All	1
3HAB4040-001	Motor Axis 2-3	All except 2.25	1
3HAB4043-001	Motor Axis 2-3	2.25PE-75	1
3HAB4080-001	Reduction Gear	All except 2.25	1
3HAB4226-001	Reduction Gear	2.25PE-75	1
3HAB4259-001	Measure Card Unit	All	1
4944026-005	Battery Pack	All	1

B2.3 Lower Arm

Part Number	Description	Robot Type	Units
3HAB4216-001	Balancer, Type A, Standard	All	1
3HAB4218-001	Balancer, Type C, Shelf mount	All	1

Suggested Spare Parts List (Cont)

B2.4 Upper Arm

Part Number	Description	Robot Type	Units
21522012-430	O-Ring (Motor)	All	1
3HAB4195-001	Axis 4 Motor (120 kg)	All	1
3HAB4195-002	Axis 4 Motor (150 kg)	All	1
3HAB4196-001	Wrist Assy. (2.4 120 kg)	All	1
3HAB4196-002	Wrist Assy. (2.4 150 kg)	All	1
3HAB4236-001	Axis 4 Assy	All	1
YB560103-CD	Drive Boards Axis 4-6	All	1

B2.5 Cables

Part Number	Description	Robot Type	Units
3HAA0001-YR	Cable Axis 5	2.4m	1
3HAA0001-YS	Cable Axis 5	2.8-100, 3.0-All	1
3HAA0001-YT	Cable Axis 6	2.4m	1
3HAA0001-YU	Cable Axis 6	2.8-100, 3.0-All	1
3HAA0001-YX	Cable Motor 2	All	1
3HAA0001-YY	Cable Motor 3	All	1
3HAB4198-001	Cable Upper Arm	2.25PE-75	1
3HAB4248-001	Lower Cable NO cust. conn.	All	1
3HAB4249-001	Lower Cable WITH cust. conn.	All	1
3HAB4253-001	Cable Upper Arm	All except 2.25	1

Suggested Spare Parts List (Cont)

B2.6 Control

Part Number	Description	Rem	Units
3HAA3001-004	Contactor		1
3HAA3001-081	Auto Fuse (on transformer)		1
3HAA3003-019	Contactor		1
3HAA3563-AHA	Rectifier	DSQC 235B	1
3HAA3563-AUA	Power Supply	DSQC 258	1
3HAA3573-ADA	Memory Board 6MB	DSQC 303	1
3HAB2101-001	Programming Unit	10m	1
3HAB2210-001	Robot Computer	DSQC 300	1
3HAB2211-001	System Board	DSQC 256	1
3HAB2221-001	Memory Board 2MB	DSQC 312	1
3HAB2214-001	Combi I/O Board	S4	1
3HAB2219-001	Main Computer	DSQC 306	1
3HAB2480-001	Flexdriver Unit		1
3HAB5124-001	Filter for Transformer Fan		1
4944026-005	Battery for Robot Computer	S3 M91	1
5397038-001	Micro Switch		1
5672817-022	Time Fuse		1
6480096-005	Fan Unit		1
7820004-003	Filter, Air conditioner		1
YB560103-BD	Digital I/O Board	DSQC 223	1
YB560103-CD	Servo-Drive Unit	DSQC 236G	1
YB560103-CE	Servo-Drive Unit	DSQC 236T	1

NOTES

APPENDIX C

**CONNECTORS &
CABLES**

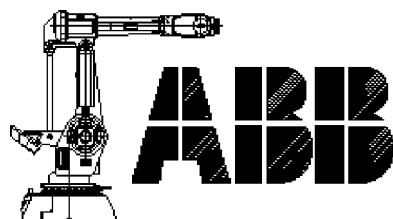

Connectors & Cables

Table of Contents

C.	CONNECTORS & CABLES.....	C-3
C1.	Robot Arm Cables	C-3
C2.	Control Cabinet Cables	C-4
C3.	Miscellaneous Cables	C-6
C4.	Signal Cable, Axis 1	C-7
C5.	Signal Cable, Axis 5	C-8
C6.	Power Cable, Axis 5	C-9
C7.	Signal Cable, Axis 6	C-10
C8.	Power Cable, Axis 6	C-11
C9.	Signal Cable, Axis 2	C-12
C10.	Power Cable, Axis 2	C-13
C11.	Signal Cable, Axis 3	C-14
C12.	Power Cable, Axis 3	C-15
C13.	Control Cable, Signal	C-16
C14.	Control Cable, Power	C-17
C15.	Customer Cable, Signal	C-18
C16.	Customer Cable, Power	C-19
C17.	Lower Cable Assembly	C-20
C18.	Upper Cable Assembly	C-22
C19.	Cable, Customer Connection	C-24
C20.	Cable, M94A	C-25
C21.	Cable, M94A Control Wiring X-Reference ..	C-30
C22.	Connectors	C-35

NOTES

C. CONNECTORS & CABLES

C1. Robot Arm Cables

From: Component	Connector A	ABB Cable No.	Connector B	To:Component
SMB 1-2	R2.SMB1-2 (X-3)	3HAB4250-1	R3.FB1	Axis 1 Resolver
Upper Cable Assy	R3.FB5	3HAA0001-ABY	R4.FB5	Axis 5 Resolver
Upper Cable Assy	R3.MP5	3HAA0001-ABY	R4.MP5	Axis 5 Power
Upper Cable Assy	R3.FB6	3HAA0001-ACA	R4.FB6	Axis 6 Resolver
Upper Cable Assy	R3.MP6	3HAA0001-ACA	R4.MP6R4.PTC6	Axis 6 Power
Lower Cable Assy	R2.SMB1-4 (X-4)	3HAB4252-2	R3.FB2R2.SMB3	Axis 2 Resolver/SMB 3
Lower Cable Assy	R2.MP2	3HAB4252-2	R3.MP2	Axis 2 Power
Lower Cable Assy	R2.SMB3	3HAA0001-ACD	R3.FB3	Axis 3 Resolver
Lower Cable Assy	R2.MP3	3HAA0001-ACD	R3.MP3	Axis 3 Power
Ctrl Cabinet	XP2	3HAB2678-6	R1.SMB	Robot Base
Ctrl Cabinet	XP1	3HAB2684-7	R1.MP	Robot Base
Ctrl Cabinet	XP5	3HAA3560-NJF	R1.CS	Robot Base
Ctrl Cabinet	XP6	3HAA3560-NNF	R1.CP	Robot Base
		Lower Cable Ass'y		
Robot Base Connections Axis Power	R1.MP	3HAB4249-2	R2.FAN R2.MP1 R2.MP2 R2.MP3 R2.MP4 R2.MP5-6	Fan Axis 1 - Power Axis 2 - Power Axis 3 - Power Axis 4 - Power Axis 5/6 Power
Axis Signal	R1.SMB		R2.SMB	Axis Signal
Cust. Signal	R1.CS		R2.CS	Customer Signal
Cust. Pwr	R1.CP		R2.CP	Customer Power
		Upper Cable Ass'y		
Customer Signal	R2.CS	3HAB4254-2	R3.CS	Customer Signal
Customer Power	R2.CP		R3.CP	Customer Power
Axis Signal	R2.SMB3-6		R3.FB4R3.FB5R3.FB6	Axis Signal
Axis 4 Power	R2.MP4		R3.MP4	Axis 4 Power
Axis 5/6 Power	R2.MP5-6		R3.MP5R3.MP6	Axis 5/6 Power
		(OPTIONAL) Position Sw. Cable		
Ctrl Cabinet	XP8	3HAB2832-1	R1.SW	Robot Base

C2. Control Cabinet Cables

From: Component	Connector A	ABB Cable No.	Connector B	To: Component
Control Cabinet	XS/XP8	3HAB 2830-5	XT8	Terminal Strip
Control Cabinet	XS/XP6	3HAA 3560-NUB	XT6	
	XS/XP5		XT5	
Control Panel	SA.1	3HAA 3560-HRF	AP80.X34 SA.1 XP17	Back Plane
	SA.3 SA.4 SA.2		AP80.X34	
System Board	AP41.XS1	3HAB 2661-7	XS22 XS3 AP80.X35 KM3 XS18 KM2 KM3	Ext Axis Customer Conn. System Board Motor Contactor PCT Motor Contactor Motor Contactor
Varistor Diode Unit	AP60.RV1		KM3	Motor Contactors
	AP60.RV2		KM2	
	AP60.RV4		KM2	
	AP60.V1		PT	Duty Counter
System Board Customer	AP80.X35		XS3 XS18 AP41.XS1	Customer/ PTC/ System Board
Drive	AP9.XS1		AP41.XS1	" "
Floppy Drive	D1.1		XS17 AP80.X22	Floppy Power/ Signal
Drive Fuse	FS1		KM1 GS1.XS1	Motor Contactor Power Supply
Power Supply	GS1.XS1		PT XS18 XS22 XS3 KM1 AP80.X22 XP18 PE	Duty Time Counter PTC External Axis Customer Ext. Motor Contact Floppy Disk Pwr PTC Earth
Motor Contactor	KM1		KM2 GS1.XS1 KM1	Motor Contactor Power Supply Motor Contactor
Motor Contactor	KM2		AP9.XS1 TM1.XT1 KM2 XS3 KM1	DC-Link Transformer Motor Contactor Customer Conn. Motor Contactor

Control Cabinet Cables (Cont)

From: Component	Connector A	ABB Cable No.	Connector B	To:Component
Super. Contactor	KM3		KM4 KM2 KM1 XS22 PE KM3	Brake Contactor Motor Contactor Motor Contactor Ext Axis Pwr Earth Super. Contactor
Brake Contactor	KM4		XS22 AP60.RV4 XS3 KM3	Ext Axis Pwr Varistor & Diode Cust Connection Super Contactor
Cust Sys Board	AP80.X35		XS3	Cust. Connection
Transformer, Mains	TM1		XP18 GS1.XS1 KM2	PTC Power Supply Motor Contactor
Ext Axes Control Signal Extension	XP22		XS22	Ext Axis Con Sig
Control Cable Pwr	XS1		AP1.XS1 AP2.XS1 AP3.XS1 KM4 XP18 Z2 XP18 KM4 AP3.XS1 AP60.V3 XS22	Drive Axis Power Drive Axis Power Drive Axis Power Brake Contactor PTC Filter Lim Sw PTC Brake Contactor Drive Axis Power Var. & Diode Unit Ext Axis Con Sig
PTC	XS18		AP41.XS1	System Board
Ext Axes Control Signal Extension	XS22		XS22 XP18	Ext Axis Con Sig PTC
Customer Connection	XS3		AP60.V3 AP80.X35 XS3 AP80.X35 AP41.XS1 AP41.XS5 KM1 KM4 KM3 XS17 PE	Var & Diode Unit System Board Cust. Connect Sys. Board Cus. Sys. Board Sys. Board Motor Contactor Brake Contactor PTC Mode Switch Earth
Filter - Lim Sw. Rob	Z2		XS3	Cust Connect

C3. Miscellaneous Cables

Computer Link	XB1	3HAB 2807-7	AP80.X5	Data Ports
Teach Pendant	X1	3HAB 2103-7	X10.1	Teach Pendant
Control Cabinet	XS20	3HAA 3560-LXF	XP20	Prog Unit

C4. Signal Cable, Axis 1
3HAB-4250-1
Serial Measurement Board to Axis 1 Resolver

R2.SMB1-2 (X3)

Pin	Signal/Description
1	
3	0V EXC1
6	Y1
7	X1
10	EXC1
13	0V Y1
14	0V X1

R3.FB1

Pin	Signal/Description
A	X1
B	0V X1
C	Y1
D	0V Y1
E	0V EXC1
F	EXC1
G	Shield

CONNECTOR TYPE

DB-15

BR-8

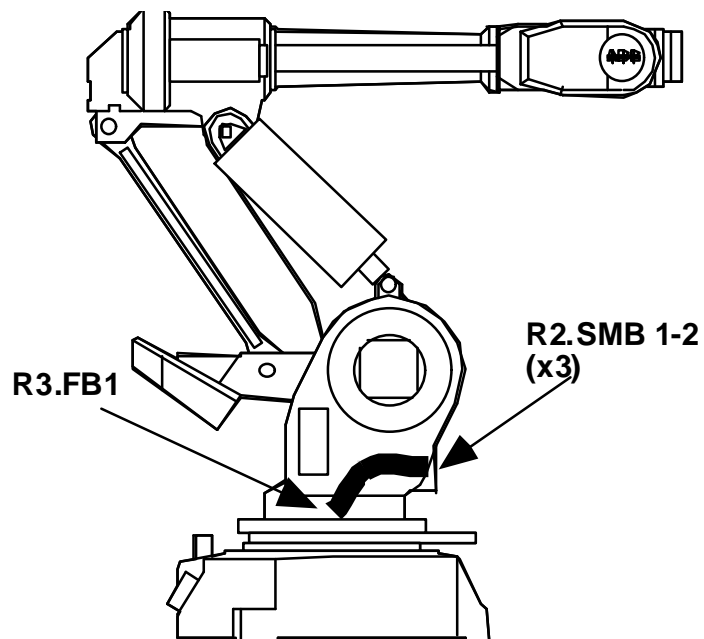

C5. Signal Cable, Axis 5
3HAA-0001-ABY
Upper Arm Connector to Axis 5 Resolver

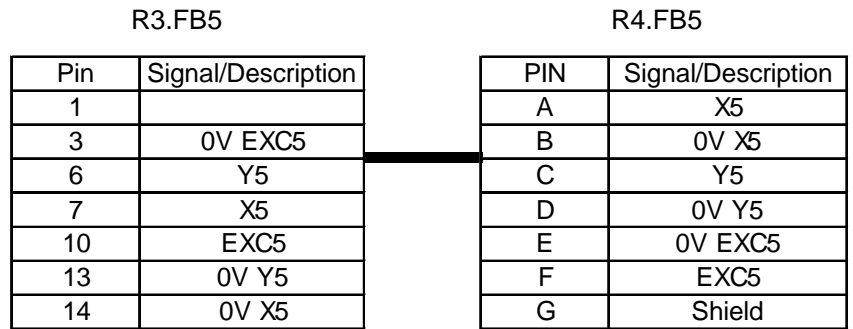

CONNECTOR TYPE

DB-15

BR-8

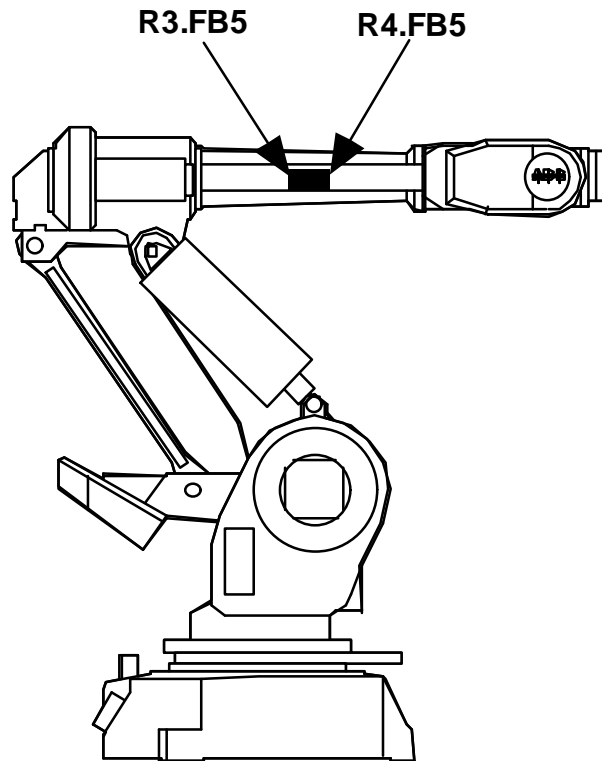

C6. Power Cable, Axis 5
3HAA-0001-ABY
Upper Arm Connector to Axis 5 Motor

R3.MP5

Pin	Signal/Description
1	M5R1
2	M5R2
3	M5S1
4	M5S2
5	M5T1
6	M5T2
7	PE
8	PE
9	PTC M5
10	PTC M5
11	BU+
12	BU-

R4.MP5

PIN	Signal/Description
A	M5R1
B	M5R2
C	M5S1
D	M5S2
E	M5T1
F	M5T2
G	PE
H	PE
J	PTC M5
K	PTC M5
L	BU+
M	BU-

CONNECTOR TYPE

BS-12

BR-12

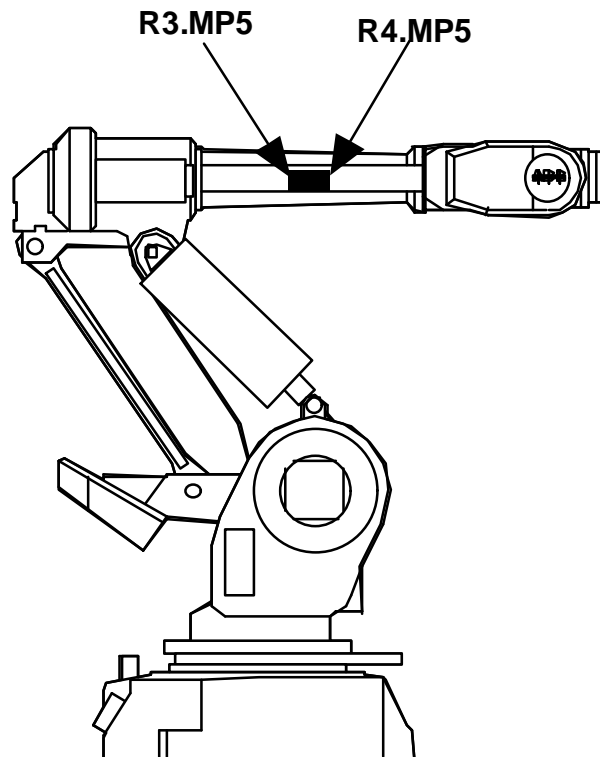

C7. Signal Cable, Axis 6
3HAA-0001-ACA
Upper Arm Connector to Axis 6 Resolver

R3.FB6		R4.FB6	
Pin	Signal/Description	Pin	Signal/Description
1		1	
3	0V EXC6	3	0V EXC6
6	Y6	6	Y6
7	X6	7	X6
10	EXC6	10	EXC6
13	0V Y6	13	0V Y6
14	0V X6	14	0V X6

CONNECTOR TYPE

DB 15

DB-15

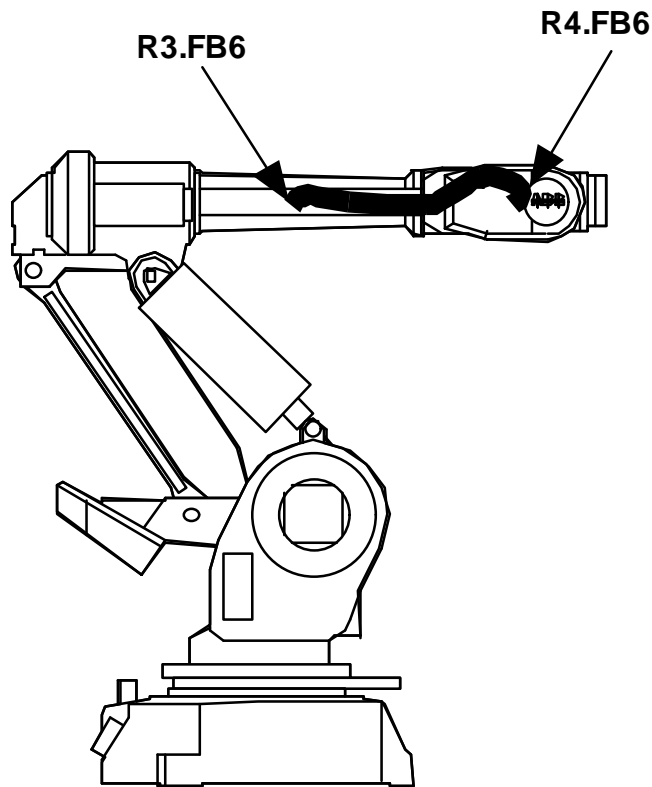

**C8. Power Cable, Axis 6
3HAA-0001-ACA
Upper Arm Connector to Axis 6 Motor**

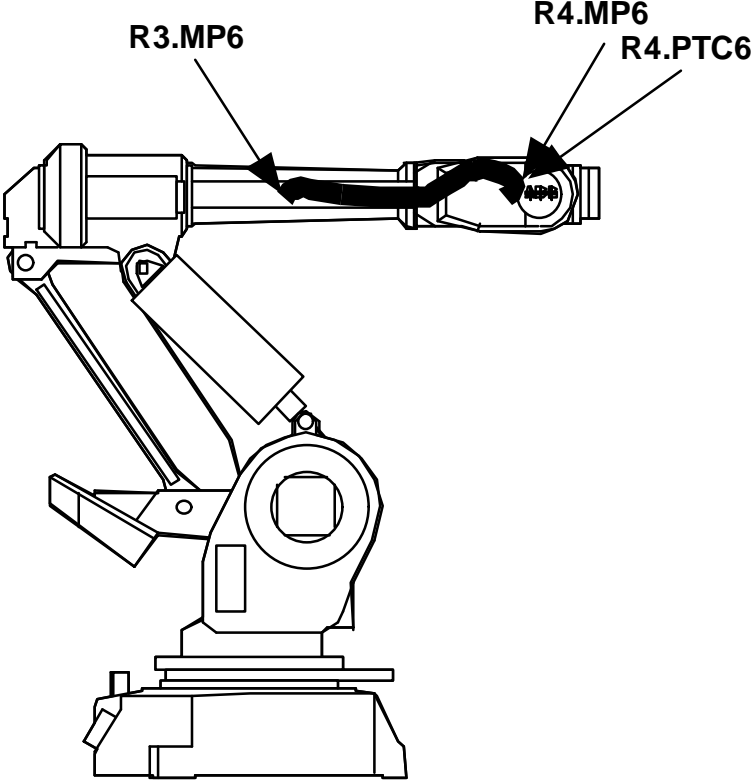
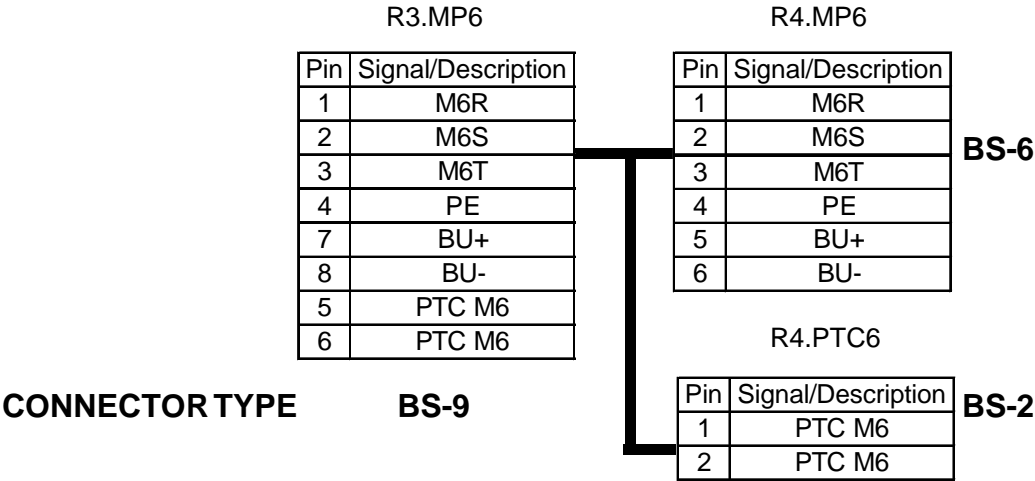

C9. Signal Cable, Axis 2
3HAB-4252-2
Serial Measurement Board Connector to Axis 2 & 3 Resolvers

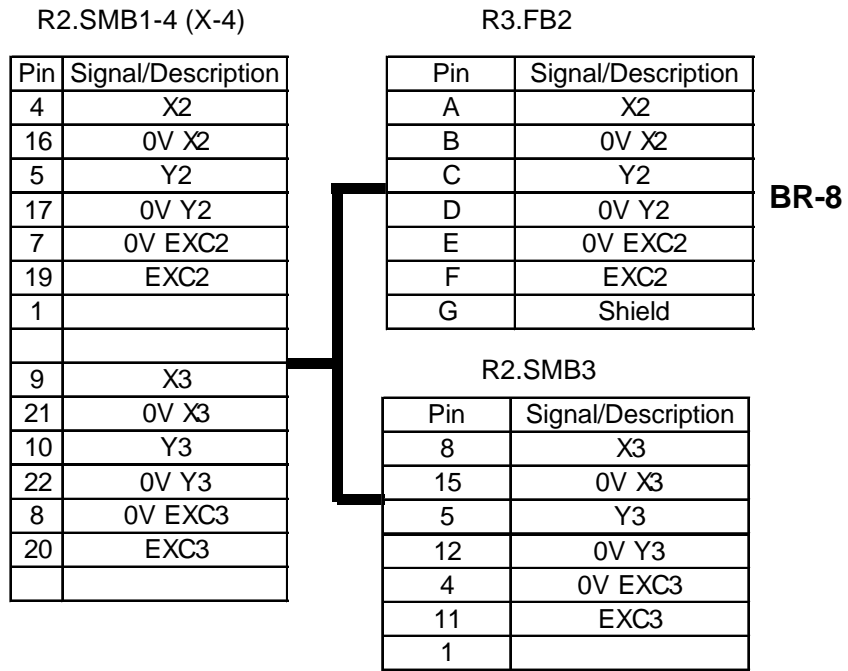

CONNECTOR TYPE

DB-25

DB-15

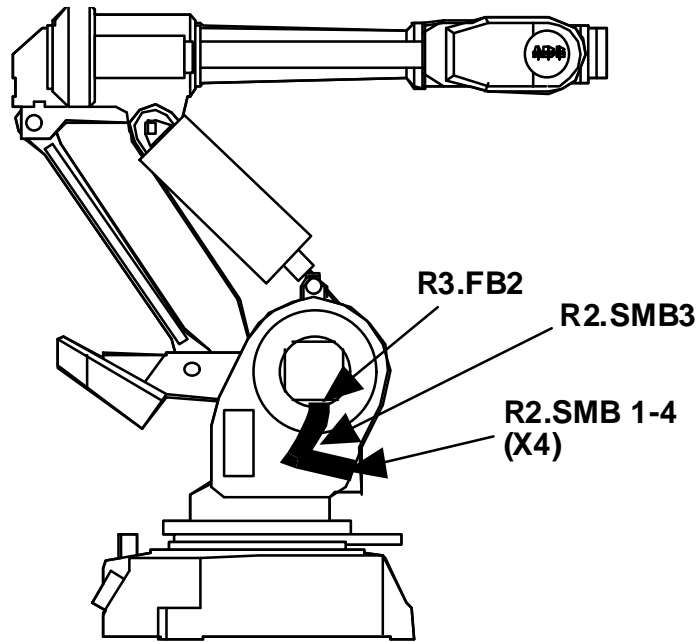

C10. Power Cable, Axis 2
3HAB-4252-2
Lower Arm Connector to Axis 2 Motor

R2.MP2		R3.MP2	
Pin	Signal/Description	Pin	Signal/Description
1	M2R1	A	M2R1
2	M2R2	B	M2R2
3	M2S1	C	M2S1
4	M2S2	D	M2S2
5	M2T1	E	M2T1
6	M2T2	F	M2T2
7	PE	G	PE
8	PE	H	PE
9	PTC M2	J	PTC M2
10	PTC M2	K	PTC M2
11	BU+	L	BU+
12	BU-	M	BU-

CONNECTOR TYPE

BS-12

BR-12

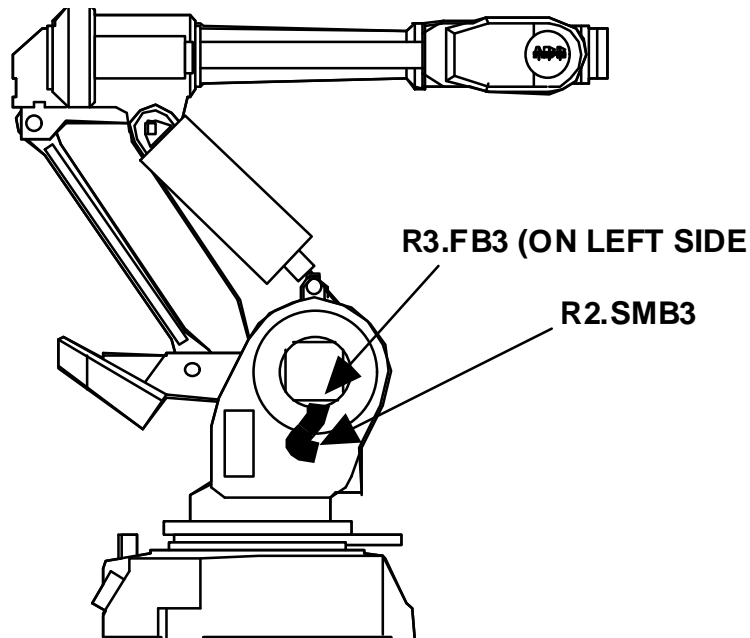

C11. Signal Cable, Axis 3
3HAA-0001-ACD
Lower Arm Connector to Axis 3 Resolver

R2.SMB3		R3.FB3	
Pin	Signal/Description	Pin	Signal/Description
8	X3	A	X3
15	0V X3	B	0V X3
5	Y3	C	Y3
12	0V Y3	D	0V Y3
4	0V EXC3	E	0V EXC3
11	EXC3	F	EXC3
1		G	Shield

CONNECTOR TYPE DB-15 BR-8

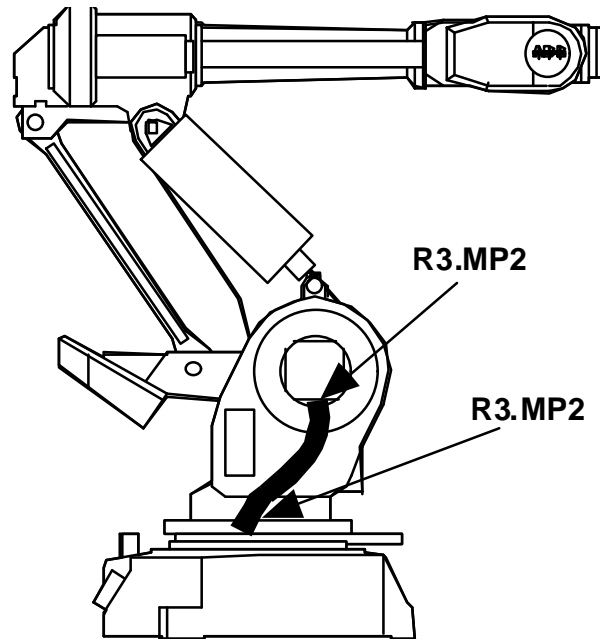

C12. Power Cable, Axis 3
3HAA-0001-ACD
Lower Arm Connector to Axis 3 Motor

R2.MP3		R3.MP3	
Pin	Signal/Description	Pin	Signal/Description
1	M3R1	A	M3R1
2	M3R2	B	M3R2
3	M3S1	C	M3S1
4	M3S2	D	M3S2
5	M3T1	E	M3T1
6	M3T2	F	M3T2
7	PE	G	PE
8	PE	H	PE
9	PTC M3	J	PTC M3
10	PTC M3	K	PTC M3
11	BU+	L	BU+
12	BU-	M	BU-

CONNECTOR TYPE

BS-12

BR-12

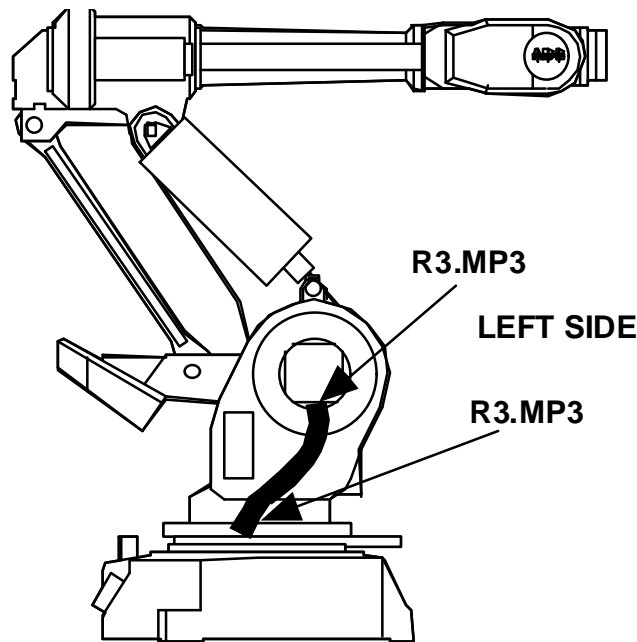

C13. Control Cable, Signal
3HAB-2678-6
Cable runs from Control Cabinet to Robot

XP2		R1.SMB	
Pin	Signal/Description	Pin	Signal/Description
A	RCO	A	RCO
B	RCO-N	B	RCO-N
C	RCI	C	RCI
D	RCI-N	D	RCI-N
E	0V	E	0V
F	+24V	F	+24V
J	BATT-	J	BATT-
K	BATT+	K	BATT+
L	BATT	L	BATT
M		M	

CONNECTOR TYPE BS-12
BR-12

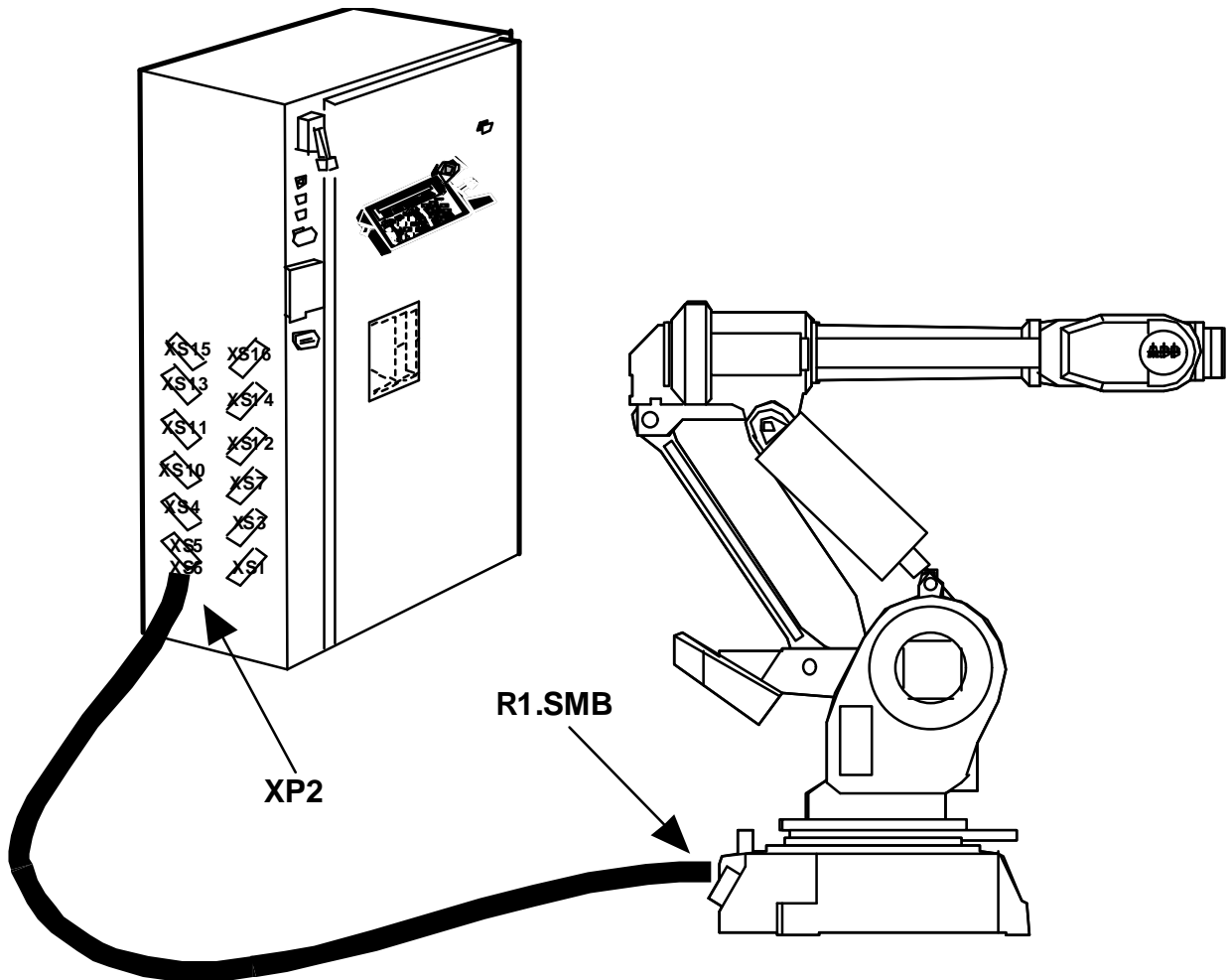

C14. Control Cable, Power
3HAB-2684-7
Cable runs from Control Cabinet to Robot

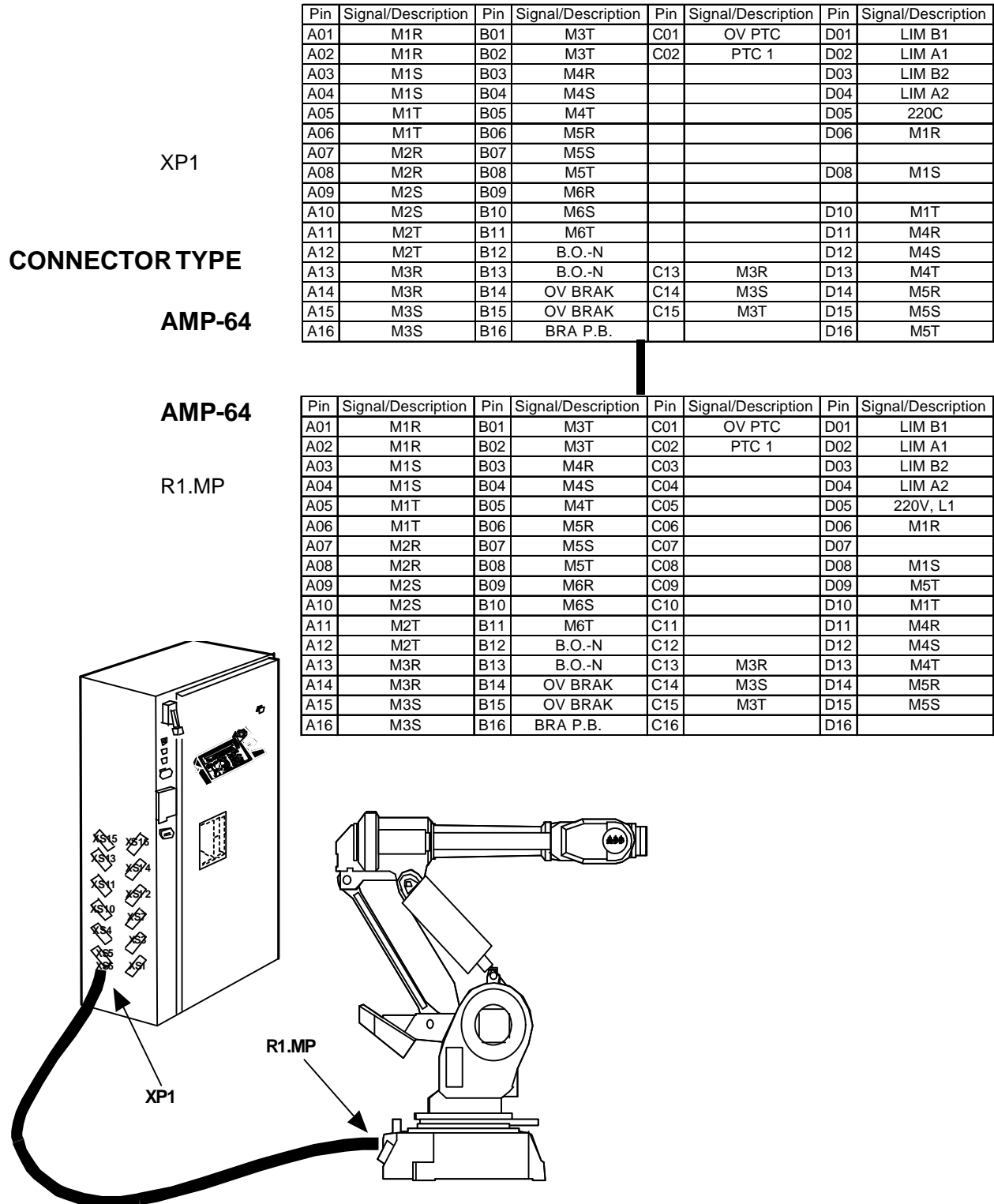

C15. Customer Cable, Signal
3HAA-3560-NJF
Cable runs from Control Cabinet to Robot

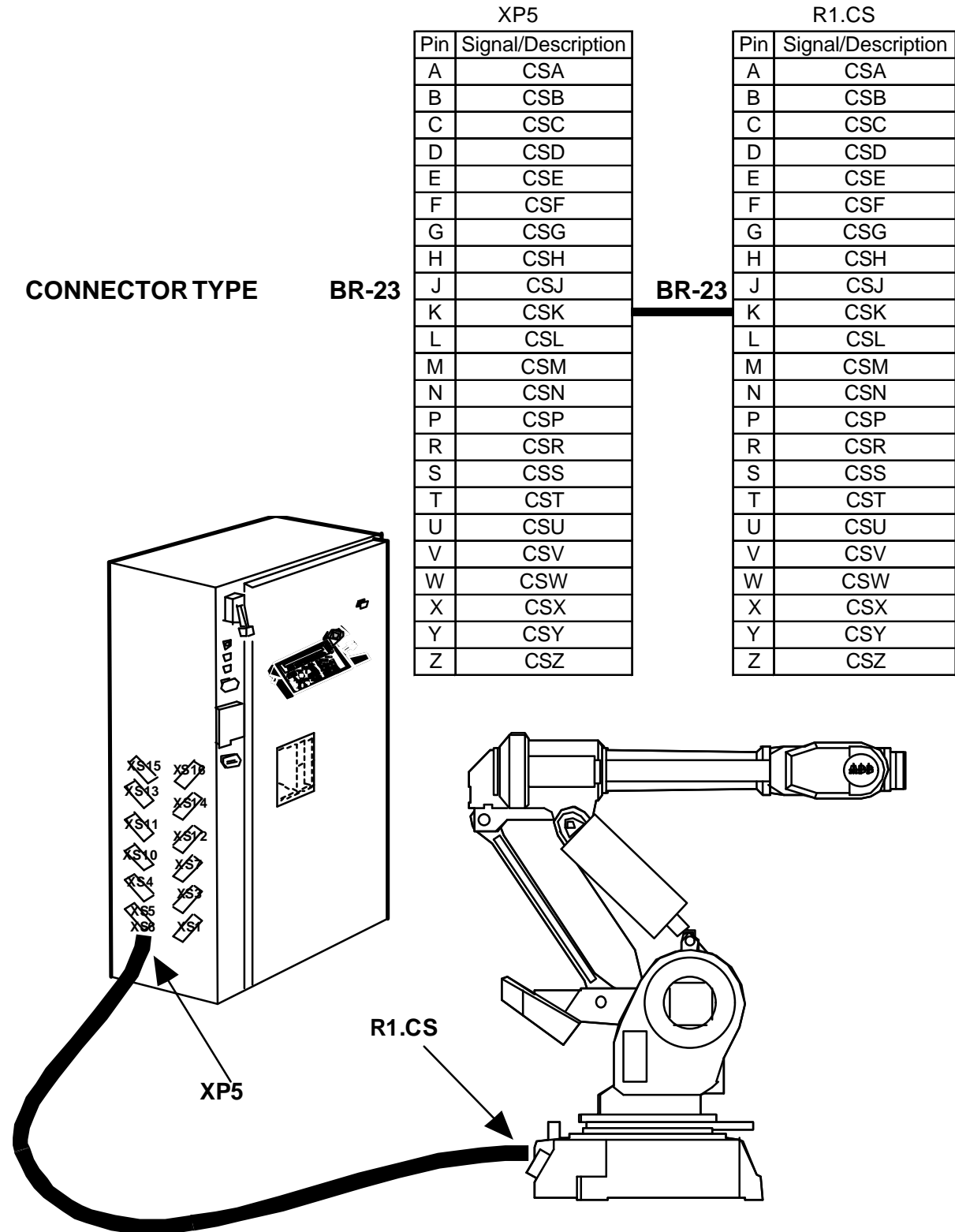

C16. Customer Cable, Power
3HAA-3560-NNF
Cable runs from Control Cabinet to Robot

XP6		R1.CP	
Pin	Signal/Description	Pin	Signal/Description
A	CPA	A	CPA
B	CPB	B	CPB
C	CPC	C	CPC
D	CPD	D	CPD
E	CPE	E	CPE
F	CPF	F	CPF
J	CPJ	J	CPJ
K	CPK	K	CPK
L	CPL	L	CPL
M	CPM	M	CPM
H	PIN		PIN

CONNECTOR TYPE

BR-19

BR-19

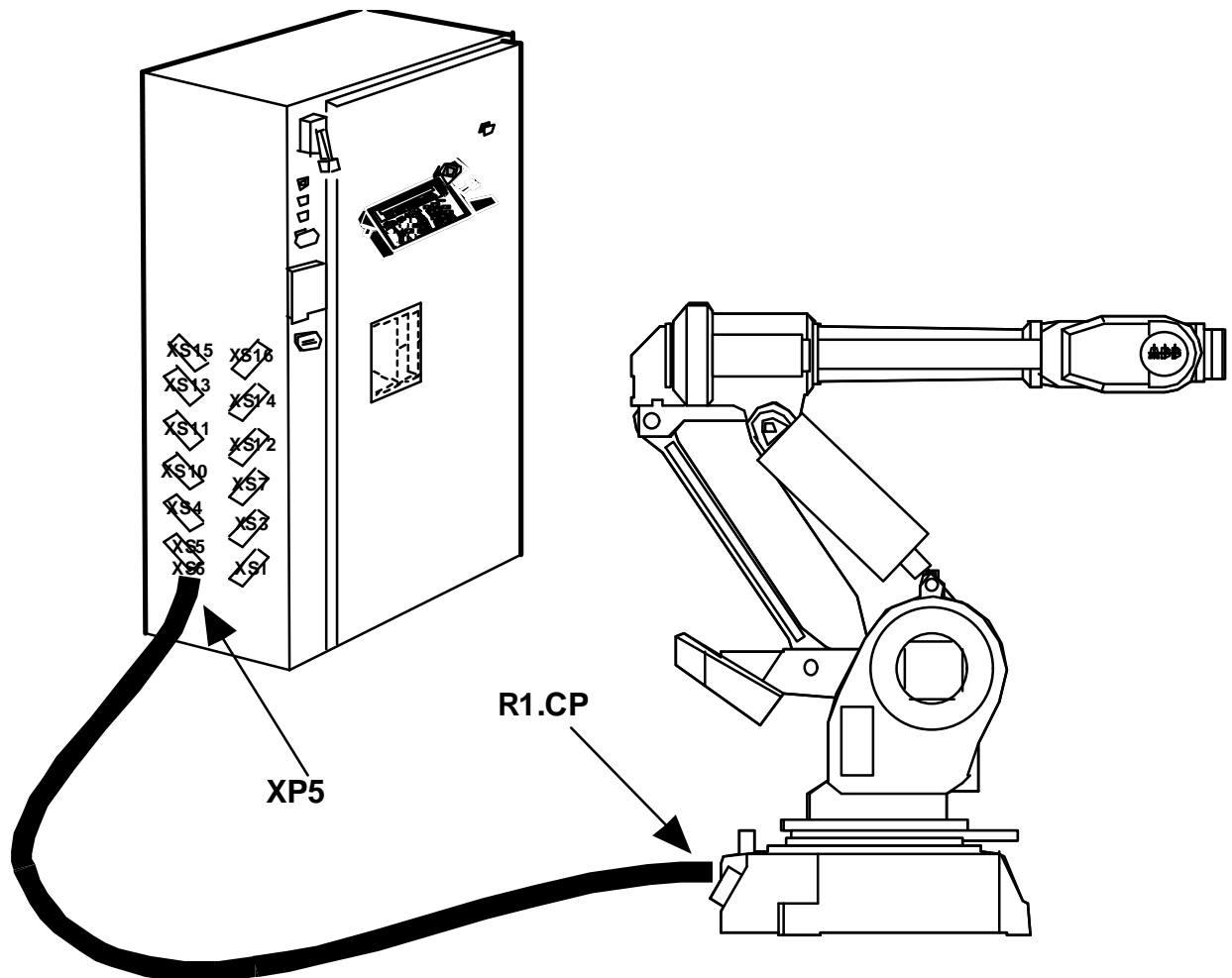

**C17. Lower Cable Assembly
3HAB-4249-2**

Cable runs from Back of Robot through Base of Robot
R1.MP

Pin	Signal/Desc	Pin	Signal/Desc	Pin	Signal/Desc	Pin	Signal/Desc
A01	M1R	B01	M3T	C01	OV PTC	D01	LIM B1
A02	M1R	B02	M3T	C02	PTC 1	D02	LIM A1
A03	M1S	B03	M4R	C03	jumpered to C4	D03	LIM B2
A04	M1S	B04	M4S	C04	jumpered to C3	D04	LIM A2
A05	M1T	B05	M4T	C05	jumpered to C6	D05	220V, L1
A06	M1T	B06	M5R	C06	jumpered to C5	D06	M1R
A07	M2R	B07	M5S	C07	jumpered to C8	D07	
A08	M2R	B08	M5T	C08	jumpered to C7	D08	M1S
A09	M2S	B09	M6R	C09	jumpered to C10	D09	M5T
A10	M2S	B10	M6S	C10	jumpered to C9	D10	M1T
A11	M2T	B11	M6T	C11	jumpered to C12	D11	M4R
A12	M2T	B12	B.O.-N	C12	jumpered to C11	D12	M4S
A13	M3R	B13	B.O.-N	C13	M3R	D13	M4T
A14	M3R	B14	OV BRAK	C14	M3S	D14	M5R
A15	M3S	B15	OV BRAK	C15	M3T	D15	M5S
A16	M3S	B16	BRA P.B.	C16		D16	

R2.FAN

Pin	Signal/Desc
1	220V, L1
2	0V, N
3	PE

R3.BU1-6 (R3.X8)

Pin	Signal/Desc
1	B.O.-N
2	B.O.-N
3	OV BRAK
4	OV BRAK
5	BRA P.B.

CONNECTOR TYPE AMP-64

R2.MP5-6

Pin	Signal/Desc
1	M5R
2	M5R
3	M5S
4	M5S
5	M5T
6	M5T
7	PE
8	PE
9	PTC M5
10	PTC M5
11	24 VDC BRAKE
12	0 VDC BRAKE
13	M6R
14	M6S
15	M6T
16	PE
17	PTC M1
18	PTC M6
19	24 VDC BRAKE
20	0 VDC BRAKE

R2.MP2

Pin	Signal/Desc
1	M2R
2	M2R
3	M2S
4	M2S
5	M2T
6	M2T
7	PE
8	PE
9	PTC M2
10	PTC M2
11	24 VDC BRAKE
12	0 VDC BRAKE

R3.MP3

Pin	Signal/Desc
A	M3R
B	M3R
C	M3S
D	M3S
E	M3T
F	M3T
G	PE
H	PE
J	PTC M3
K	PTC M3
L	24 VDC BRAKE
M	0 VDC BRAKE

R4.MP4

Pin	Signal/Desc
1	M4R
2	M4R
3	M4S
4	M4S
5	M4T
6	M4T
7	PE
8	PE
9	PTC M4
10	PTC M4
11	24 VDC BRAKE
12	0 VDC BRAKE

R2.MP1

Pin	Signal/Desc
A	M1R
B	M1R
C	M1S
D	M1S
E	M1T
F	M1T
G	PE
H	PE
J	PTCM1
K	OV PTC
L	+24 BRAKE
M	0V BRAKE
N	M1R
S	M1S
U	M1T
V	PE

BS-12

BR-12

BS-12

BR-23

BS-24

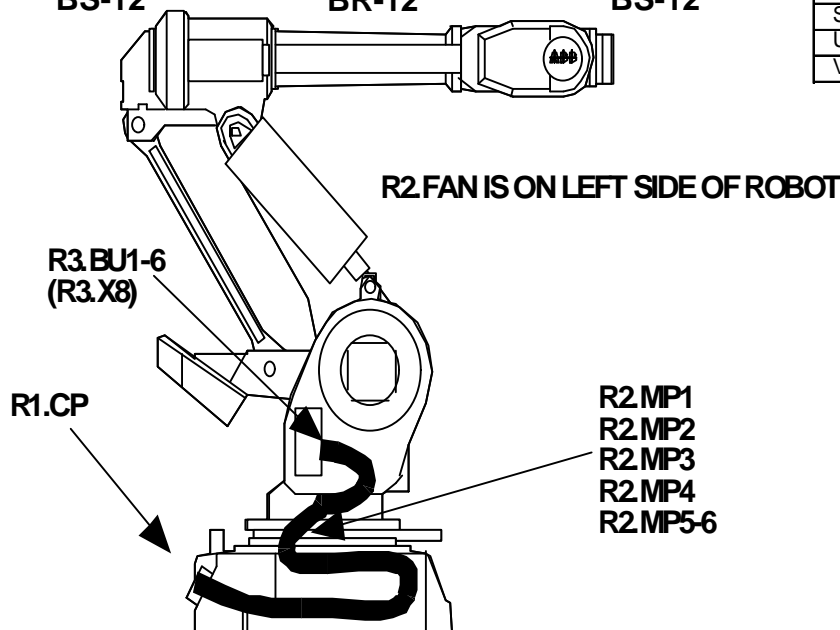

Lower Cable Assembly (Cont)

3HAB-4249-2

Cable runs from Back of Robot through Base of Robot

R1.SMB		R2.SMB		R1.CS		R2.CS	
Pin	Signal/Desc	Pin	Signal/Desc	Pin	Signal/Desc	Pin	Signal/Desc
A	SDI	9	SDI	A	CSA	1	CSA
B	SDI-N	5	SDI-N	B	CSB	2	CSB
C	SDO	8	SDO	C	CSC	3	CSC
D	SDO-N	4	SDO-N	D	CSD	4	CSD
E	0V	3	0V	E	CSE	5	CSE
F	24V	7	24V	F	CSF	6	CSF
L	BAT LD	2	BAT LD	G	CSG	7	CSG
K	+Batsup	6	+Batsup	H	CSH	8	CSH
J	jumpered to E	1	0V	J	CSJ	9	CSJ

BR-12 **DB-9**

R1.CP		R2.CP		R1.CS		R2.CS	
Pin	Signal/Desc	Pin	Signal/Desc	Pin	Signal/Desc	Pin	Signal/Desc
A	CPA	1	CPA	M	CSM	12	CSM
B	CPB	2	CPB	N	CSN	13	CSN
C	CPC	3	CPC	P	CSP	14	CSP
D	CPD	4	CPD	R	CSR	15	CSR
E	CPE	5	CPE	S	CSC	16	CSC
F	CPF	6	CPF	T	CST	17	CST
G	CPG	7	CPG	U	CSU	18	CSU
J	CPJ	9	CPJ	V	CSV	19	CSV
K	CPK	10	CPK	W	CSW	20	CSW
L	CPL	11	CPL	X	CSX	21	CSX
M	CPM	12	CPM	Y	CSY	22	CSY
				Z	CSZ	23	CSZ

BR-12 **BR12** **BR-23** **BR-23**

CONNECTOR TYPE

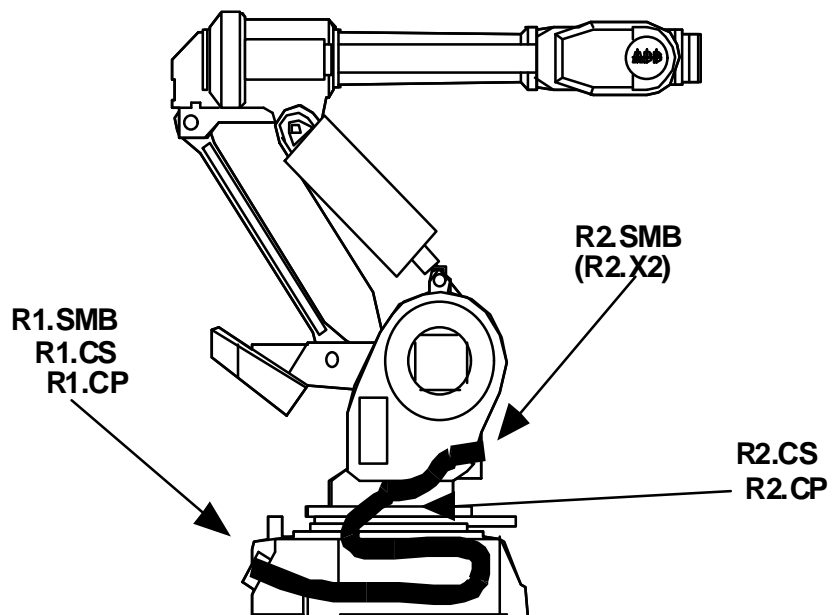

**C18. Upper Cable Assembly
3HAB-4254-2**

Cables run from Base Casting through Robot Arm

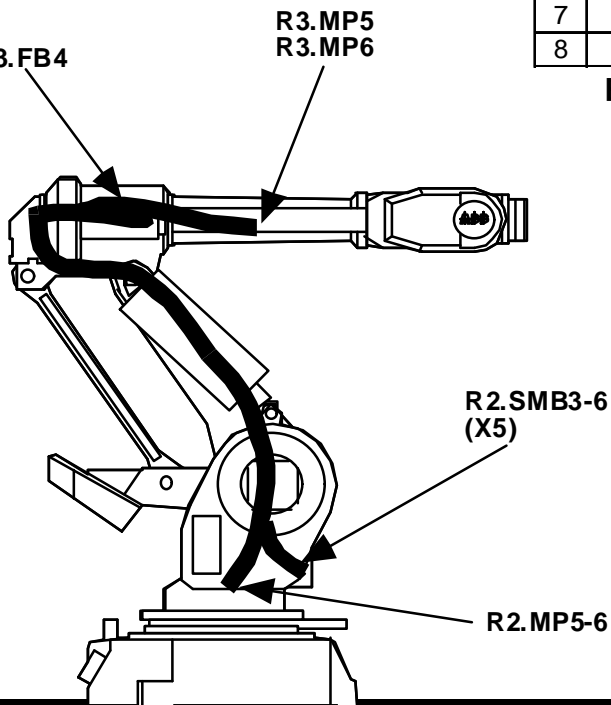
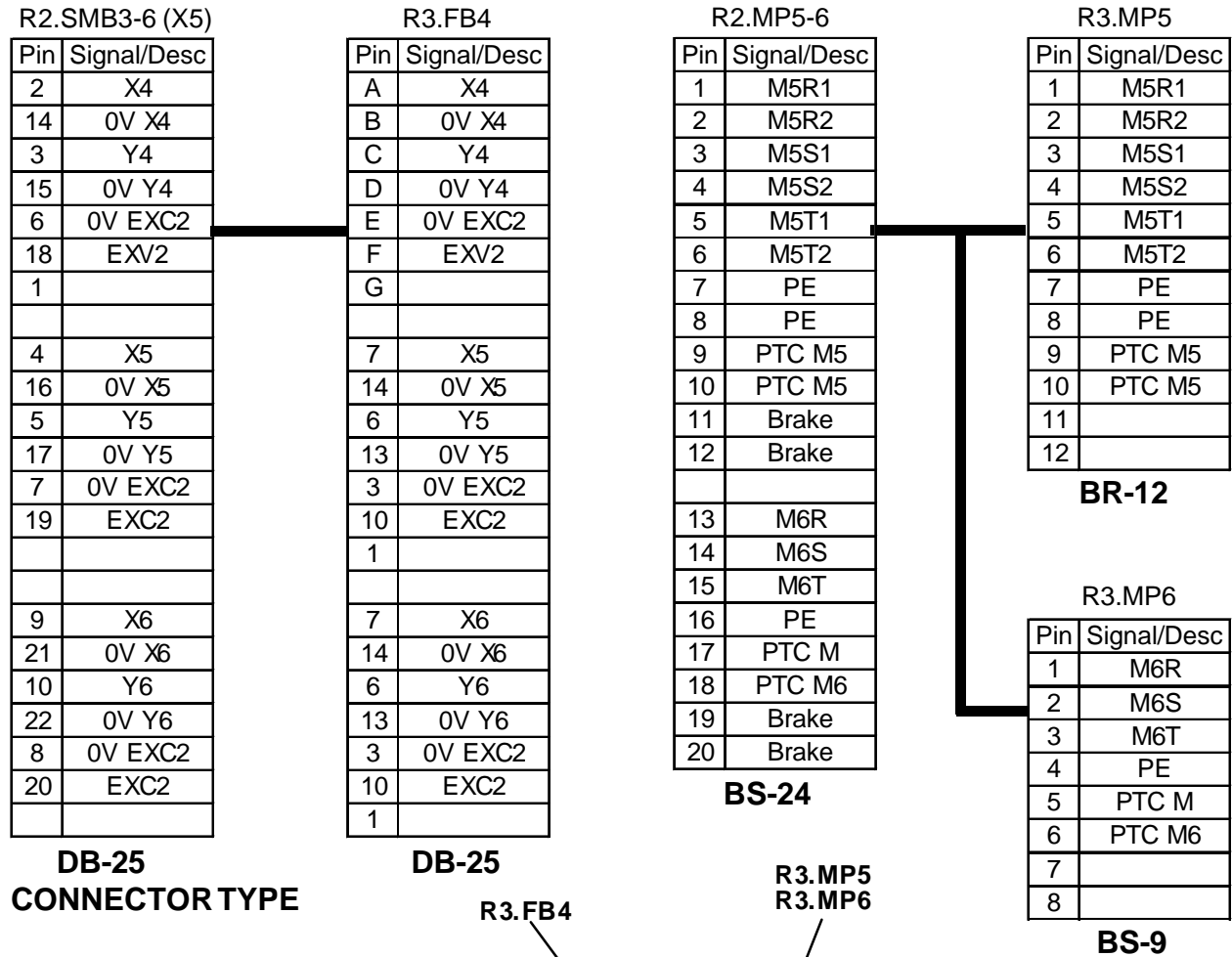

Upper Cable Assembly (Cont)

3HAB-4254-2

Cables run from Base Casting through Robot Arm

R2.CS		R3.CS		R2.CP		R3.CP	
Pin	Signal/Desc	Pin	Signal/Desc	Pin	Signal/Desc	Pin	Signal/Desc
A	CSA	A	CSA	A	CPA	A	CPA
B	CSB	B	CSB	B	CPB	B	CPB
C	CSC	C	CSC	C	CPC	C	CPC
D	CSD	D	CSD	D	CPD	D	CPD
E	CSE	E	CSE	E	CPE	E	CPE
F	CSF	F	CSF	F	CPF	F	CPF
G	CSG	G	CSG	G	CPG	G	CPG
H	CSH	H	CSH	J	CPJ	J	CPJ
J	CSJ	J	CSJ	K	CPK	K	CPK
K	CSK	K	CSK	L	CPL	L	CPL
L	CSL	L	CSL	M	CPM	M	CPM
M	CSM	M	CSM				
N	CSN	N	CSN				
P	CSP	P	CSP				
R	CSR	R	CSR				
S	CSS	S	CSS				
T	CST	T	CST				
U	CSU	U	CSU				
V	CSV	V	CSV				
W	CSW	W	CSW				
X	CSX	X	CSX				
Y	CSY	Y	CSY				
Z	CSZ	Z	CSZ				

BR-12

BR-12

**BR-23
CONNECTOR TYPE**

BR-23

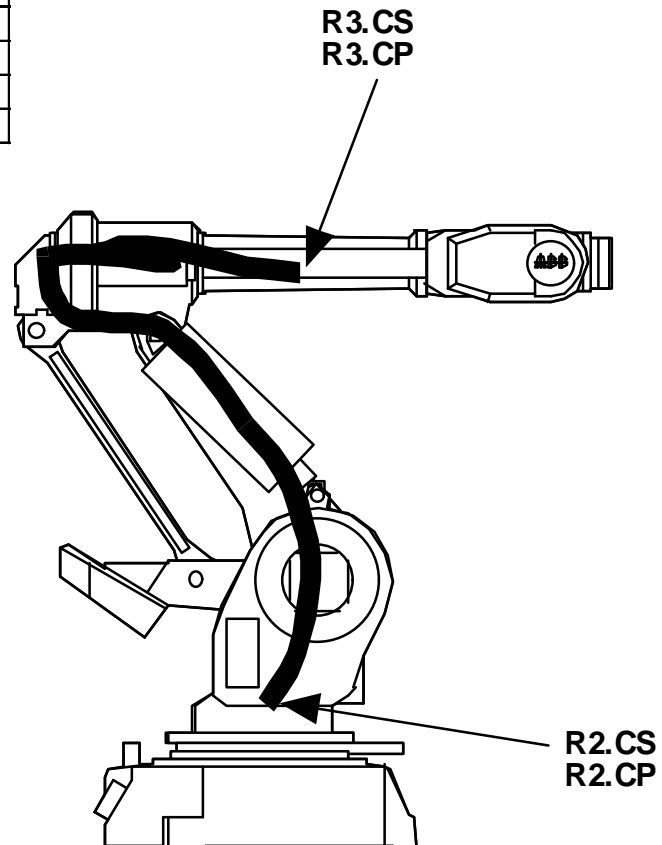

C19. Cable, Customer Connection

XS/XP6	
Pin	Signal/Desc
A	CPA
B	CPB
C	CPC
D	CPD
E	CPE
F	CPF
J	CPJ
K	CPK
L	CPL
M	CPM

XT6	
Pin	Signal/Desc
1	CPA
2	CPB
3	CPC
4	CPD
5	CPE
6	CPF
7	CPJ
8	CPK
9	CPL
10	CPM

XS/XP5	
Pin	Signal/Desc
A	CSA
B	CSB
C	CSC
D	CSD
E	CSE
F	CSF
G	CSG
H	CSH
J	CSJ
K	CSK
L	CSL
M	CSM
N	CSN
P	CSP
R	CSR
S	CSS
T	CST
U	CSU
V	CSV
W	CSW
X	CSX
Y	CSY
Z	CSZ

XT5	
Pin	Signal/Desc
1	CSA
2	CSB
3	CSC
4	CSD
5	CSE
6	CSF
7	CSG
8	CSH
9	CSJ
10	CSK
11	CSL
12	CSM
13	CSN
14	CSP
15	CSR
16	CSS
17	CST
18	CSU
19	CSV
20	CSW
21	CSX
22	CSY
23	CSZ

**BR-12
CONNECTOR TYPE**

Terminal

**BR-12
CONNECTOR TYPE**

Terminal

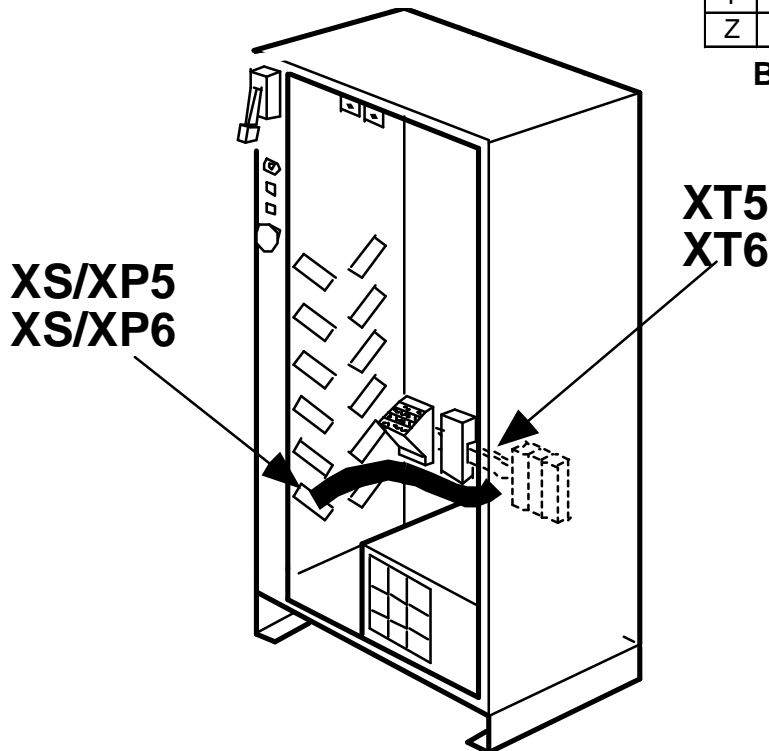

C20. Cable, M94A

From Connector	Type	PIN	Description	To Connector	Type	PIN
AP41.XS1	EDG96	A22	PTC/M7A	XS22	BS18	11
AP41.XS1	EDG96	A1	SENS/1	XS3	AMP64	D10
AP41.XS1	EDG96	C1	SENS/2	XS3	AMP64	D11
AP41.XS1	EDG96	A2	SENS/3	XS3	AMP64	D12
AP41.XS1	EDG96	C2	0V/SENS	XS3	AMP64	D13
AP41.XS1	EDG96	C12	MAN	AP80.X35	BS-24	18
AP41.XS1	EDG96	C11	MAN/FS	AP80.X35	BS-24	17
AP41.XS1	EDG96	C10	AUTO	AP80.X35	BS-24	19
AP41.XS1	EDG96	A12	ENDEV	AP80.X35	BS-24	24
AP41.XS1	EDG96	A14	MSTOP1	XS3	AMP64	A2
AP41.XS1	EDG96	A13	ASTOP1	XS3	AMP64	A4
AP41.XS1	EDG96	C30	BRAKE/REL	KM3	TERM.	22
AP41.XS1	EDG96	A19	PTC/M1	XS18	BS18	1
AP41.XS1	EDG96	C22	POWER/OK	XS3	AMP64	C12
AP41.XS1	EDG96	C29	CHAIN2	KM2	TERM.	43
AP41.XS1	EDG96	C28	CHAIN1	KM3	TERM.	33
AP41.XS1	EDG96	A23	MON	KM2	TERM.	7
AP41.XS1	EDG96	C23	MOFF	KM1	TERM.	1
AP60.RV1	TERM.	6	0V	KM3	TERM.	54
AP60.RV2	TERM.	7		KM2	TERM.	A2
AP60.RV2	TERM.	2	24V/INT	KM2	TERM.	A1
AP60.RV4	TERM.	8	INT	KM4	TERM.	A1
AP60.V1	TERM.	5		PT	TERM.	N
AP60RV4	TERM.	3	0V/BC	FS1	TERM.	8
KM4	TERM.	A2				
AP80.X32	BS-12	2	EN_DEV	XS20	BR-12	D
AP80.X32	BS-12	3	EN_DEV-N	XS20	BR-12	E
AP80.X32	BS-12	5	24V	XS20	BR-12	G
AP80.X32	BS-12	8	0V	XS20	BR-12	F
AP80.X32	BS-12	11	PDI	XS20	BR-12	A
AP80.X32	BS-12	12	PDH-N	XS20	BR-12	B
AP80.X32	BS-12	1	ES1B	XS20	BR-12	K
AP80.X32	BS-12	4	ES2B	XS20	BR-12	H
AP80.X32	BS-12	6	ES2A	XS20	BR-12	M
AP80.X32	BS-12	9	ES1A	XS20	BR-12	L
AP80.X34	BS-24	9	24V	SA.3	TERM.	13
AP80.X35		14	ESTOP1	AP41.XS1	EDG-96	A16
XS3		A10				
AP80.X35	BS-12	8	ENDEV/-N	XS3	AMP64	B1
AP80.X35	BS-12	20	24V/SYS	XS3	AMP64	A3
AP80.X35	BS-12	21	0V	XS3	AMP64	B3
AP80.X35	BS-12	9	ASTOP2	XS3	AMP64	B4
AP80.X35	BS-12	3	ES1A	XS3	AMP64	A9
AP80.X35	BS-12	11	ASTOP 1	XS3	AMP64	A4
AP80.X35	BS-12	15	LIMIT 2	XS18	BS18	9
AP80.X35	BS-12	4	ES2A	XS3	AMP64	B9
AP80.X35	BS-12	1	ES1C	XS3	AMP64	A8
AP80.X35	BS-12	2	ES2C	XS3	AMP64	B8
AP80.X35	BS-12	14	ESTOP1	XS3	AMP64	A10
AP80.X35	BS-12	15	LIMIT2	AP41.XS1	EDG-96	C16
AP80.X35	BS-24	23	ENDEV B	XS3	AMP64	A1
AP9.XS1	DR-15	4	ENABL/DRIV7A	XS22	BSK18	6
D1.1	BS-9	2	EXT/MODCOM1	XS17	BS-9	8
D1.1	FIL-4	1	0V	AP80.X22	BS-2	1

Cable, M94A (Cont)

From Connector	Type	PIN	Description	To Connector	Type	PIN
FREE END EV3			+24V	FREE END EV5		+
FREE END EV3			0V	FREE END EV5		-
FREE END R3				FREE END AP9.XS1		
FREE END R3				FREE END AP9.XS1		
FREE END R3				FREE END AP9.XS1		
FREE END R3				FREE END AP9.XS1		
FS1	TERM.		240V/L11	KM1	TERM.	2
FS1	TERM.		240V/L21	KM1	TERM.	4
FS1	TERM.		240V/L31	KM1	TERM.	6
FS1	TERM.	7	0V/INT	GS1.XS1	P-48	Z30
GS1.XS1	P-48	Z18	+24V/INT	PT	TERM.	+
GS1.XS1	P-48	Z28	0V/INT	PT	TERM.	-
GS1.XS1	P-48	D24	0V/INT	XS18	BS18	10
GS1.XS1	P-48	D16	BRAKE/PB	XS18	BS18	7
GS1.XS1	P-48	D26	0V/INT	XS18	BS18	12
*			0V/INT	XS18	BS18	11
GS1.XS1	P-48	B22	OVPTCM7A	XS22	BSK18	13
*			BRAKE/0V M7A	XS22	BSK18	13
GS1.XS1	P-48	B14	+24V / I/O	XS3	AMP64	A15
*			+24V / I/O	XS3		B15
*			+24V / I/O	XS3		A16
*			+24V / I/O	XS3		B16
*			+24V / I/O	XS3		C16
GS1.XS1	P-48	B24	0V	XS3	AMP64	C15
GS1.XS1	P-48	Z22	0V	KM1	TERM.	A16
GS1.XS1	P-48	D14	+5V	AP80.X22	BS-2	2
GS1.XS1	P-48	B16		XP18	BS18	8
GS1.XS1	P-48	B26		FREE END		
GS1.XS1	P-48	D10	EARTH	PE	TERM.	
KM1		3	INT	KM2	TERM.	3
KM1	TERM.	1	L11	KM2	TERM.	1
KM1	TERM.	3	L21	KM2	TERM.	3
KM1	TERM.	5	L31	KM2	TERM.	5
KM1	TERM.	7	24V/INT	GS1.XS1	P-48	D18
KM1	TERM.	21	24V/INT	KM1	TERM.	7
KM1	TERM.	12	INT	KM2	TERM.	1
KM2		43	CHAIN2	KM3	TERM.	43
AP41.XP1		C29				
KM2		8	MON	KM4	TERM.	3
KM2		12	INT	KM2	TERM.	22
KM2	TERM.	2	240V/L12	AP9.XS1	DR-15	22
KM2	TERM.	2	240V/L12	AP9.XS1	DR-15	24
KM2	TERM.	4	240V/L22	AP9.XS1	DR-15	26
KM2	TERM.	4	240V/L22	AP9.XS1	DR-15	28
KM2	TERM.	6	240V/L32	AP9.XS1	DR-15	30
KM2	TERM.	6	240V/L32	AP9.XS1	DR-15	32
KM2	TERM.	A1	24V/INT	TM1.XT1	TERM.	90
KM2	TERM.	11	24V/INT	KM2	TERM.	21
KM2	TERM.	33	EXT/MON2A	XS3	AMP64	B13
KM2	TERM.	34	EXT/MON2B	XS3	AMP64	B14
KM2	TERM.	8	INT	KM1	TERM.	22
KM3		54	STBY/HOLD2	KM3	TERM.	A2
AP60.V3		9				
XS3		D1				

Cable, M94A (Cont)

From Connector	Type	PIN	Description	To Connector	Type	PIN
KM3	TERM.	14	24V/INT	KM1	TERM.	21
KM3		33	CHAIN1	KM1	TERM.	43
KM3	TERM.	21	INT	KM4	TERM.	3
KM3	TERM.	44	INT	KM2	TERM.	3
KM3	TERM.	34	INT	KM1	TERM.	44
KM3	TERM.	14	INT	KM1	TERM.	12
KM3	TERM.	13	24V/ENABLE	XS22	BSK18	11
KM3	TERM.	A2	EARTH	PE	TERM.	
KM3	TERM.	A1	STBY/HOLD1B	KM3	TERM.	53
KM4	TERM.	6	B. REL/M7A	XS22	BSK18	12
KM4	TERM.	52	BRAKE/PBM7A	XS22	BSK18	12
KM4	TERM.	A2	0V/BC	AP60.RV4	TERM.	3
KM4	TERM.	1	EXT/BRAKEA	XS3	AMP64	C10
KM4	TERM.	2	EXT/BRAKEB	XS3	AMP64	C11
KM4	TERM.	51	STGY2/HOLD1B	KM3	TERM.	A1
SA.1	TERM.	10	MSTOP2	AP80.X34	BS-24	6
SA.1	TERM.	6	ASTOP2	AP80.X34	BS-24	12
SA.1	TERM.	8	MSTOP1	AP80.X34	BS-24	11
SA.1	TERM.	2	ASTOP1	AP80.X34	BS-24	10
SA.1	TERM.	5	GSTOP2A	AP80.X34	BS-24	8
SA.1	TERM.	1	GSTOP1A	AP80.X34	BS-24	7
SA.1	TERM.	18	MAN FS	AP80.X34	BS-24	20
SA.1	TERM.	16	MAN	AP80.X34	BS-24	19
SA.1	TERM.	14	AUTO	AP80.X34	BS-24	18
SA.1	TERM.	13	24V	AP80.X34	BS-24	24
SA.1	TERM.	20	AUTO 1	XP17	BS-9	1
SA.1	TERM.	22	MAN 1	XP17	BS-9	2
SA.1	TERM.	24	MANFS1	XP17	BS-9	3
SA.1	TERM.	26	AUTO 2	XP17	BS-9	4
SA.1	TERM.	28	MAN 2	XP17	BS-9	5
SA.1	TERM.	32	MANFS2	XP17	BS-9	6
SA.1	TERM.	25	MODECO2	XP17	BS-9	7
SA.1	TERM.	19	MODECO1	XP17	BS-9	8
SA.2	TERM.	X1	RUNLAMP	AP80.X34	BS-24	21
SA.2	TERM.	23	ESTOP2	AP80.X34	BS-24	16
SA.2	TERM.	24	LIM 2	AP80.X34	BS-24	14
SA.2	TERM.	13	ESTOP1	AP80.X34	BS-24	15
SA.2	TERM.	14	RUN PB	AP80.X34	BS-24	13
SA.3	TERM.	14	PB	AP80.X34	BS-24	9
SA.3	TERM.	X1	LAMP	AP80.X34	BS-24	17
SA.3	TERM.	X2	0V	AP80.X34	BS-24	5
SA.4	TERM.	11	ES1B	AP80.X34	BS-24	23
SA.4	TERM.	12	ES1C	AP80.X34	BS-24	4
SA.4	TERM.	21	ES2C	AP80.X34	BS-24	3
SA.4	TERM.	22	ES2B	AP80.X34	BS-24	22
TM1	TERM.	70	+24V/BR PB	XP18	BS18	7
TM1.XT1	TERM.	71	220V/L33	GS1.XS1	P-48	D2
TM1.XT1	TERM.	91		KM2	TERM.	11
TMLXT1	TERM.	70	0V/N	GS1.XS1	P-48	D6
XP22	BSK18	7	LIMIT/1	XP22	BSK18	10
XP22	BSK18	8	LIMIT/2	XP22	BSK18	9
XP22	BSK18	2	PTC M7	XP22	BSK18	3

Cable, M94A (Cont)

From Connector	Type	PIN	Description	To Connector	Type	PIN
XS1	AMP64	A1	M1R	AP1.XS1	DR-10	1
XS1	AMP64	A2	M1R	AP1.XS1	DR-10	2
XS1	AMP64	A5	M1T	AP1.XS1	DR-10	5
XS1	AMP64	A6	M1T	AP1.XS1	DR-10	6
XS1	AMP64	D10	M1T	AP1.XS1	DR-10	10
XS1	AMP64	A7	M2R	AP2.XS1	DR-10	1
XS1	AMP64	A8	M2R	AP2.XS1	DR-10	2
XS1	AMP64	A9	M2S	AP2.XS1	DR-10	3
XS1	AMP64	A10	M2S	AP2.XS1	DR-10	4
XS1	AMP64	A11	M2T	AP2.XS1	DR-10	5
XS1	AMP64	A12	M2T	AP2.XS1	DR-10	6
XS1	AMP64	A13	M3R	AP3.XS1	DR-10	1
XS1	AMP64	A14	M3R	AP3.XS1	DR-10	2
XS1	AMP64	A15	M3S	AP3.XS1	DR-10	3
XS1	AMP64	A16	M3S	AP3.XS1	DR-10	4
XS1	AMP64	B1	M3T	AP3.XS1	DR-10	5
XS1	AMP64	B2	M3T	AP3.XS1	DR-10	6
XS1	AMP64	D11	M4R	FREE END		
XS1	AMP64	B3	M4R	FREE END		
XS1	AMP64	D12	M4S	FREE END		
XS1	AMP64	B4	M4S	FREE END		
XS1	AMP64	D13	M4T	FREE END		
XS1	AMP64	B5	M4T	FREE END		
XS1	AMP64	D14	M5R	FREE END		
XS1	AMP64	B6	M5R	FREE END		
XS1	AMP64	D15	M5S	FREE END		
XS1	AMP64	B7	M5S	FREE END		
XS1	AMP64	D16	M5T	FREE END		
XS1	AMP64	B8	M5T	FREE END		
XS1	AMP64	B9	M6R	FREE END		
XS1	AMP64	B10	M5S	FREE END		
XS1	AMP64	B11	M6T	FREE END		
XS1	AMP64	B12	BRAKE/REL MA	KM4	TERM.	4
XS1	AMP64	B13	BRAKE/REL MA	KM4	TERM.	4
XS1	AMP64	B14	0V INT	XP18	BS-18	12
XS1	AMP64	D1	EXT/LIM 2	Z2	TERM.	4
XS1	AMP64	D2	EXT/LIM 1	Z2	TERM.	2
XS1	AMP64	C1	0V INT	XP18	BS18	11
XS1	AMP64	C2	PTC M1	XP18	BS18	1
XS1	AMP64	B15	0V INT	XP18	BS18	10
XS1	AMP64	B16	BRAKE/BP	KM4	TERM.	52
XS1	AMP64	C13	M3R	AP3.XS1	DR-10	8
XS1	AMP64	C14	M3S	AP3.XS1	DR-10	9
XS1	AMP64	C15	M3T	AP3.XS1	DR-10	10
XS1	AMP64		GROUND			
XS1	AMP64	D3	LIM 2	AP60.V3	TERM.	4
XS1	AMP64	D4	LIM 1	XS22	BSK18	8
XS1	AMP64	PE	EARTH	PE	TERM.	
XS1	AMP64	A3	M1S	AP1.XS1	DR-10	3
XS1	AMP64	A4	M1S	AP1.XS1	DR-10	4
XS1	AMP64	D8	M1S	AP1.XS1	DR-10	9
XS18	BS-28	8	LIMIT1	AP41.XS1	EDG-96	C15
XS22	BSK18	9	LIMIT/1	XS22	BSK18	7
XS22	BSK18	10	LIMIT/1	XP18	BS18	9

Cable, M94A (Cont)

From Connector	Type	PIN	Description	To Connector	Type	PIN
XS3		C10	MOFF	KM4	TERM.	1
XS3	AMP64	D1	STBY/HOLD2	AP60.V3	TERM.	9
XS3	AMP64	A2	MSTOP/1	AP80.X35	BS-24	10
XS3	AMP64	B2	MSTOP/2	AP80.X35	BS-24	7
XS3	AMP64	B7	GSTOP2B	XS3	AMP64	B6
XS3	AMP64	A6	GSTOP1B	XS3	AMP64	A7
XS3	AMP64	A11	ESTOP1	XS3	AMP64	A10
XS3	AMP64	B10	ESTOP2	AP80.X35	BS-24	13
XS3	AMP64	C7	HOLD 1	AP41.XS1	EDG-96	A9
XS3	AMP64	C8	HOLD11	AP41.XS1	EDG-96	A7
XS3	AMP64	C9	HOLD12	AP41.XS1	EDG-96	A8
XS3	AMP64	D7	HOLD2	AP41.XS1	EDG-96	C9
XS3	AMP64	D8	HOLD21	AP41.XS1	EDG-96	C7
XS3	AMP64	D9	HOLD22	AP41.XS1	EDG-96	C8
XS3	AMP64	B5	GSTOP2A	AP41.XS5	EDG-96	5
XS3	AMP64	A5	GSTOP1A	AP41.XS5	EDG-96	6
XS3	AMP64	A7	GSTOP1	AP41.XS1	EDG-96	A15
XS3	AMP64	A13	EXT/MON1A	KM1	TERM.	33
XS3	AMP64	A14	EXT/MON1B	KM1	TERM.	34
XS3	AMP64	C1	HOLD 1A	KM4	TERM.	1
XS3	AMP64	C2	HOLD 1B	KM3	TERM.	3
XS3	AMP64	C4	INT	XS17	BS-9	8
XS3	AMP64	C5	EXT/AUTO 1	XS17	BS-9	1
XS3	AMP64	C6	EXT/MAN 1	XS17	BS-9	2
XS3	AMP64	D4	EXT/MAN FS1	XS17	BS-9	3
XS3	AMP64	D5	EXT/AUTO 2	XS17	BS-9	4
XS3	AMP64	D6	EXT/MAN 2	XS17	BS-9	5
XS3	AMP64	D3	EXT/MAN FS2	XS17	BS-9	6
XS3	AMP64	C3	EXT/MODCOM2	XS17	BS-9	7
XS3	AMP64	PE	EARTH	PE	TERM.	
Z2	TERM.	1	EXT/LIM1	XS3	AMP64	A12
Z2	TERM.	3	EXT/LIM2	XS3	AMP64	B12

C21. Cable, M94A Control Wiring X-Reference

From Connector	Type	PIN	Description	To Connector	Type	PIN
AP1.XS1	DR-10	1	M1R	XS1	AMP64	A1
AP1.XS1	DR-10	2	M1R	XS1	AMP64	A2
AP1.XS1	DR-10	5	M1T	XS1	AMP64	A5
AP1.XS1	DR-10	6	M1T	XS1	AMP64	A6
AP1.XS1	DR-10	9	M1S	XS1	AMP64	D8
AP1.XS1	DR-10	10	M1T	XS1	AMP64	D10
AP2.XS1	DR-10	1	M2R	XS1	AMP64	A7
AP2.XS1	DR-10	2	M2R	XS1	AMP64	A8
AP2.XS1	DR-10	3	M2S	XS1	AMP64	A9
AP2.XS1	DR-10	4	M2S	XS1	AMP64	A10
AP2.XS1	DR-10	5	M2T	XS1	AMP64	A11
AP2.XS1	DR-10	6	M2T	XS1	AMP64	A12
AP3.XS1	DR-10	1	M3R	XS1	AMP64	A13
AP3.XS1	DR-10	2	M3R	XS1	AMP64	A14
AP3.XS1	DR-10	3	M3S	XS1	AMP64	A15
AP3.XS1	DR-10	4	M3S	XS1	AMP64	A16
AP3.XS1	DR-10	5	M3T	XS1	AMP64	B1
AP3.XS1	DR-10	6	M3T	XS1	AMP64	B2
AP3.XS1	DR-10	8	M3R	XS1	AMP64	C13
AP3.XS1	DR-10	9	M3S	XS1	AMP64	C14
AP3.XS1	DR-10	10	M3T	XS1	AMP64	C15
XS20	BR-12	D	EN_DEV	AP80.XS20	BS-12	2
XS20	BR-12	E	EN_DEV-N	AP80.XS20	BS-12	3
XS20	BR-12	G	24V	AP80.XS20	BS-12	5
XS20	BR-12	F	0V	AP80.XS20	BS-12	8
XS20	BR-12	A	PD1	AP80.XS20	BS-12	11
XS20	BR-12	B	PD1-N	AP80.XS20	BS-12	12
XS20	BR-12	K	ES1B	AP80.XS20	BS-12	1
XS20	BR-12	H	ES2B	AP80.XS20	BS-12	4
XS20	BR-12	M	ES2A	AP80.XS20	BS-12	6
XS20	BR-12	L	ES1A	AP80.XS20	BS-12	9
AP41.XS1	EDG-96	A15	GSTOP1	XS3	AMP64	A7
AP41.XS1	EDG-96	A16	ESTOP1	AP80.X35		14
AP41.XS1	EDG-96	A7	HOLD11	XS3	AMP64	C8
AP41.XS1	EDG-96	A8	HOLD12	XS3	AMP64	C9
AP41.XS1	EDG-96	A9	HOLD 1	XS3	AMP64	C7
AP41.XS1	EDG-96	C15	LIMIT1	XS18	BS-28	8
AP41.XS1	EDG-	C16	LIMIT2	AP80.X35	BS-12	15
AP41.XS1	EDG-96	C7	HOLD21	XS3	AMP64	D8
AP41.XS1	EDG-96	C8	HOLD22	XS3	AMP64	D9
AP41.XS1	EDG-96	C9	HOLD2	XS3	AMP64	D7
AP41.XS5	EDG-96	5	GSTOP2A	XS3	AMP64	B5
AP41.XS5	EDG-96	6	GSTOP1A	XS3	AMP64	A5
AP60.RV4	TERM.	3	0V/BC	KM4	TERM.	A2
AP60.V3	TERM.	4	LIM 2	XS1	AMP64	D3
AP60.V3	TERM.	9	STBY/HOLD2	XS3	AMP64	D1
AP80.X22	BS-2	1	0V	D1.1	FIL-4	1
AP80.X22	BS-2	2	+5V	GS1.XS1	P-48	D14

Cable, M94A Control Wiring X-Reference (Cont)

From Connector	Type	PIN	Description	To Connector	Type	PIN
AP80.X34	BS-24	3	ES2C	SA.4	TERM.	21
AP80.X34	BS-24	4	ES1C	SA.4	TERM.	12
AP80.X34	BS-24	7	GSTOP1A	SA.1	TERM.	1
AP80.X34	BS-24	8	GSTOP2A	SA.1	TERM.	5
AP80.X34	BS-24	9	PB	SA.3	TERM.	14
AP80.X34	BS-24	10	ASTOP1	SA.1	TERM.	2
AP80.X34	BS-24	12	ASTOP2	SA.1	TERM.	6
AP80.X34	BS-24	13	RUN PB	SA.2	TERM.	14
AP80.X34	BS-24	14	LIM 2	SA.2	TERM.	24
AP80.X34	BS-24	15	ESTOP1	SA.2	TERM.	13
AP80.X34	BS-24	16	ESTOP2	SA.2	TERM.	23
AP80.X34	BS-24	17	LAMP	SA.3	TERM.	X1
AP80.X34	BS-24	18	AUTO	SA.1	TERM.	14
AP80.X34	BS-24	19	MAN	SA.1	TERM.	16
AP80.X34	BS-24	20	MAN FS	SA.1	TERM.	18
AP80.X34	BS-24	21	RUNLAMP	SA.2	TERM.	X1
AP80.X34	BS-24	22	ES2B	SA.4	TERM.	22
AP80.X34	BS-24	23	ES1B	SA.4	TERM.	11
AP80.X34	BS-24	24	24V	SA.1	TERM.	13
AP80.X34	BS-24	11	MSTOP1	SA.1	TERM.	8
AP80.X34	BS-24	6	MSTOP2	SA.1	TERM.	10
AP80.X34	BS-24	5	0V	SA.3	TERM.	X2
AP80.X35	BS-24	7	MSTOP/2	XS3	AMP64	B2
AP80.X35	BS-24	10	MSTOP/1	XS3	AMP64	A2
AP80.X35	BS-24	17	MAN/FS	AP41.XS1	EDG96	C11
AP80.X35	BS-24	18	MAN	AP41.XS1	EDG96	C12
AP80.X35	BS-24	19	AUTO	AP41.XS1	EDG96	C10
AP80.X35	BS-24	24	ENDEV	AP41.XS1	EDG96	A12
AP80.X35	BS-24	13	ESTOP2	XS3	AMP64	B10
AP9.XS1	DR-15	22	240V/L12	KM2	TERM.	2
AP9.XS1	DR-15	24	240V/L12	KM2	TERM.	2
AP9.XS1	DR-15	26	240V/L22	KM2	TERM.	4
AP9.XS1	DR-15	28	240V/L22	KM2	TERM.	4
AP9.XS1	DR-15	30	240V/L32	KM2	TERM.	6
AP9.XS1	DR-15	32	240V/L32	KM2	TERM.	6
FREE END				GS1.XS1	P-48	B26
FREE END			M4R	XS1	AMP64	D11
FREE END			M4R	XS1	AMP64	B3
FREE END			M4S	XS1	AMP64	D12
FREE END			M4S	XS1	AMP64	B4
FREE END			M4T	XS1	AMP64	D13
FREE END			M4T	XS1	AMP64	B5
FREE END			M5R	XS1	AMP64	D14
FREE END			M5R	XS1	AMP64	B6
FREE END			M5S	XS1	AMP64	D15
FREE END			M5S	XS1	AMP64	B7
FREE END			M5T	XS1	AMP64	D16
FREE END			M5T	XS1	AMP64	B8
FREE END			M6R	XS1	AMP64	B9
FREE END			M5S	XS1	AMP64	B10
FREE END			M6T	XS1	AMP64	B11

Cable, M94A Control Wiring X-Reference (Cont)

From Connector	Type	PIN	Description	To Connector	Type	PIN
FREE END AP9.XS1				FREE END R3		
FREE END AP9.XS1				FREE END R3		
FREE END AP9.XS1				FREE END R3		
FREE END AP9.XS1				FREE END R3		
FREE END EV5		+	+24V	FREE END EV3		
FREE END EV5		-	0V	FREE END EV3		
FS1	TERM.	8	0V/BC	AP60RV4	TERM.	3
GS1.XS1	P-48	D18	24V/INT	KM1	TERM.	7
GS1.XS1	P-48	D2	220V/L33	TM1.XT1	TERM.	71
GS1.XS1	P-48	D6	0V/N	TMI.XT1	TERM.	70
GS1.XS1	P-48	Z30	0V/INT	FS1	TERM.	7
KM1	TERM.	1	MOFF	AP41.XS1	EDG96	C23
KM1	TERM.	2	240V/L11	FS1	TERM.	
KM1	TERM.	4	240V/L21	FS1	TERM.	
KM1	TERM.	6	240V/L31	FS1	TERM.	
KM1	TERM.	7	24V/INT	KM1	TERM.	21
KM1	TERM.	12	INT	KM3	TERM.	14
KM1	TERM.	21	24V/INT	KM3	TERM. TERM.	1421
KM1	TERM.	22	INT	KM2	TERM.	8
KM1	TERM.	33	EXT/MON1A	XS3	AMP64	A13
KM1	TERM.	34	EXT/MON1B	XS3	AMP64	A14
KM1	TERM.	43	CHAIN1	KM3		33C28
KM1	TERM.	A1	0V	GS1.XS1	P-48	Z22
KM1	TERM.	44	INT	KM3	TERM.	34
KM2	TERM.	1	L11	KM1	TERM.	1
KM2	TERM.	1	INT	KM1	TERM.	12
KM2	TERM.	3	INT	KM1		3
KM2	TERM.	3	L21	KM1	TERM.	3
KM2	TERM.	3	INT	KM3	TERM.	44
KM2	TERM.	5	L31	KM1	TERM.	5
KM2	TERM.	7	MON	AP41.XS1	EDG96	A23
KM2	TERM.	11		TM1.XT1	TERM.	91
KM2	TERM.	21	24V/INT	KM2	TERM.	11
KM2	TERM.	22	INT	KM2		12
KM2	TERM.	43	CHAIN2	AP41.XS1	EDG96	C29
KM2	TERM.	A1	24V/INT	AP60.RV2	TERM.	2
KM2	TERM.	A2		AP60.RV2	TERM.	7
KM3	TERM.	3	HOLD 1B	XS3	AMP64	C2
KM3	TERM.	22	BRAKE/REL	AP41.XS1	EDG96	C30
KM3	TERM.	33	CHAIN1	AP41.XS1	EDG96	C28
KM3	TERM.	43	CHAIN2	KM2		43
KM3	TERM.	53	STBY/HOLD1B	KM3	TERM.	A1
KM3	TERM.	54	0V	AP60.RV1	TERM.	6
KM3	TERM.	A1	STGY2/HOLD1B	KM4	TERM.	51
KM3	TERM.	A2	STBY/HOLD2	KM3		54
KM4	TERM.	1	MOFF	XS3		C10
KM4	TERM.	1	HOLD 1A	XS3	AMP64	C1
KM4	TERM.	3	MON	KM2		8
KM4	TERM.	3	INT	KM3	TERM.	21
KM4	TERM.	4	BRAKE/REL MA	XS1	AMP64	B12
KM4	TERM.	4	BRAKE/REL MA	XS1	AMP64	B13
KM4	TERM.	52	BRAKE/BP	XS1	AMP64	B16
KM4	TERM.	A1	INT	AP60.RV4	TERM.	8

Cable, M94A Control Wiring X-Reference (Cont)

From Connector	Type	PIN	Description	To Connector	Type	PIN
PE	TERM.		EARTH	GS1.XS1	P-48	D10
PE	TERM.		EARTH	KM3	TERM.	A2
PE	TERM.		EARTH	XS1	AMP64	PE
PE	TERM.		EARTH	XS3	AMP64	PE
PT	TERM.	+	+24V/INT	GS1.XS1	P-48	Z18
PT	TERM.	-	0V/INT	GS1.XS1	P-48	Z28
PT	TERM.	N		AP60.V1	TERM.	5
SA.3	TERM.	13	24V	AP80.X34	BS-24	9
TM1.XT1	TERM.	90	24V/INT	KM2	TERM.	A1
XP17	BS-9	1	AUTO 1	SA.1	TERM.	20
XP17	BS-9	2	MAN 1	SA.1	TERM.	22
XP17	BS-9	3	MANFS1	SA.1	TERM.	24
XP17	BS-9	4	AUTO 2	SA.1	TERM.	26
XP17	BS-9	5	MAN 2	SA.1	TERM.	28
XP17	BS-9	6	MANFS2	SA.1	TERM.	32
XP17	BS-9	7	MODECO2	SA.1	TERM.	25
XP17	BS-9	8	MODECO1	SA.1	TERM.	19
XP18	BS18	1	PTC M1	XS1	AMP64	C2
XP18	BS18	7	+24V/BR PB	TM1	TERM.	70
XP18	BS18	8		GS1.XS1	P-48	B16
XP18	BS18	9	LIMIT/1	XS22	BSK18	10
XP18	BS18	10	0V INT	XS1	AMP64	B15
XP18	BS18	11	0V INT	XS1	AMP64	C1
XP18	BS-18	12	0V INT	XS1	AMP64	B14
XP22	BSK18	3	PTC M7	XP22	BSK18	2
XP22	BSK18	9	LIMIT/2	XP22	BSK18	8
XP22	BSK18	10	LIMIT/1	XP22	BSK18	7
XS17	BS-9	1	EXT/AUTO 1	XS3	AMP64	C5
XS17	BS-9	2	EXT/MAN 1	XS3	AMP64	C6
XS17	BS-9	3	EXT/MAN FS1	XS3	AMP64	D4
XS17	BS-9	4	EXT/AUTO 2	XS3	AMP64	D5
XS17	BS-9	5	EXT/MAN 2	XS3	AMP64	D6
XS17	BS-9	6	EXT/MAN FS2	XS3	AMP64	D3
XS17	BS-9	7	EXT/MODCOM2	XS3	AMP64	C3
XS17	BS-9	8	EXT/MODCOM1	D1.1	BS-9	2
XS17	BS-9	8	INT	XS3	AMP64	C4
XS18	BS18	1	PTC/M1	AP41.XS1	EDG96	A19
XS18	BS18	7	BRAKE/PB	GS1.XS1	P-48	D16
XS18	BS18	9	LIMIT 2	AP80.X35	BS-12	15
XS18	BS18	10	0V/INT	GS1.XS1	P-48	D24
XS18	BS18	12	0V/INT	GS1.XS1	P-48	D26
XS22	BSK18	6	ENABL/DRIV7A	AP9.XS1	DR-15	4
XS22	BSK18	7	LIMIT/1	XS22	BSK18	9
XS22	BSK18	8	LIM 1	XS1	AMP64	D4
XS22	BSK18	11	24V/ENABLE	KM3	TERM.	13
XS22	BSK18	12	B. REL/M7A	KM4	TERM.	6
XS22	BSK18	12	BRAKE/PBM7A	KM4	TERM.	52
XS22	BSK18	13	OVPTCM7A	GS1.XS1	P-48	B22

Cable, M94A Control Wiring X-Reference (Cont)

From Connector	Type	PIN	Description	To Connector	Type	PIN
XS3	AMP64	A1	ENDEV B	AP80.X35	BS-24	23
XS3	AMP64	A10	ESTOP1	AP80.X35	BS-12	14
XS3	AMP64	A10	ESTOP1	XS3	AMP64	A11
XS3	AMP64	A12	EXT/LIM1	Z2	TERM.	1
XS3	AMP64	A2	MSTOP1	AP41.XS1	EDG96	A14
XS3	AMP64	A3	24V/SYS	AP80.X35	BS-12	20
XS3	AMP64	A4	ASTOP1	AP41.XS1	EDG96	A13
XS3	AMP64	A4	ASTOP 1	AP80.X35	BS-12	11
XS3	AMP64	A7	GSTOP1B	XS3	AMP64	A6
XS3	AMP64	A8	ES1C	AP80.X35	BS-12	1
XS3	AMP64	A9	ES1A	AP80.X35	BS-12	3
XS3	AMP64	B1	ENDEV/-N	AP80.X35	BS-12	8
XS3	AMP64	B12	EXT/LIM2	Z2	TERM.	3
XS3	AMP64	B13	EXT/MON2A	KM2	TERM.	33
XS3	AMP64	B14	EXT/MON2B	KM2	TERM.	34
XS3	AMP64	B3	0V	AP80.X35	BS-12	21
XS3	AMP64	B4	ASTOP2	AP80.X35	BS-12	9
XS3	AMP64	B6	GSTOP2B	XS3	AMP64	B7
XS3	AMP64	B8	ES2C	AP80.X35	BS-12	2
XS3	AMP64	B9	ES2A	AP80.X35	BS-12	4
XS3	AMP64	C10	EXT/BRAKEA	KM4	TERM.	1
XS3	AMP64	C11	EXT/BRAKEB	KM4	TERM.	2
XS3	AMP64	C12	POWER/OK	AP41.XS1	EDG96	C22
XS3	AMP64	D10	SENS/1	AP41.XS1	EDG96	A1
XS3	AMP64	D11	SENS/2	AP41.XS1	EDG96	C1
XS3	AMP64	D12	SENS/3	AP41.XS1	EDG96	A2
XS3	AMP64	D13	0V/SENS	AP41.XS1	EDG96	C2
XS3	AMP64	A15	+24V / I/O	GS1.XS1	P-48	B14
XS3	AMP64	C15	0V	GS1.XS1	P-48	B24
Z2	TERM.	2	EXT/LIM 1	XS1	AMP64	D2
Z2	TERM.	4	EXT/LIM 2	XS1	AMP64	D1
			GROUND	XS1	AMP64	

C22. Connectors

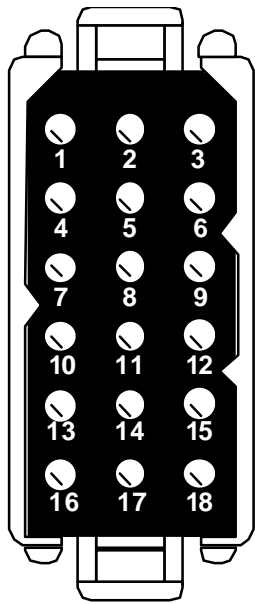

BS - 18

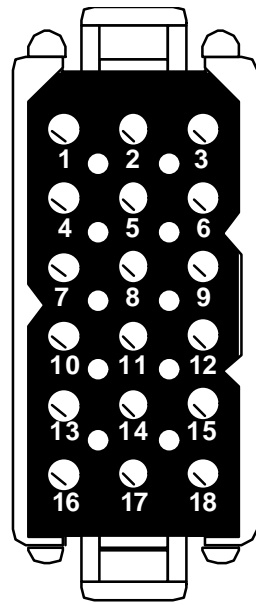

BSK - 18

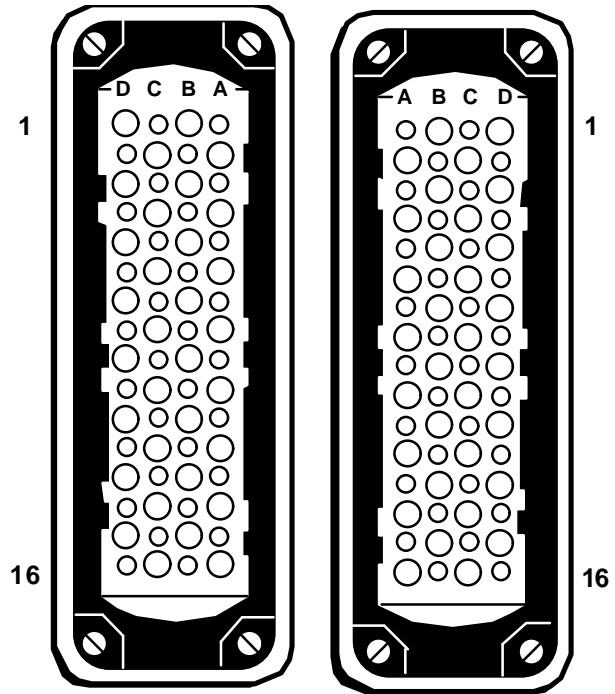

AMP - 64

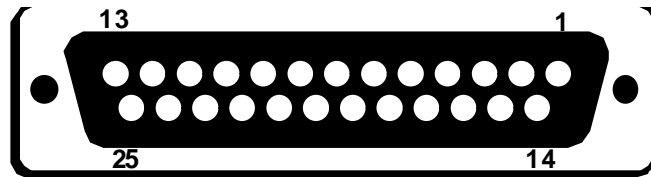

DB - 25

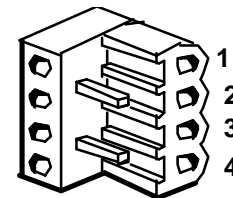

FIL - 4

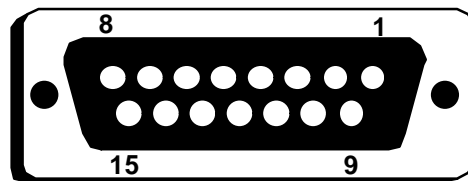

DB - 15

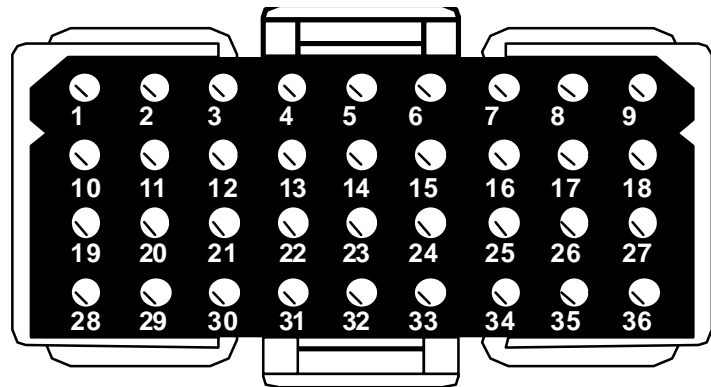

BS - 36

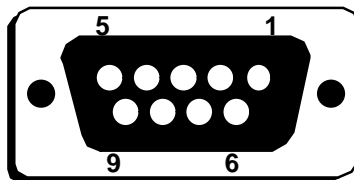

DB - 9

Connectors (Cont)

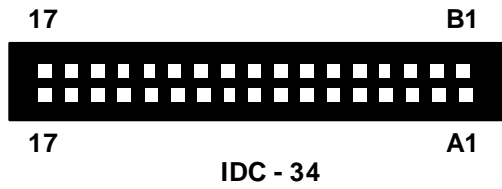
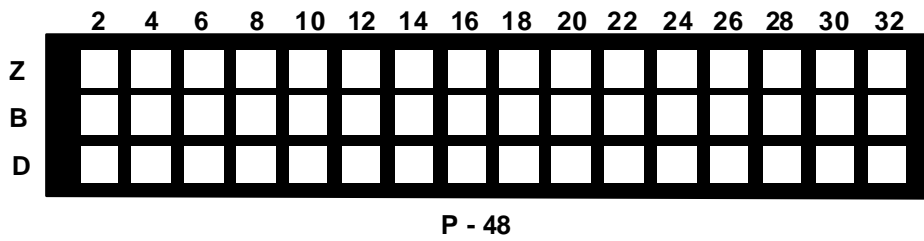
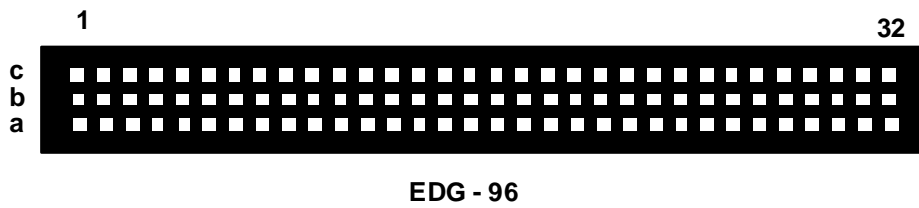
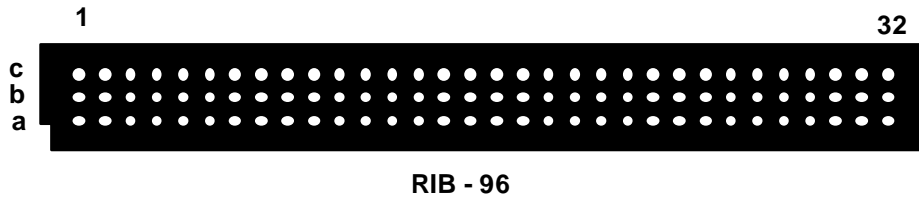

Connectors (Cont)



BR - 23

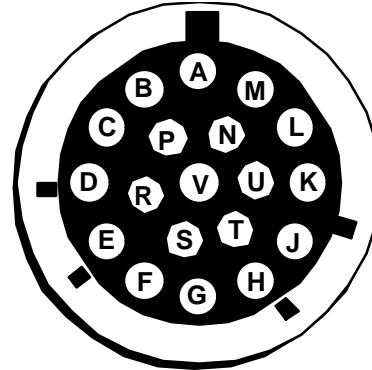

BR - 19

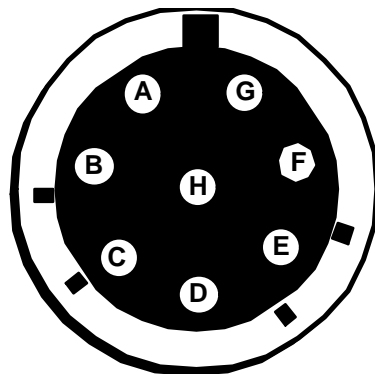

BR - 8

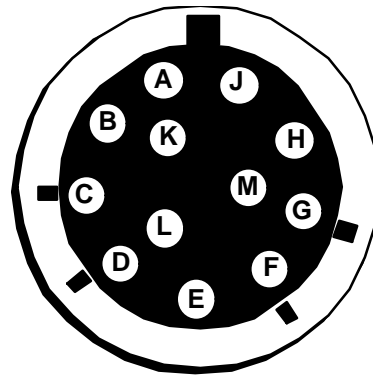

BR - 12

Connectors(Cont)

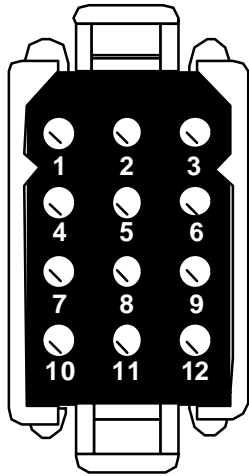

BS - 12

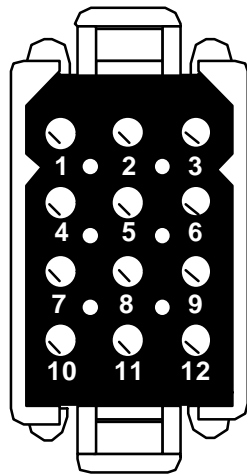

BSK - 12

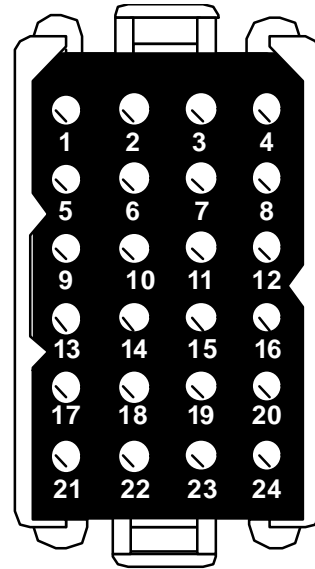

BS - 24

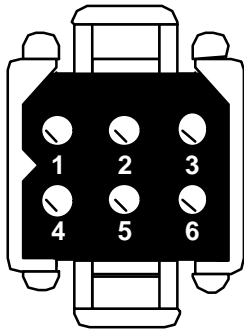

BS - 6

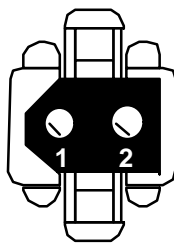

BS - 2

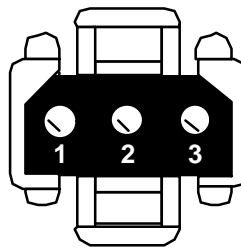

BS - 3

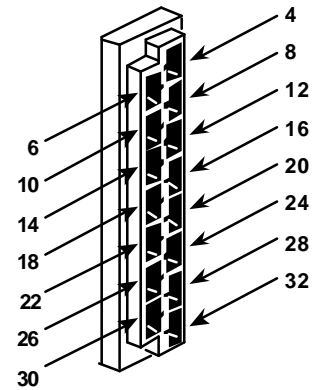

DR - 15

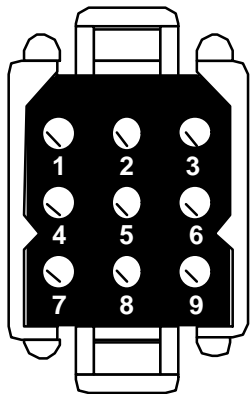

BS - 9

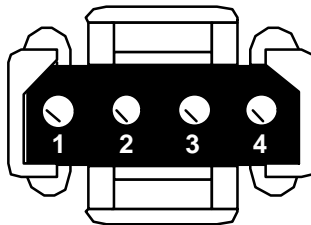

BS - 4

NOTES

NOTES

APPENDIX D

GLOSSARY

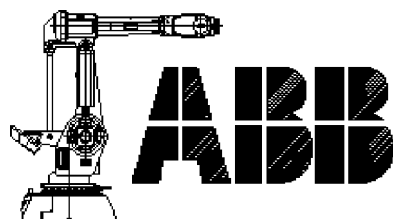

D. GLOSSARY

ACTUATOR:

A device which converts electrical, hydraulic, or pneumatic energy to effect motion of the robot.

APPLICATION PROGRAM:

The set of instructions that define the specific intended tasks of robots and robot systems. This program may be originated and modified by the robot user.

ARGUMENT

The parts of an instruction that can be changed, i.e., everything except the name of the instruction.

ATTENDED CONTINUOUS OPERATION:

The time when robots are performing production tasks at a speed no greater than slow speed through attended program execution.

ATTENDED PROGRAM VERIFICATION:

The time when a person within the restrictive envelope verifies the robot's programmed tasks at the programmed speed.

AUTOMATIC MODE:

The robot state in which automatic operation can be initiated.

AUTOMATIC OPERATION:

The time during which robots perform programmed task through unattended program execution.

AWARENESS BARRIER:

Physical and visual means that warns a person of an approaching or present hazard.

AWARENESS SIGNAL:

A device that by means of an audible sound or visible light warns a person of an approaching or present hazard.

BARRIER:

A physical means of separating persons from the restrictive envelope.

COMMUTATION:

Commutation is the process of aligning the motor shaft to the resolver for motor firing sequencing.

COMPONENT

One part of a record.

CONFIGURATION

The position of the robot axes at a particular location.

CONSTANT

Data that can only be changed manually.

CONTROL DEVICE:

Any piece of control hardware providing a means of human intervention into the control of a robot or robot system, such as an emergency-stop button, a start button, or a selector switch.

GLOSSARY(Cont)

CONTROL PROGRAM:

The inherent set of control instructions that define the capabilities, action, and responses of a robot system. This program is usually not intended to be modified by the user.

COORDINATE STRAIGHT LINE MOTION:

Control wherein the axis of the robot arrives at their respective end points simultaneously, giving a smooth appearance to the motion. Control wherein the motions of the axes are such that the tool center point moves along a pre-specified type of path (line, circle, or other.)

CORNER PATH

The path generated when passing a fly-by point.

DECLARATION

The part of a routine or data that defines its properties.

DEVICE:

Any piece of control hardware, such as an emergency stops button, a selector switch, a control pendant, a relay, a solenoid valve, or a sensor.

DIALOG/DIALOG BOX

Any dialog boxes appearing on the display of the teach pendant must always be terminated, usually by pressing OK or Cancel, before they can be exited.

DRIVE POWER

The energy source or sources for the robot actuators.

EMERGENCY STOP (E-STOP) - IEC 204-1,10.7

A condition which overrides all other robot controls, removes drive power from robot axis actuators, stops all moving parts and removes power from other dangerous functions controlled by the robot.

ENABLING DEVICE - ISO 11161, 3.4

A manually operated device which, when continuously activated in one position only, allows hazardous functions but does not initiate them. In any other position, hazardous functions can be stopped safely.

ENDEFFECTOR

An accessory device or tool especially designed for the attachment to the robot wrist or tooling mounting plate to enable the robot to perform its intended task.

ENERGY SOURCE

Any electrical, mechanical, hydraulic, pneumatic, chemical, thermal, potential, kinetic or other source.

ENVELOPE MAXIMUM

The volume of space encompassing the maximum designed movements of all robot parts including the end effector, workpiece and attachments.

ENVELOPE RESTRICTED

The portion of the maximum envelope to which the robot is restricted by limiting devices. The maximum distance the robot can travel after limiting devices are installed defines the boundaries of the restricted envelope of the robot.

GLOSSARY(Cont)**ENVELOPE OPERATING**

That portion of the restricted envelope that is actually used by the robot while performing its programmed motions.

ERROR HANDLER

A separate part of a routine where an error can be taken care of. Normal execution can then be restarted automatically.

EXPRESSION

A sequence of data and associated operands; e.g. reg1 + 5 or reg1 > 5.

FLY-BY POINT

A point which the robot only passes in the vicinity of, without stopping. The distance to that point depends on the size of the programmed zone.

FUNCTION

A routine that returns a value.

GALVANICALLY INSULATED

Protected from electrical noise.

GROUP OF SIGNALS

A number of digital signals that are grouped together and handled as one signal.

HAZARD

A situation that is likely to cause personal physical harm.

HAZARDOUS MOTION

Any motion that is likely to cause personal physical harm.

HOLD-TO-RUN CONTROL - ISO 10218 (EN 775), 3.2.7

A control which only allows movements during its manual actuation and which causes these movements to stop as soon as it is released.

INDUSTRIAL EQUIPMENT

Physical apparatus used to perform industrial tasks, such as welders, conveyors, machine tools, fork trucks, turn tables positioning tables or robots.

INDUSTRIAL ROBOT

A programmable multifunctional manipulator designed to move material, parts, tools, or specialized devices, through a variable programmed motions for the performance of a variety of tasks.

INTERLOCK (For Safeguarding) - ISO 10218 (EN 775), 3.2.8

A function that interconnects a guard(s) or a device and the robot controller and/or power system of the robot and its associated equipment. OR An arrangement whereby the operator of one control or mechanism allows, or prevents the operation of another.

INTERRUPT

An event that temporarily interrupts program execution and executes a trap routine.

GLOSSARY(Cont)

I/O

Electrical inputs and outputs.

JOINT MOTION

A method for coordinating the movement of the joints such that all joints arrive at the desired location simultaneously.

LIMITING DEVICE

A device that restricts the maximum envelope by stopping or causing to stop all robot motion and is independent of the control program and the application program.

MAIN ROUTINE

The routine that usually starts when the Start key is pressed.

MAINTENANCE

The act of keeping the robot and the robot system in their proper operating condition.

MANUAL MODE

The applicable mode when the operating mode is set to F.

MECHANICAL UNIT

A group of external axes.

MODULE

A group of routines and data, i.e. a part of the program.

MOTOR ON/OFF

The state of the robot, i.e. whether or not the power supply to the motors is switched on.

OPERATOR

The person designed to start, monitor, and stop the intended productive operation of a robot or robot system. An operator may also interface with the robot for the productive purposes.

OPERATOR'S PANEL

The panel located on the front of the control system.

OPTICALLY ISOLATED

A way to protect internal electronics from external electronics by running signals through light sensitive devices.

ORIENTATION

The direction of an end effector, for example.

PARAMETER

The input data of a routine, sent with the routine call. It corresponds to the argument of an instruction.

PENDANT

Any portable control device, including teach pendants, that permit an operator to control the robot within the restrictive envelope of the robot.

GLOSSARY(Cont)

PERIMETER GUARDING

A rigid fence like structure that surrounds the restrictive envelope of a system of one or more robots and may have entry openings for process equipment, material and/or authorized personnel who operate or maintain the robot system.

PERSISTENT

A variable, the value of which is persistent.

POSE

The planned motions that the robot is to execute.

PRESENCE-SENSING SAFEGUARD DEVICE

A device designed, constructed and installed to create a sensing field or area to detect an intrusion into such field or area by personal, robot, and other objects.

PROGRAM

Noun: A sequence of instructions to be executed by the computer or robot controller to control a robot/robot system.

Verb: To furnish a computer with a code of instructions.

Verb: To teach a robot system a specific set of movements and instructions to accomplish a task.

PROGRAM DATA

Data that can be accessed in a complete module or in the complete program.

PROGRAM MODULE

A module included in the robot's program and which is transferred when copying the program to a diskette, for example.

PROGRAM START KEY

A button that is pressed to start program execution.

PROCEDURE

A routine which, when called, can independently form an instruction.

REBUILD

To restore the robot to the original specifications of the manufacturer.

RECORD

A compound data type.

REDUCED SPEED - ISO 10218 (EN775), 3.2.17

A single, selectable velocity provided by the robot supplier which automatically restricts the robot velocity to that specified in order to allow sufficient time for people either to withdraw from the hazardous area or to stop the robot.

REPAIR

To restore robots and robot systems to operating condition after damage, malfunction, or wear.

ROUTINE

A subprogram.

GLOSSARY(Cont)

ROUTINE DATA

Local data that can only be used in a routine.

SAFEGUARD

A barrier guard, device or safety procedure designed for the protection of personnel.

SAFETY PROCEDURE

A set of instructions designed for the protection of personnel.

SAFETY STOP - ISP 10218 (EN 775), 6.4.3

When a safety stop circuit is provided, each robot must be delivered with the necessary connections for the safeguards and interlocks associated with this circuit. It is necessary to reset the power to the machine actuators before any robot motion can be initiated. However, if only the power to the machine actuators is reset, this should not suffice to initiate any operation.

SENSOR

A device that response to physical stimuli such as heat, light, sound, pressure, magnetism and motion.

SERVICE

To adjust, repair, maintain, and make fit for use.

SINGLE POINT OF CONTROL

The ability to operate the robot such that initiation of the robot motion from one source of control is only possible from the source and cannot be overwritten from another source.

SLOW SPEED CONTROL

A mode of robot motion control where the velocity of the robot is limited to allow persons sufficient time to either withdraw from the hazardous motion or stop the robot.

START-UP

Routine application of drive power to the robot/robot system.

START POINT

The instruction that will be executed first when starting program execution.

STOP POINT

A point at which the robot stops before it continues on to the next point.

SYSTEM MODULE

A module that is always present in the program memory. When a new program is read, the system modules remain in the program memory.

SYSTEM PARAMETERS

The settings which define the robot equipment and properties; configuration data in other words.

TEACH

The generation and storage of a series of positional data points effected by moving the robot arm through a path of intended motions.

GLOSSARY(Cont)

TEACHMODE

The control state that allows the generation and storage of positional data points effected by moving the robot arm through a path of intended motions.

TEACHPENDANT

The device used by the operator to interface with the controller. The operator can start and stop program execution, create/edit programs and perform all necessary operator input functions.

TEACHER

A person who provides the robot with a specific set of instructions to perform a task.

TOOL CENTER POINT (TCP)

The origins of the tool coordinate system. The position of the tooling activity position.

TRAPROUTINE

The routine that defines what is to be done when a specific interrupt occurs.

VARIABLE

Data that can be changed from within a program, but which loses its value (returns to its initial value) when a program is started from the beginning.

WINDOW

The robot is programmed and operated by means of a number of different windows, such as the Program window and the Service window. A window can always be exited by choosing another window.

ZONE

The spherical space that surrounds a fly-by point. As soon as the robot enters this zone it starts to move to the next position.

NOTES

APPENDIX E

CIRCUIT DIAGRAMS

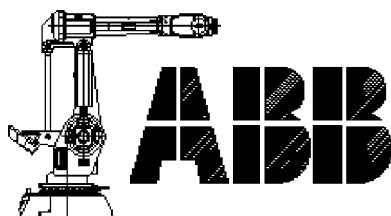

Circuit Diagrams

Table of Contents

E.	CIRCUIT DIAGRAMS	E-3
E1.	Sheet Numbering	E-3
E2.	Connector Labeling	E-4
E3.	Component Labeling	E-5
E4.	Sheet Referencing	E-6
E5.	Relay Labeling	E-7
E6.	Key Switch Contacts	E-8

NOTES

E. CIRCUIT DIAGRAMS

E1. Sheet Numbering

This chapter is used to help explain the symbology of the circuit diagrams used in this manual. The figure below shows how each page is identified by a block in the lower right hand corner of each sheet. Also shown below is where referencing numbers along the left side of each page are located. And that when a dashed box is seen on a page, that it is indicating a component or a connector that circuits are going through.

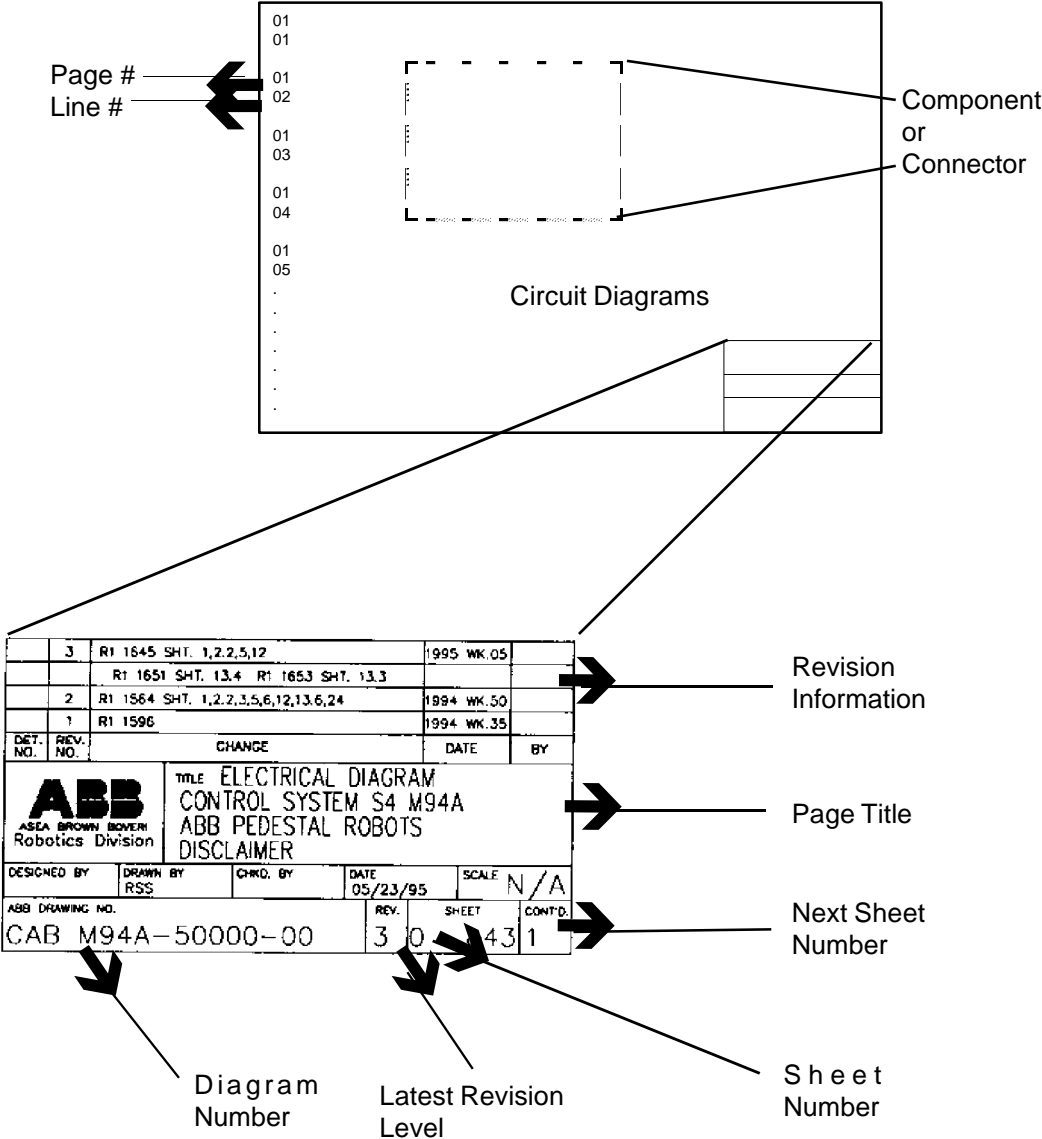

E2. Connector Labeling

Ribbon cables are sometimes used in the control cabinet and are designated as shown below. The connectors on the ends of the ribbon cable are typical to the way all connectors are labeled throughout the circuit diagrams.

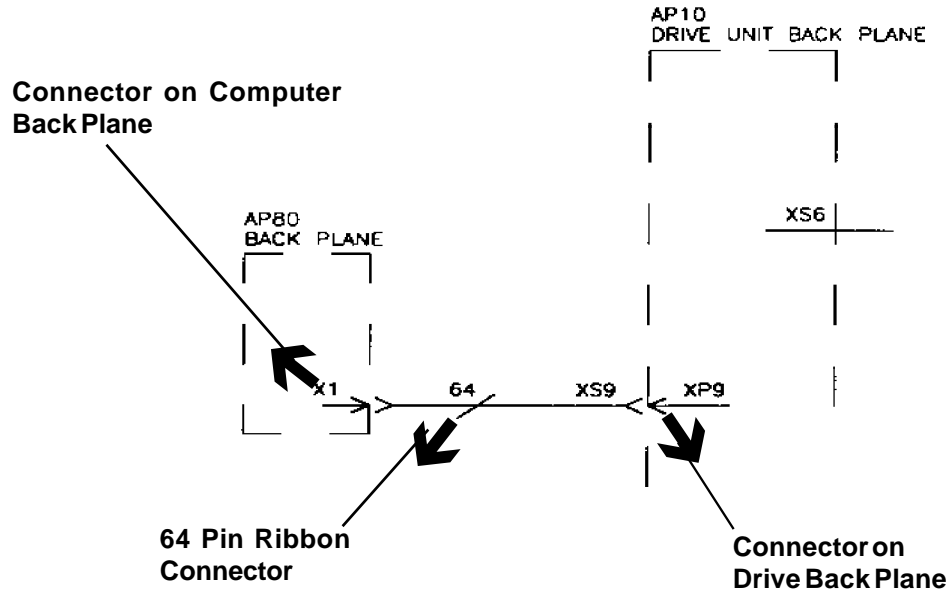

Abbreviations:

- AP** - Computer board connection
- EV** - Fans
- FS** - Automatic fuses, also known as circuit breakers
- FU** - Fuses
- KM** - Large relay on top of swing gate
- K** - Small relay on system board
- RV** - Noise suppression drive
- XT** - Terminal strip
- XS** - Socket side of a connector (female pin)
- XP** - Pin side of a connector (male pin)
- SA** - Switches "A"
- SB** - Switches "B"
- TM** - Transformer
- Z** - Noise suppression device

E3. Component Labeling

Component labeling is very important because there are no wire numbers in the controller or robot. Instead, every connector is clearly labeled so troubleshooting is accomplished by checking from connector point to connector point. In the circuit diagrams there are wire descriptions printed on wire lines for ease of following circuits from page to page.

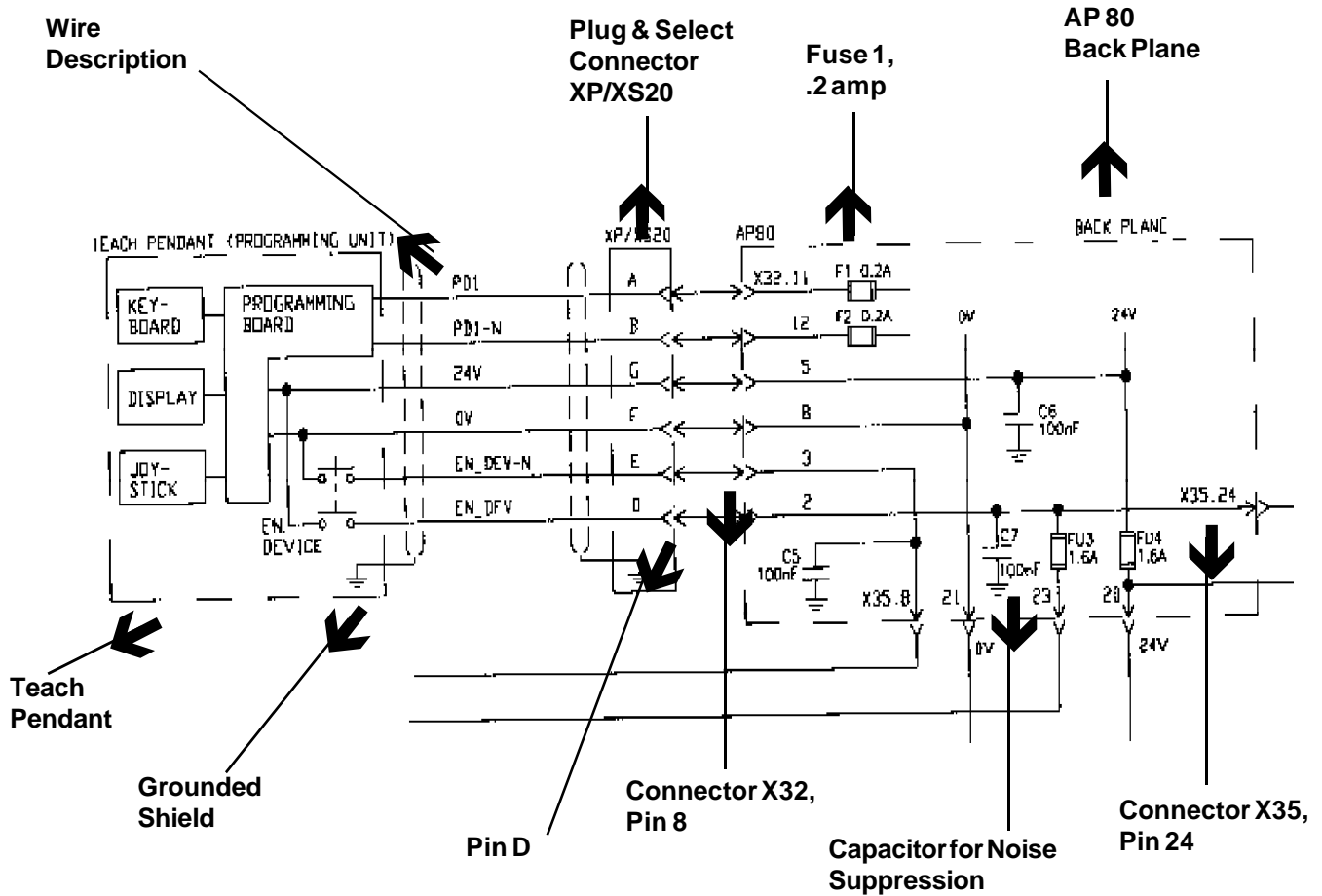

All components labeled with "X" followed by a number are a connector to a board (X32 is on Back Plane.)

- "XP" is a connector, **Pin** Side
- "XS" is a connector, **Socket** Side
- "XP's" connect to "XS's"

E4. Sheet Referencing

When the circuit diagram goes from one sheet to another, the wires are referenced using the page number plus an area number.

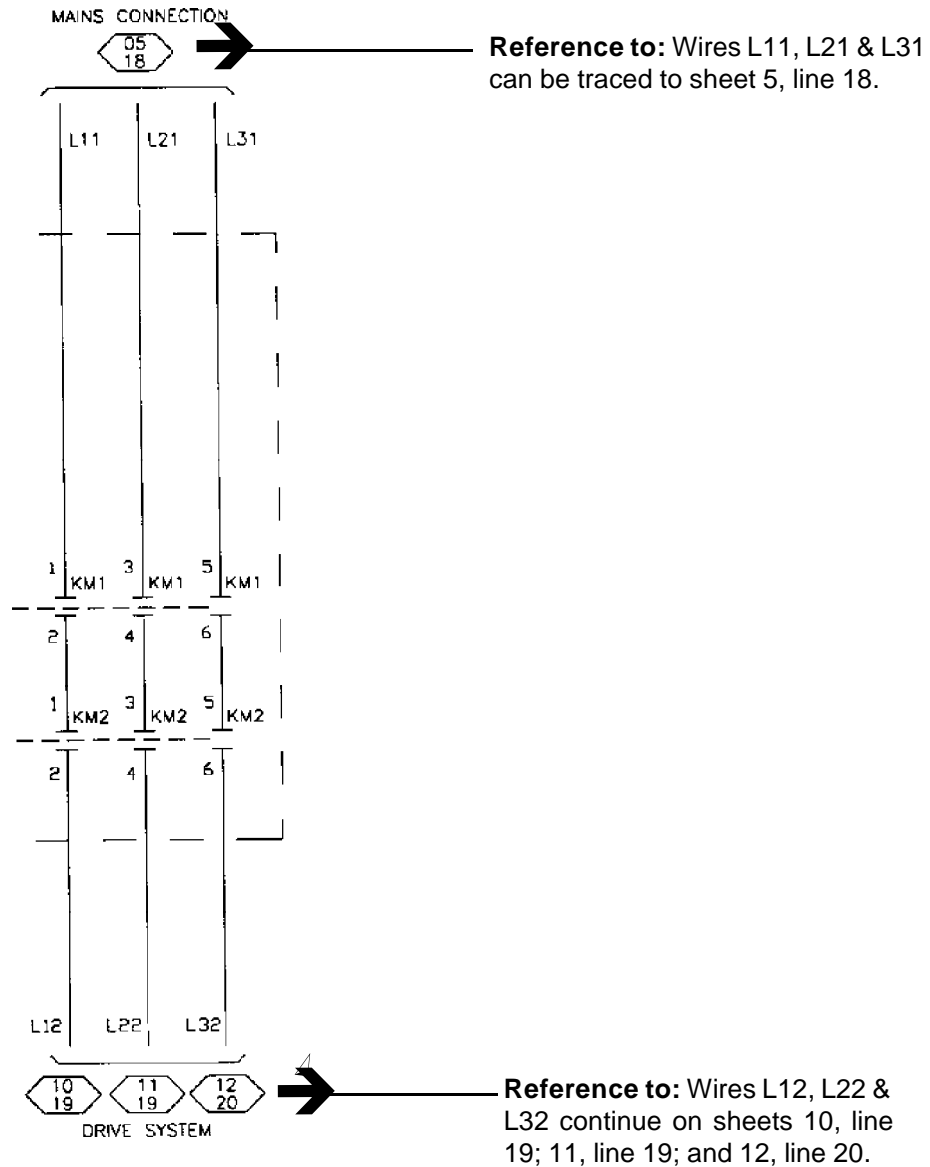

E5. Relay Labeling

The relays used in the robot are made by ABB. The labeling of these relays is shown below. When a relay terminal is described, (example: terminal 43) the two digit number is split into two separate level numbers. The first number (4) is for the lower level of the relay and the second number (3) is for the top level of the relay.

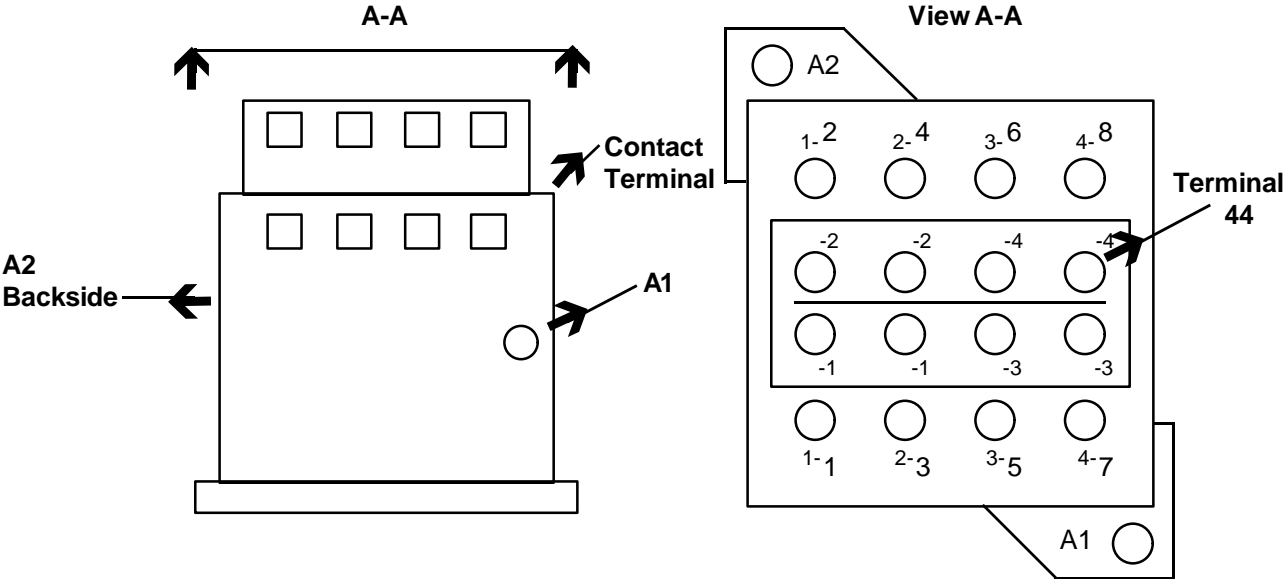
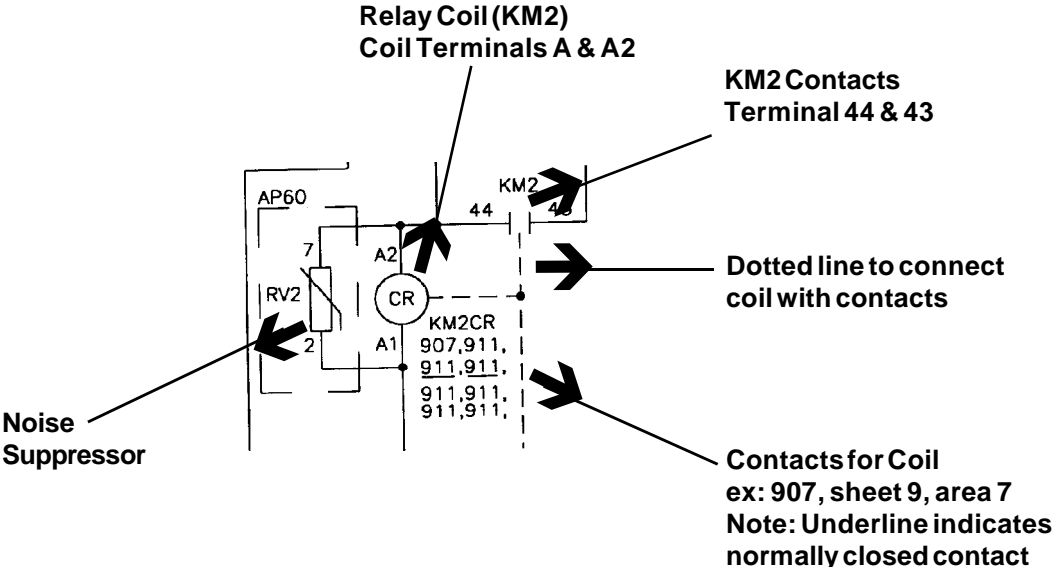

E6. Key Switch Contacts

There are five sets of contacts on the Mode Selector located on the front panel.

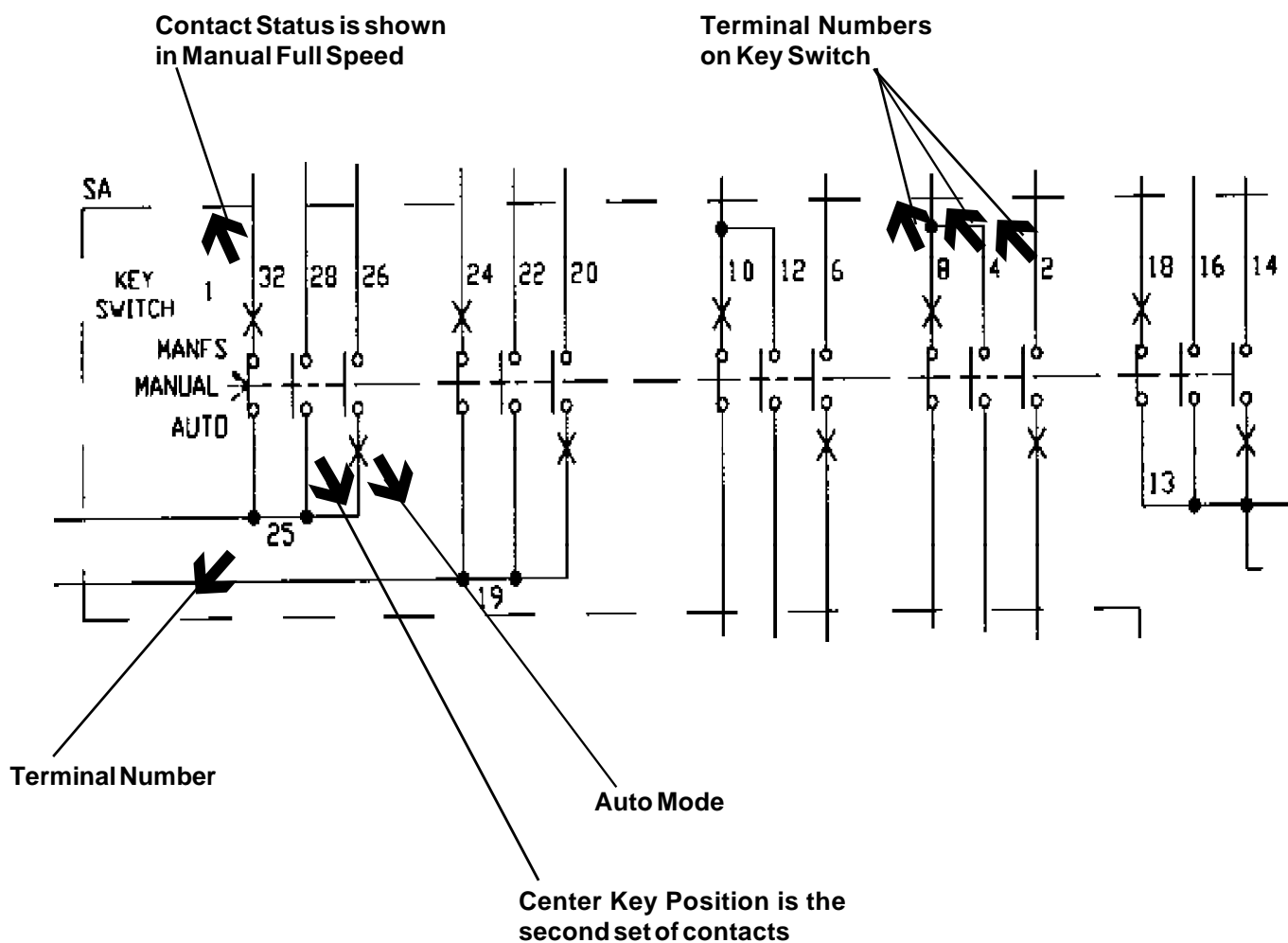

E7. Symbols and Abbreviations

The following are symbols and abbreviations used in the Manipulator Circuit Diagrams.

M Motor

B Brake

PTC Positive Temperature Coefficient

R Resolver

G Battery Pack

BU Brake Unit

FB Feed-back Unit

SMB Serial Measurement Board

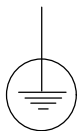

Earth Ground

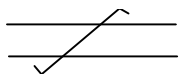

Twisted Cables

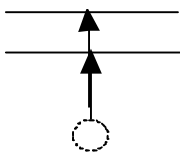

Screened Cables

NOTES

The information in this document is subject to change without notice and should not be construed as a commitment by ABB Robotics Products AB. ABB Robotics Products AB assumes no responsibility for any errors that may appear in this document.

In no event shall ABB Robotics Products AB be liable for incidental or consequential damages arising from use of this document or of the software and hardware described in this document.

This document and parts thereof must not be reproduced or copied without ABB Robotics Products AB's written permission, and the contents thereof must not be imparted to a third party nor be used for any unauthorized purpose. Contravention will be prosecuted.

Additional copies of this document may be obtained from ABB Robotics Products AB at its then current charge.

Preliminary Drawing
NOT CHECKED!
 DATE: 05/23/95
 ABB Flexible Automation

CONVERTED TO NORTH AMERICAN FORMAT
 FROM EUROPEAN DOCUMENT No. 3-M4B 2821-5

3	RS 1645 SHT. L2251E	1995 WK25
	RS 1651 SHT. 134 RS 1659 SHT. 133	
2	RS 1364 SHT. L2235A, L230A, 24	1994 WK26
1	RS 1396	1994 WK25
REV. NO.	CHANGE	DATE
 TITLE: ELECTRICAL DIAGRAM CONTROL SYSTEM S4 M94A ABB PEDESTAL ROBOTS DISCLAIMER		
DESIGNED BY	DRAWN BY	CHECKED BY
	RSB	
DATE	SCALE	CONF.
05/23/95	N/A	
ABB DRAWING NO.	REV.	SHEET
CAB M94A-50000-00	3 0	of 43 1

We reserve all rights in this document and in the information contained therein. Reproduction, use or disclosure in third parties without express authority is strictly forbidden.
 ABB 19

SHEET No.	OPTION No.	TITLE
1		DRAWING INDEX
2	111,112	VIEW OF CONTROL CABINET
3		DESIGNATION
4		BLOCK DIAGRAM
5	13X,14X,15X,432-433	MAINS CONNECTION
6	339	POWER SUPPLY
7		MOTOR ON CHAIN PART 1
8		MOTOR ON CHAIN PART 2
9		POWER UNIT
10		DRIVE SYSTEM IRB 1400
11		DRIVE SYSTEM IRB 1400H & 2400
12		DRIVE SYSTEM IRB 3400 & 6400
13.1		CONTROL CABLES
13.2	197	SERIAL MEASUREMENT BOARD, EXTERNAL AXES
13.3	191	INTEGRATED DRIVE UNIT, EXTERNAL AXIS

SHEET No.	OPTION No.	TITLE
13.4	32X	CONNECTIONS FOR ABB ESAB EQUIPMENT
13.5	65X	OPTIONAL CUSTOMER CONNECTIONS, MANIPULATOR
13.6	7X,8X,9X	OPTIONAL POSITION INDICATOR, MANIPULATOR
14	411-413	FLOPPY DISC UNIT, DATA PORTS, BATTERIES
15-17	193	EXTERNAL AXES BOARD
18		I/O BOARD POSITIONS
19.1-19.5	20X/23B	I/O BOARDS, DIGITAL INPUTS
20.1-20.6	20X/23B	I/O BOARD, DIGITAL OUTPUTS
21.1-21.2	23B	ANALOGUE OUTPUT PART OF COMBI I/O BOARD
22	227	ANALOGUE I/O BOARD
23	241	REMOTE I/O BOARD
24	406,421-425,439,444	ILLUMINATION, SERVICE OUTLET, COOLING DEVICE
25	5X	OPTIONAL FAN, AXIS 1 MANIPULATOR
26	182	EXTERNAL CONTROL PANEL

Preliminary Drawing

DATE: 05/23/95

ABB Flexible Automation

CONVERTED TO NORTH AMERICAN FORMAT
FROM EUROPEAN DOCUMENT No. 3HAB 2821-5

3	RI 1645		3995	UK:05
2	RI 1564		3994	UK:00
DET. NO.	REV. NO.	CHANGE	DATE	BY
		TITLE ELECTRICAL DIAGRAM CONTROL SYSTEM S4 M94A ABB PEDESTAL ROBOTS DRAWING INDEX		
DESIGNED BY	DRAWN BY	CHECK BY	DATE	SCALE
	RSS		05/23/95	N/A
ABB DRAWING NO.		REV.	SHEET	CONTR.
CAB M94A-50001-00		3	1	of 43 2.1

We reserve all rights in this document and in the information contained therein. Reproduction, use or disclosure to third parties without express authority is strictly forbidden.
ABB 19

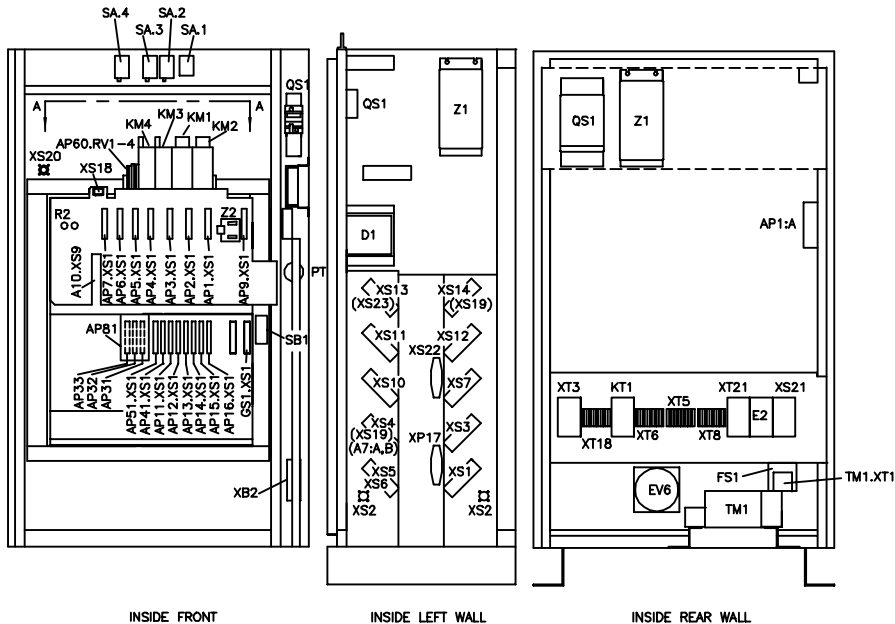
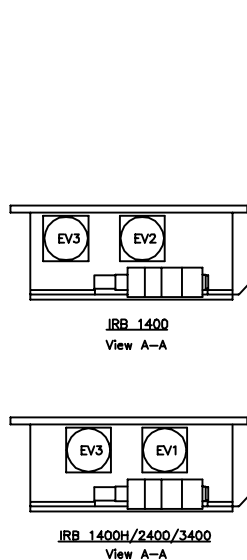

CABINET LAYOUT, SMALL SIZE (OPTION 111)

Preliminary Drawing

DATE: 05/23/95
ABB Flexible Automation

CONVERTED TO NORTH AMERICAN FORMAT
FROM EUROPEAN DOCUMENT No. 3HAB 2821-5

We reserve all rights in this document and in the information contained therein. Reproduction, use or disclosure to third parties without express authority is strictly forbidden.
ABB 19

DET. NO.	REV. NO.	CHANGE	DATE	BY

ABB
ABB Inverter Systems
Robotics Division

TITLE: ELECTRICAL DIAGRAM
CONTROL SYSTEM S4 M94A
ABB PEDESTAL ROBOTS
CAB. LAYOUT, SM. SIZE (OPT. 111)

DESIGNED BY	DRAWN BY	CHECK BY	DATE	SCALE	NTS
RSS			05/23/95	2.1	

ABB DRAWING NO.	REV.	SHEET	CONTR.
CAB M94A-50002-01	0	2.1	of 43

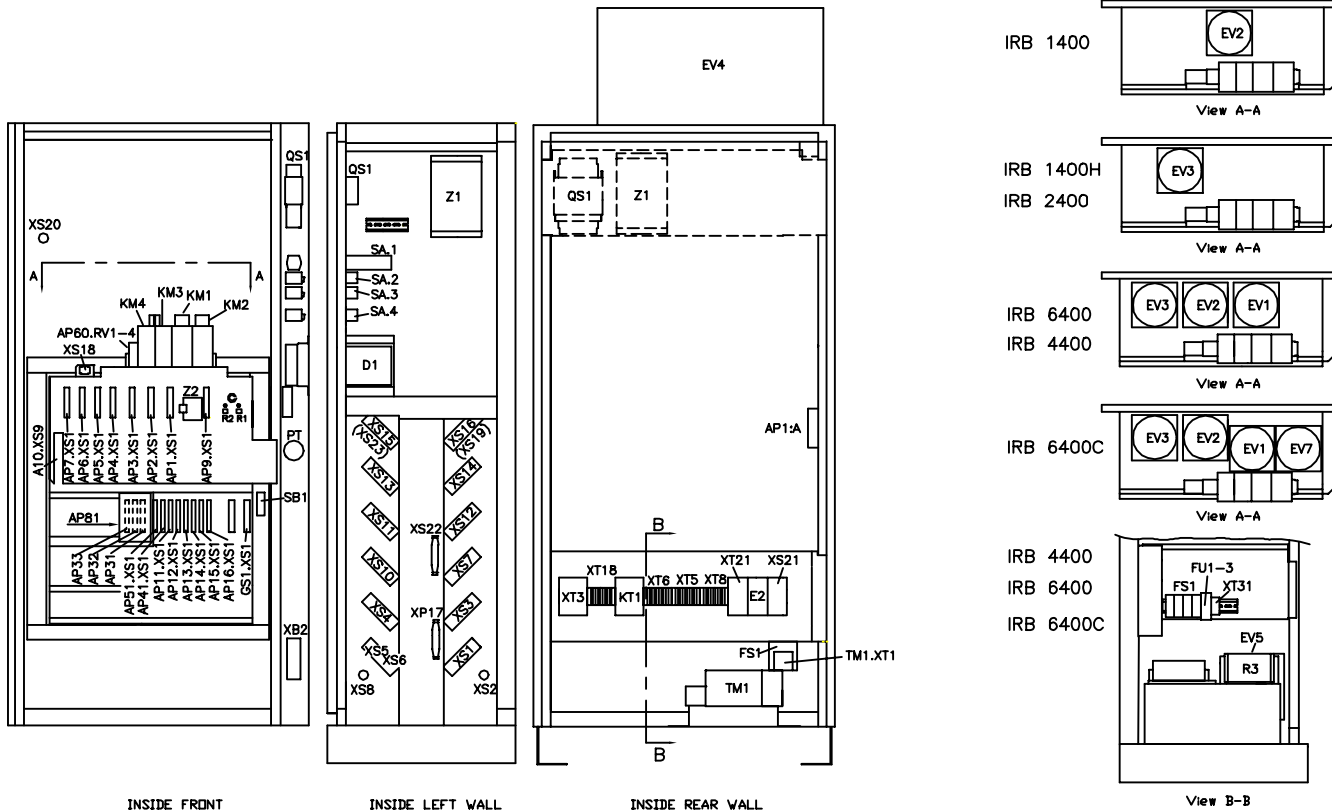

INSIDE FRONT

INSIDE LEFT WALL

INSIDE REAR WALL

View B-B

CABINET LAYOUT, LARGE SIZE (OPTION 112)

Preliminary Drawing

DATE: 05/23/95
ABB Flexible Automation

CONVERTED TO NORTH AMERICAN FORMAT
FROM EUROPEAN DOCUMENT No. 3HAB 2821-5

We reserve all rights in this document and in the information contained therein. Reproduction, use or disclosure to third parties without express authority is strictly forbidden.
ABB 19

3	RI 3645	1994 WK.05		
2	RI 3264	1994 WK.00		
1	RI 1296	1994 WK.35		
DET. NO.	REV. NO.	CHANGE	DATE	BY

ABB ABB Robot System Robotics Division		TITLE ELECTRICAL DIAGRAM CONTROL SYSTEM S4 M94A ABB PEDESTAL ROBOTS CAB. LAYOUT, LG. SIZE (OPT. 112)		
DESIGNED BY RSS	DRAWN BY RSS	CHECK BY RSS	DATE 05/23/95	SCALE 1:1
ABB DRAWING NO. CAB M94A-50002-02	REV. 3	SHEET 2.2	CONTR. NTS of 43 3	

A	Power unit	D1	Floppy disc unit	XP0	Mains Plug
A7A	ABB ESAB Connection	E2	Earth fault breaker	XP5	Customer signal connection
A7B	ABB ESAB Connection	EL	Illumination	XP6	Customer power connection
AP1A	ABB ESAB Connection	EV1	FAN, Drive system IRB 1400H/2400/3400/6400/6400C	XP17	Mode switch customer extension
AP1	Drive unit axis 1/1,3,5	EV2	FAN, Drive system IRB 1400/6400/6400C	XP18	PTC, Brake extension
AP2	Drive unit axis 2/2,4,6	EV3	FAN, Drive system IRB 1400-6400/6400C	XP19	External control panel connection
AP3	Drive unit axis 3	EV4	Cooling device	XP22	External axes, control signals extension
AP4	Drive unit axis 4/4-6	EV5	Main transformer fan, IRB 6400	XS1	Dirtlet control cable power
AP5	Drive unit axis 5	EV6	Back fan, Small cabinet size	XS2	Dirtlet control cable signal
AP6	Drive unit axis 6	EV7	FAN, Drive system IRB 6400C	XS3	Customer connection
AP7	Drive unit axis 7	FS1	Automatic Fuse, drive system	XS4	External axes signal connection, Axes board
AP9	DC-link Drive system	FS2	Automatic Fuse, Mains voltage	XS5	Customer signal connection
AP10	Drive unit back plane	FS3	Automatic Fuse, Service outlet	XS6	Customer power connection
AP11	Analogous I/O, Combi I/O, Dig I/O no 1	GB1	Battery	XS7	External axis power connection
AP12	Remote I/O, Digital I/O no 2	GB2	Battery	XS8	Position indicator
AP13	Remote I/O, Digital I/O no 3	GS1	Power supply	XS10	Analogous I/O, Combi I/O Analog part
AP14	Remote I/O, Digital I/O no 4	KM1	Motor on contactor 1	XS11	Digital I/O no 1
AP15	Remote I/O, Digital I/O no 5	KM2	Motor on contactor 2	XS12	Digital I/O no 2
AP16	Remote I/O, Digital I/O no 6	KM3	Supervision contactor	XS13	Digital I/O no 3
AP21	Relay output no 1	KM4	Brake contactor	XS14	Digital I/O no 4
AP22	Relay output no 2	KT1	Time delay, contactor	XS15	Digital I/O no 5
AP23	Relay output no 3	PT	Duty time counter	XS16	Digital I/O no 6
AP24	Relay output no 4	QS1	Mains switch	XS17	Mode switch customer extension
AP25	Relay output no 5	R1, R2	Resistors, DC-link	XS18	PTC, Brake extension
AP26	Relay output no 6	R3	Brake resistor IRB 6400	XS19	External control panel connection
		RV1	Varistor, Motor on contactor 1	XS20	Programming unit outlet
AP31	Robot computer	RV2	Varistor, Motor on contactor 2	XS21	Service 230V outlet
AP32	Main computer	RV4	Varistor, Brake contactor	XS22	External axes, control signal extension
AP33	Memory board	SA	Control panel	XS23	External axes signal connection, SMB
AP41	System board	SA1	Mode switch	XT3	Customer connection
AP51	External axes board	SA2	Motor on, PB	XT5	Customer signal connection
AP60	Varistor and diode unit	SA3	Motor off PB	XT6	Customer power connection
AP61	Serial measurement board	SA4	Emergency stop PB	XT8	Position indicator
AP61GB	SMB battery	SB1	Door switch drive system fan	XT10	Analogous I/O, Combi I/O analog part
AP80	Interface back plane	SB2	Door switch, Heat exchanger, Air conditioning	XT11	Digital I/O no 1
AP80.F1-4	PTC Resistor Fuse	SB3	Door switch illumination	XT12	Digital I/O no 2
AP80.X2	Floppy disc signal	TM1	Transformer, Mains	XT13	Digital I/O no 3
AP80.X22	Floppy disc power	TMLFU1-3	Fuse	XT14	Digital I/O no 4
AP80.X5	Data ports, SID 1-4	TMLST	Temperature sensor, transformer	XT15	Digital I/O no 5
AP80.X31	Measurement system	TM2	Transformer, Service outlet	XT16	Digital I/O no 6
AP80.X32	Programming unit	V1	Diode duty time counter	XT17	Remote I/O board
AP80.X34	Control panel	V3	Diode supervision contactor	XT18	I/O supply
AP80.X35	System board, customer	XB1	Computer link	XT21	Service outlet connection
AP81	Computer board back plane	XB2	Print out	XT26	Direct supply connection
				Z1	Mains Filter
				Z2	Filter Lin. Switch robot

Preliminary Drawing

NOT CHECKED!

DATE: 05/23/95

ABB Flexible Automation

CONVERTED TO NORTH AMERICAN FORMAT
FROM EUROPEAN DOCUMENT No. 3HAB 2821-5

We reserve all rights in this document and in the information contained therein. Reproduction, use or disclosure to third parties without express authority is strictly forbidden.

ABB 19

2	RI 1364			1994 WK.00
1	RI 1396			1994 WK.35
DET. NO.	REV. NO.	CHANGE	DATE	BY
ABB ABB Flexible Automation Robotics Division		WIRE ELECTRICAL DIAGRAM CONTROL SYSTEM S4 M94A ABB PEDESTAL ROBOTS DESIGNATION		
DESIGNED BY	DRAWN BY	CHECK BY	DATE	SCALE
			05/23/95	NTS
ABB DRAWING NO.	REV.	SHEET	CONT'D	
CAB M94A-50003-00	2	3		of 43 4

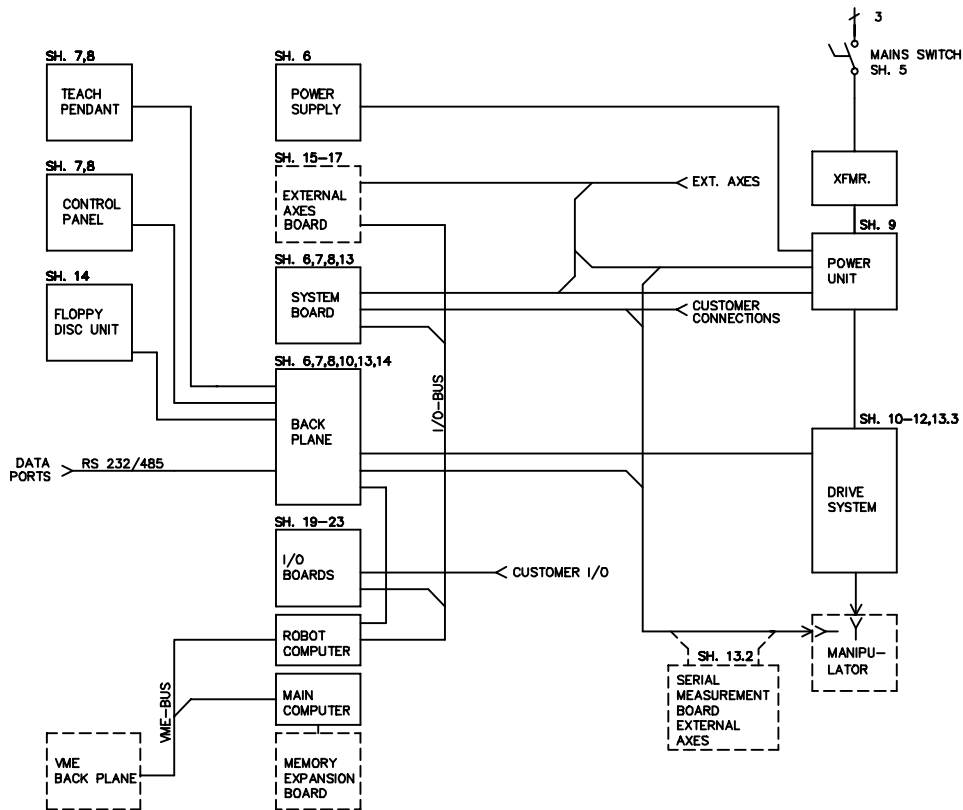

Preliminary Drawing
 DATE: 05/23/95
 ABB Flexible Automation

CONVERTED TO NORTH AMERICAN FORMAT
 FROM EUROPEAN DOCUMENT No. 3HAB 2821-5

DET. NO.	REV. NO.	CHANGE	DATE	BY
ABB <small>ABB BROSSE ROBOTICS</small> <small>Robotics Division</small>				
TITLE ELECTRICAL DIAGRAM CONTROL SYSTEM S4 M94A ABB PEDESTAL ROBOTS BLOCK DIAGRAM				
DESIGNED BY	DRAWN BY	CHECK BY	DATE	SCALE
	RSS		05/23/95	N/A
ABB DRAWING NO.	REV.	SHEET	CONT'D.	
CAB M94A-50004-00	0	4		of 435

- 05 00
- 05 01
- 05 02
- 05 03
- 05 04
- 05 05
- 05 06
- 05 07
- 05 08
- 05 09
- 05 10
- 05 11
- 05 12
- 05 13
- 05 14
- 05 15
- 05 16
- 05 17
- 05 18
- 05 19
- 05 20

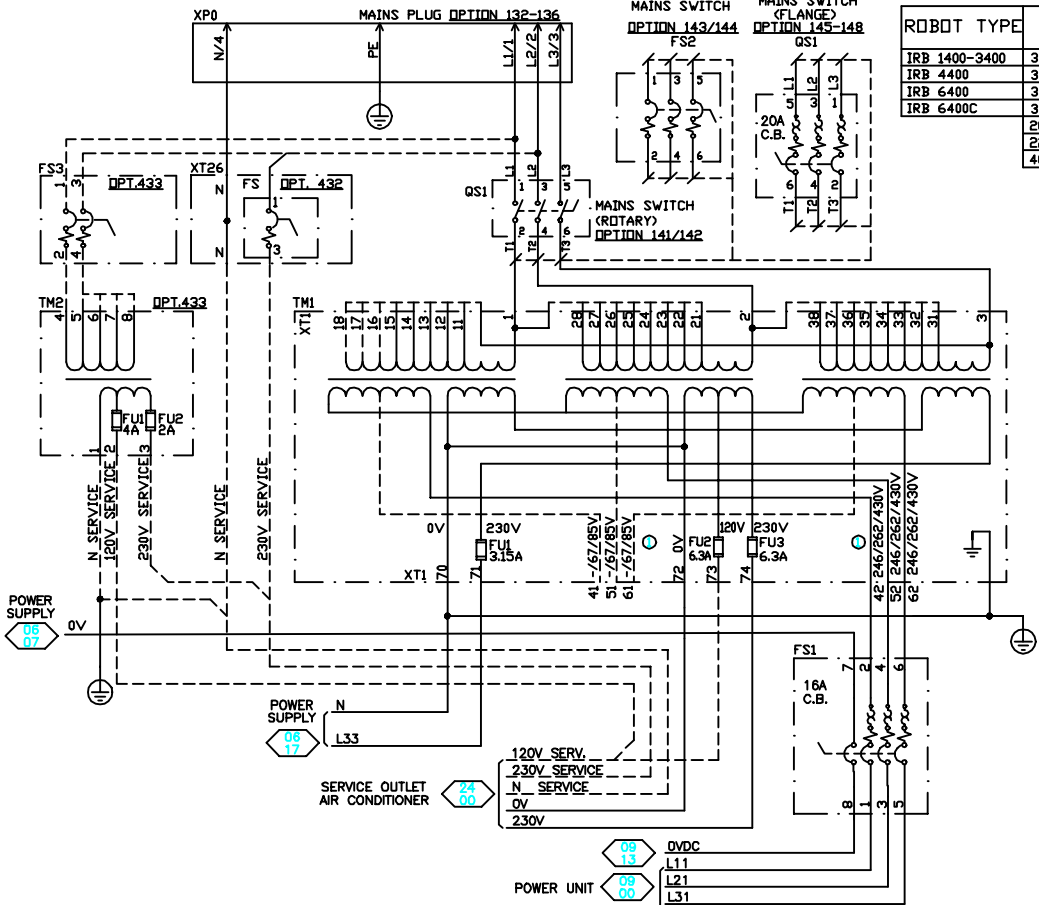

ROBOT TYPE	TM1 MAINS VOLTAGE			JUMPERS
IRB 1400-3400	3HAB2952-1	3HAB2950-1	3HAB2951-1	(PRI, DELTA SIDE)
IRB 4400	3HAB2947-1	3HAB2945-1	3HAB2946-1	
IRB 6400	3HAB2947-1	3HAB2945-1	3HAB2946-1	
IRB 6400C	3HAB5101-1	3HAB2998-1	3HAB2999-1	
200V				1-21, 2-31, 3-11
220V				1-22, 2-32, 3-12
400V	400V			1-23, 2-33, 3-13
	440V			1-24, 2-34, 3-14
	475V	475V		1-25, 2-35, 3-15
	500V	500V		1-26, 2-36, 3-16
	525V			1-27, 2-37, 3-17
	600V			1-28, 2-38, 3-18

TM2 SERVICE OUTLET TRANSFORMER (DPT.433)	
TRANS-FORMER	PRIMARY CONNECTION
3HAB 5316-1	400V 440V 475V 500V
	5 6 7 8

Preliminary Drawing
 NOT CHECKED!
 DATE: 05/23/95
 ABB Flexible Automation

CONVERTED TO NORTH AMERICAN FORMAT FROM EUROPEAN DOCUMENT No. 3HAB 2821-5

○ IRB OTHERS/IRB 4400,6400/C.

We reserve all rights in this document and in the information contained therein. Reproduction, use or disclosure to third parties without express authority is strictly forbidden. ABB 19

3	RI 1645	3995 WK.05
2	RI 1364	3994 WK.00
DET. NO.	CHANGE	DATE BY
ABB FLEXIBLE AUTOMATION ABB ELECTRIC SCANDINAVIA Robotics Division		
DESIGNED BY	DRAWN BY	CHECK BY
DATE: 05/23/95	SCALE	N/A
ABB DRAWING NO.	REV.	SHEET
CAB M94A-50005-00	3 5	of 436

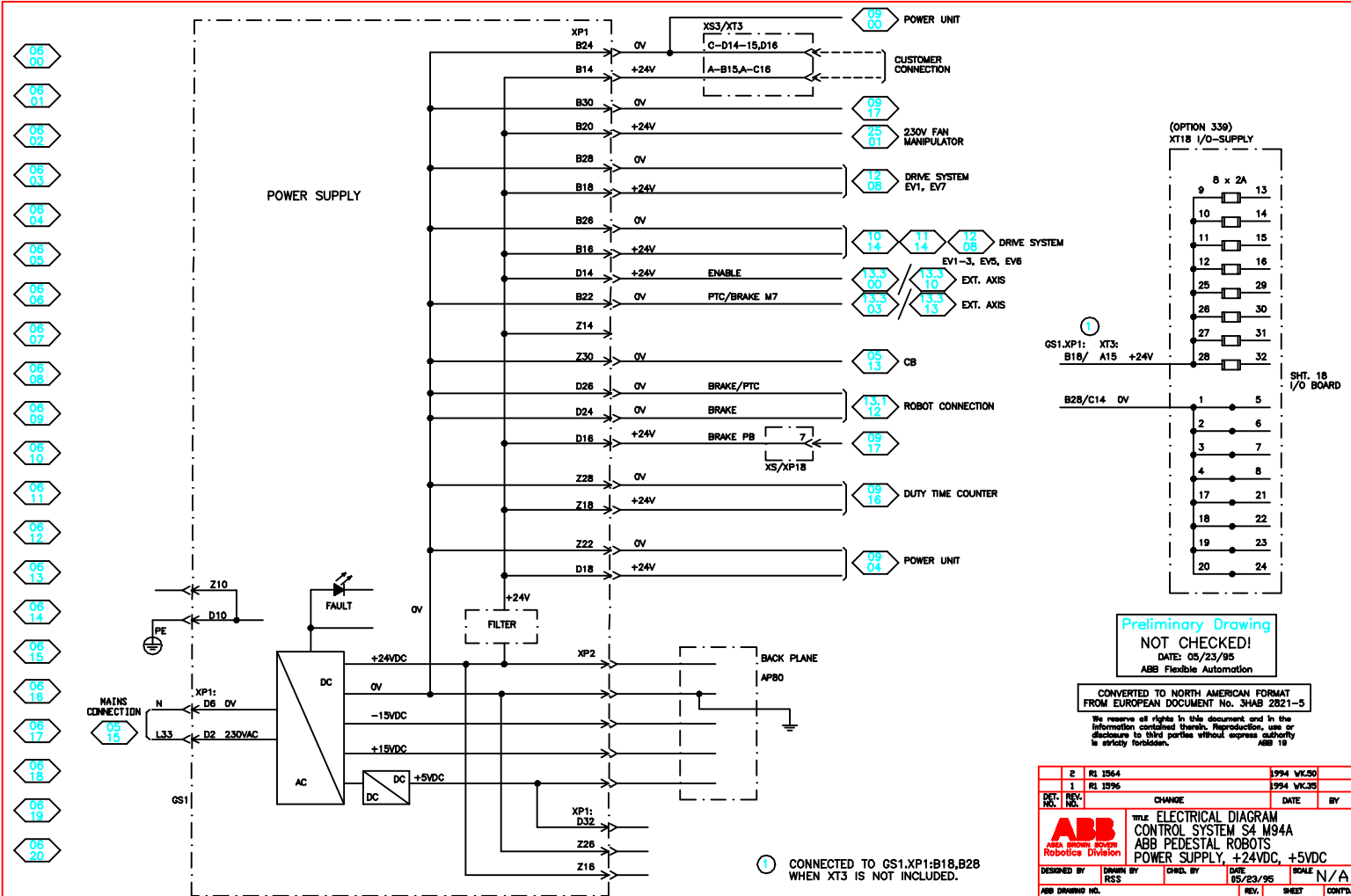

POWER SUPPLY

POWER UNIT

CUSTOMER CONNECTION

230V FAN MANIPULATOR

DRIVE SYSTEM EV1, EV7

DRIVE SYSTEM EV1-3, EV5, EV6

EXT. AXIS

EXT. AXIS

CB

ROBOT CONNECTION

BRAKE PB

DUTY TIME COUNTER

POWER UNIT

(OPTION 339)
XT18 I/O-SUPPLY

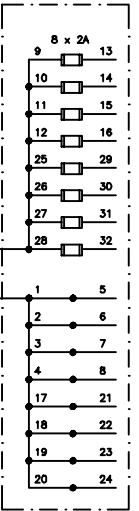

SHT. 16
I/O BOARD

Preliminary Drawing
NOT CHECKED!
DATE: 05/23/95
ABB Flexible Automation

CONVERTED TO NORTH AMERICAN FORMAT
FROM EUROPEAN DOCUMENT No. 3HAB 2821-5

We reserve all rights in this document and in the information contained therein. Reproduction, use or disclosure to third parties without express authority is strictly forbidden.
ABB 19

2	RI 1264	3994 WK.00
1	RI 1296	3994 WK.25
DET. NO.	CHANGE	DATE BY

ABB **ABB** **ABB**
 ABB BROWN BOYCE Robotics Division
 TITLE ELECTRICAL DIAGRAM
 CONTROL SYSTEM S4 M94A
 ABB PEDESTAL ROBOTS
 POWER SUPPLY, +24VDC, +5VDC

DESIGNED BY	DRAWN BY	CHECK BY	DATE	SCALE	N/A
ABB DRAWING NO.	REV.	SHEET	CONTR.		
CAB M94A-50006-00	2	6	of 43		

1 CONNECTED TO GS1.XP1:B18, B28 WHEN XT3 IS NOT INCLUDED.

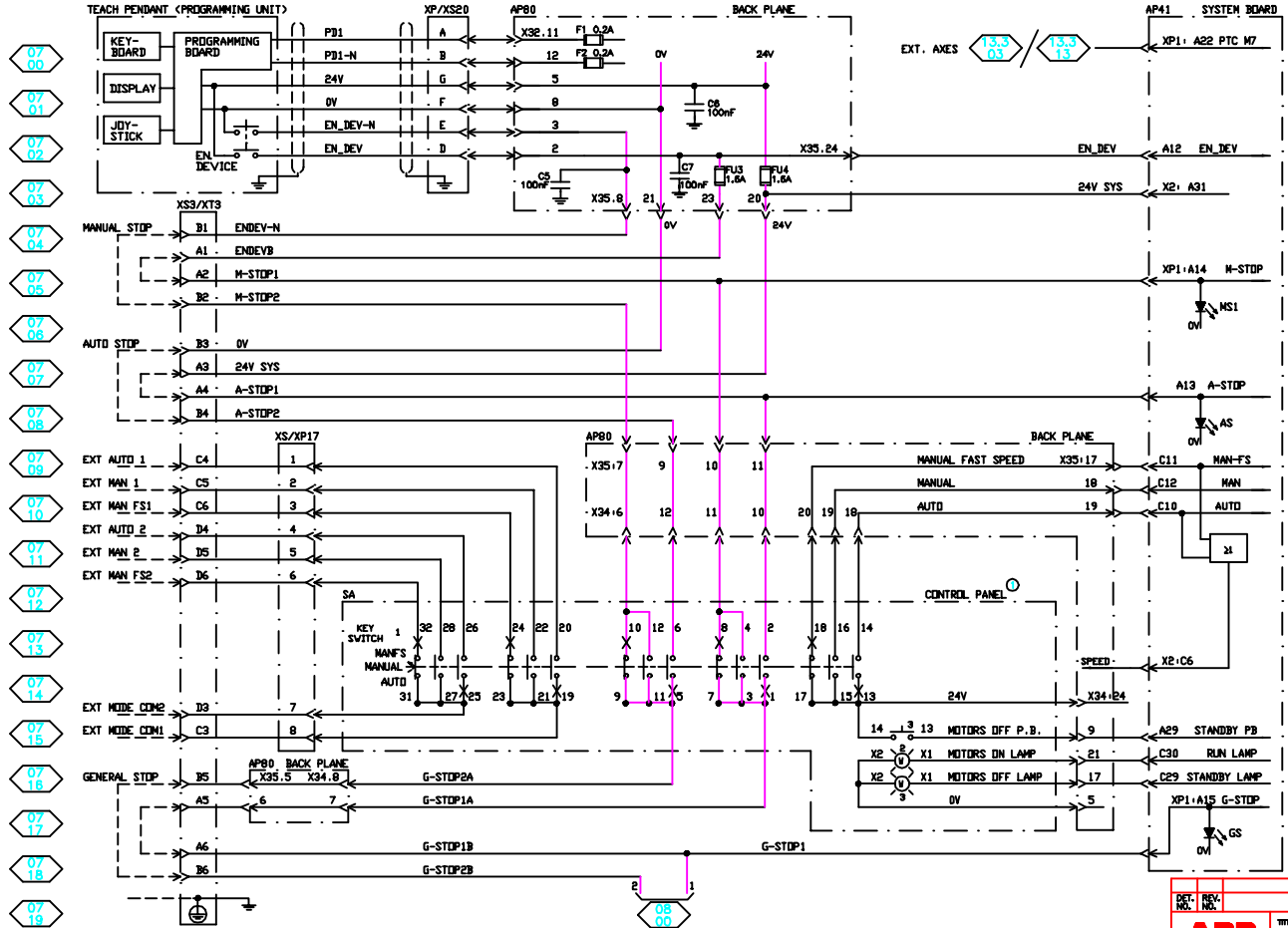

- 07 00
- 07 01
- 07 02
- 07 03
- 07 04
- 07 05
- 07 06
- 07 07
- 07 08
- 07 09
- 07 10
- 07 11
- 07 12
- 07 13
- 07 14
- 07 15
- 07 16
- 07 17
- 07 18
- 07 19
- 07 20

External Control Panel connections on sht. 27.

Preliminary Drawing
NOT CHECKED!
DATE: 05/23/95
ABB Flexible Automation

CONVERTED TO NORTH AMERICAN FORMAT FROM EUROPEAN DOCUMENT No. 3HAB 2821-5

We reserve all rights in this document and in the information contained therein. Reproduction, use or disclosure to third parties without express authority is strictly forbidden.

DET. REV. NO.	CHANGE	DATE	BY
05		05/23/95	RSS

ABB ABB Robot System Robotics Division

TITLE: ELECTRICAL DIAGRAM
 CONTROL SYSTEM S4 M94A
 ABB PEDESTAL ROBOTS
 MOTOR ON CHAIN PART 1

DESIGNED BY	DRAWN BY	CHECK BY	DATE	SCALE
RSS			05/23/95	N/A

ABB DRAWING NO. CAB M94A-50007-00
 REV. 0
 SHEET 18
 OF 43

- 08 00
- 08 01
- 08 02
- 08 03
- 08 04
- 08 05
- 08 06
- 08 07
- 08 08
- 08 09
- 08 10
- 08 11
- 08 12
- 08 13
- 08 14
- 08 15
- 08 16
- 08 17
- 08 18
- 08 19
- 08 20

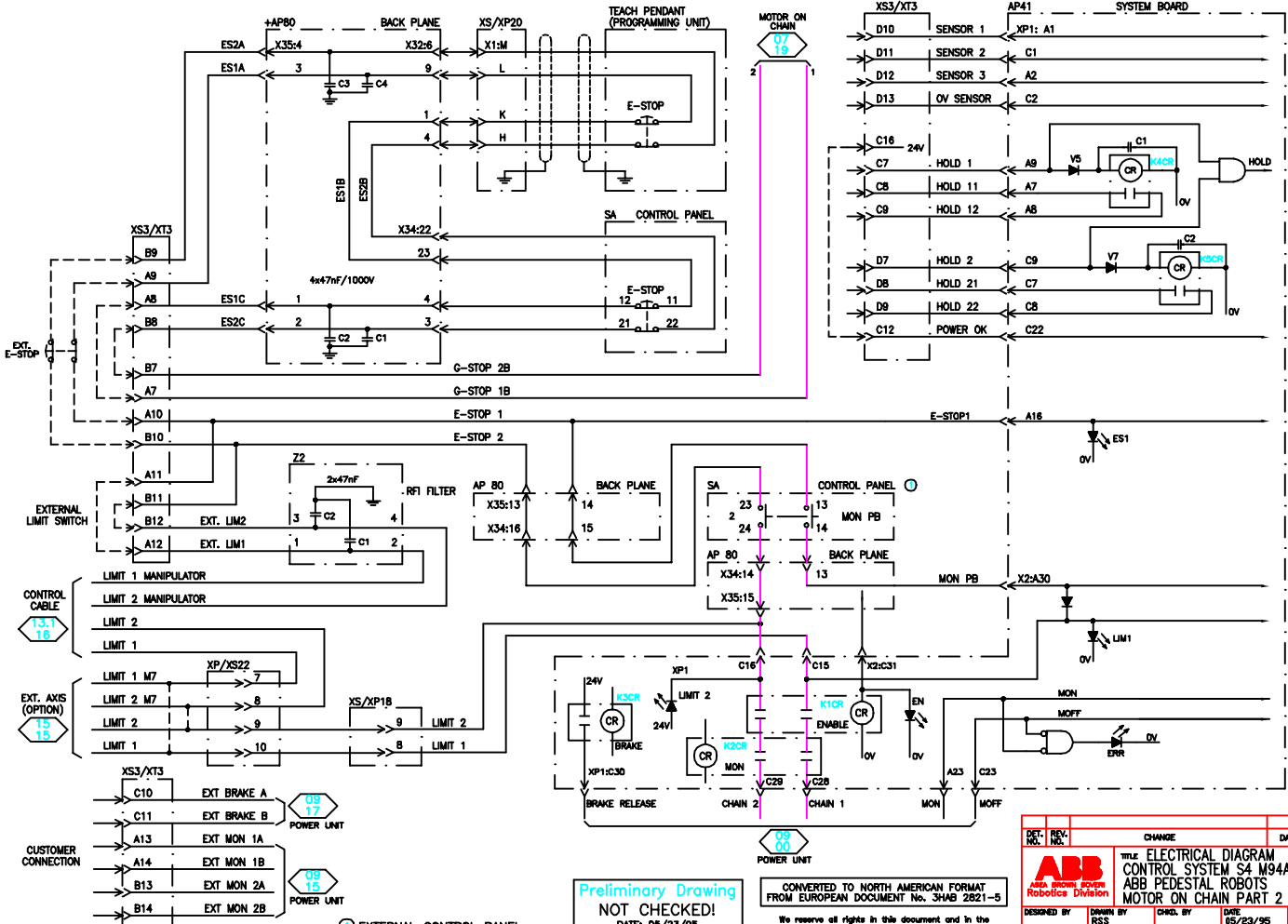

EXTERNAL CONTROL PANEL CONNECTIONS ON SHT. 26

Preliminary Drawing
NOT CHECKED!
DATE: 05/23/95
ABB Flexible Automation

CONVERTED TO NORTH AMERICAN FORMAT FROM EUROPEAN DOCUMENT No. 3HAB 2821-5
We reserve all rights in this document and in the information contained therein. Reproduction, use or disclosure to third parties without express authority is strictly forbidden.
ABB 10

DET. REV. NO.	CHANGE	DATE	BY
ABB <small>ABB Robot System Division</small>			
WIRE ELECTRICAL DIAGRAM CONTROL SYSTEM S4 M94A ABB PEDESTAL ROBOTS MOTOR ON CHAIN PART 2			
DESIGNED BY	DRAWN BY	CHECK BY	DATE
			05/23/95
ABB DRAWING NO.	REV.	SHEET	SCALE
CAB M94A-50008-00	0	8	N/A
			DATE
			05/23/95
			08
			of 43

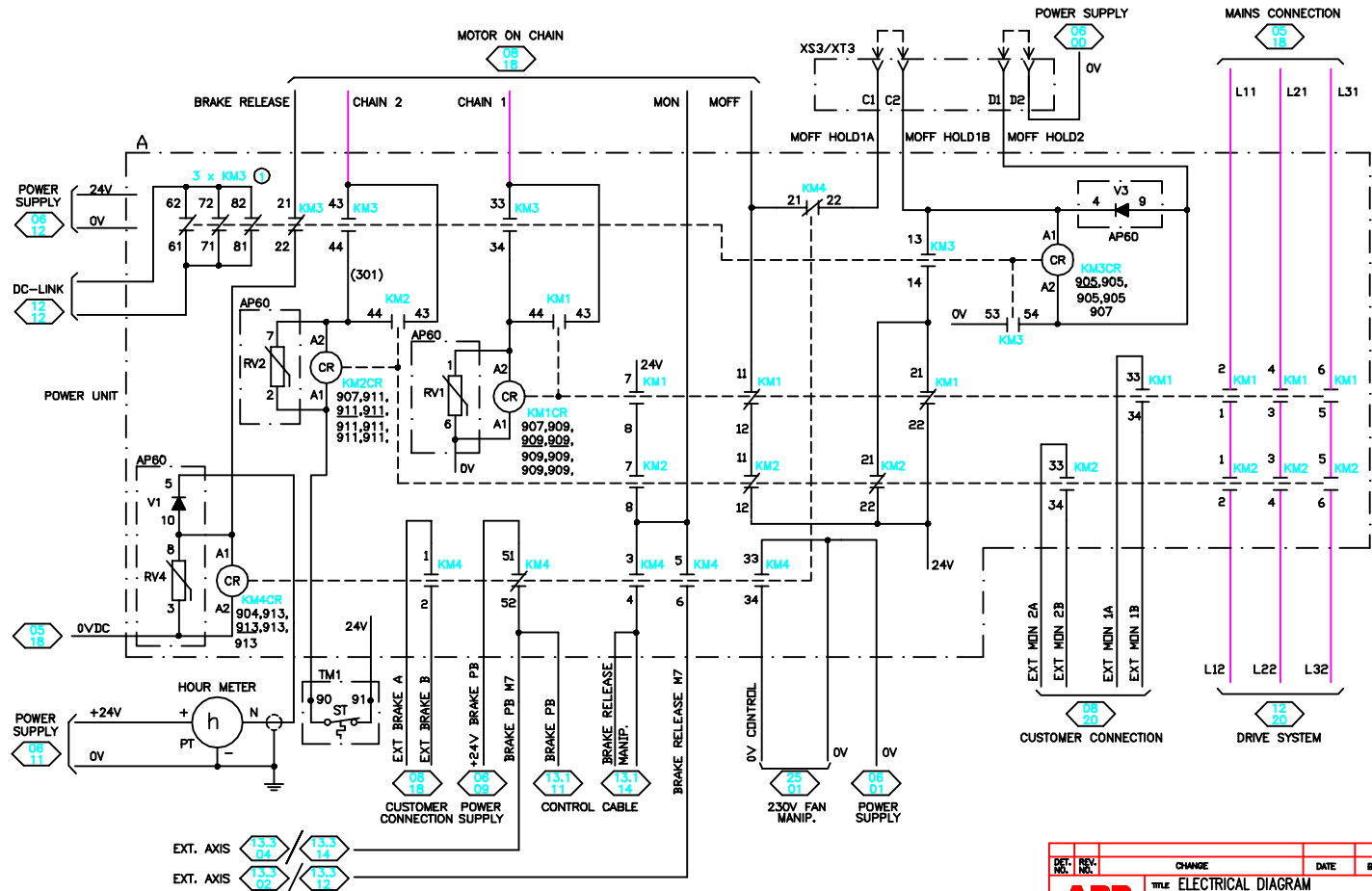

○ ONLY IRB 6400.

Preliminary Drawing
 NOT CHECKED!
 DATE: 05/23/95
 ABB Flexible Automation

CONVERTED TO NORTH AMERICAN FORMAT
 FROM EUROPEAN DOCUMENT No. 3HAB 2821-5

We reserve all rights in this document and in the information contained therein. Reproduction, use or disclosure to third parties without express authority is strictly forbidden.
 ABB 19

DET. REV. NO.	CHANGE	DATE	BY

ABB ABB Inverter Supply Robotics Division **WILE ELECTRICAL DIAGRAM**
CONTROL SYSTEM S4 M94A
ABB PEDESTAL ROBOTS
POWER UNIT

DESIGNED BY	DRAWN BY	CHECK BY	DATE	SCALE	N/A
			05/23/95		

ABB DRAWING NO. CAB M94A-50009-00
 REV. 01
 SHEET 9
 OF 43

10 00
10 01
10 02
10 03
10 04
10 05
10 06
10 07
10 08
10 09
10 10
10 11
10 12
10 13
10 14
10 15
10 16
10 17
10 18
10 19
10 20

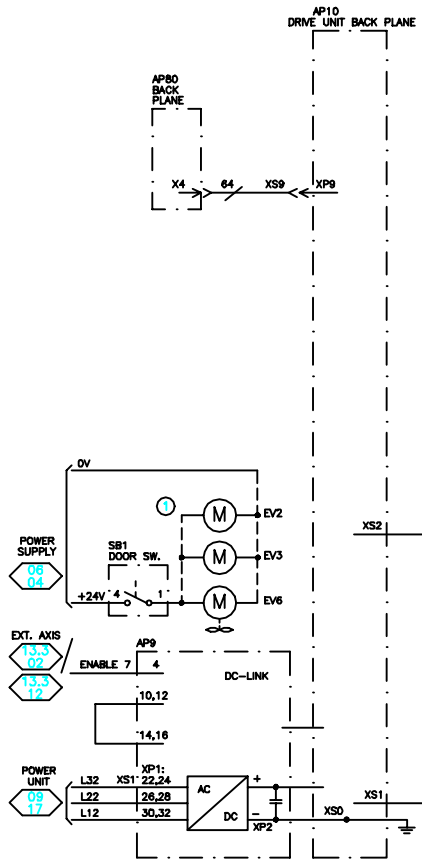

AP10
DRIVE UNIT BACK PLANE

AP80
BACK PLANE

X4 64 XS9 XP9

POSITIONS OF DRIVE UNITS

ROBOT TYPE	AXIS		DC-LINK
	1,2,3	2,4,6	
IRB 1400	D	D	A

D=3HAB 2207-1
DC-LINK A=3HAB 2215-1

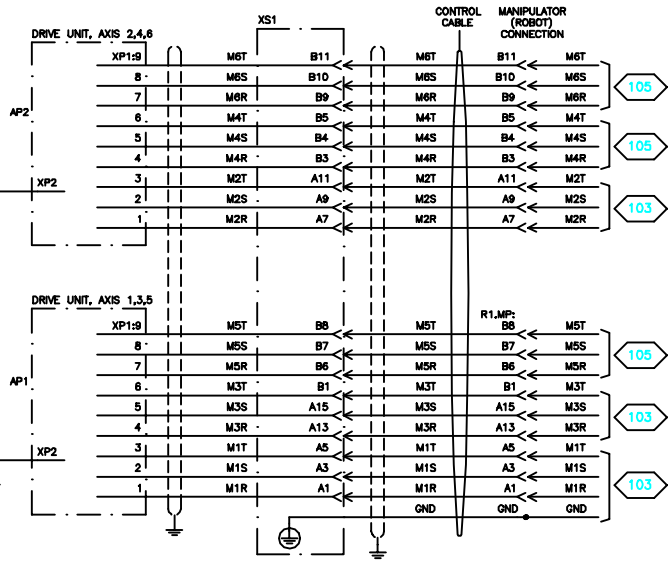

① DRIVE UNIT FAN EV2, EV3 & BACK FAN EV6 WHEN SMALL CABINET SIZE, WHEN LARGE EV2.

Preliminary Drawing
NOT CHECKED!
DATE: 05/23/95
ABB Flexible Automation

CONVERTED TO NORTH AMERICAN FORMAT FROM EUROPEAN DOCUMENT No. 3HAB 2821-5

We reserve all rights in this document and in the information contained therein. Reproduction, use or disclosure to third parties without express authority is strictly forbidden. ABB 19

DEF. NO.	REV. NO.	CHANGE	DATE	BY

ABB **ABB** **ABB**
 ALBA BROSSE ROYER Robotics Division
 WUX ELECTRICAL DIAGRAM
 CONTROL SYSTEM S4 M94A
 ABB PEDESTAL ROBOTS
 DRIVE SYSTEM IRB 1400

DESIGNED BY	DRAWN BY	CHECK BY	DATE	SCALE
			05/23/95	N/A

ABB DRAWING NO.	REV.	SHEET	CONTR.
CAB M94A-50010-00	0	10	of 43 11

11 00
11 01
11 02
11 03
11 04
11 05
11 06
11 07
11 08
11 09
11 10
11 11
11 12
11 13
11 14
11 15
11 16
11 17
11 18
11 19
11 20

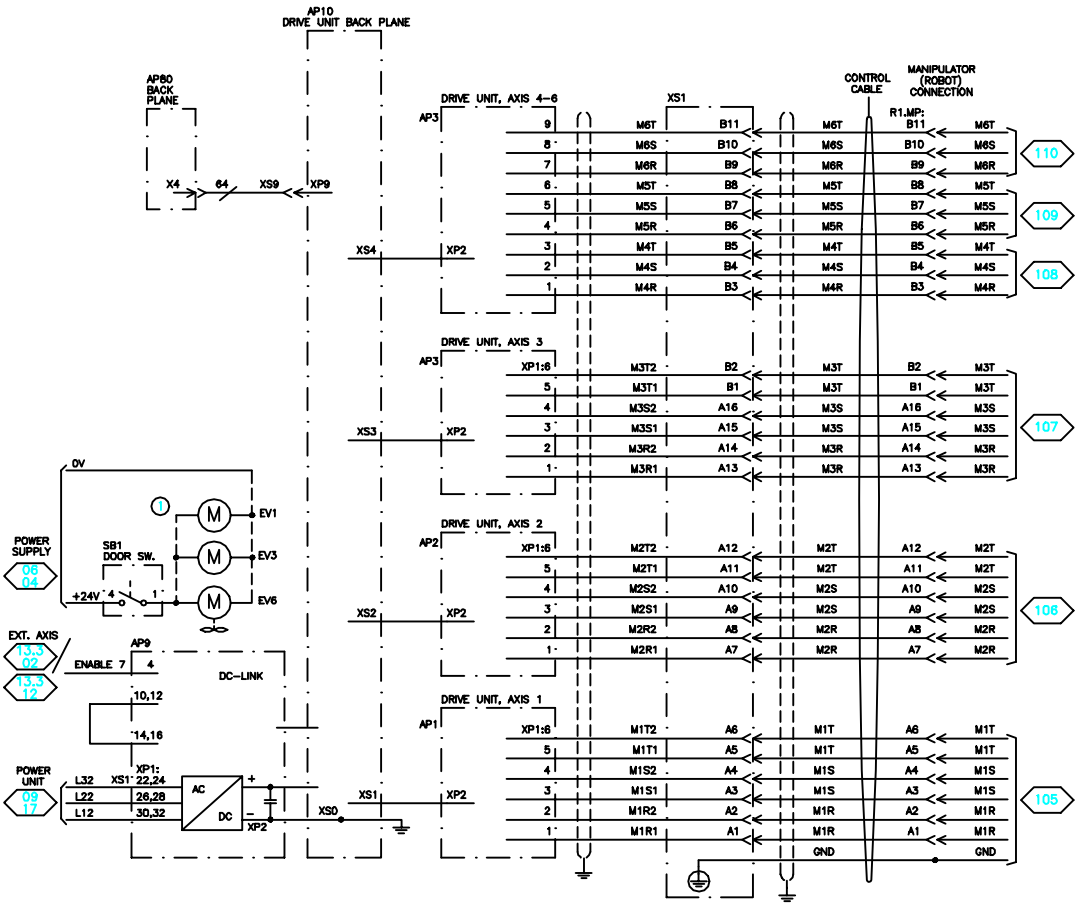

POSITIONS OF DRIVE UNITS

ROBOT TYPE	AXIS				DC-LINK
	1	2	3	4-6	
IRB 1400H	A	B	A	D	A
IRB 2400	B	C	B	D	A

A= YB 560 103-CA
B= YB 560 103-CB
C= YB 560 103-CC
D=3HAB 2207-1
DC-LINK A=3HAB 2215-1

① DRIVE UNIT FAN EV1, EV3 & BACK FAN EV6 WHEN SMALL CABINET SIZE, WHEN LARGE EV3.

Preliminary Drawing
NOT CHECKED!
DATE: 05/23/95
ABB Flexible Automation

CONVERTED TO NORTH AMERICAN FORMAT FROM EUROPEAN DOCUMENT No. 3HAB 2821-5

We reserve all rights in this document and in the information contained therein. Reproduction, use or disclosure to third parties without express authority is strictly forbidden. ABB 18

DET. NO.	REV. NO.	CHANGE	DATE	BY
ABB				
<p>W/E ELECTRICAL DIAGRAM CONTROL SYSTEM S4 M94A ABB PEDESTAL ROBOTS DRIVE SYSTEM IRB 1400/H & 2400</p>				
DESIGNED BY	DRWN BY	CHKD BY	DATE	SCALE
RSS			05/23/95	N/A
ABB DRAWING NO.	REV.	DATE	CONTR.	
CAB M94A-50011-00	0	11	of 43 12	

POSITIONS OF DRIVE UNITS

ROBOT TYPE	AXIS					DC-LINK
	1	2	3	4	5	6
IRB 3400 B2-01	C	C	C	B	A	A
IRB 3400 LFC-00	C	C	C	B	A	A
IRB 6400 B2FC-75	U	T	T	U	U	U
IRB 4400 DTW02	T	T	T	U	U	U
IRB 6400C	T	T	T	U	U	C
IRB 4400 T	T	T	H	H	H	B

A= YB 560 103-CA
 B= YB 560 103-CB
 C= YB 560 103-CC
 G= YB 560 103-CD
 H= 3HA3 B245-1
 T= YB 560 103-CE
 U= 3HAM 3563-ANA
 DC-LINK A= 3HAB 2215-1
 DC-LINK B= 3HAB 2216-1
 DC-LINK C= 3HAB 2231-1

- ① ONLY IRB 440, 6400.
- ② JUMPER WHEN NOT IRB 4400, 6400.
- ③ IRB 3400: DRIVE UNIT FAN EV1, EV3 & BACK FAN EVS WHEN SMALL CABINET SIZE.
IRB 4400, 6400: DRIVE UNIT FAN EV1-EV3 & TRANSFORMER FAN EV5.
- ④ ONLY IRB 6400C.

Preliminary Drawing
 NOT CHECKED!
 DATE: 05/23/95
 ABB Flexible Automation

CONVERTED TO NORTH AMERICAN FORMAT
 FROM EUROPEAN DOCUMENT No. 3HAB 2821-5

We reserve all rights in this document and in the information contained therein. Reproduction, use or disclosure to third parties without express authority is strictly forbidden. ABB 19

3	RI 1645	3995	WIK/OS
2	RI 1364	3994	WIK/OS
DET. NO.	CHANGE	DATE	BY
ABB WILE ELECTRICAL DIAGRAM CONTROL SYSTEM S4 M94A ABB PEDestal ROBOTs -IRB 3400/ 4400/6400/6400C DRIVE SYSTEM ABB InnoVate Systems Robotics Division			
DESIGNED BY	DRAWN BY	CHECK BY	DATE
			05/23/95
ABB DRAWING NO.	REV.	SHEET	CONTR.
CAB M94A-50012-00	3	12	of 43 13.1

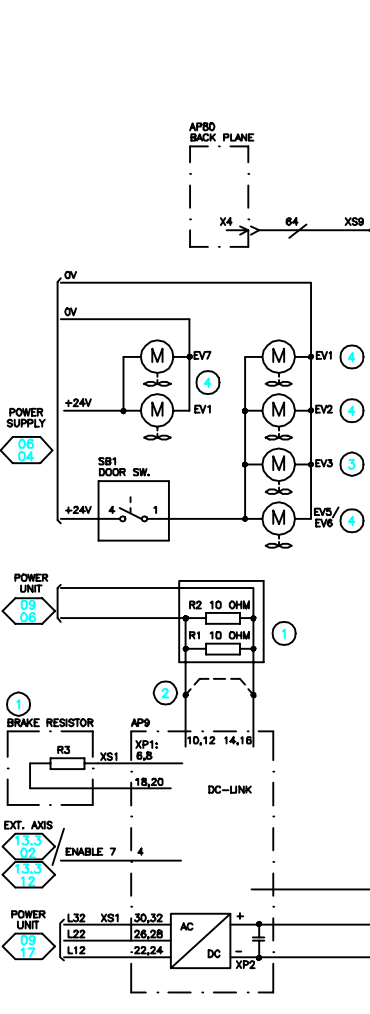
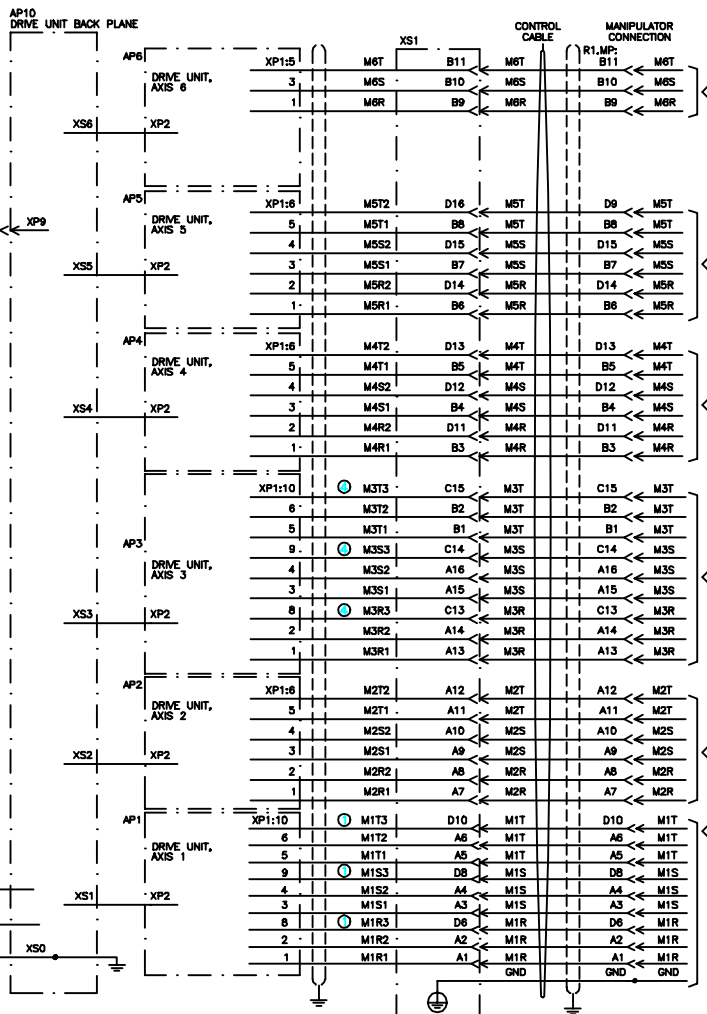

- 12 00
- 12 01
- 12 02
- 12 03
- 12 04
- 12 05
- 12 06
- 12 06
- 12 07
- 12 08
- 12 09
- 12 10
- 12 11
- 12 12
- 12 13
- 12 14
- 12 15
- 12 16
- 12 16
- 12 17
- 12 18
- 12 19
- 12 20

13.1 00
13.1 01
13.1 02
13.1 03
13.1 04
13.1 05
13.1 06
13.1 07
13.1 08
13.1 09
13.1 10
13.1 11
13.1 12
13.1 13
13.1 14
13.1 15
13.1 16
13.1 17
13.1 18
13.1 19
13.1 20

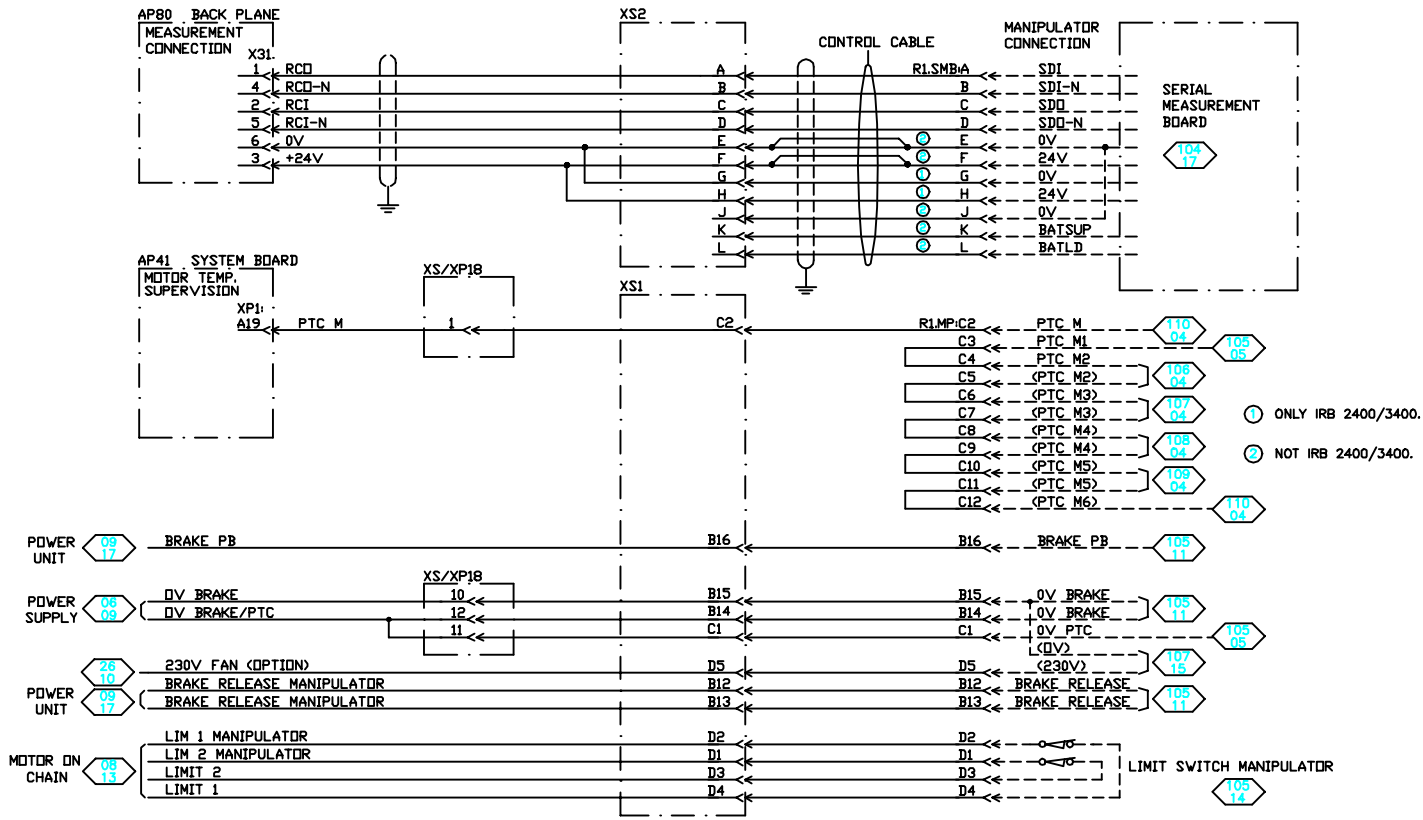

Preliminary Drawing
NOT CHECKED!
DATE: 05/23/95
ABB Flexible Automation

CONVERTED TO NORTH AMERICAN FORMAT
FROM EUROPEAN DOCUMENT No. 3HAB 2821-5

We reserve all rights in this document and in the information contained therein. Reproduction, use or disclosure to third parties without express authority is strictly forbidden. ABB 19

DET. NO.	REV. NO.	CHANGE	DATE	BY
ABB ABB Flexible Automation Division				
TITLE: ELECTRICAL DIAGRAM CONTROL SYSTEM S4 M94A ABB PEDESTAL ROBOTS CONTROL CABLE				
DESIGNED BY	DRWN BY	CHKD. BY	DATE	SCALE
	RSS		05/23/95	N/A
ABB DRAWING NO.	REV.	SHEET	CONT.	
CAB M94A-50013-01	0	13.1	of 4313.2	

- 13.2 00
- 13.2 01
- 13.2 02
- 13.2 03
- 13.2 04
- 13.2 05
- 13.2 06
- 13.2 07
- 13.2 08
- 13.2 09
- 13.2 10
- 13.2 11
- 13.2 12
- 13.2 13
- 13.2 14
- 13.2 15
- 13.2 16
- 13.2 17
- 13.2 18
- 13.2 19
- 13.2 20

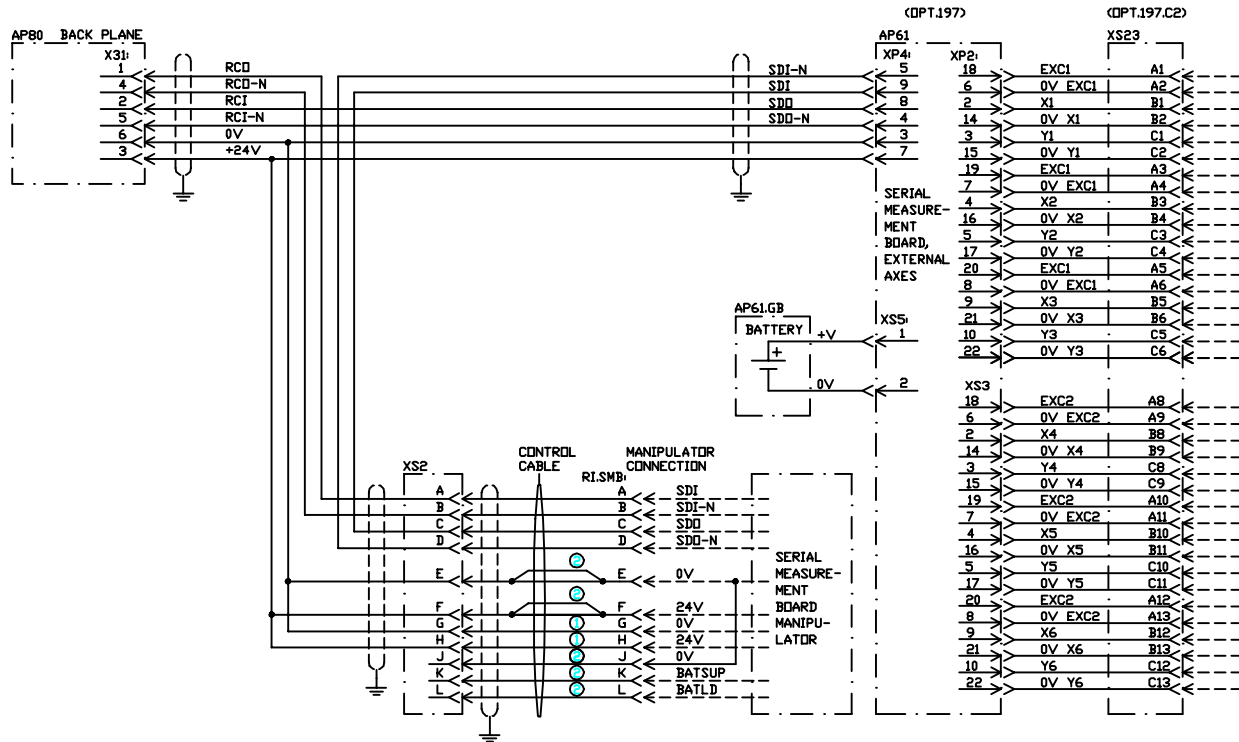

- ONLY IRB 2400/3400.
- NOT IRB 2400/3400.

Preliminary Drawing

DATE: 05/23/95

ABB Flexible Automation

CONVERTED TO NORTH AMERICAN FORMAT FROM EUROPEAN DOCUMENT No. 3HAB 2821-5

We reserve all rights in this document and in the information contained therein. Reproduction, use or disclosure to third parties without express authority is strictly forbidden.

1	RE 1396	1994 WK35
DET. NO.	REV. NO.	CHANGE DATE BY
TITLE: ELECTRICAL DIAGRAM CONTROL SYSTEM S4 M94A ABB PEDESTAL ROBOTS SER. MEASUREMENT BD., EXT. AXIS		
DESIGNED BY	DRAWN BY	CHKD. BY
DATE	DATE	SCALE
05/23/95		N/A
ABB DRAWING NO.	REV.	SHEET
CAB M94A-50013-02	1	13.2 of 43
CONF.	CONF.	CONF.

13.3 00
13.3 01
13.3 02
13.3 03
13.3 04
13.3 05
13.3 06
13.3 07
13.3 08
13.3 09
13.3 10
13.3 11
13.3 12
13.3 13
13.3 14
13.3 15
13.3 16
13.3 17
13.3 18
13.3 19
13.3 20

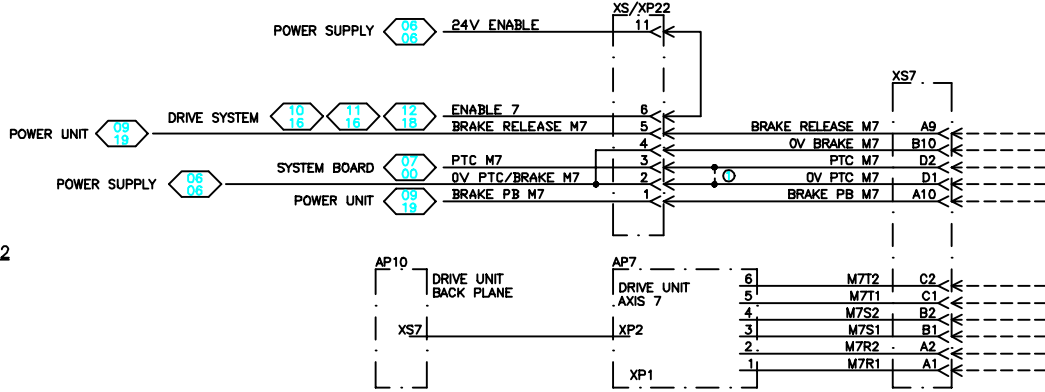
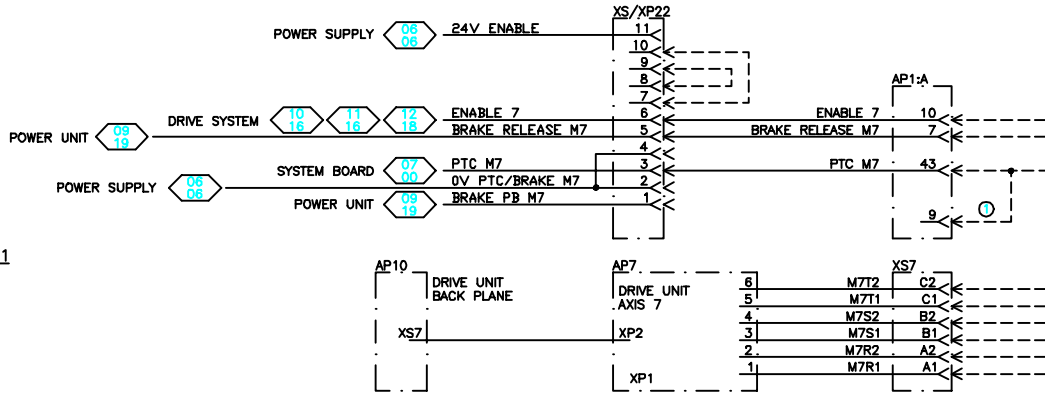

NOTE: TYPE OF INTEGRATED DRIVE UNIT
 C=YB 560 103-CC
 T=YB 560 103-CE

○ LINK WHEN NOT AXIS 7.

Preliminary Drawing
 NOT CHECKED!
 DATE: 05/23/95
 ABB Flexible Automation

CONVERTED TO NORTH AMERICAN FORMAT
 FROM EUROPEAN DOCUMENT No. 3HAB 2821-5

We reserve all rights in this document and in the information contained therein. Reproduction, use or disclosure to third parties without express authority is strictly forbidden.
 ABB 19

3	RL 1659	1995 WK.05
DET. NO.	REV. NO.	CHANGE
DATE		BY
ABB <small>ABB Inverter Systems Robotics Division</small>		
TITLE: ELECTRICAL DIAGRAM CONTROL SYSTEM S4 M94A ABB PEDESTAL ROBOTS INTEGRATED DRIVE UNIT, EXT. AXIS		
DESIGNED BY	DRAWN BY	CHKD. BY
RSS		
DATE	SCALE	N/A
05/23/95		
ABB DRAWING NO.	REV.	SHEET
CAB M94A-50013-03	3	13.3 of 43
CONT.		

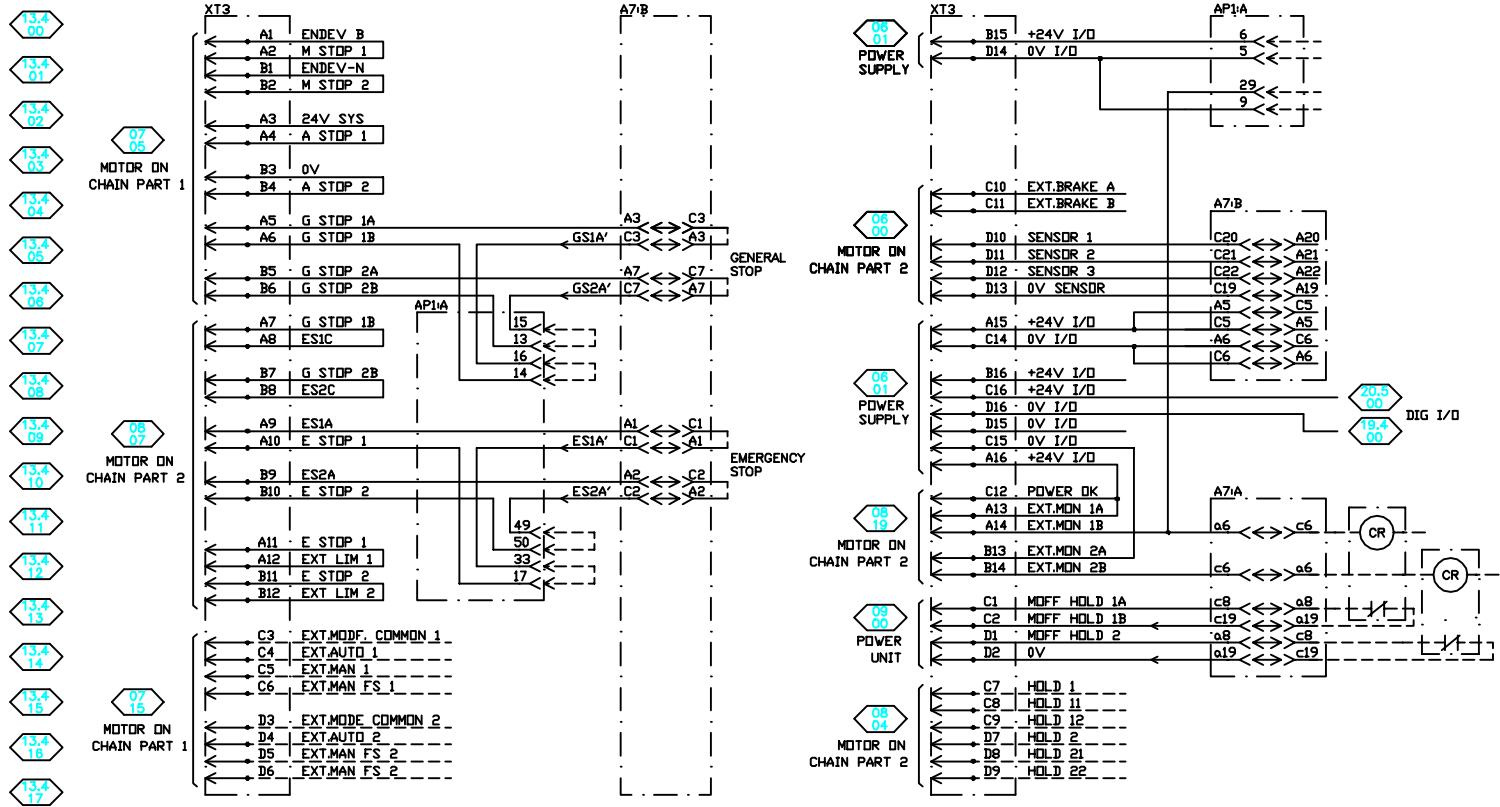

OPTION 32X

Preliminary Drawing
NOT CHECKED!
DATE: 05/23/95
ABB Flexible Automation

CONVERTED TO NORTH AMERICAN FORMAT
FROM EUROPEAN DOCUMENT NO. 3HAB 2821-5

We reserve all rights in this document and in the information contained therein. Reproduction, use or disclosure to third parties without express authority is strictly forbidden.
ABB 19

3	RE 1651	1995 WIGOS	
DET. NO.	REV. NO.	CHANGE	DATE BY
		TITLE ELECTRICAL DIAGRAM CONTROL SYSTEM S4 M94A ABB PEDESTAL ROBOTS CONNECTIONS FOR ABB ESAB EQUIP.	
DESIGNED BY	DRAWN BY	CHECK BY	SCALE
	RSS		N/A
ABB DRAWING NO.	REV.	SHEET	CONT.
CAB M94A-50013-04	3	13.4 of 43	13.

OPTION 65X

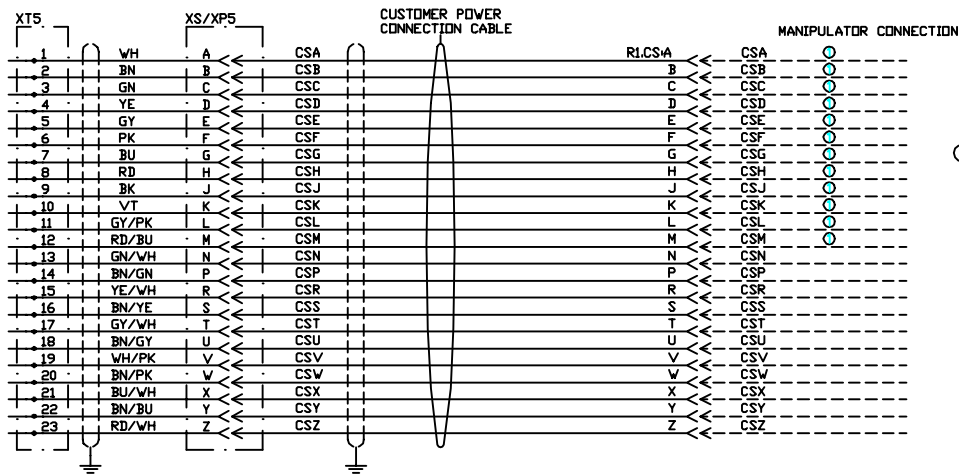
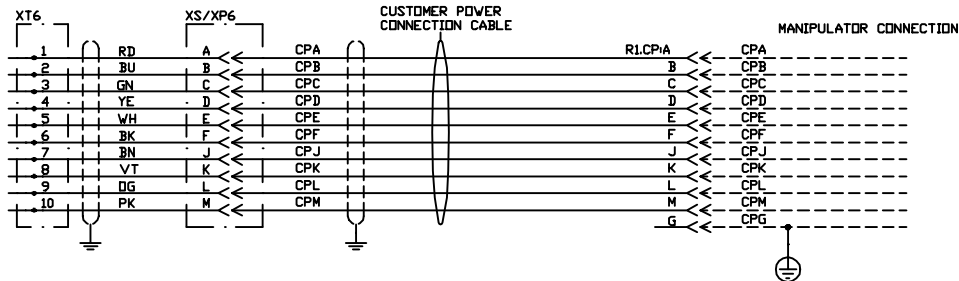

① IRB 1400 IS ONLY EQUIPPED WITH 12 SIGNAL CONNECTIONS.

OPTIONAL CUSTOMER CONNECTIONS, MANIPULATOR

Preliminary Drawing
NOT CHECKED!
DATE: 05/23/95
ABB Flexible Automation

CONVERTED TO NORTH AMERICAN FORMAT
FROM EUROPEAN DOCUMENT No. 3MAB 2821-5

We reserve all rights in this document and in the information contained therein. Reproduction, use or disclosure to third parties without express authority is strictly forbidden.
ABB 19

DET. NO.	REV. NO.	CHANGE	DATE	BY
		TITLE ELECTRICAL DIAGRAM CONTROL SYSTEM S4 M94A ABB PEDESTAL ROBOTS OPT. CUST. CONN., MANIPULATOR		
DESIGNED BY RSS	DRAWN BY RSS	CHECK BY	DATE 05/23/95	SCALE N/A
ABB DRAWING NO. CAB M94A-50013-05	REV. 0	SHEET 43	CONTD. 13.6	

13.6
00

13.6
01

13.6
02

13.6
03

13.6
04

13.6
05

13.6
06

13.6
07

13.6
08

13.6
09

13.6
10

13.6
11

13.6
12

13.6
13

13.6
14

13.6
15

13.6
16

13.6
17

13.6
18

13.6
19

13.6
20

OPTION 7X

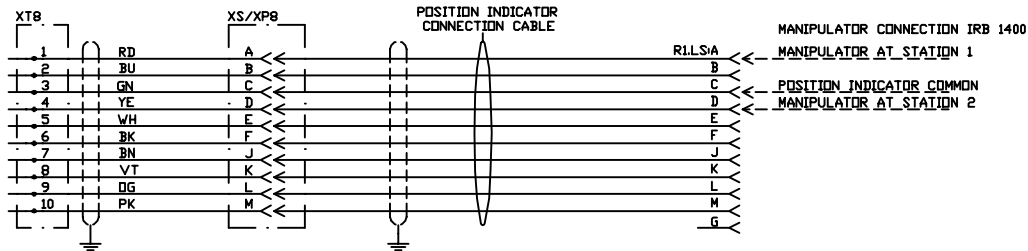

OPTION 7X, 8X, 9X

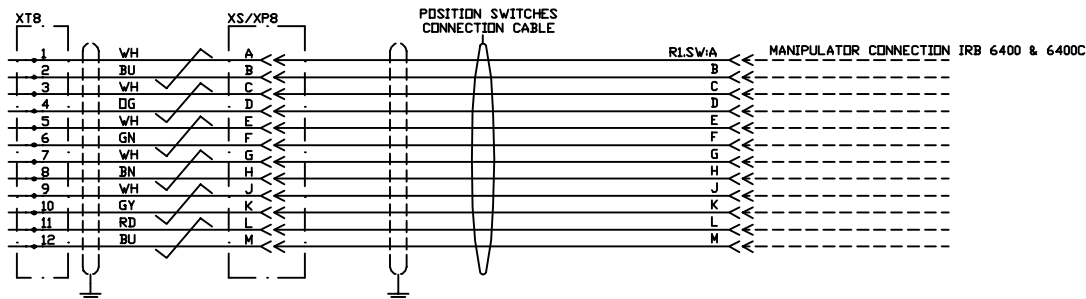

OPTIONAL POSITION SWITCHES ON MANIPULATOR
ABB PEDESTAL ROBOTS IRB 1400, 6400, 6400C

Preliminary Drawing
NOT CHECKED!
DATE: 05/23/95
ABB Flexible Automation

CONVERTED TO NORTH AMERICAN FORMAT
FROM EUROPEAN DOCUMENT No. 3HAB 2821-5

We reserve all rights in this document and in the information contained therein. Reproduction, use or disclosure to third parties without express authority is strictly forbidden.
ABB 19

DET. NO.	REV. NO.	CHANGE	DATE	BY
2	1	RE 1564	1994	WKS/D

ABB Robotec Division
 THE ELECTRICAL DIAGRAM
 CONTROL SYSTEM S4 M94A
 PED. ROBOTS, IRB 1400, 6400, C
 OPT. POS'N. SW. ON MANIPULATOR

DESIGNED BY	DRAWN BY	CHECK BY	DATE	SCALE
RSS			05/23/95	N/A

ABB DRAWING NO.	REV.	SHEET	CONT.
CAB M94A-50013-06	2	13.6 of 43	14

14 00
14 01
14 02
14 03
14 04
14 05
14 06
14 07
14 08
14 09
14 10
14 11
14 12
14 13
14 14
14 15
14 16
14 17
14 18
14 19
14 20

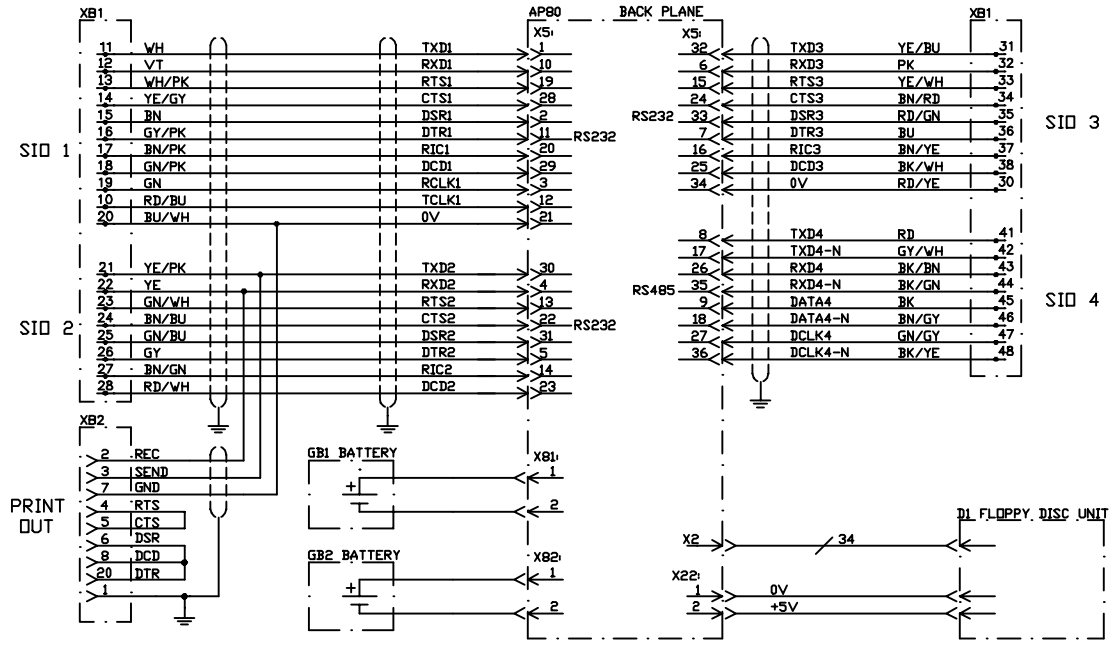

OPTION 411-413
FLOPPY DISC UNIT, DATA PORTS, BATTERIES

Preliminary Drawing
NOT CHECKED!
DATE: 05/23/95
ABB Flexible Automation

CONVERTED TO NORTH AMERICAN FORMAT
FROM EUROPEAN DOCUMENT No. 3HAB 2821-5

We reserve all rights in this document and in the information contained therein. Reproduction, use or disclosure to third parties without express authority is strictly forbidden.
ABB 19

DET. NO.	REV. NO.	CHANGE	DATE	BY
		TITLE ELECTRICAL DIAGRAM CONTROL SYSTEM S4 M94A ABB PEDESTAL ROBOTS FPY. DISC UNIT, DATA PORTS, BATTERIES		
DESIGNED BY RSS	DRAWN BY RSS	CHECK BY	DATE 05/23/95	SCALE N/A
ABB DRAWING NO. CAB M94A-50014-00	REV. 0	SHEET 14	CONT'D. of 4315	

15 00
15 01
15 02
15 03
15 04
15 05
15 06
15 09
15 10
15 11
15 12
15 13
15 14
15 15
15 16
15 17
15 18
15 19
15 20

OPTION 193

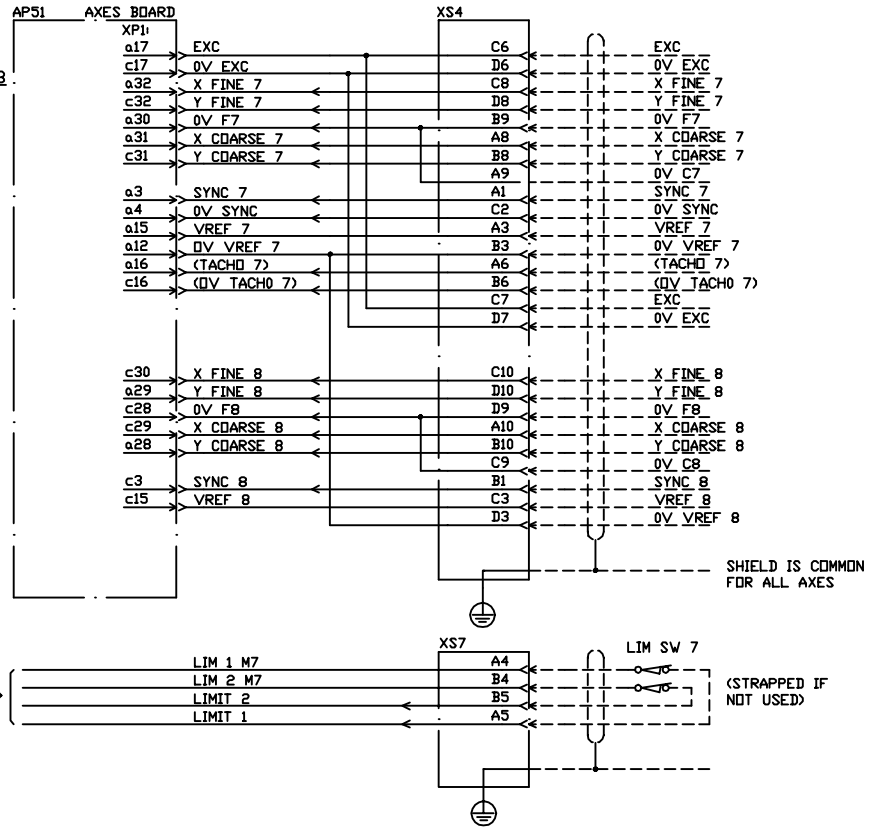

Preliminary Drawing
NOT CHECKED!
DATE: 05/23/95
ABB Flexible Automation

CONVERTED TO NORTH AMERICAN FORMAT
FROM EUROPEAN DOCUMENT No. 3HAB 2821-5

DET. NO.	REV. NO.	CHANGE	DATE	BY
		TITLE ELECTRICAL DIAGRAM CONTROL SYSTEM S4 M94A ABB PEDESTAL ROBOTS EXTERNAL AXES 7-8		
DESIGNED BY	DRAWN BY	CHECK BY	DATE	SCALE
ABB DRAWING NO.	REV.	SHEET	CONT.	N/A
CAB M94A-50015-00	0	15	of 43	16

We reserve all rights in this document and in the information contained therein. Reproduction, use or disclosure to third parties without express authority is strictly forbidden.
ABB 19

- 15 00
- 15 01
- 15 02
- 15 03
- 15 04
- 15 05
- 15 06
- 15 06
- 15 07
- 15 08
- 15 09
- 15 10
- 15 11
- 15 12
- 15 13
- 15 14
- 15 15
- 15 16
- 15 17
- 15 18
- 15 19
- 15 20

OPTION 193

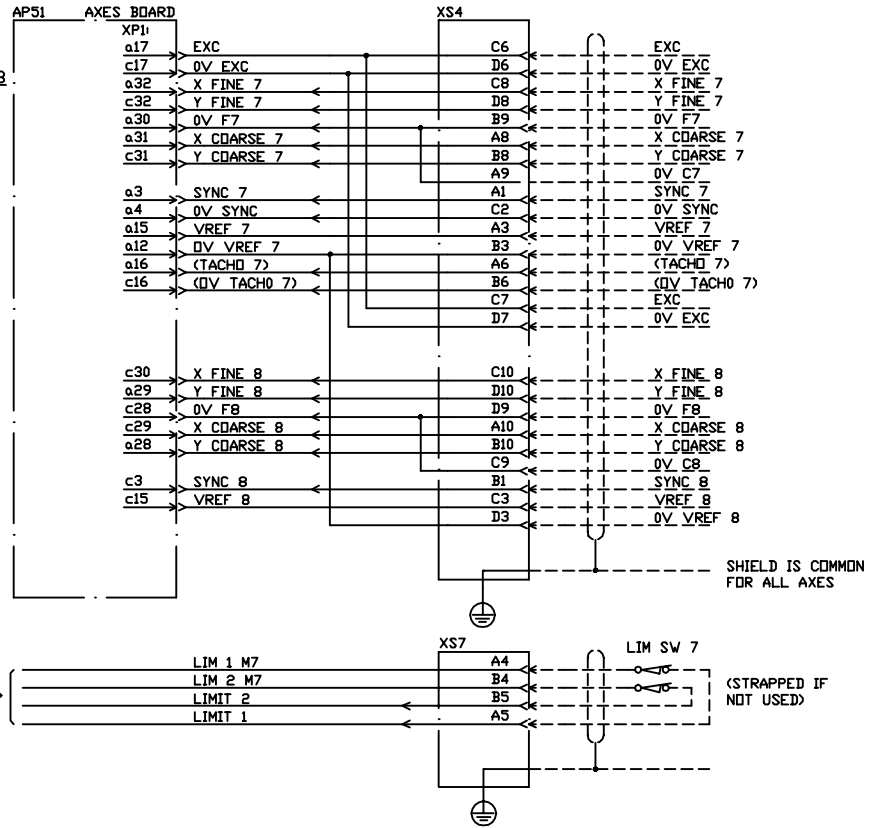

08 16

Preliminary Drawing
 NOT CHECKED!
 DATE: 05/23/95
 ABB Flexible Automation

CONVERTED TO NORTH AMERICAN FORMAT
 FROM EUROPEAN DOCUMENT No. 3HAB 2821-5

DET. NO.	REV. NO.	CHANGE	DATE	BY
DESIGNED BY		DRAWN BY	CHECK BY	DATE
ABB DRAWING NO.		REV.	SHEET	CONT.
CAB M94A-50015-00		0	15	4316

We reserve all rights in this document and in the information contained therein. Reproduction, use or disclosure to third parties without express authority is strictly forbidden.
 ABB 19

16 00
16 01
16 02
16 03
16 04
16 05
16 06
16 07
16 08
16 09
16 10
16 11
16 12
16 13
16 14
16 15
16 16
16 17
16 18
16 19
16 20

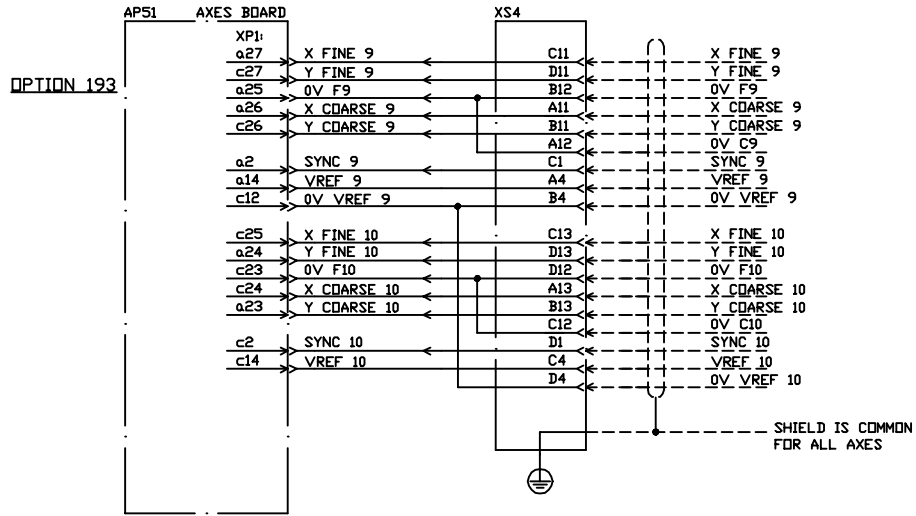

Preliminary Drawing
NOT CHECKED!
DATE: 05/23/95
ABB Flexible Automation

CONVERTED TO NORTH AMERICAN FORMAT
FROM EUROPEAN DOCUMENT No. 3HAB 2821-5

We reserve all rights in this document and in the information contained therein. Reproduction, use or disclosure to third parties without express authority is strictly forbidden. ABB 13

DET. NO.	REV. NO.	CHANGE	DATE	BY

ABB
ABB BROWN BOXPAC
Robotics Division

TITLE: ELECTRICAL DIAGRAM
CONTROL SYSTEM S4 M94A
ABB PEDESTAL ROBOTS
EXTERNAL AXES 9-10

DESIGNED BY	DRAWN BY	CHECK BY	DATE	SCALE
	RSS		05/23/95	N/A

ABB DRAWING NO. CAB M94A-50016-00

REV.	SHEET	CONT.
0	16	of 4317

- 17 00
- 17 01
- 17 02
- 17 03
- 17 04
- 17 05
- 17 06
- 17 07
- 17 08
- 17 09
- 17 10
- 17 11
- 17 12
- 17 13
- 17 14
- 17 15
- 17 16
- 17 17
- 17 18
- 17 19
- 17 20

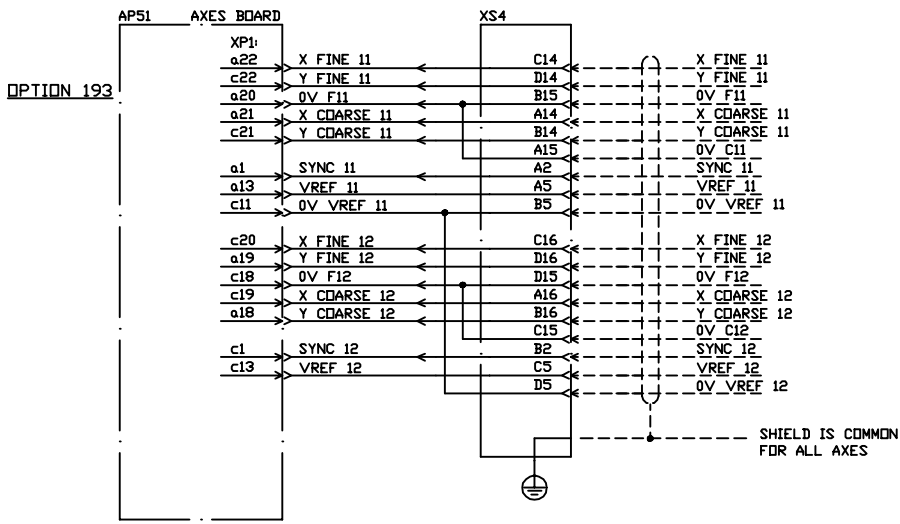

Preliminary Drawing
 NOT CHECKED!
 DATE: 05/23/95
 ABB Flexible Automation

CONVERTED TO NORTH AMERICAN FORMAT
 FROM EUROPEAN DOCUMENT No. 3HAB 2821-5

We reserve all rights in this document and in the information contained therein. Reproduction, use or disclosure to third parties without express authority is strictly forbidden.
 ABB 19

DET. NO.	REV. NO.	CHANGE	DATE	BY

ABB ABB BROWN BOVEN Robotics Division **WPL** ELECTRICAL DIAGRAM
 CONTROL SYSTEM S4 M94A
 ABB PEDESTAL ROBOTS
 EXTERNAL AXES 11-12

DESIGNED BY	DRAWN BY	CHECK BY	DATE	SCALE
	RSS		05/23/95	N/A

ABB DRAWING NO.	REV.	SHEET	CONT.
CAB M94A-50017-00	0	17	of 43

I/O-BOARD POSITION	I/O-BOARD DESIGNATION	I/O TYPE	CUSTOMER CONNECTIONS					INTERNAL I/O SUPPLY OPT. 339	
			EXTERNAL OPT. 31X,38X	SCREW TERMINALS OPT. 34X	RELAY UNIT OPT. 37X	120V AC I/O OPT. 35X	120V AC I/O OPT. 32X	24V I/O	0V
1	AP11	COMBI I/O							
		ANALOGUE PART	XS10	XT10			A7:A		
		DIGITAL PART	XS11	XT11	AP21	AP21	A7:A,A7:B,AP1:A	XT18.13	XT18.5
1	AP11	ANALOGUE	XS10	XT10					
1	AP11	DIGITAL	XS11	XT11	AP21	AP21		XT18.13	XT18.5
2	AP12	DIGITAL	XS12	XT12	AP22	AP22	A7:A, AP1:A	XT18.14	XT18.6
3	AP13	DIGITAL	XS13	XT13	AP23	AP23		XT18.15	XT18.7
4	AP14	DIGITAL	XS14	XT14	AP24	AP24		XT18.16	XT18.8
5	AP15	DIGITAL	XS15	XT15	AP25	AP25		XT18.29	XT18.21
6	AP16	DIGITAL	XS16	XT16	AP26	AP26		XT18.30	XT18.22
2-6	AP12-16	REMOTE I/O-BOARD	-	XT17					

OPTIONAL I/O BOARDS IN CONTROL SYSTEM S4

Preliminary Drawing
 NOT CHECKED!
 DATE: 05/23/95
 ABB Flexible Automation

CONVERTED TO NORTH AMERICAN FORMAT
 FROM EUROPEAN DOCUMENT No. 3HAB 2821-5

DET. NO.	REV. NO.	CHANGE	DATE	BY
		TITLE ELECTRICAL DIAGRAM CONTROL SYSTEM S4 M94A ABB PEDESTAL ROBOTS I/O BOARD POSITION		
DESIGNED BY	DRAWN BY	CHECK BY	DATE	SCALE
	RSS		05/23/95	N/A
ABB DRAWING NO.	REV.	SHEET	CONTD.	
CAB M94A-50018-00	0	18	of 43	19.1

We reserve all rights in this document and in the information contained therein. Reproduction, use or disclosure to third parties without express authority is strictly forbidden.
 ABB 19

19.1 00
19.1 01
19.1 02
19.1 03
19.1 04
19.1 05
19.1 06
19.1 07
19.1 08
19.1 09
19.1 10
19.1 11
19.1 12
19.1 13
19.1 14
19.1 15
19.1 16
19.1 17
19.1 18
19.1 19
19.1 20

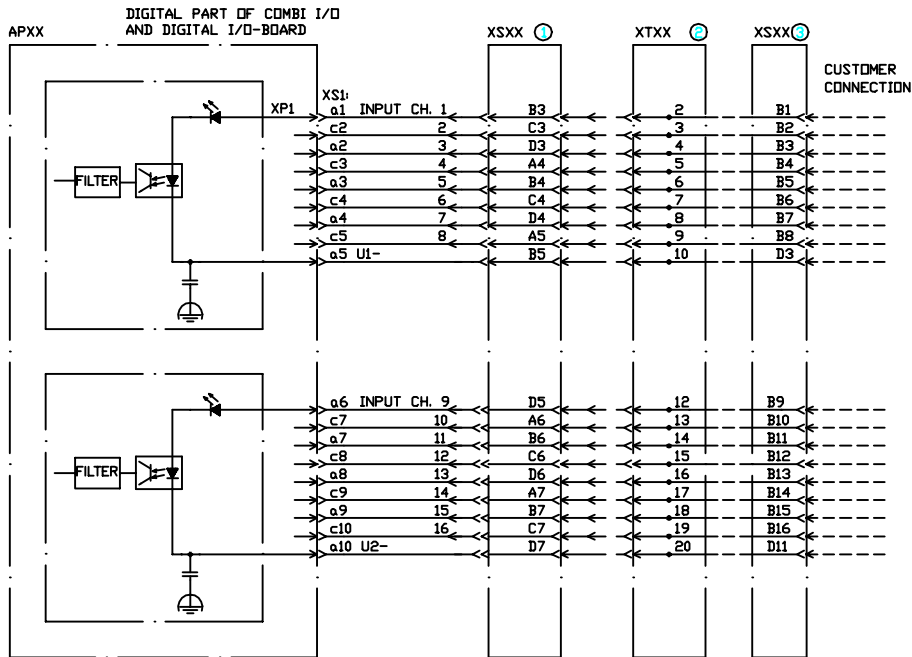

- ① ONLY IF EXTERNAL CONNECTIONS (OPTION 31X).
- ② ONLY IF INTERNAL CONNECTIONS OR SCREW TERMINALS/FLANGE DISCONNECTORS (OPTION 34X).
- ③ ONLY IF EXTERNAL CONNECTIONS AND SCREW TERMINALS (OPTION 38X).

Preliminary Drawing
NOT CHECKED!
DATE: 05/23/95
ABB Flexible Automation

CONVERTED TO NORTH AMERICAN FORMAT
FROM EUROPEAN DOCUMENT No. 3HAB 2821-5

OPTION 20X/238

DIGITAL PART OF COMBI I/O & DIGITAL I/O BOARD INPUT PART

We reserve all rights in this document and in the information contained therein. Reproduction, use or disclosure to third parties without express authority is strictly forbidden.
ABB 19

1	RE 1596	1994	W/C35
DET. NO.	REV. NO.	CHANGE	DATE BY
 ABB ABB SCIENTIFIC Robotics Division			
TITLE ELECTRICAL DIAGRAM CONTROL SYSTEM S4 M94A ABB PEDESTAL ROBOTS DIGITAL I/O BD., COMBI, I/P PART			
DESIGNED BY	DRAWN BY	CHECK BY	DATE
ABB DRAWING NO.	REV.	SHEET	SCALE
CAB M94A-50019-01	1	19.1 of 43	N/A
		CONT'D.	

19.2 00
19.2 01
19.2 02
19.2 03
19.2 04
19.2 05
19.2 06
19.2 07
19.2 08
19.2 09
19.2 10
19.2 11
19.2 12
19.2 13
19.2 14
19.2 15
19.2 16
19.2 17
19.2 18
19.2 19
19.2 20

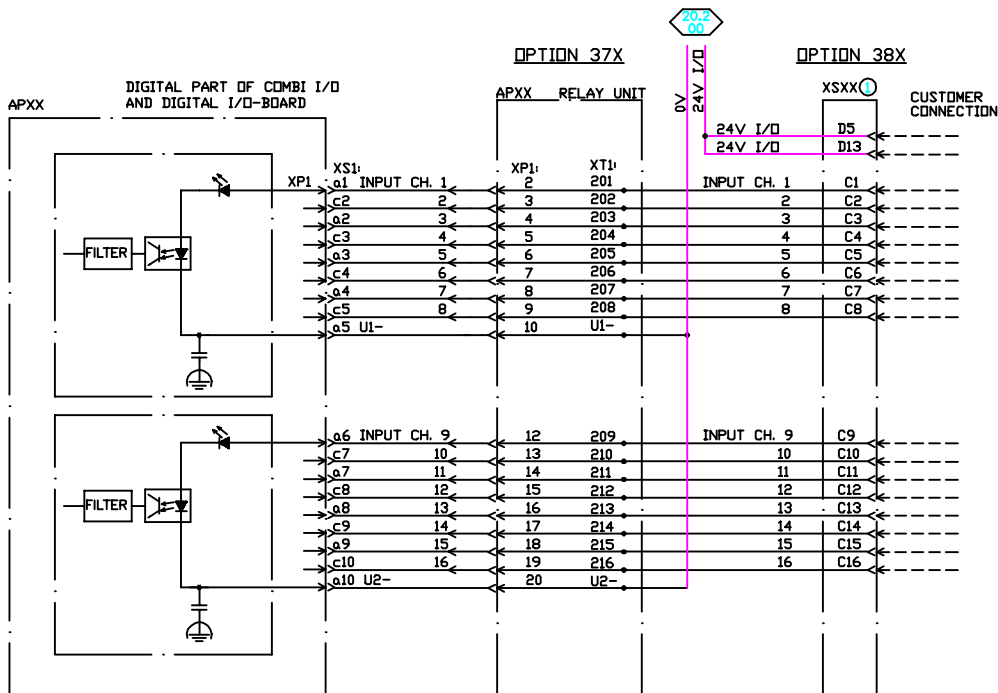

① ONLY IF RELAY UNIT AND INTERNAL I/O-SUPPLY.

Preliminary Drawing
 NOT CHECKED!
 DATE: 05/23/95
 ABB Flexible Automation

CONVERTED TO NORTH AMERICAN FORMAT
 FROM EUROPEAN DOCUMENT No. 3HAB 2821-5

1	RL 1596	CHANGE	1994 WK35	BY
DET. NO.	REV. NO.	DATE		
ABB ABB Flexible Automation Robotics Division		TITLE ELECTRICAL DIAGRAM CONTROL SYSTEM S4 M94A ABB PEDESTAL ROBOTS RELAY UNIT, I/P 1-16		
DESIGNED BY	DRAWN BY	CHKD. BY	DATE	SCALE
	RSS		05/23/95	N/A
ABB DRAWING NO.	REV.	SHEET	CONT.	
CAB M94A-50019-02	1	19.2	of 4319.	

We reserve all rights in this document and in the information contained therein. Reproduction, use or disclosure to third parties without express authority is strictly forbidden. ABB 19

19.3 00
 19.3 01
 19.3 02
 19.3 03
 19.3 04
 19.3 05
 19.3 06
 19.3 07
 19.3 08
 19.3 09
 19.3 10
 19.3 11
 19.3 12
 19.3 13
 19.3 14
 19.3 15
 19.3 16
 19.3 17
 19.3 18
 19.3 19
 19.3 20

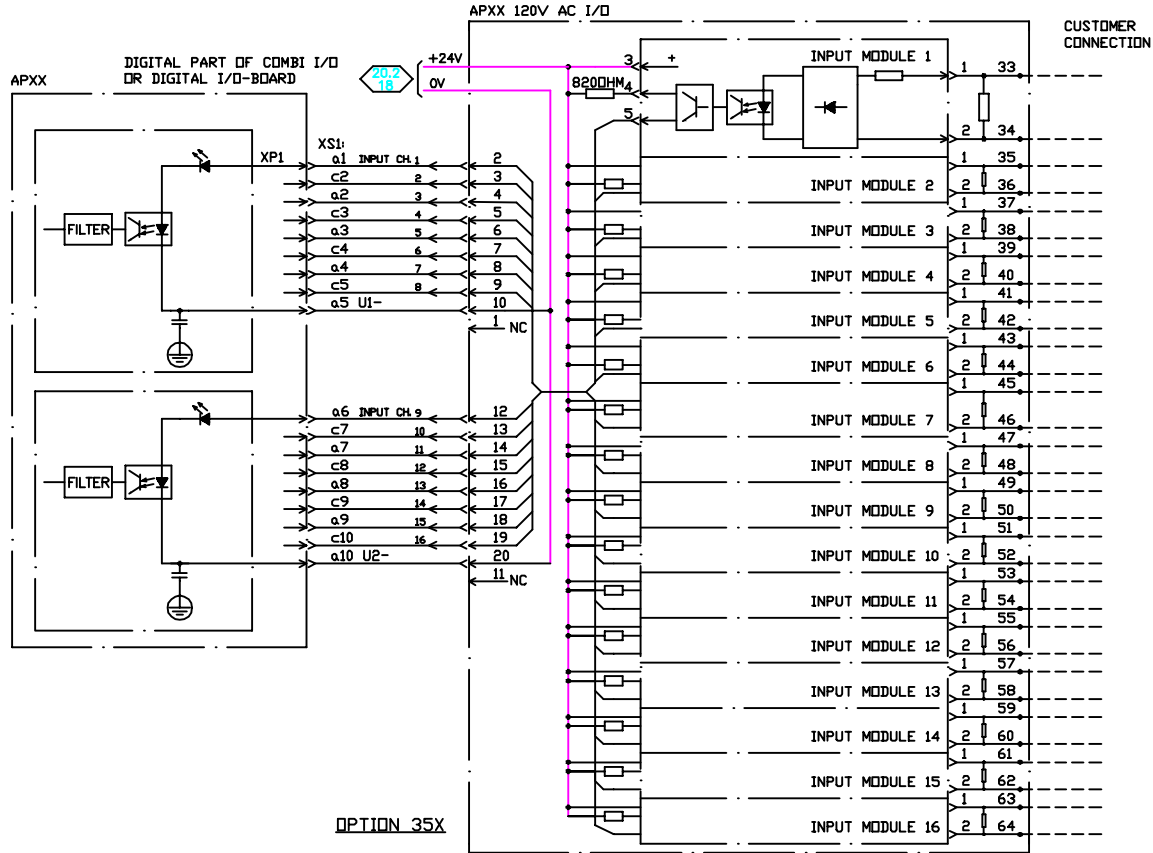

Preliminary Drawing
 NOT CHECKED!
 DATE: 05/23/95
 ABB Flexible Automation

CONVERTED TO NORTH AMERICAN FORMAT
 FROM EUROPEAN DOCUMENT NO. 3HAB 2821-5

We reserve all rights in this document and in the information contained therein. Reproduction, use or disclosure to third parties without express authority is strictly forbidden.
 ABB 19

DET. NO.	REV. NO.	CHANGE	DATE	BY

ABB ABB Inverter Drives Robotics Division

TITLE: ELECTRICAL DIAGRAM
 CONTROL SYSTEM S4 M94A
 ABB PEDESTAL ROBOTS
 120VAC INPUT

DESIGNED BY	DRAWN BY	CHECK BY	DATE	SCALE
RSS			05/23/95	N/A

ABB DRAWING NO.	REV.	SHEET	CONT.
CAB M94A-50019-03	0	19.3 of 43	19.3

- 19.4 00
- 19.4 01
- 19.4 02
- 19.4 03
- 19.4 04
- 19.4 05
- 19.4 06
- 19.4 07
- 19.4 08
- 19.4 09
- 19.4 10
- 19.4 11
- 19.4 12
- 19.4 13
- 19.4 14
- 19.4 15
- 19.4 16
- 19.4 17
- 19.4 18
- 19.4 19
- 19.4 20

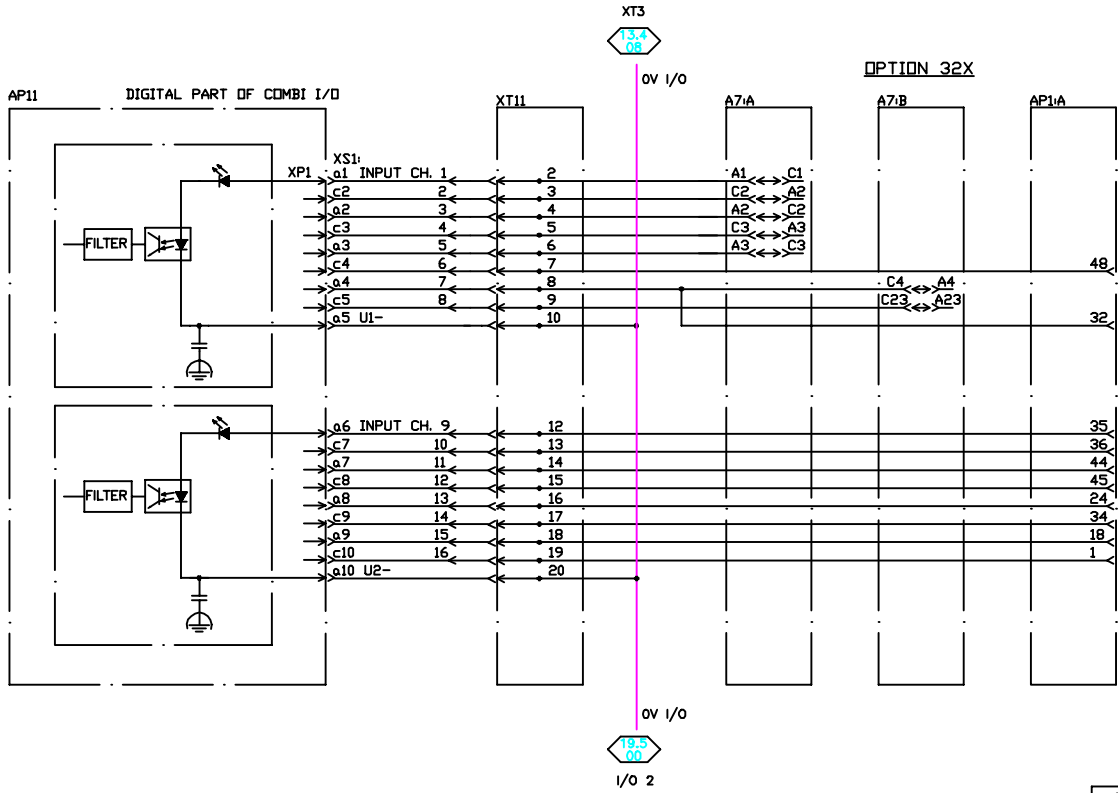

OPTION 32X

Preliminary Drawing
 NOT CHECKED!
 DATE: 05/23/95
 ABB Flexible Automation

CONVERTED TO NORTH AMERICAN FORMAT
 FROM EUROPEAN DOCUMENT No. 3HAB 2821-5

DIGITAL PART OF COMBI I/O. INPUT PART

DET. NO.	REV. NO.	CHANGE	DATE	BY
		TITLE ELECTRICAL DIAGRAM CONTROL SYSTEM S4 M94A ABB PEDESTAL ROBOTS DIG. PART OF COMBI I/O, I/P PART		
DESIGNED BY	DRWN BY	CHKD BY	DATE	SCALE
RSS			05/23/95	N/A
ABB DRAWING NO.	REV.	SHEET	CONTD.	
CAB M94A-50019-04	0	19.4 of 43	19.5	

We reserve all rights in this document and in the information contained therein. Reproduction, use or disclosure to third parties without express authority is strictly forbidden.
 ABB 19

19.5
00

19.5
01

19.5
02

19.5
03

19.5
04

19.5
05

19.5
06

19.5
07

19.5
08

19.5
09

19.5
10

19.5
11

19.5
12

19.5
13

19.5
14

19.5
15

19.5
16

19.5
17

19.5
18

19.5
19

19.5
20

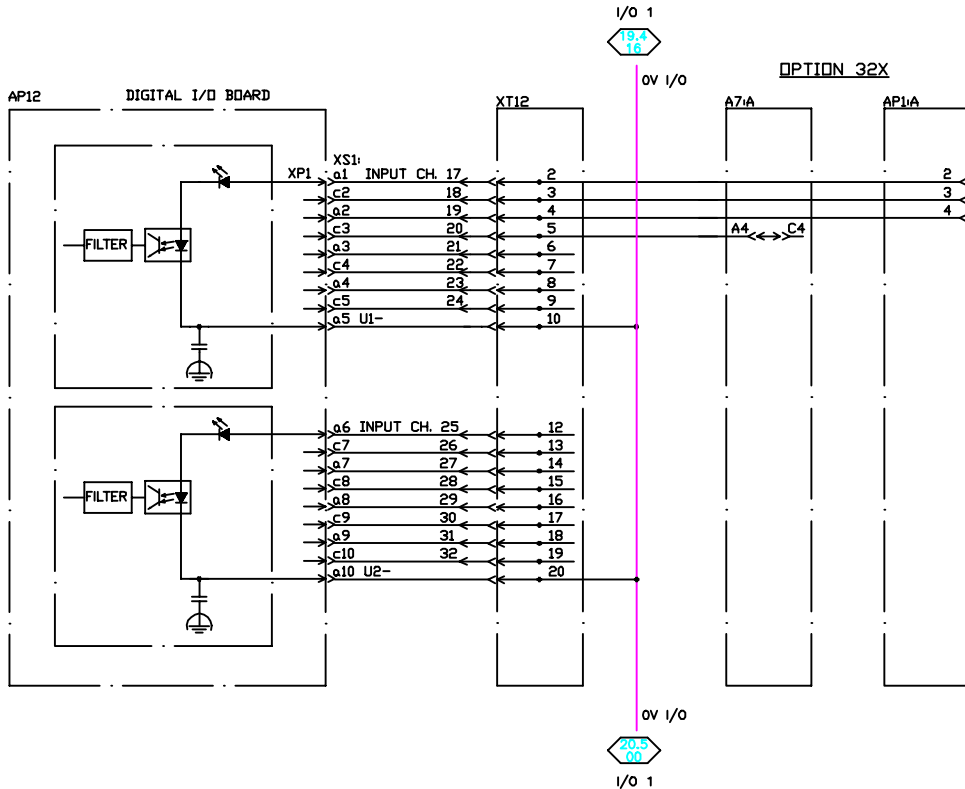

OPTION 32X

Preliminary Drawing
 NOT CHECKED!
 DATE: 05/23/95
 ABB Flexible Automation

CONVERTED TO NORTH AMERICAN FORMAT
 FROM EUROPEAN DOCUMENT No. 3HAB 2821-5

We reserve all rights in this document and in the information contained therein. Reproduction, use or disclosure to third parties without express authority is strictly forbidden.
 ABB 19

DET. NO.	REV. NO.	CHANGE	DATE	BY
ABB <small>ABB BROWN BOYD Robotics Division</small>				
TITLE ELECTRICAL DIAGRAM CONTROL SYSTEM S4 M94A ABB PEDESTAL ROBOTS DIGITAL I/O BOARD, INPUT PART				
DESIGNED BY	DRAWN BY	CHECK BY	DATE	SCALE
	RSS		05/23/95	N/A
ABB DRAWING NO.	REV.	SHEET	CONT'D.	
CAB M94A-50019-05	0	19.5 of 43	20.1	

20.1 00
20.1 01
20.1 02
20.1 03
20.1 04
20.1 05
20.1 06
20.1 07
20.1 08
20.1 09
20.1 10
20.1 11
20.1 12
20.1 13
20.1 14
20.1 15
20.1 16
20.1 17
20.1 18
20.1 19
20.1 20

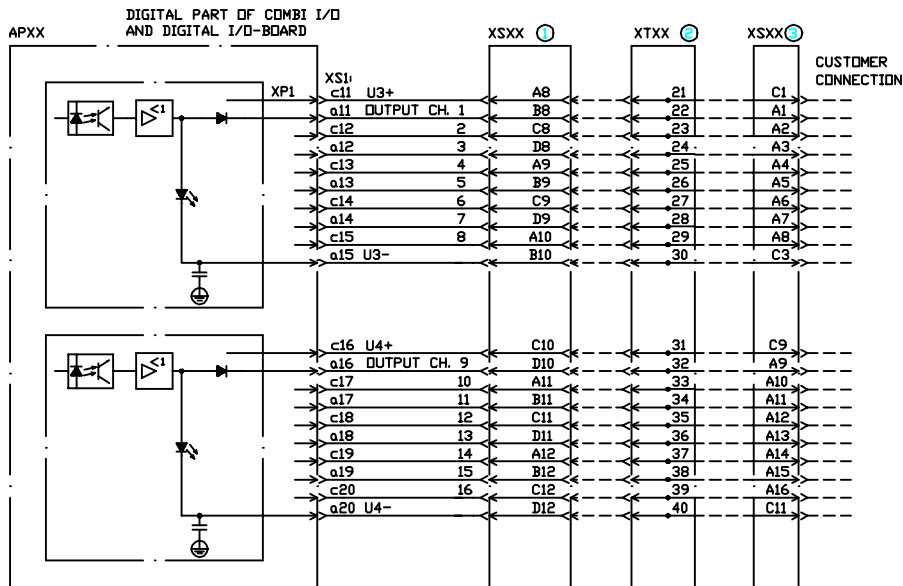

- ① ONLY IF EXTERNAL CONNECTIONS (OPT. 31X).
- ② ONLY IF INTERNAL CONNECTIONS OR SCREW TERMINALS/FLANGE DISCONNECTORS (OPT. 34X).
- ③ ONLY IF EXTERNAL CONNECTIONS AND SCREW TERMINALS (OPT. 38X).

Preliminary Drawing
NOT CHECKED!
DATE: 05/23/95
ABB Flexible Automation

CONVERTED TO NORTH AMERICAN FORMAT
FROM EUROPEAN DOCUMENT No. 3HAB 2821-5

OPTION 20X/23B

DIGITAL PART OF COMBI I/O & DIGITAL I/O BOARD, OUTPUT PART

We reserve all rights in this document and in the information contained therein. Reproduction, use or disclosure to third parties without express authority is strictly forbidden.
ABB 19

1	RI 1596	1994	WK35
DET. NO.	REV. NO.	CHANGE	DATE BY
ABB <small>ABB BROWN BOYCE Robotics Division</small>			
TITLE ELECTRICAL DIAGRAM CONTROL SYSTEM S4 M94A ABB PEDESTAL ROBOTS DIG. COMBI, DIG. I/O BD. O/P PART			
DESIGNED BY	DRAWN BY	CHECK BY	DATE
			05/23/95
ABB DRAWING NO.	REV.	SHEET	CONT.
CAB M94A-50020-01	1	20.1 of 43	20.2

20.2 00
 20.2 01
 20.2 02
 20.2 03
 20.2 04
 20.2 05
 20.2 06
 20.2 07
 20.2 08
 20.2 09
 20.2 10
 20.2 11
 20.2 12
 20.2 13
 20.2 14
 20.2 15
 20.2 16
 20.2 17
 20.2 18
 20.2 19
 20.2 20

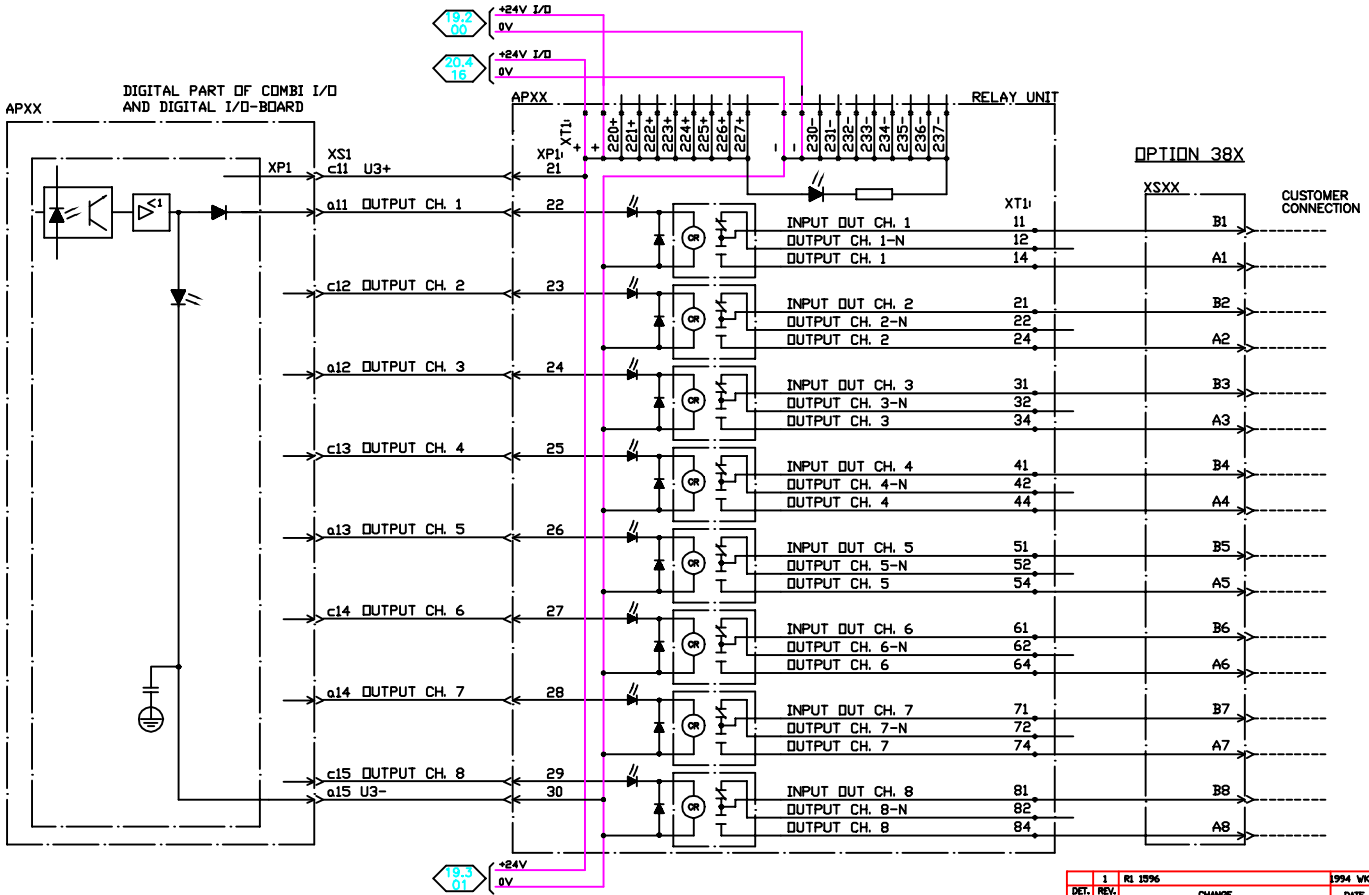

OPTION 37X

OPTION 38X

Preliminary Drawing
 NOT CHECKED!
 DATE: 05/23/95
 ABB Flexible Automation

CONVERTED TO NORTH AMERICAN FORMAT
 FROM EUROPEAN DOCUMENT No. 3HAB 2821-5

We reserve all rights in this document and in the information contained therein. Reproduction, use or disclosure to third parties without express authority is strictly forbidden.
 ABB 19

1	RE 1596	1994 WK35	
DET. NO.	REV. NO.	CHANGE	DATE BY
ABB FILE ELECTRICAL DIAGRAM CONTROL SYSTEM S4 M94A ABB PEDESTAL ROBOTS RELAY UNIT, OUTPUT 1-8 <small>ABB Inverter Supply Robotics Division</small>			
DESIGNED BY	DRAWN BY	CHECK BY	DATE
ABB DRAWING NO.	REV.	SHEET	CONT.
CAB M94A-50020-02	1	20.2	of 43
		SCALE	N/A

20.3 00
 20.3 01
 20.3 02
 20.3 03
 20.3 04
 20.3 05
 20.3 06
 20.3 07
 20.3 08
 20.3 09
 20.3 10
 20.3 11
 20.3 12
 20.3 13
 20.3 14
 20.3 15
 20.3 16
 20.3 17
 20.3 18
 20.3 19
 20.3 20

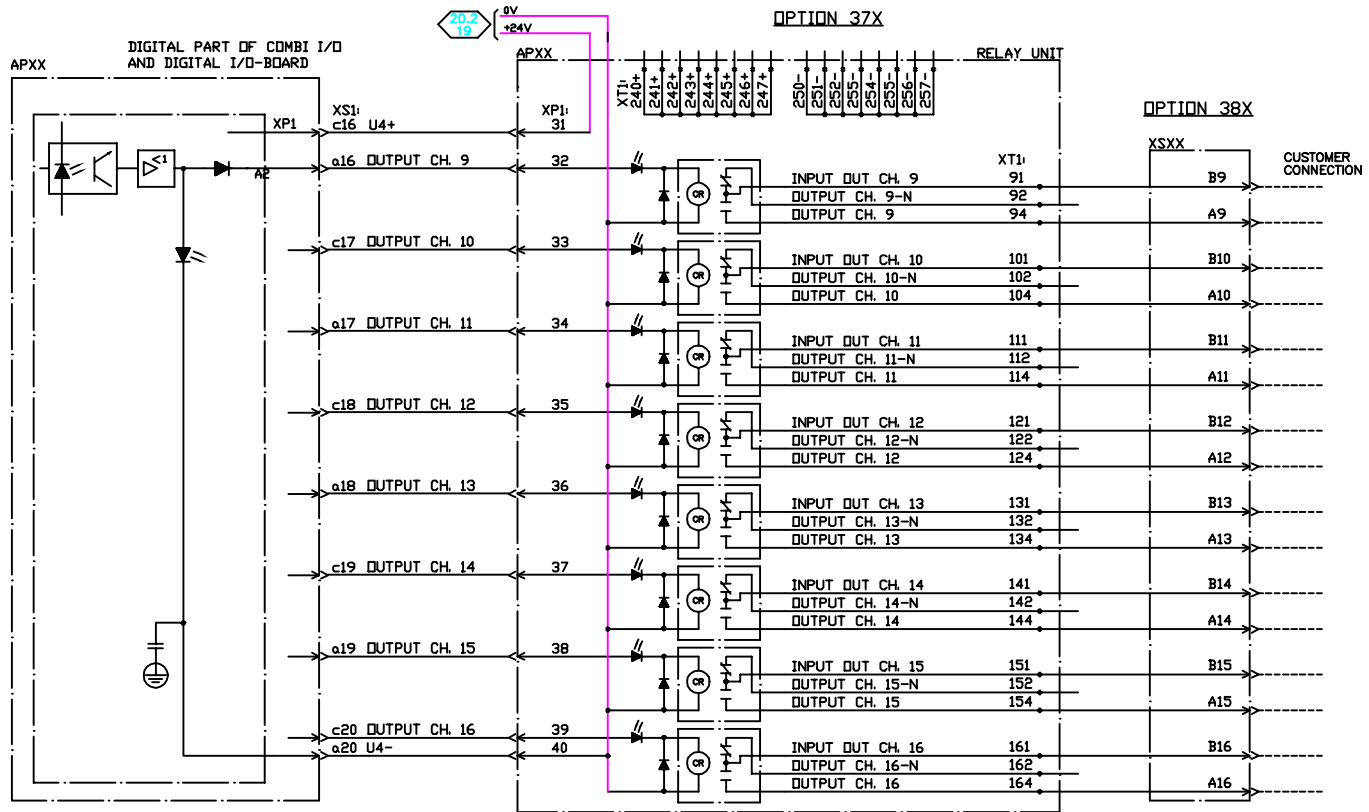

Preliminary Drawing
 NOT CHECKED!
 DATE: 05/23/95
 ABB Flexible Automation

CONVERTED TO NORTH AMERICAN FORMAT
 FROM EUROPEAN DOCUMENT No. 3HAB 2821-3

We reserve all rights in this document and in the information contained therein. Reproduction, use or disclosure in third parties without express authority is strictly forbidden.
 ABB 19

1	RI 1596	1994 WK35		
DET. NO.	REV. NO.	CHANGE	DATE	BY
		WIRING ELECTRICAL DIAGRAM CONTROL SYSTEM S4 M94A ABB PEDESTAL ROBOTS RELAY UNIT, OUTPUT 9-16		
DESIGNED BY	DRAWN BY	CHECK BY	DATE	SCALE
RSS			05/23/95	N/A
ABB DRAWING NO.	REV.	SHEET	CONT.	
CAB M94A-50020-03	1	20.3	of 43	20.4

20.4 00
20.4 01
20.4 02
20.4 03
20.4 04
20.4 05
20.4 06
20.4 07
20.4 08
20.4 09
20.4 10
20.4 11
20.4 12
20.4 13
20.4 14
20.4 15
20.4 16
20.4 17
20.4 18
20.4 19
20.4 20

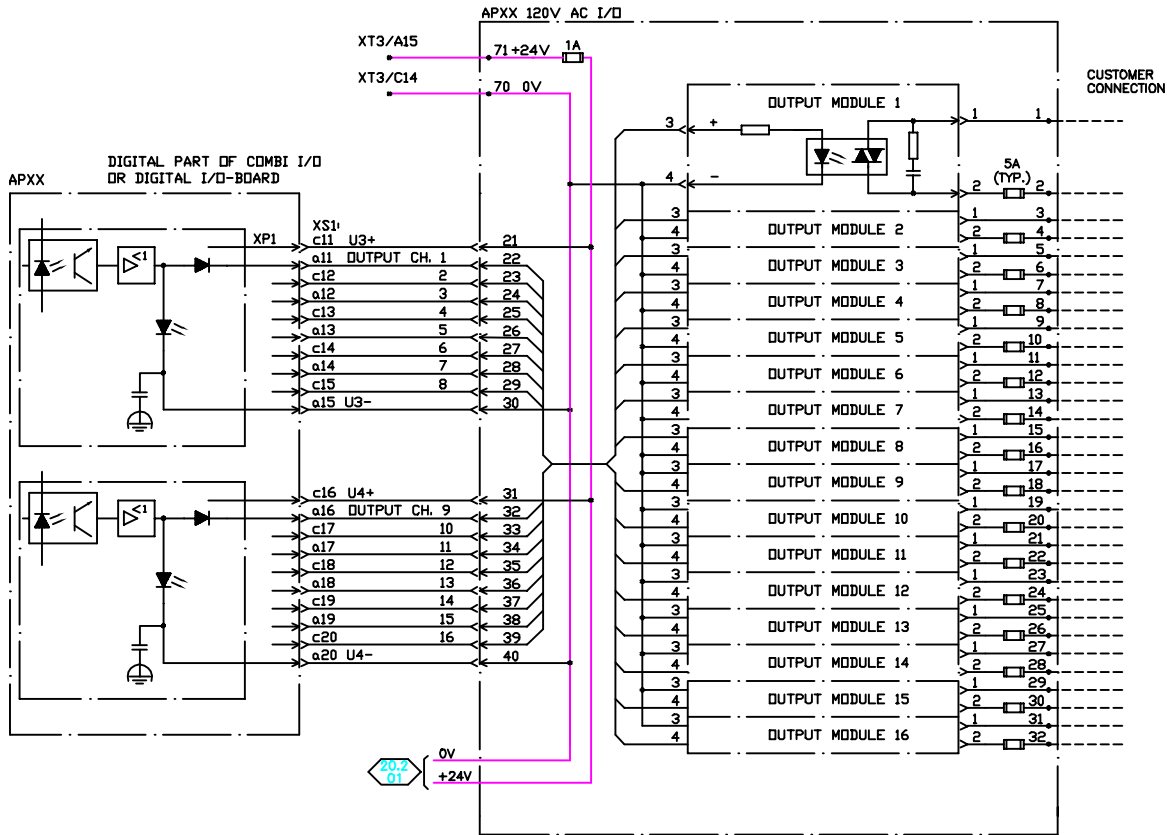

OPTION 35X

Preliminary Drawing
NOT CHECKED!
DATE: 05/23/95
ABB Flexible Automation

CONVERTED TO NORTH AMERICAN FORMAT
FROM EUROPEAN DOCUMENT No. 3HAB 2821-5

We reserve all rights in this document and in the information contained therein. Reproduction, use or disclosure in third parties without express authority is strictly forbidden.
ABB 19

DET. NO.	REV. NO.	CHANGE	DATE	BY
		TITLE ELECTRICAL DIAGRAM CONTROL SYSTEM S4 M94A ABB PEDESTAL ROBOTS 120VAC OUTPUT		
DESIGNED BY	DRWN BY	CHKD BY	DATE	SCALE
RSS			05/23/95	N/A
ABB DRAWING NO.	REV.	SHEET	CONTD.	
CAB M94A-50020-04	0	20.4 of 43	20.5	

20.5 00
 20.5 01
 20.5 02
 20.5 03
 20.5 04
 20.5 05
 20.5 06
 20.5 07
 20.5 08
 20.5 09
 20.5 10
 20.5 11
 20.5 12
 20.5 13
 20.5 14
 20.5 15
 20.5 16
 20.5 17
 20.5 18
 20.5 19
 20.5 20

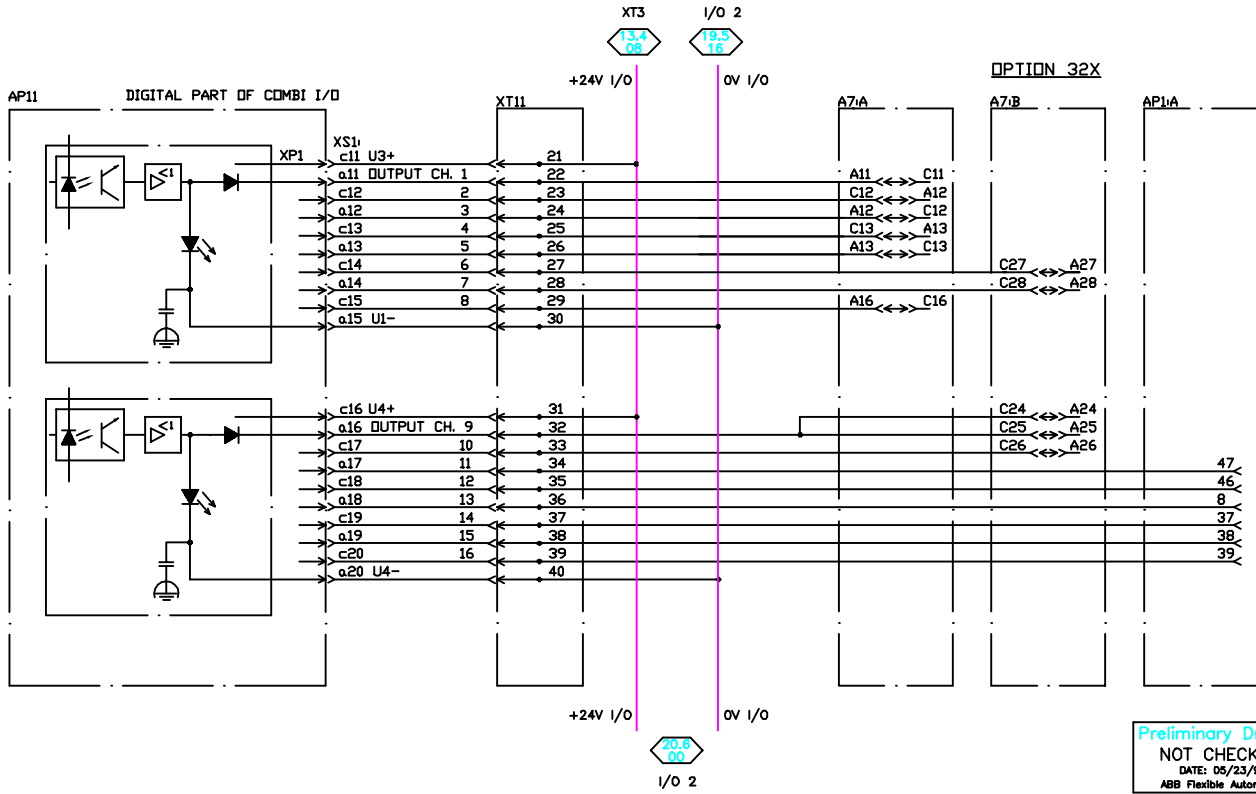

Preliminary Drawing
 NOT CHECKED!
 DATE: 05/23/95
 ABB Flexible Automation

CONVERTED TO NORTH AMERICAN FORMAT
 FROM EUROPEAN DOCUMENT No. 3HAB 2821-5

DIGITAL PART OF COMBI I/O. OUTPUT PART

1	RE 1596	1994 WK35		
DET. NO.	REV. NO.	CHANGE	DATE	BY
		TITLE ELECTRICAL DIAGRAM CONTROL SYSTEM S4 M94A ABB PEDESTAL ROBOTS DIG. PART OF COMBI I/O, O/P PART		
DESIGNED BY	DRAWN BY	CHECK BY	DATE	SCALE
	RSS		05/23/95	N/A
ABB DRAWING NO.	REV.	SHEET	CONTD.	
CAB M94A-50020-05	1	20.5 of 43	20.6	

We reserve all rights in this document and in the information contained therein. Reproduction, use or disclosure to third parties without express authority is strictly forbidden.
 ABB 19

20.6
00
20.6
01
20.6
02
20.6
03
20.6
04
20.6
05
20.6
06
20.6
07
20.6
08
20.6
09
20.6
10
20.6
11
20.6
12
20.6
13
20.6
14
20.6
15
20.6
16
20.6
17
20.6
18
20.6
19
20.6
20

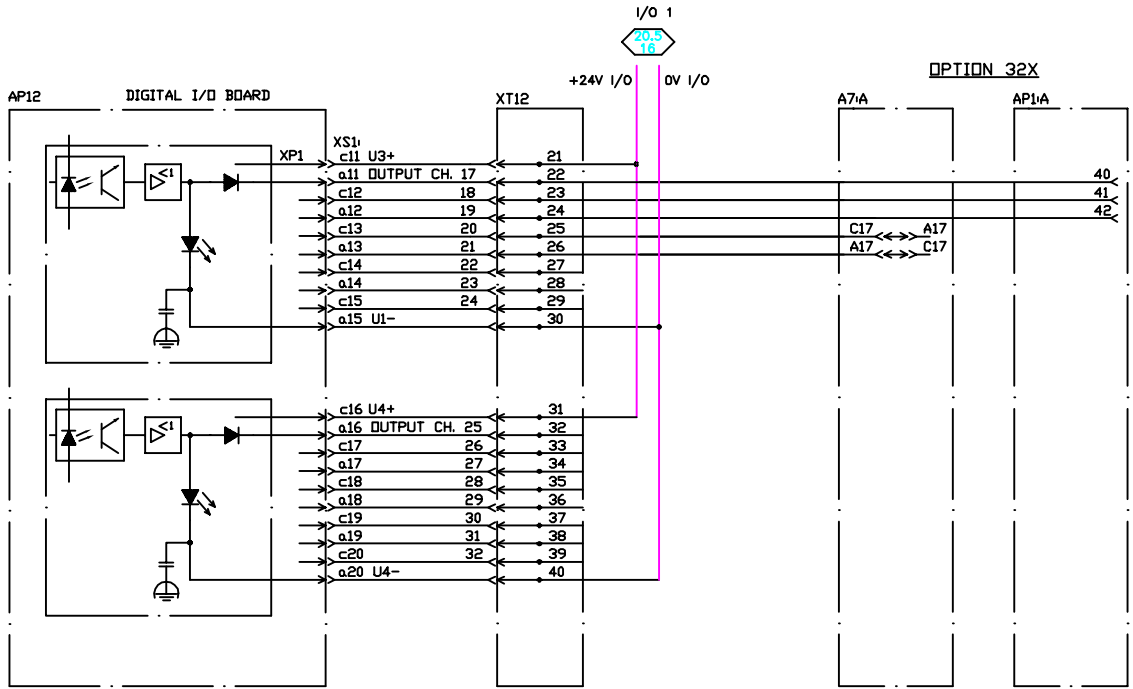

I/O 1
20.6
16

OPTION 32X

Preliminary Drawing
NOT CHECKED!
DATE: 05/23/95
ABB Flexible Automation

CONVERTED TO NORTH AMERICAN FORMAT
FROM EUROPEAN DOCUMENT No. 3HAB 2821-5

1	RI 3596	3994 WK35
DET. NO.	REV. NO.	BY
CHANGE		DATE
ABB <small>ABB Flexible Automation Robotics Division</small>		
TITLE ELECTRICAL DIAGRAM CONTROL SYSTEM S4 M94A ABB PEDESTAL ROBOTS DIGITAL I/O BOARD, OUTPUT PART		
DESIGNED BY	DRAWN BY	CHECKED BY
RSS	RSS	RSS
DATE	SCALE	CONT.
05/23/95	N/A	1
ABB DRAWING NO.	REV.	SHEET
CAB M94A-50020-06	1	20.6 of 43
	CONT.	21.

We reserve all rights in this document and in the information contained therein. Reproduction, use or disclosure to third parties without express authority is strictly forbidden.
ABB 19

OPTION 238

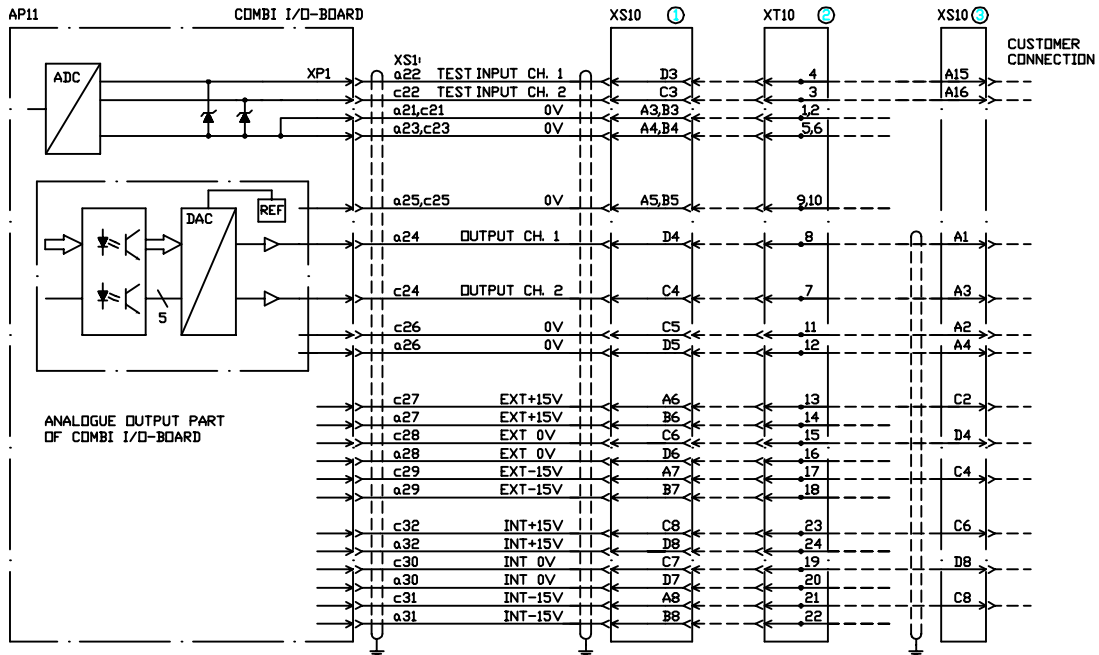

ANALOGUE OUTPUT PART
OF COMBI I/O-BOARD

CUSTOMER
CONNECTION

- ① ONLY IF EXTERNAL CONNECTIONS (OPTION 31X).
- ② ONLY IF SCREW TERMINALS/FLANGE DISCONNECTORS (OPTION 34X).
- ③ ONLY IF EXTERNAL CONNECTIONS AND SCREW TERMINALS (OPTION 38X).

Preliminary Drawing
NOT CHECKED!
DATE: 05/23/95
ABB Flexible Automation

CONVERTED TO NORTH AMERICAN FORMAT
FROM EUROPEAN DOCUMENT No. 3HAB 2821-5

COMBI I/O BOARD ANALOGUE OUTPUT PART

1	RI 1596	1994	WIC35
DET. NO.	REV. NO.	CHANGE	DATE BY
TITLE ELECTRICAL DIAGRAM CONTROL SYSTEM S4 M94A ABB PEDESTAL ROBOTS COMBI I/O BD. ANALOG. O/P PART			
DESIGNED BY	DRAWN BY	CHECK BY	DATE
			05/23/95
ABB DRAWING NO.	REV.	SHEET	CONT.
CAB M94A-50021-01	1	21.1	of 43 21.2

We reserve all rights in this document and in the information contained therein. Reproduction, use or disclosure to third parties without express authority is strictly forbidden.
ABB 19

- 21.1 00
- 21.1 01
- 21.1 02
- 21.1 03
- 21.1 04
- 21.1 05
- 21.1 06
- 21.1 07
- 21.1 08
- 21.1 09
- 21.1 10
- 21.1 11
- 21.1 12
- 21.1 13
- 21.1 14
- 21.1 15
- 21.1 16
- 21.1 17
- 21.1 18
- 21.1 19
- 21.1 20

OPTION 32X

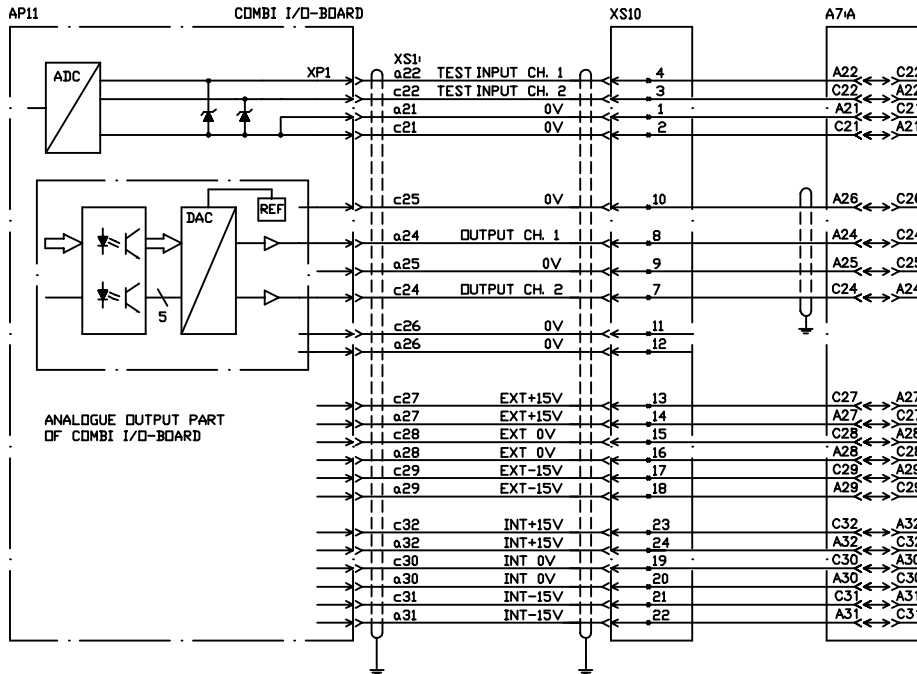

Preliminary Drawing
 NOT CHECKED!
 DATE: 05/23/95
 ABB Flexible Automation

CONVERTED TO NORTH AMERICAN FORMAT
 FROM EUROPEAN DOCUMENT No. 3HAB 2821-5

COMBI I/O BOARD ANALOGUE OUTPUT PART

1	RI 1596	1994	WIC35
DET. NO.	REV. NO.	CHANGE	DATE BY
<p>ABB <small>ABB BROWN BOYCE Robotics Division</small></p> <p>WIR. ELECTRICAL DIAGRAM CONTROL SYSTEM S4 M94A ABB PEDESTAL ROBOTS COMBI I/O BD. ANALOG. O/P PART</p>			
DESIGNED BY	DRAWN BY	CHECK BY	DATE SCALE
ABB DRAWING NO.	REV.	SHEET	CONT.
CAB M94A-50021-02	1	21.2 of 43	22

We reserve all rights in this document and in the information contained therein. Reproduction, use or disclosure to third parties without express authority is strictly forbidden.
 ABB 19

- 21.2 00
- 21.2 01
- 21.2 02
- 21.2 03
- 21.2 04
- 21.2 05
- 21.2 06
- 21.2 07
- 21.2 08
- 21.2 09
- 21.2 10
- 21.2 11
- 21.2 12
- 21.2 13
- 21.2 14
- 21.2 15
- 21.2 16
- 21.2 17
- 21.2 18
- 21.2 19
- 21.2 20

22 00
22 01
22 02
22 03
22 04
22 05
22 06
22 07
22 08
22 09
22 10
22 11
22 12
22 13
22 14
22 15
22 16
22 17
22 18
22 19
22 20

AP11 ANALOGUE I/O-BOARD

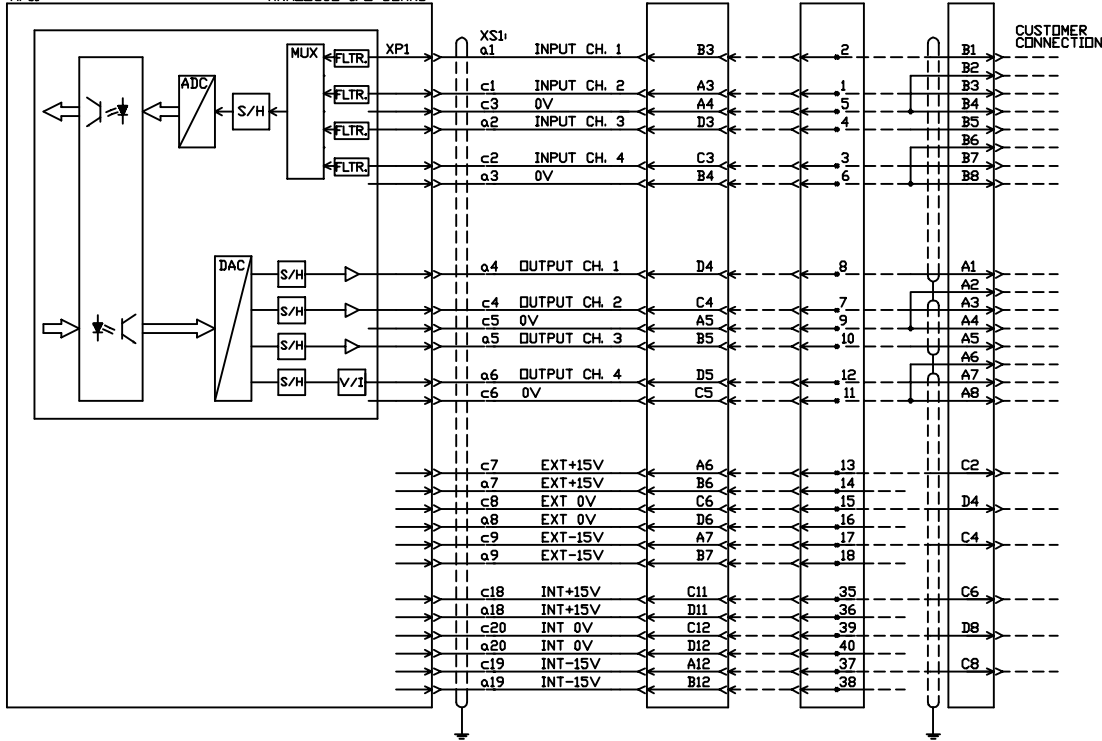

OPTION 227

- ① ONLY IF EXTERNAL CONNECTIONS (OPTION 31X).
- ② ONLY IF SCREW TERMINALS/FLANGE DISCONNECTORS (OPTION 34X).
- ③ ONLY IF EXTERNAL CONNECTIONS AND SCREW TERMINALS (OPTION 38X).

Preliminary Drawing
NOT CHECKED!
DATE: 05/23/95
ABB Flexible Automation

CONVERTED TO NORTH AMERICAN FORMAT
FROM EUROPEAN DOCUMENT No. 3HAB 2821-5

We reserve all rights in this document and in the information contained therein. Reproduction, use or disclosure to third parties without express authority is strictly forbidden.
ABB 19

1	RL 1596	1994 WK.35
DET. NO.	REV. NO.	CHANGE
DATE	DATE	BY
ABB <small>ABB Flexible Automation</small> TITLE: ELECTRICAL DIAGRAM CONTROL SYSTEM S4 M94A ABB PEDESTAL ROBOTS ANALOGUE I/O BOARD		
DESIGNED BY	DRAWN BY	CHKD. BY
ABB DRAWING NO.	REV.	SHEET
CAB M94A-50022-00	1	22 of 43
		CONTR. N/A

23 00
23 01
23 02
23 03
23 04
23 05
23 06
23 07
23 08
23 09
23 10
23 11
23 12
23 13
23 14
23 15
23 16
23 17
23 18
23 19
23 20

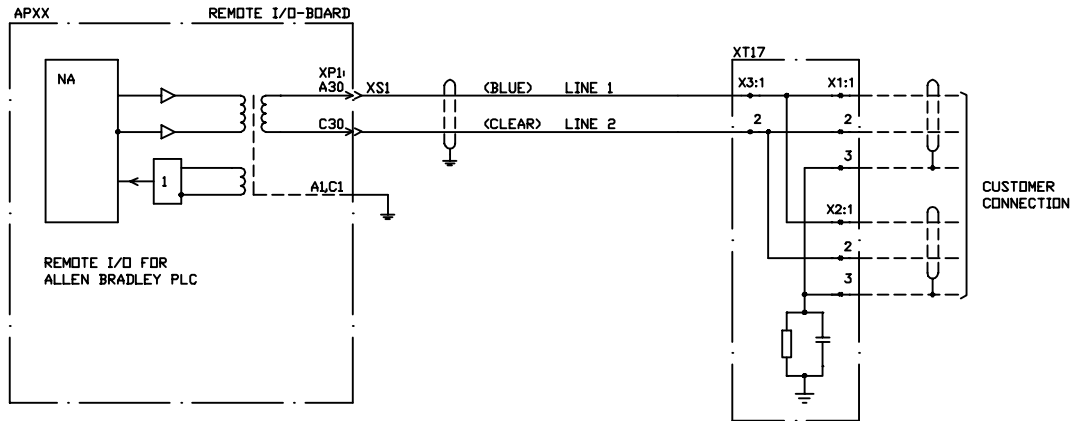

OPTION 241

REMOTE I/O FOR ALLEN-BRADLEY PLC

We reserve all rights in this document and in the information contained therein. Reproduction, use or disclosure in third parties without express authority is strictly forbidden.
ABB 19

DET. NO.	REV. NO.	CHANGE	DATE	BY
		TITLE ELECTRICAL DIAGRAM CONTROL SYSTEM S4 M94A ABB PEDESTAL ROBOTS REMOTE I/O BOARD FOR A-B PLC		
DESIGNED BY	DRAWN BY	CHECK BY	DATE	SCALE
	RSS		05/23/95	N/A
ABB DRAWING NO.	REV.	SHEET	CONT.	
CAB M94A-50023-00	0	23	of 43 24	

24 00
24 01
24 02
24 03
24 04
24 05
24 06
24 07
24 08
24 09
24 10
24 11
24 12
24 13
24 14
24 15
24 16
24 17
24 18
24 19
24 20

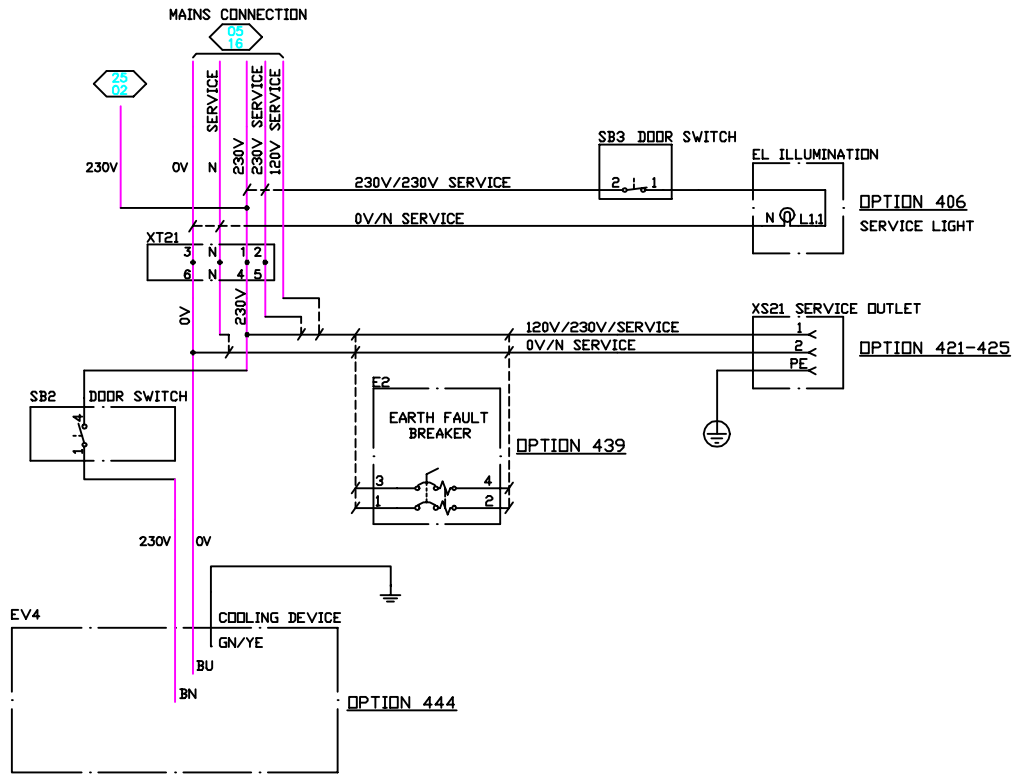

COOLING DEVICE, SERVICE OUTLET, ILLUMINATION (OPTIONS)

Preliminary Drawing
NOT CHECKED!
DATE: 05/23/95
ABB Flexible Automation

CONVERTED TO NORTH AMERICAN FORMAT
FROM EUROPEAN DOCUMENT No. 3HAB 2821-5

DESIGNED BY	DRAWN BY	CHECK BY	DATE	SCALE
	RSS		05/23/95	N/A
ABB DRAWING NO.		SHEET CONT.		
CAB M94A-50024-00		2 of 4325		

DET. NO.	REV. NO.	CHANGE	DATE	BY

We reserve all rights in this document and in the information contained therein. Reproduction, use or disclosure to third parties without express authority is strictly forbidden.
ABB 19

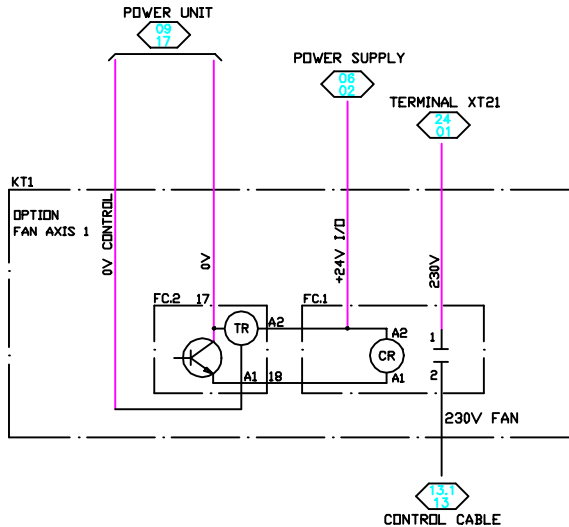

OPTION 5X

OPTIONAL FAN, AXIS 1 MANIPULATOR, TIME DELAY, CONTACTOR

Preliminary Drawing
 NOT CHECKED!
 DATE: 05/23/95
 ABB Flexible Automation

CONVERTED TO NORTH AMERICAN FORMAT
 FROM EUROPEAN DOCUMENT No. 3HAB 2821-5

DET. NO.	REV. NO.	CHANGE	DATE	BY
 ABB <small>ABB HOME SYSTEM Robotics Division</small>				
TITLE ELECTRICAL DIAGRAM CONTROL SYSTEM S4 M94A ABB PEDESTAL ROBOTS FAN, AXIS 1 ROBOT, TD CONT (OPT.)				
DESIGNED BY	DRAWN BY	CHECK BY	DATE	SCALE
	RSS		05/23/95	N/A
ABB DRAWING NO.	REV.	SHEET	CONT.	
CAB M94A-50025-00	0	25	of 43 26	

We reserve all rights in this document and in the information contained therein. Reproduction, use or disclosure in 3rd parties without express authority is strictly forbidden.
 ABB 19

- 25 00
- 25 01
- 25 02
- 25 03
- 25 04
- 25 05
- 25 06
- 25 07
- 25 08
- 25 09
- 25 10
- 25 11
- 25 12
- 25 13
- 25 14
- 25 15
- 25 16
- 25 17
- 25 18
- 25 19
- 25 20

26 00
26 01
26 02
26 03
26 04
26 05
26 06
26 07
26 08
26 09
26 10
26 11
26 12
26 13
26 14
26 15
26 16
26 17
26 18
26 19
26 20

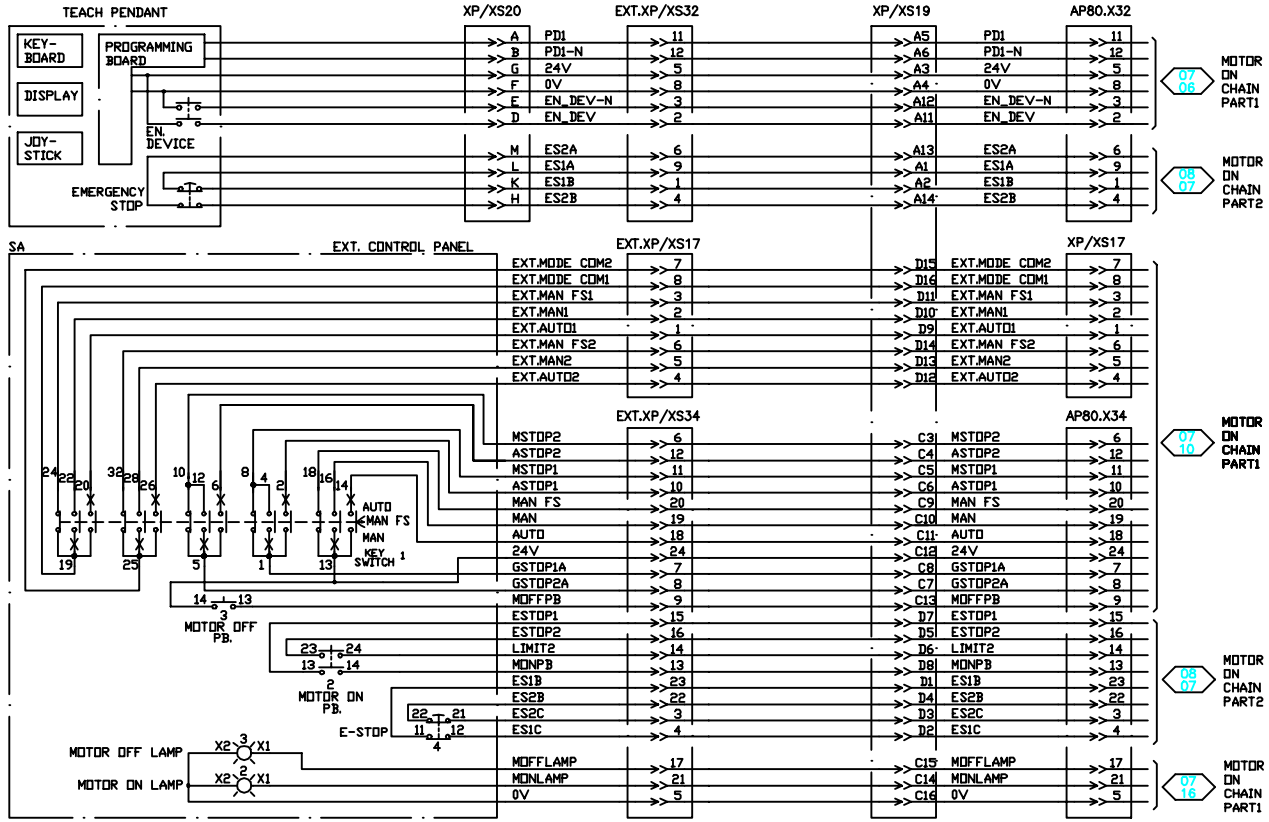

Preliminary Drawing
NOT CHECKED!
DATE: 05/23/95
ABB Flexible Automation

CONVERTED TO NORTH AMERICAN FORMAT
FROM EUROPEAN DOCUMENT No. 3HAB 2821-5

We reserve all rights in this document and in the information contained therein. Reproduction, use or disclosure to third parties without express authority is strictly forbidden.
ABB 19

DET. REV. NO.	CHANGE	DATE	BY

ABB FILE ELECTRICAL DIAGRAM
 ABB Robot System Robotics Division CONTROL SYSTEM S4 M94A
 ABB FEDESTAL ROBOTS
 EXTERNAL CONTROL PANEL OPT. 182

DESIGNED BY	DRAWN BY	CHECK BY	DATE	SCALE	N/A
			05/23/95		

ABB DRAWING NO.	REV.	SHEET	NO.
CAB M94A-50026-00	0	26	43

SHEET NO.	TITLE	DESCRIPTION
101	DRAWING INDEX	
102	CONNECTION POINT LOCATIONS	
103	LEGEND	
104	BRAKE RELEASE UNIT, SERIAL MEASURING BOARD	
105	AXIS 1	
106	AXIS 2	
107	AXIS 3	
108	AXIS 4	
109	AXIS 5	
110	AXIS 6	
111	CUSTOMER POWER CONNECTIONS, FAN (ONLY 2,8PT POKE)	
112	CUSTOMER SIGNAL CONNECTIONS	

VALID FOR:

IRB 6400/2,4-120
 2,4-150
 2,8-100
 3,0-75
 2,8 PT
 POKE
 Mod. M94A

Preliminary Drawing

NOT CHECKED!

DATE: 05/23/95

ABB Flexible Automation

CONVERTED TO NORTH AMERICAN FORMAT
 FROM EUROPEAN DOCUMENT NO. 3HAB 4247-1

We reserve all rights in this document and in the information contained therein. Reproduction, use or disclosure to third parties without express authority is strictly forbidden.
 ABB 19

1	SHT. 304 CHANGED	0995	VL06	AJ
DET. NO.	REV. NO.	CHANGE	DATE	BY
		TITLE ELECTRICAL DIAGRAM S4 M94A ABB PEDESTAL ROBOT - IRB 6400 DRAWING INDEX		
DESIGNED BY	DRAWN BY	CHECK BY	DATE	SCALE
	RSS		05/23/95	N/A
ABB DRAWING NO.	REV.	SHEET	CONT'D.	
ROB 6400-50101-00	1	101 of 12	102	

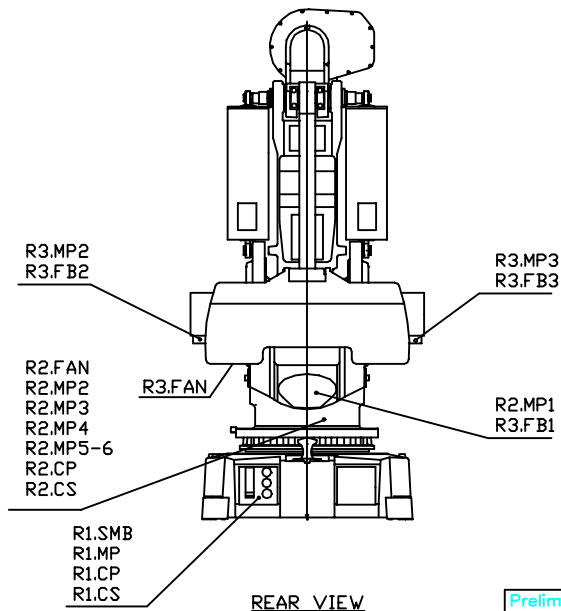
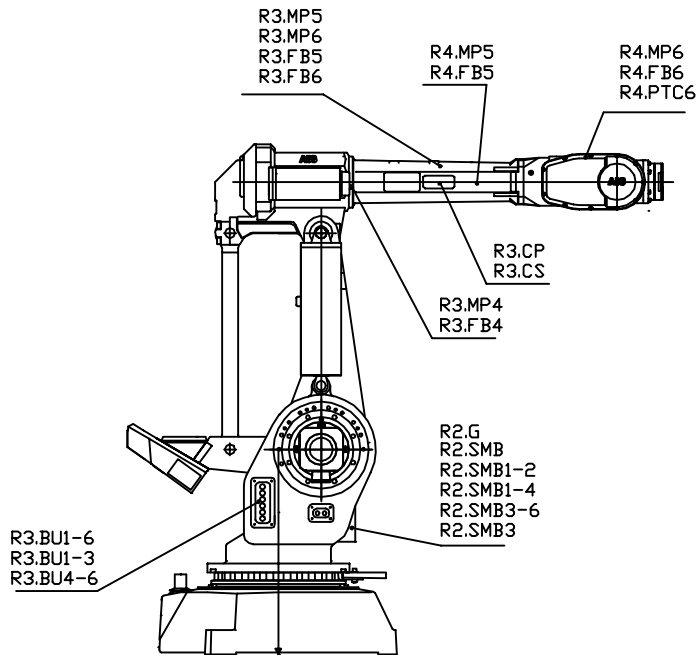





Preliminary Drawing
 NOT CHECKED!
 DATE: 05/23/95
 ABB Flexible Automation

CONVERTED TO NORTH AMERICAN FORMAT
 FROM EUROPEAN DOCUMENT NO. 3HAB 4247-1

We reserve all rights in this document and in the information contained therein. Reproduction, use or disclosure to third parties without express authority is strictly forbidden.
 ABB 10

DET. NO.	REV. NO.	CHANGE	DATE	BY
ABB ABB Inverter Systems Robotics Division		TITLE ELECTRICAL DIAGRAM S4 M94A ABB PEDESTAL ROBOT - IRB 6400 CONNECTION POINT LOCATIONS		
DESIGNED BY	DRAWN BY	CHECKED BY	DATE	SCALE
	RSS		05/23/95	N/A
ABB DRAWING NO.	REV.	SHEET	CONT.	
ROB 6400-50102-00	0	102	of 12 103	

- M MOTOR
- B BRAKE
- PTC TEMP SENSOR (PTC-resistor)
- R RESOLVER
- G BATTERY PACK
- BU BRAKE RELEASE UNIT
- FB FEED-BACK UNIT
- SMB SERIAL MEASURING BOARD
- FAN FAN
-  PROTECTIVE EARTH
-  TWISTED CABLES
-  SHIELDED CABLES
-  OPTIONAL FUNCTIONS
- KEY PIN LOCATION PIN TO AVOID MISMATCH OF CONNECTOR

Preliminary Drawing
 NOT CHECKED!
 DATE: 05/23/95
 ABB Flexible Automation

CONVERTED TO NORTH AMERICAN FORMAT
 FROM EUROPEAN DOCUMENT NO. 3HAB 4247-1

We reserve all rights in this document and in the information contained therein. Reproduction, use or disclosure to third parties without express authority is strictly forbidden.
 ABB 10

DET. NO.	REV. NO.	CHANGE	DATE	BY
		ABB <small>ABB HOME SCIENCE Robotics Division</small>	TITLE ELECTRICAL DIAGRAM S4 M94A ABB PEDESTAL ROBOT - IRB 6400 LEGEND	
DESIGNED BY	DRAWN BY	CHECK BY	DATE	SCALE
	RSS		05/23/95	N/A
ABB DRAWING NO.	REV.	SHEET	CONT.	
ROB 6400-50103-00	0	103 of 12	104	

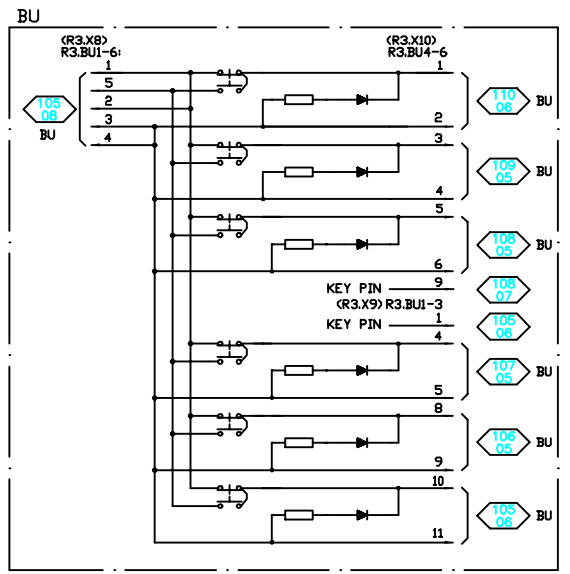
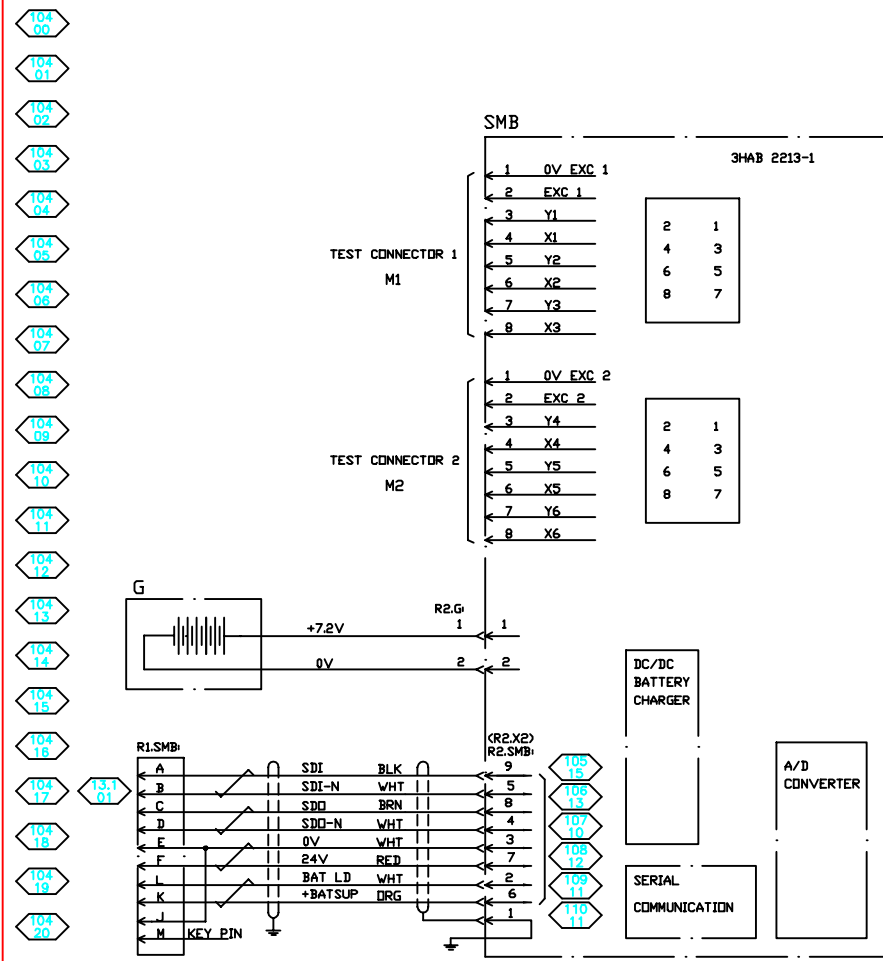

Preliminary Drawing
NOT CHECKED!
DATE: 05/23/95
ABB Flexible Automation

CONVERTED TO NORTH AMERICAN FORMAT
FROM EUROPEAN DOCUMENT NO. 3HAB 4247-1

SHEETS
105-110

We reserve all rights in this document and in the information contained therein. Reproduction, use or disclosure to third parties without express authority is strictly forbidden.
ABB 19

1	KEY PIN ADD. 00	1995 WK06	AJ
1	TEST CONN. 1 & 2 WAS RE JME	1995 WK06	AJ
DEL. NO.	CHANGE	DATE	BY
TITLE ELECTRICAL DIAGRAM S4 M94A ABB PEDESTAL ROBOT - IRB 6400 BRAKE UNIT, SERIAL MEAS. BOARD			
DESIGNED BY	DRAWN BY	CHKD. BY	DATE
ABB DRAWING NO.	RSS	195/23/95	SCALE
1	104	of 12	105

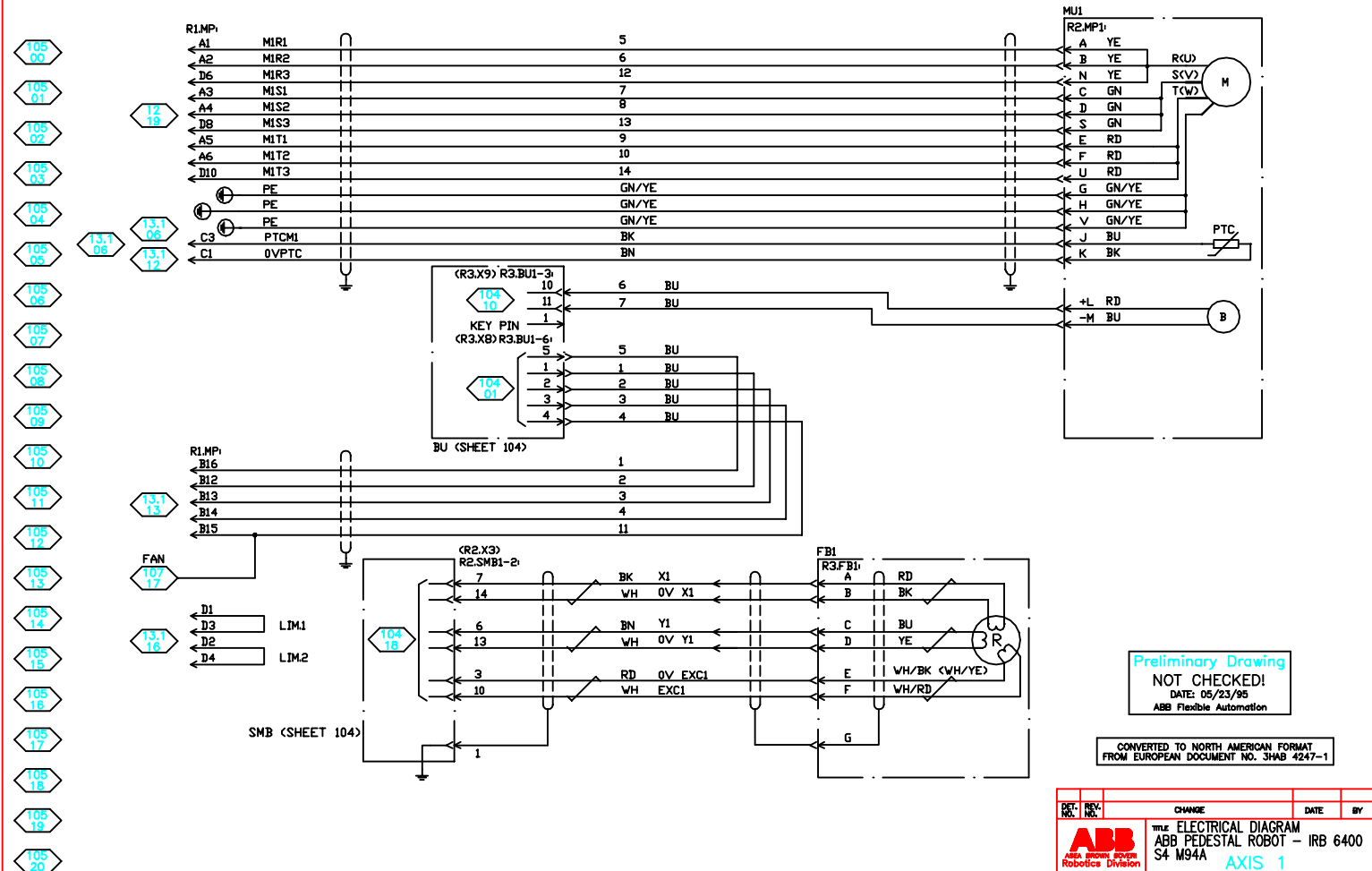

Preliminary Drawing
 NOT CHECKED!
 DATE: 05/23/95
 ABB Flexible Automation

CONVERTED TO NORTH AMERICAN FORMAT
 FROM EUROPEAN DOCUMENT NO. 3HAB 4247-1

DET. NO.	REV. NO.	CHANGE	DATE	BY

ABB
 ABB Inne Scope
 Robotics Division

TITLE ELECTRICAL DIAGRAM
 ABB PEDESTAL ROBOT - IRB 6400
 S4 M94A

AXIS 1

DESIGNED BY	DRAWN BY	CHEK. BY	DATE	SCALE
RSS			05/23/95	N/A

ABB DRAWING NO.	REV.	SHEET	CONT.
RDB 6400-50105-00	0	105 of 12	106

We reserve all rights in this document and in the information contained therein. Reproduction, use or disclosure to third parties without express authority is strictly forbidden.
 ABB 19

106 00
106 01
106 02
106 03
106 04
106 05
106 06
106 07
106 08
106 09
106 10
106 11
106 12
106 13
106 14
106 15
106 16
106 17
106 18
106 19
106 20

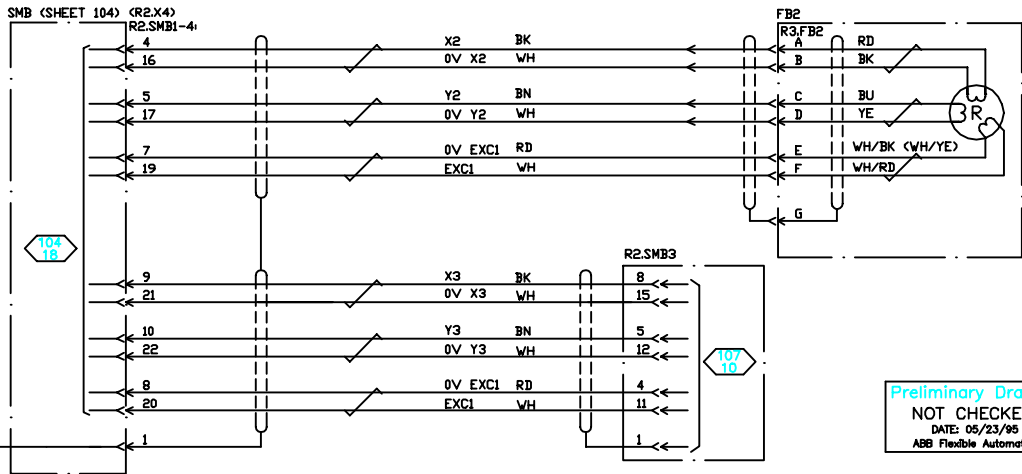
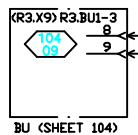
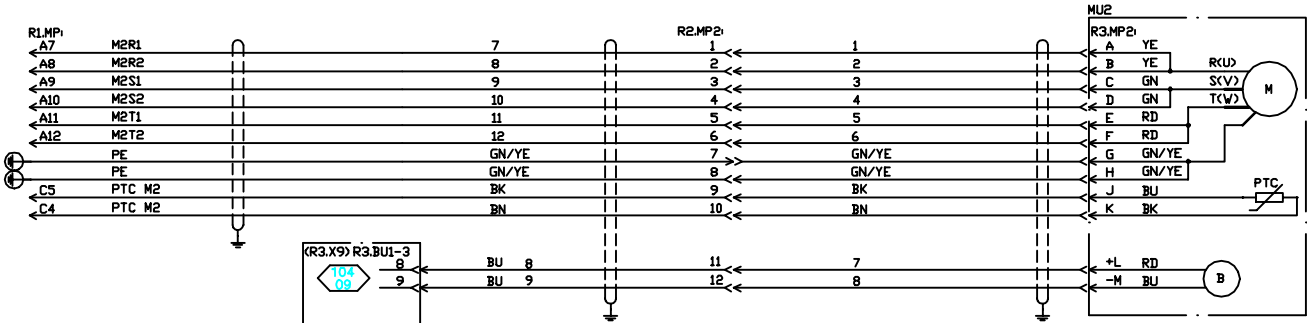

Preliminary Drawing
 NOT CHECKED!
 DATE: 05/23/95
 ABB Flexible Automation

CONVERTED TO NORTH AMERICAN FORMAT
 FROM EUROPEAN DOCUMENT NO. 3HAB 4247-1

We reserve all rights in this document and in the information contained therein. Reproduction, use or disclosure to third parties without express authority is strictly forbidden.
 ABB 19

DET. NO.	REV. NO.	CHANGE	DATE	BY

ABB TITLE ELECTRICAL DIAGRAM
 ABB Flexible Automation Robotics Division
 ABB PEDESTAL ROBOT - IRB 6400
 S4 M94A AXIS 2

DESIGNED BY	DRAWN BY	CHEK. BY	DATE	SCALE
			05/23/95	N/A

ABB DRAWING NO.	REV.	SHEET	CONT.
R0B 6400-50106-00	0	106	of 12

- 107 00
- 107 01
- 107 02
- 107 03
- 107 04
- 107 05
- 107 06
- 107 07
- 107 08
- 107 09
- 107 10
- 107 11
- 107 12
- 107 13
- 107 14
- 107 15
- 107 16
- 107 17
- 107 18
- 107 19
- 107 20

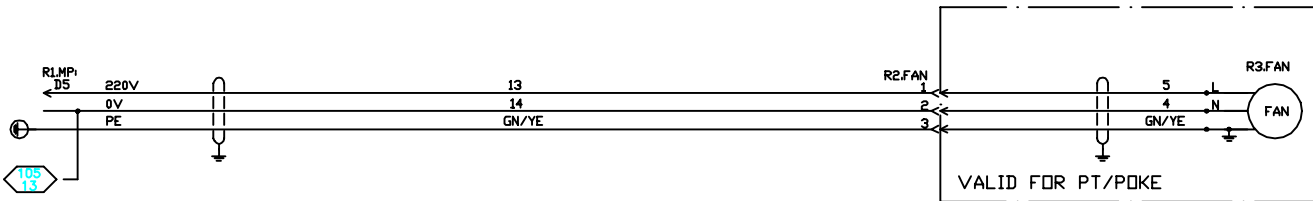
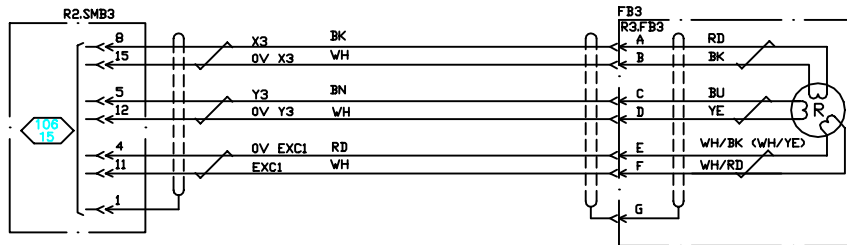
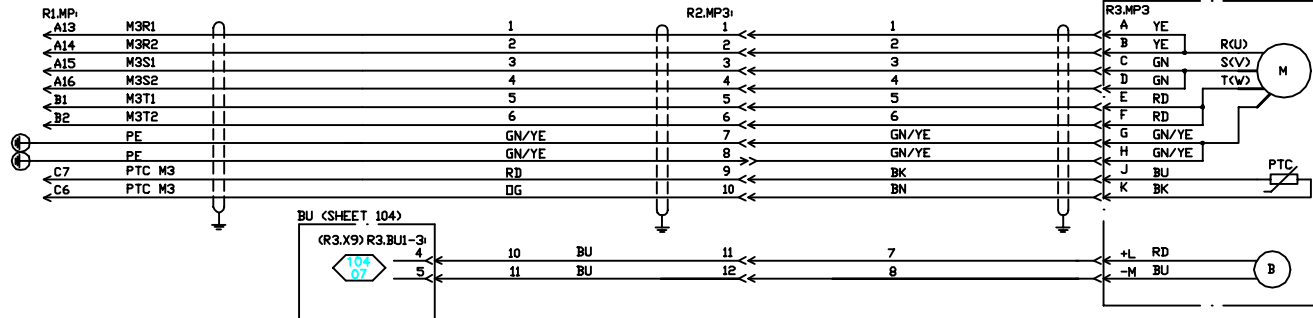

Preliminary Drawing
 NOT CHECKED!
 DATE: 05/23/95
 ABB Flexible Automation

CONVERTED TO NORTH AMERICAN FORMAT
 FROM EUROPEAN DOCUMENT NO. 3HAB 4247-1

We reserve all rights in this document and in the information contained therein. Reproduction, use or disclosure to third parties without express authority is strictly forbidden.
 ABB 10

DET. NO.	REV. NO.	CHANGE	DATE	BY

ABB ABB Inverter Supply Robotics Division

TITLE: ELECTRICAL DIAGRAM
 ABB PEDESTAL ROBOT - IRB 6400
 S4 M94A **AXIS 3**

DESIGNED BY	DRAWN BY	CHEK. BY	DATE	SCALE
			05/23/95	N/A

ABB DRAWING NO.	REV.	SHEET	CONT.
R0B 6400-50107-00	0	107 of 12	108

- 108 00
- 108 01
- 108 02
- 108 03
- 108 04
- 108 05
- 108 06
- 108 07
- 108 08
- 108 09
- 108 10
- 108 11
- 108 12
- 108 13
- 108 14
- 108 15
- 108 16
- 108 17
- 108 18
- 108 19
- 108 20

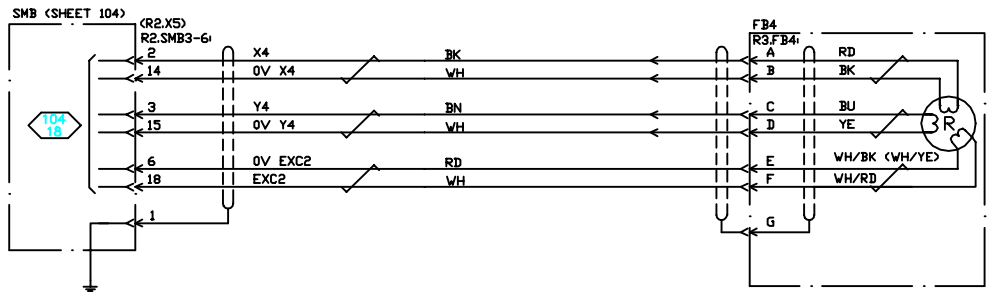
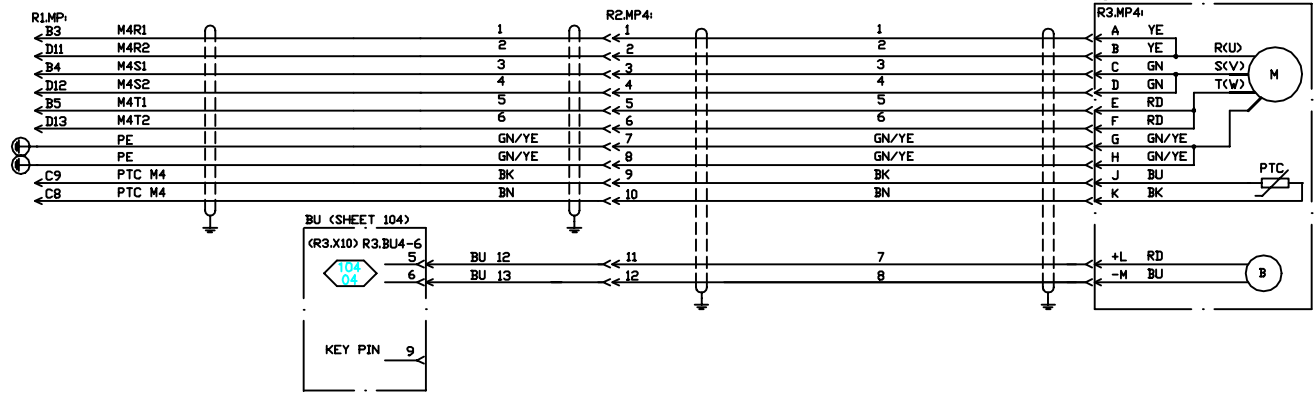

Preliminary Drawing
NOT CHECKED!
DATE: 05/23/95
ABB Flexible Automation

CONVERTED TO NORTH AMERICAN FORMAT
FROM EUROPEAN DOCUMENT NO. 3HAB 4247-1

We reserve all rights in this document and in the information contained therein. Reproduction, use or disclosure to third parties without express authority is strictly forbidden.
ABB 19

DET. NO.	REV. NO.	CHANGE	DATE	BY
TITLE ELECTRICAL DIAGRAM ABB PEDESTAL ROBOT - IRB 6400 S4 M94A				
AXIS 4				
DESIGNED BY	DRAWN BY	CHKD. BY	DATE	SCALE
	RSS		05/23/95	N/A
ABB DRAWING NO.	REV.	SHEET	CONT.	
RDB 6400-50108-00	0	108	of 12	109

- 109 00
- 109 01
- 109 02
- 109 03
- 109 04
- 109 05
- 109 06
- 109 07
- 109 08
- 109 09
- 109 10
- 109 11
- 109 12
- 109 13
- 109 14
- 109 15
- 109 16
- 109 17
- 109 18
- 109 19
- 109 20

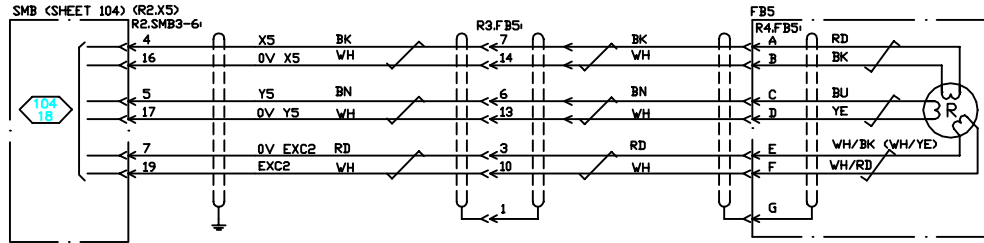
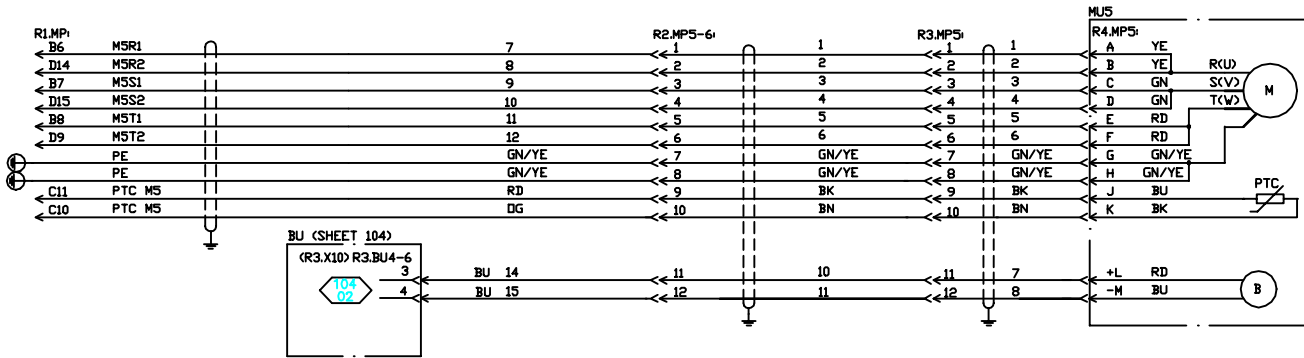

Preliminary Drawing
NOT CHECKED!
DATE: 05/23/95
ABB Flexible Automation

CONVERTED TO NORTH AMERICAN FORMAT
FROM EUROPEAN DOCUMENT NO. 3HAB 4247-1

We reserve all rights in this document and in the information contained therein. Reproduction, use or disclosure to third parties without express authority is strictly forbidden.

DET. NO.	REV. NO.	CHANGE	DATE	BY
ABB <small>ABB Inverter Systems Robotics Division</small>		TITLE ELECTRICAL DIAGRAM ABB PEDESTAL ROBOT - IRB 6400 S4 M94A		
DESIGNED BY RSS		CHKD. BY RSS		SCALE N/A
ABB DRAWING NO. RDB 6400-50109-00		DATE 05/23/95		SHEET 012
REV. 0		CONTD.		110

- 110 00
- 110 01
- 110 02
- 110 03
- 110 04
- 110 05
- 110 06
- 110 07
- 110 08
- 110 09
- 110 10
- 110 11
- 110 12
- 110 13
- 110 14
- 110 15
- 110 16
- 110 17
- 110 18
- 110 19
- 110 20

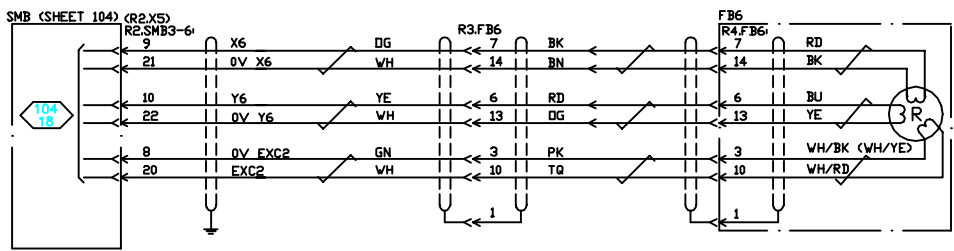
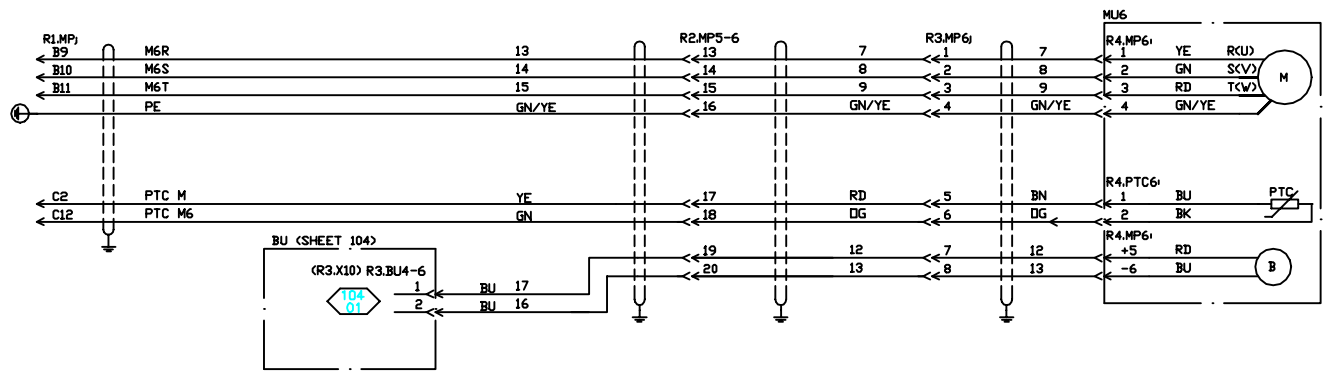

Preliminary Drawing
 NOT CHECKED!
 DATE: 05/23/95
 ABB Flexible Automation

CONVERTED TO NORTH AMERICAN FORMAT
 FROM EUROPEAN DOCUMENT NO. 3HAB 4247-1

We reserve all rights in this document and in the information contained therein. Reproductions, use or disclosure to third parties without express authority is strictly forbidden.
 ABB 19

DET. NO.	REV. NO.	CHANGE	DATE	BY
ABB <small>ABB POWER SYSTEMS Robotics Division</small>		TITLE ELECTRICAL DIAGRAM ABB PEDESTAL ROBOT - IRB 6400 S4 M94A AXIS 6		
DESIGNED BY	DRAWN BY	CHEK. BY	DATE	SCALE
			05/23/95	N/A
ABB DRAWING NO.	REV.	SHEET	CONT'D.	
RDB 6400-50110-00	0	110 of 12	111	

111 00
111 01
111 02
111 03
111 04
111 05
111 06
111 07
111 08
111 09
111 10
111 11
111 12
111 13
111 14
111 15
111 16
111 17
111 18
111 19
111 20

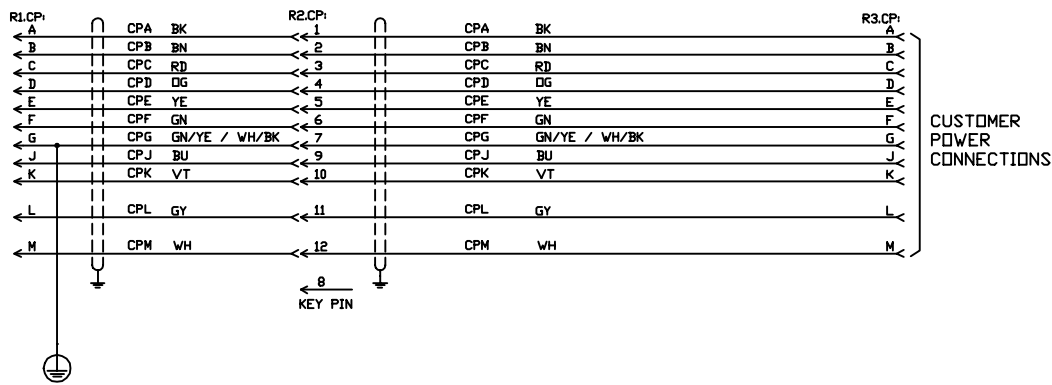

Preliminary Drawing
 NOT CHECKED!
 DATE: 05/23/95
 ABB Flexible Automation

CONVERTED TO NORTH AMERICAN FORMAT
 FROM EUROPEAN DOCUMENT NO. 3HAB 4247-1

We reserve all rights in this document and in the information contained therein. Reproduction, use or disclosure to third parties without express authority is strictly forbidden.
 ABB 19

DET. NO.	REV. NO.	CHANGE	DATE	BY
		TITLE ELECTRICAL DIAGRAM S4 M94A ABB PEDESTAL ROBOT - IRB 6400 CUSTOMER POWER CONNECTION		
DESIGNED BY	DRAWN BY	CHECKED BY	DATE	SCALE
RSS	RSS		05/23/95	N/A
ABB DRAWING NO.	REV.	SHEET	CONT'D.	
R0B 6400-50111-00	0	111 of 12	112	

112 00
112 01
112 02
112 03
112 04
112 05
112 06
112 07
112 08
112 09
112 10
112 11
112 12
112 13
112 14
112 15
112 16
112 17
112 18
112 19
112 20

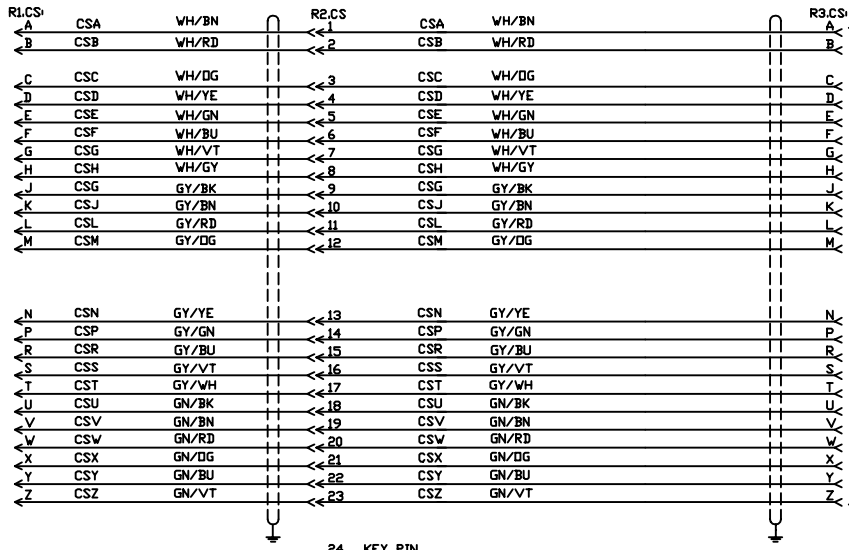

CUSTOMER SIGNAL CONNECTIONS

Preliminary Drawing
NOT CHECKED!
DATE: 05/23/95
ABB Flexible Automation

CONVERTED TO NORTH AMERICAN FORMAT
FROM EUROPEAN DOCUMENT NO. 3HAB 4247-1

We reserve all rights in this document and in the information contained therein. Reproduction, use or disclosure to third parties without express authority is strictly forbidden.
ABB 19

DET. NO.	REV. NO.	CHANGE	DATE	BY

ABB **ABB** **ABB**
 ABB Drive Systems Robotics Division
 TITLE: ELECTRICAL DIAGRAM
 S4 M94A
 ABB PEDESTAL ROBOT - IRB 6400
 CUSTOMER SIGNAL CONNECTIONS

DESIGNED BY	DRAWN BY	CHECK BY	DATE	SCALE
	RSS		05/23/95	N/A

ABB DRAWING NO.	REV.	SHEET	CONTD.
R0B 6400-50112-00	0	112 of 12	-