

# Aluminium electrolytic capacitors Power Eurodin Printed Wiring

050/052 PED-PW

### FEATURES

- Polarized aluminium electrolytic capacitors, non-solid
- Large types, cylindrical aluminium case, insulated with a blue sleeve
- Provided with keyed polarity
- 050 series also available in solder-lug (SL) versions
- Pressure relief on the top of the aluminium case
- Charge and discharge proof
- Very long useful life: 15000 hours at 85 °C
- Low ESR, high ripple current capability
- High resistance to shock and vibration.

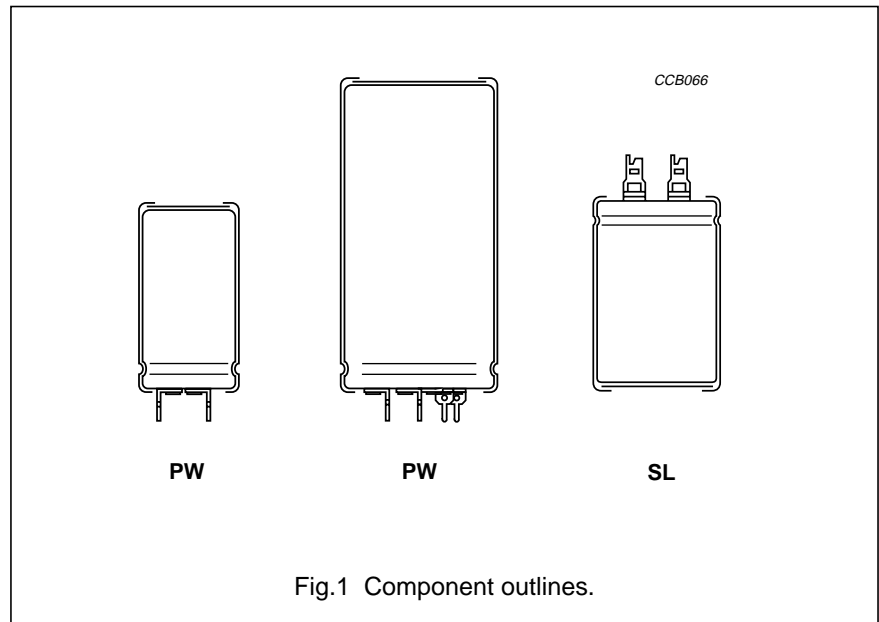

### APPLICATIONS

- Computer, telecommunication and industrial systems
- Smoothing and filtering
- Standard and switched mode power supplies
- Energy storage in pulse systems.

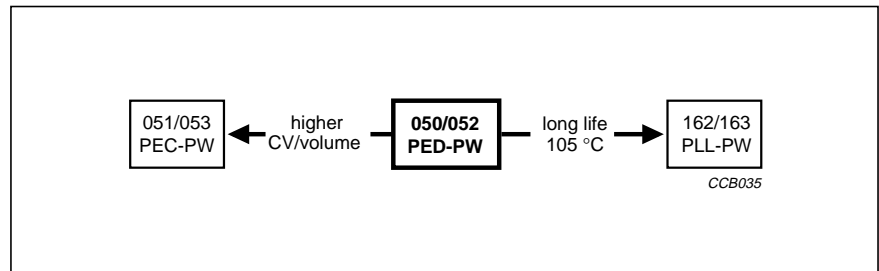

### QUICK REFERENCE DATA

DESCRIPTION	VALUE	
	050	052
Case size ( $\varnothing D_{nom} \times L_{nom}$ in mm)	25 × 30 to 40 × 100	
Rated capacitance range (E6 series), $C_R$	470 to 68000 $\mu F$	47 to 1000 $\mu F$
Tolerance on $C_R$	-10 to +30%	
Rated voltage range, $U_R$	10 to 100 V	250 to 400 V
Category temperature range	-40 to +85 °C	
Endurance test at 85 °C	5000 hours	
Useful life at 85 °C	15000 hours	
Useful life at 40 °C and $1.4 \times I_R$ applied	250000 hours	
Shelf life at 0 V, 85 °C	500 hours	
Based on sectional specification	IEC 384-4/CECC 30300	
Detail specification	DIN 45910-T129, former DIN 41238	
Climatic category IEC 68	40/085/56	

# Aluminium electrolytic capacitors

## Power Eurodin Printed Wiring

050/052 PED-PW

### Selection chart for $C_R$ , $U_R$ and relevant nominal case sizes ( $\varnothing D \times L$ in mm) for 050 series

Preferred types in **bold**.

$C_R$ ( $\mu F$ )	$U_R$ (V)					
	10	16	25	40	63	100
<b>470</b>	–	–	–	–	–	<b>25 × 30</b>
680	–	–	–	–	–	25 × 40
<b>1000</b>	–	–	–	–	<b>25 × 30</b>	<b>30 × 40</b>
1500	–	–	–	25 × 30	25 × 40	35 × 40
<b>2200</b>	–	–	<b>25 × 30</b>	<b>25 × 40</b>	<b>30 × 40</b>	<b>35 × 50</b>
	–	–	–	–	–	40 × 40
3300	–	25 × 30	25 × 40	30 × 40	35 × 40	40 × 50
<b>4700</b>	<b>25 × 30</b>	<b>25 × 40</b>	<b>30 × 40</b>	<b>35 × 40</b>	<b>35 × 50</b>	<b>40 × 70</b>
	–	–	–	–	40 × 40	–
6800	25 × 40	30 × 40	35 × 40	<b>35 × 50</b>	40 × 50	40 × 100
	–	–	–	40 × 40	–	–
<b>10000</b>	<b>30 × 40</b>	<b>35 × 40</b>	<b>35 × 50</b>	<b>40 × 50</b>	<b>40 × 70</b>	–
	–	–	40 × 40	–	–	–
15000	35 × 40	<b>35 × 50</b>	40 × 50	40 × 70	40 × 100	–
	–	40 × 40	–	–	–	–
<b>22000</b>	<b>35 × 50</b>	<b>40 × 50</b>	<b>40 × 70</b>	<b>40 × 100</b>	–	–
	40 × 40	–	–	–	–	–
33000	40 × 50	40 × 70	40 × 100	–	–	–
<b>47000</b>	<b>40 × 70</b>	<b>40 × 100</b>	–	–	–	–
68000	40 × 100	–	–	–	–	–

### Selection chart for $C_R$ , $U_R$ and relevant nominal case sizes ( $\varnothing D \times L$ in mm) for 052 series

Preferred types in **bold**.

$C_R$ ( $\mu F$ )	$U_R$ (V)		
	250	385	400
<b>47</b>	–	<b>25 × 30</b>	<b>25 × 30</b>
68	–	25 × 40	25 × 40
<b>100</b>	<b>25 × 30</b>	<b>30 × 40</b>	<b>30 × 40</b>
150	25 × 40	35 × 40	35 × 40
<b>220</b>	<b>30 × 40</b>	<b>35 × 50</b>	<b>35 × 50</b>
	–	40 × 40	40 × 40
330	35 × 40	40 × 50	40 × 50
<b>470</b>	<b>35 × 50</b>	<b>40 × 70</b>	<b>40 × 70</b>
	40 × 40	–	–
680	40 × 50	–	40 × 100
<b>1000</b>	<b>40 × 70</b>	–	–

Aluminium electrolytic capacitors  
Power Eurodin Printed Wiring

050/052 PED-PW

MECHANICAL DATA AND PACKAGING QUANTITIES

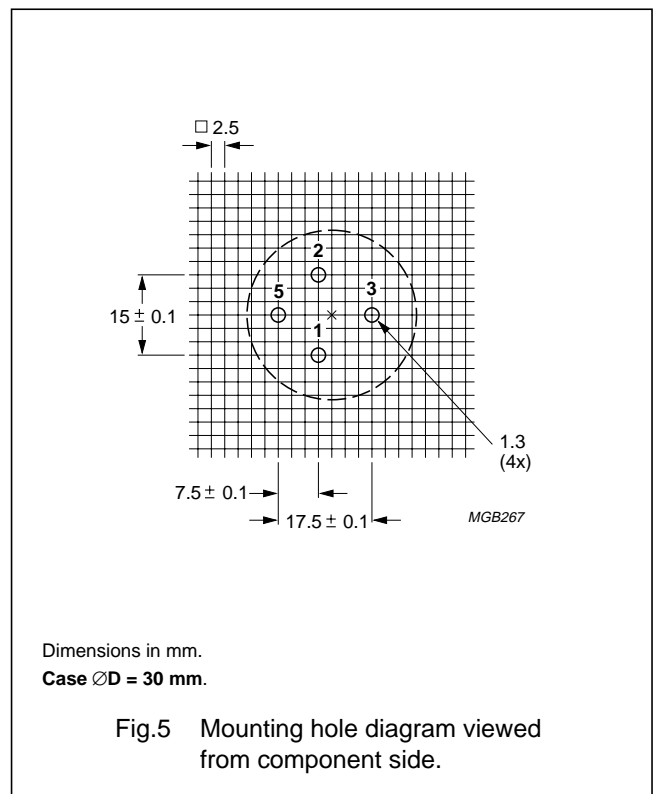
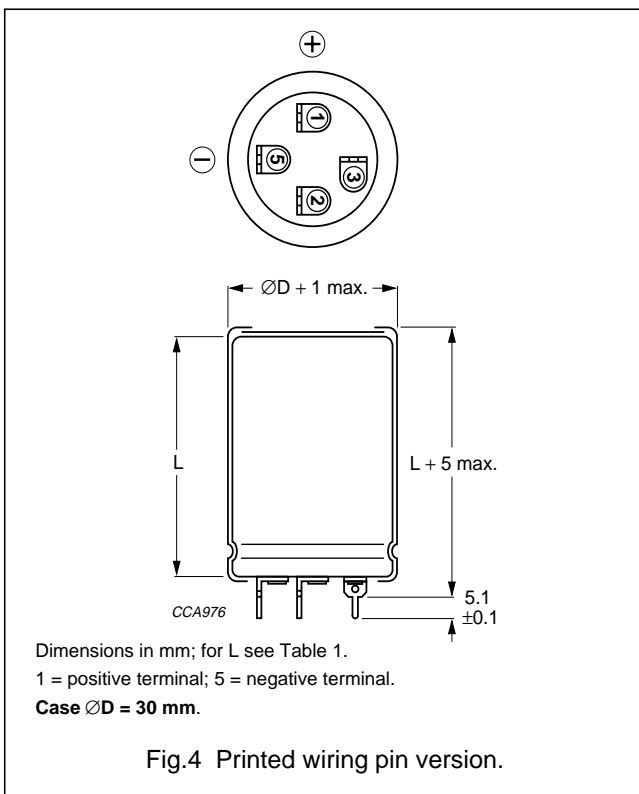
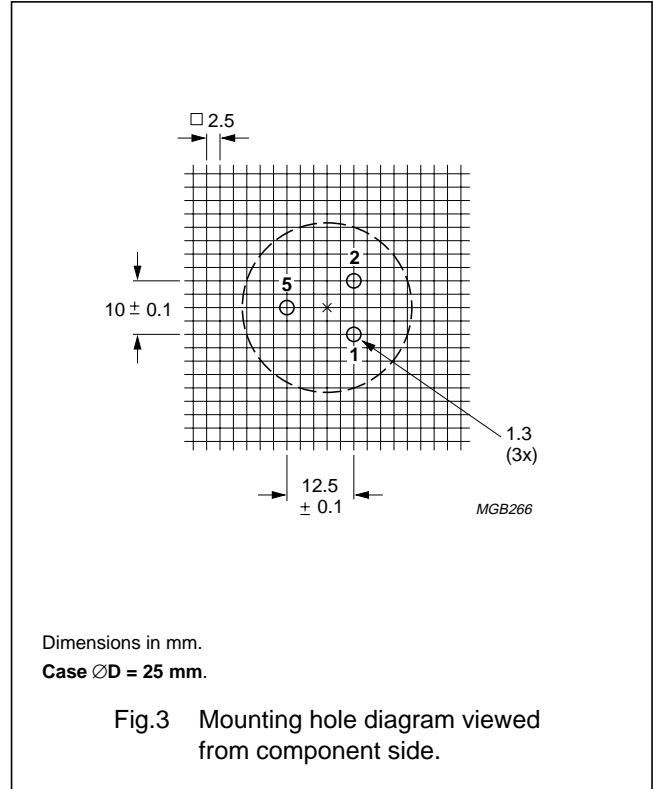
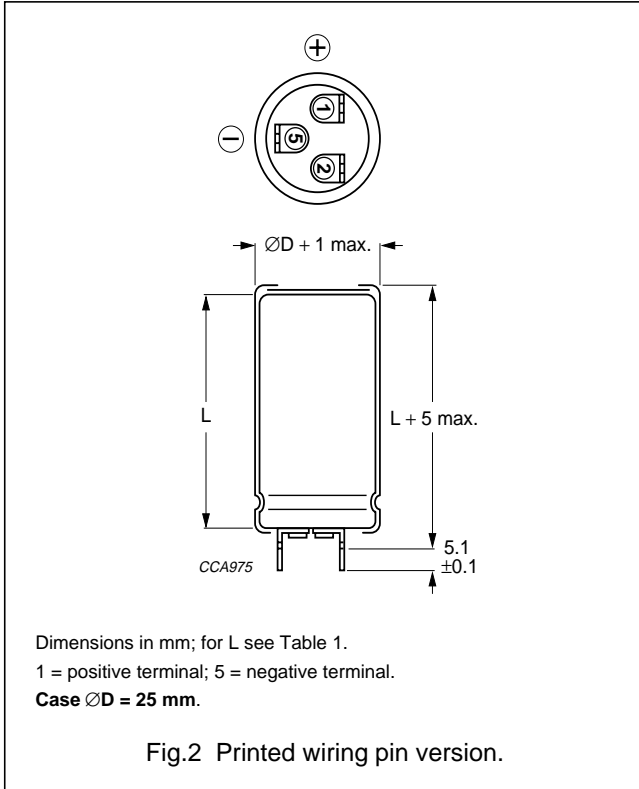

Aluminium electrolytic capacitors  
Power Eurodin Printed Wiring

050/052 PED-PW

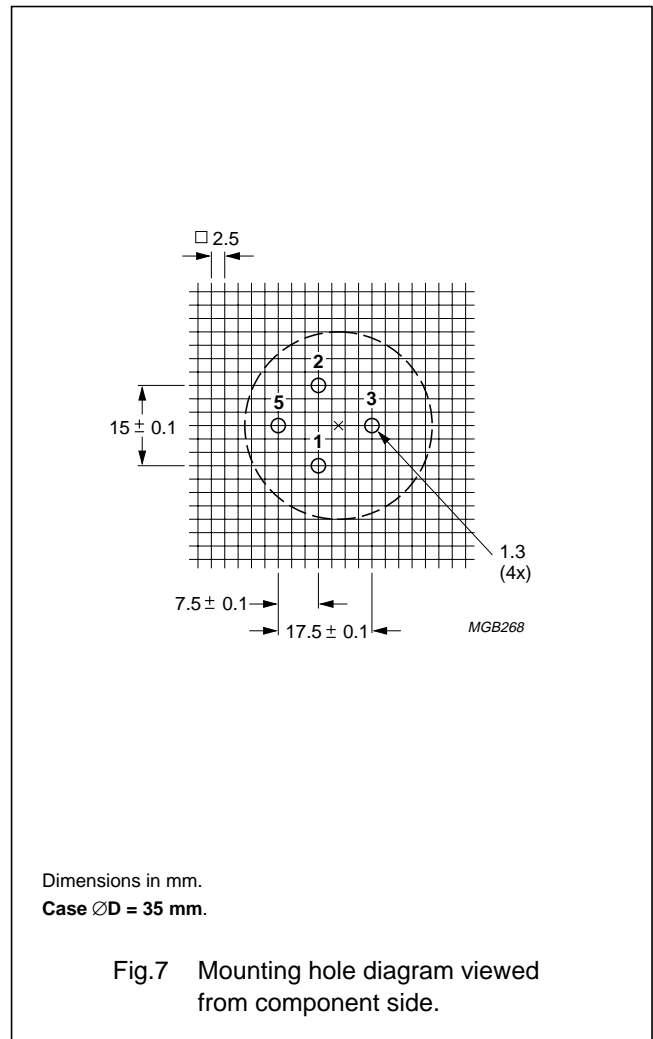
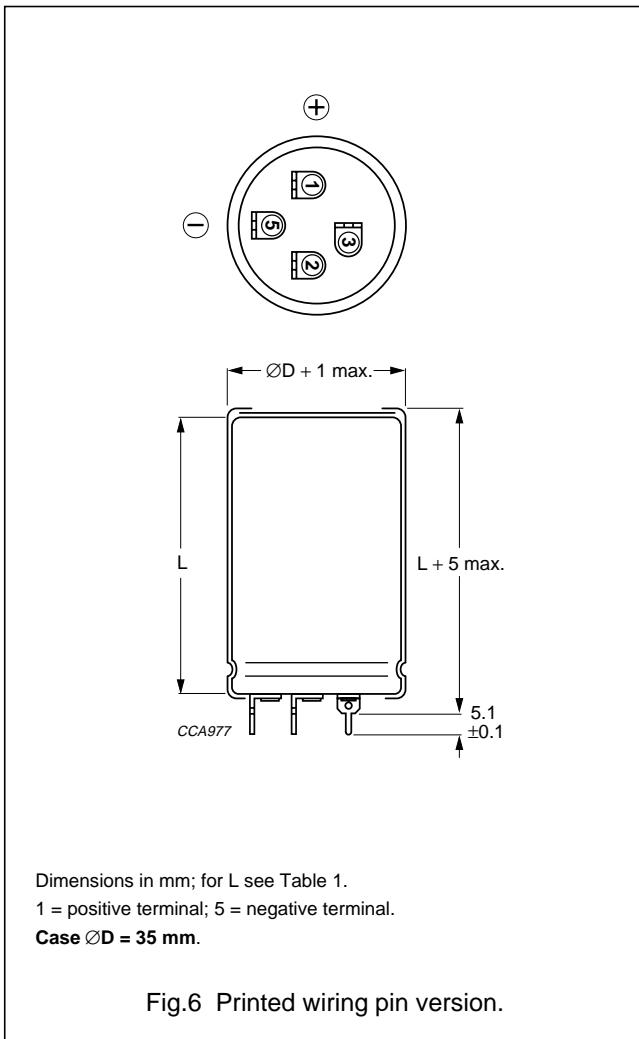

**Table 1 PW versions;** physical dimensions, mass and packaging information; see Figs 2, 4, 6 and 8

NOMINAL CASE SIZE $\varnothing D \times L$ (mm)	$\varnothing D_{max}$ (mm)	$L_{max}$ (mm)	MASS (g)	PACKAGING QUANTITIES (units per box)	CARDBOARD BOX DIMENSIONS $l \times w \times h$ (mm)
25 × 30	26	35	≈24	100	290 × 280 × 45
25 × 40	26	45	≈28	100	290 × 280 × 55
30 × 40	31	45	≈38	100	340 × 330 × 55
35 × 40	36	45	≈51	50	390 × 198 × 55
35 × 50	36	55	≈66	50	390 × 198 × 65
40 × 40	41	45	≈78	50	440 × 223 × 55
40 × 50	41	55	≈82	50	440 × 223 × 65
40 × 70	41	75	≈110	50	440 × 223 × 85
40 × 100	41	105	≈176	50	440 × 223 × 115

L

Aluminium electrolytic capacitors  
Power Eurodin Printed Wiring

050/052 PED-PW

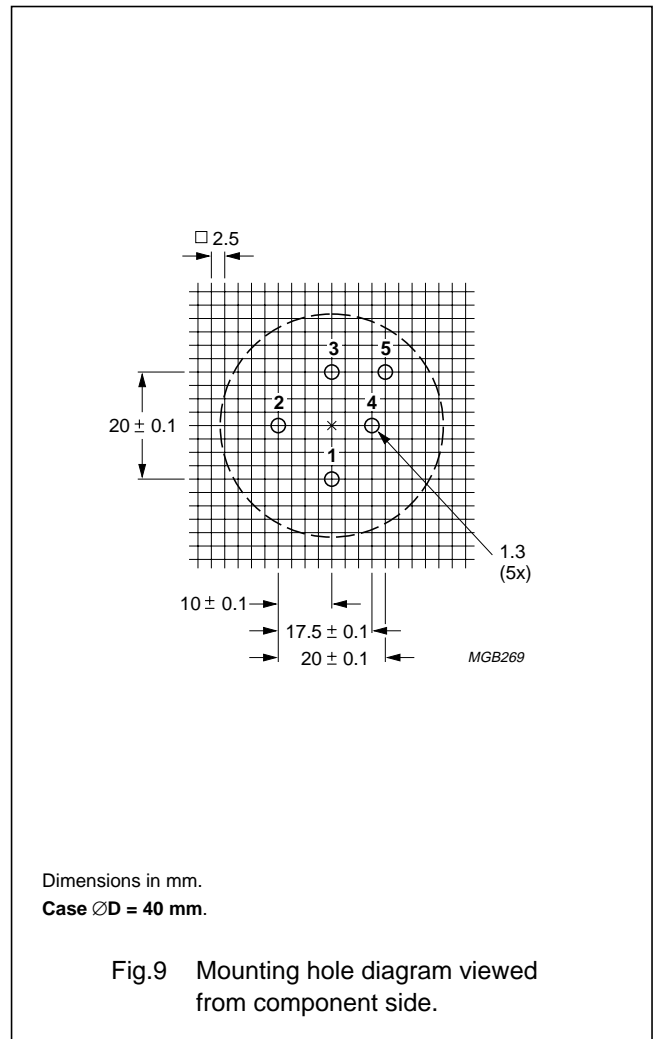
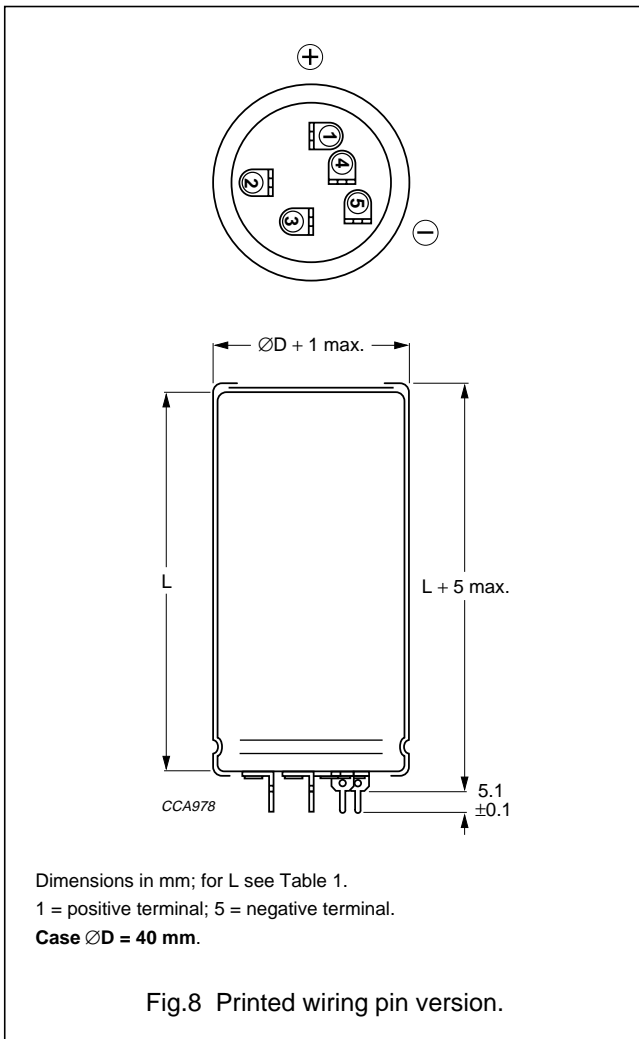

**Mounting**

When a number of capacitors are connected in a bank, they must not be closer together than 15 mm, when no derating of ripple current and/or temperature is applied.

Pin numbers 2, 3 and 4 (if present) must be free from the electrical circuit.

Aluminium electrolytic capacitors  
Power Eurodin Printed Wiring

050/052 PED-PW

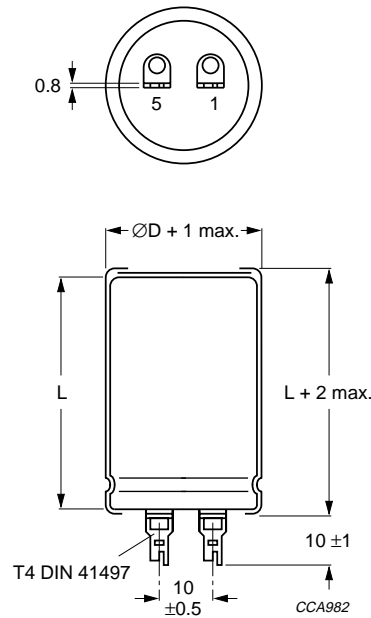

Dimensions in mm; for L see Table 2.  
1 = positive terminal; 5 = negative terminal.  
See this handbook, Section "Mounting Accessories".

Fig.10 Solder-lug version (SL); only available in 050 series.

**Table 2 SL versions (050 series only);** physical dimensions, mass and packaging information; see Fig.10

NOMINAL CASE SIZE ØD × L (mm)	ØD <sub>max</sub> (mm)	L <sub>max</sub> (mm)	MASS (g)	PACKAGING QUANTITIES (units per box)	CARDBOARD BOX DIMENSIONS l × w × h (mm)
25 × 30	26	32	≈24	100	290 × 280 × 65
25 × 40	26	42	≈28	100	290 × 280 × 75
30 × 40	31	42	≈38	100	340 × 330 × 75
35 × 40	36	42	≈51	50	390 × 198 × 75
35 × 50	36	52	≈66	50	390 × 198 × 85
40 × 50	41	52	≈82	50	440 × 223 × 85
40 × 70	41	72	≈110	50	440 × 223 × 105
40 × 100	41	102	≈176	50	440 × 223 × 135

L

# Aluminium electrolytic capacitors

## Power Eurodin Printed Wiring

050/052 PED-PW

**ELECTRICAL DATA AND ORDERING INFORMATION**

Unless otherwise specified, all electrical values in Tables 3 and 4 apply at  
 $T_{amb} = 20\text{ °C}$ ,  $P = 86\text{ to }106\text{ kPa}$ ,  $RH = 45\text{ to }75\%$ .

SYMBOL	DESCRIPTION
$C_R$	rated capacitance at 100 Hz
$I_R$	rated RMS ripple current at 100 Hz, 85 °C or at 20 kHz, 70 °C
$I_{L1}$	max. leakage current after 1 minute at $U_R$
$I_{L5}$	max. leakage current after 5 minutes at $U_R$
ESR	max. equivalent series resistance at 100 Hz
Z	max. impedance at 10 kHz

**Ordering example**

Electrolytic capacitor 050 series

10000  $\mu\text{F}/25\text{ V}$ ;  $-10/+30\%$ Nominal case size:  $\varnothing 35 \times 50\text{ mm}$ ;  
PW version

Catalogue number: 2222 050 56103.

**Table 3** Electrical data and ordering information for **050** series; preferred types in **bold**

$U_R$ (V)	$C_R$ 100 Hz ( $\mu\text{F}$ )	NOMINAL CASE SIZE $\varnothing D \times L$ (mm)	$I_R$ 100 Hz 85 °C (A)	$I_R$ 20 kHz 70 °C (A)	$I_{L1}$ 1 min (mA)	$I_{L5}$ 5 min (mA)	ESR 100 Hz (m $\Omega$ )	Z 10 kHz (m $\Omega$ )	CATALOGUE NUMBER (note 1) 2222 ... ..
10	<b>4700</b>	<b>25 × 30</b>	2.4	4.6	0.28	0.10	74	50	<b>050 54472</b>
	6800	25 × 40	3.2	6.1	0.41	0.14	51	37	050 54682
	<b>10000</b>	<b>30 × 40</b>	3.8	7.2	0.60	0.20	39	29	<b>050 54103</b>
	15000	35 × 40	4.1	7.8	0.90	0.30	35	26	050 54153
	<b>22000</b>	<b>35 × 50</b>	5.0	9.5	1.32	0.44	27	21	<b>050 54223</b>
	22000	40 × 40	4.2	8.0	1.32	0.44	36	27	050 44223
	33000	40 × 50	5.0	9.5	1.98	0.66	29	22	050 54333
	<b>47000</b>	<b>40 × 70</b>	6.8	12.9	2.82	0.94	20	17	<b>050 54473</b>
68000	40 × 100	9.2	17.5	4.08	1.36	15	14	050 54683	
16	3300	25 × 30	2.4	4.6	0.32	0.11	75	50	050 55332
	<b>4700</b>	<b>25 × 40</b>	3.1	5.9	0.45	0.15	52	37	<b>050 55472</b>
	6800	30 × 40	3.7	7.0	0.65	0.22	40	30	050 55682
	<b>10000</b>	<b>35 × 40</b>	4.1	7.8	0.96	0.32	36	27	<b>050 55103</b>
	15000	35 × 50	5.0	9.5	1.44	0.48	28	21	050 55153
	15000	40 × 40	4.2	8.0	1.44	0.48	36	27	050 45153
	<b>22000</b>	<b>40 × 50</b>	5.0	9.5	2.12	0.71	29	22	<b>050 55223</b>
	33000	40 × 70	6.7	12.7	3.17	1.06	20	17	050 55333
<b>47000</b>	<b>40 × 100</b>	9.1	17.3	4.51	1.51	15	14	<b>050 55473</b>	
25	<b>2200</b>	<b>25 × 30</b>	2.3	4.4	0.33	0.11	78	52	<b>050 56222</b>
	3300	25 × 40	3.1	5.9	0.49	0.17	53	38	050 56332
	<b>4700</b>	<b>30 × 40</b>	3.7	7.0	0.70	0.24	42	31	<b>050 56472</b>
	6800	35 × 40	4.1	7.8	1.02	0.34	37	28	050 56682
	<b>10000</b>	<b>35 × 50</b>	5.0	9.5	1.50	0.50	28	21	<b>050 56103</b>
	10000	40 × 40	4.2	8.0	1.50	0.50	36	27	050 46103
	15000	40 × 50	5.0	9.5	2.25	0.75	29	22	050 56153
	<b>22000</b>	<b>40 × 70</b>	6.8	12.9	3.30	1.10	20	17	<b>050 56223</b>
33000	40 × 100	9.2	17.5	4.95	1.65	15	14	050 56333	

# Aluminium electrolytic capacitors

## Power Eurodin Printed Wiring

050/052 PED-PW

$U_R$ (V)	$C_R$ 100 Hz ( $\mu\text{F}$ )	NOMINAL CASE SIZE $\varnothing D \times L$ (mm)	$I_R$ 100 Hz 85 °C (A)	$I_R$ 20 kHz 70 °C (A)	$I_{L1}$ 1 min (mA)	$I_{L5}$ 5 min (mA)	ESR 100 Hz (m $\Omega$ )	Z 10 kHz (m $\Omega$ )	CATALOGUE NUMBER (note 1) 2222 ... .....
40	1500	25 × 30	2.0	3.8	0.36	0.12	112	68	050 57152
	<b>2200</b>	<b>25 × 40</b>	2.7	5.1	0.53	0.18	76	51	<b>050 57222</b>
	3300	30 × 40	3.3	6.3	0.79	0.27	57	41	050 57332
	<b>4700</b>	<b>35 × 40</b>	3.8	7.2	1.13	0.38	48	35	<b>050 57472</b>
	6800	35 × 50	4.7	8.9	1.64	0.55	36	27	050 57682
	6800	40 × 40	4.1	7.8	1.64	0.55	45	33	050 47682
	<b>10000</b>	<b>40 × 50</b>	4.9	9.3	2.40	0.80	35	27	<b>050 57103</b>
	15000	40 × 70	6.6	12.5	3.60	1.20	25	20	050 57153
	<b>22000</b>	<b>40 × 100</b>	9.0	17.1	5.28	1.76	18	16	<b>050 57223</b>
63	<b>1000</b>	<b>25 × 30</b>	1.8	3.4	0.38	0.13	122	74	<b>050 58102</b>
	1500	25 × 40	2.5	4.7	0.57	0.19	83	54	050 58152
	<b>2200</b>	<b>30 × 40</b>	3.1	5.9	0.83	0.28	57	41	<b>050 58222</b>
	3300	35 × 40	3.6	6.8	1.25	0.42	48	35	050 58332
	<b>4700</b>	<b>35 × 50</b>	4.4	8.3	1.78	0.60	36	27	<b>050 58472</b>
	4700	40 × 40	3.8	7.2	1.78	0.60	45	33	050 48472
	6800	40 × 50	4.7	8.9	2.57	0.86	35	27	050 58682
	<b>10000</b>	<b>40 × 70</b>	6.2	11.8	3.78	1.26	25	20	<b>050 58103</b>
	15000	40 × 100	8.5	16.1	5.67	1.89	18	16	050 58153
100	<b>470</b>	<b>25 × 30</b>	1.4	2.7	0.28	0.10	247	172	<b>050 59471</b>
	680	25 × 40	1.9	3.6	0.41	0.14	170	116	050 59681
	<b>1000</b>	<b>30 × 40</b>	2.5	4.7	0.60	0.20	123	88	<b>050 59102</b>
	1500	35 × 40	3.1	5.8	0.90	0.30	94	71	050 59152
	<b>2200</b>	<b>35 × 50</b>	3.9	7.4	1.32	0.44	69	55	<b>050 59222</b>
	2200	40 × 40	3.6	6.8	1.32	0.44	81	65	050 49222
	3300	40 × 50	4.6	8.7	1.98	0.66	59	48	050 59332
	<b>4700</b>	<b>40 × 70</b>	6.2	11.7	2.82	0.94	42	36	<b>050 59472</b>
	6800	40 × 100	8.2	15.5	4.08	1.36	32	28	050 59682

**Note**

- Catalogue number applies to the PW versions; for SL versions (not preferred) available in 050 series only (case size  $\varnothing 40 \times 40$  mm not available) replace the 8th digit by '1': SL versions: 2222 050 1....

L



# Aluminium electrolytic capacitors

## Power Eurodin Printed Wiring

050/052 PED-PW

**Table 4** Electrical data and ordering information for **052** series; preferred types in **bold**

$U_R$ (V)	$C_R$ 100 Hz ( $\mu\text{F}$ )	NOMINAL CASE SIZE $\varnothing D \times L$ (mm)	$I_R$ 100 Hz 85 °C (A)	$I_R$ 20 kHz 70 °C (A)	$I_{L1}$ 1 min (mA)	$I_{L5}$ 5 min (mA)	ESR 100 Hz (m $\Omega$ )	Z 10 kHz (m $\Omega$ )	CATALOGUE NUMBER 2222 ... ..
250	<b>100</b>	<b>25 × 30</b>	0.6	1.15	0.15	0.05	1800	1300	<b>052 53101</b>
	150	25 × 40	0.8	1.5	0.23	0.08	1100	850	052 53151
	<b>220</b>	<b>30 × 40</b>	1.0	1.9	0.33	0.11	750	550	<b>052 53221</b>
	330	35 × 40	1.4	2.65	0.49	0.17	500	400	052 53331
	<b>470</b>	<b>35 × 50</b>	1.8	3.4	0.70	0.24	360	290	<b>052 53471</b>
	470	40 × 40	1.8	3.4	0.70	0.24	420	350	052 43471
	680	40 × 50	2.3	4.4	1.02	0.34	250	190	052 53681
	<b>1000</b>	<b>40 × 70</b>	3.0	5.7	1.50	0.50	170	140	<b>052 53102</b>
385	<b>47</b>	<b>25 × 30</b>	0.5	0.94	0.11	0.04	2370	1550	<b>052 58479</b>
	68	25 × 40	0.67	1.27	0.16	0.06	1640	1100	052 58689
	<b>100</b>	<b>30 × 40</b>	0.84	1.59	0.23	0.08	1275	950	<b>052 58101</b>
	150	35 × 40	1.13	2.14	0.34	0.11	850	635	052 58151
	<b>220</b>	<b>35 × 50</b>	1.48	2.8	0.50	0.17	580	430	<b>052 58221</b>
	220	40 × 40	1.48	2.8	0.50	0.17	580	430	052 48221
	330	40 × 50	1.97	3.73	0.75	0.25	385	300	052 58331
	<b>470</b>	<b>40 × 70</b>	2.7	5.11	1.06	0.36	270	215	<b>052 58471</b>
400	<b>47</b>	<b>25 × 30</b>	0.47	0.89	0.11	0.04	2700	2125	<b>052 56479</b>
	68	25 × 40	0.63	1.29	0.16	0.06	1875	1470	052 56689
	<b>100</b>	<b>30 × 40</b>	0.84	1.59	0.24	0.08	1275	1000	<b>052 56101</b>
	150	35 × 40	1.13	2.14	0.36	0.12	850	665	052 56151
	<b>220</b>	<b>35 × 50</b>	1.41	2.67	0.52	0.17	650	450	<b>052 56221</b>
	220	40 × 40	1.41	2.67	0.52	0.17	650	450	052 46221
	330	40 × 50	1.86	3.52	0.79	0.26	435	315	052 56331
	<b>470</b>	<b>40 × 70</b>	2.54	4.81	1.12	0.37	305	225	<b>052 56471</b>
680	40 × 100	3.56	6.75	1.63	0.54	210	155	052 56681	

Aluminium electrolytic capacitors  
Power Eurodin Printed Wiring

050/052 PED-PW

Additional electrical data

PARAMETER	CONDITIONS	VALUE
<b>Voltage</b>		
Surge voltage for short periods	≤250 V versions	$U_s = 1.15 \times U_R$
	≥385 V versions	$U_s = 1.1 \times U_R$
Reverse voltage		$U_{rev} \leq 1 V$
<b>Current</b>		
Leakage current	after 1 minute at $U_R$	$I_{L1} \leq 0.006C_R \times U_R + 4 \mu A$
	after 5 minutes at $U_R$	$I_{L5} \leq 0.002C_R \times U_R + 4 \mu A$
<b>Inductance</b>		
Equivalent series inductance (ESL)	case $\varnothing D = 25$ mm	max. 25 nH
	case $\varnothing D = 30$ and 35 mm	max. 30 nH
	case $\varnothing D = 40$ mm	max. 35 nH

Capacitance (C)

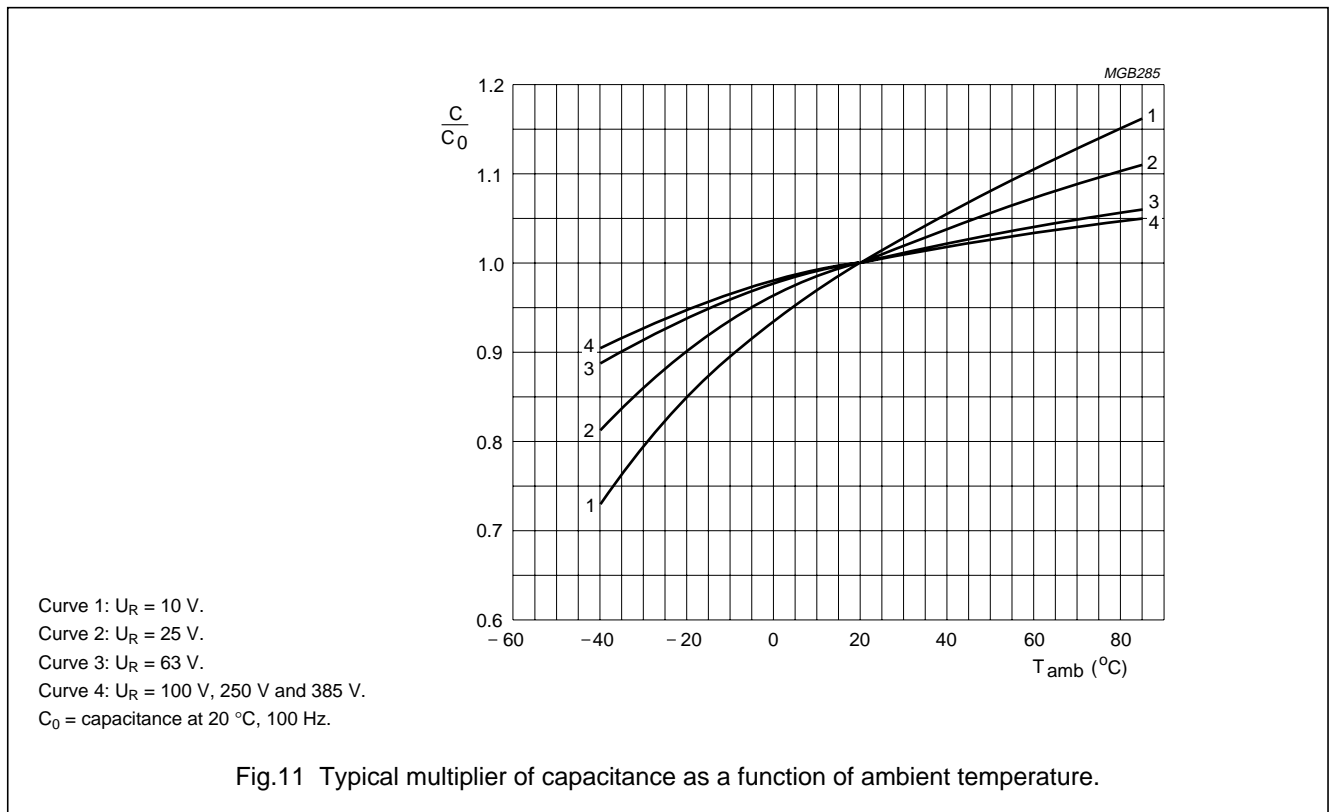

Aluminium electrolytic capacitors  
Power Eurodin Printed Wiring

050/052 PED-PW

Equivalent series resistance (ESR)

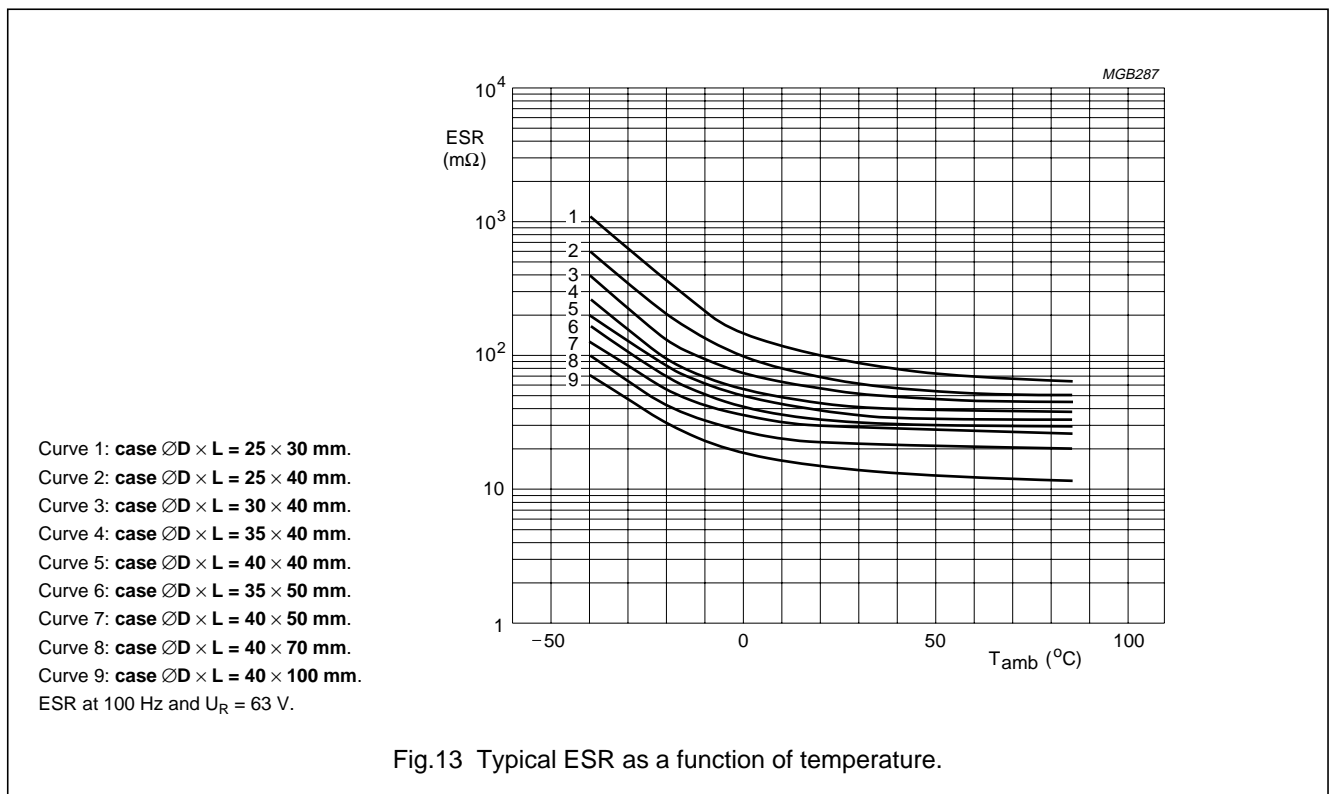
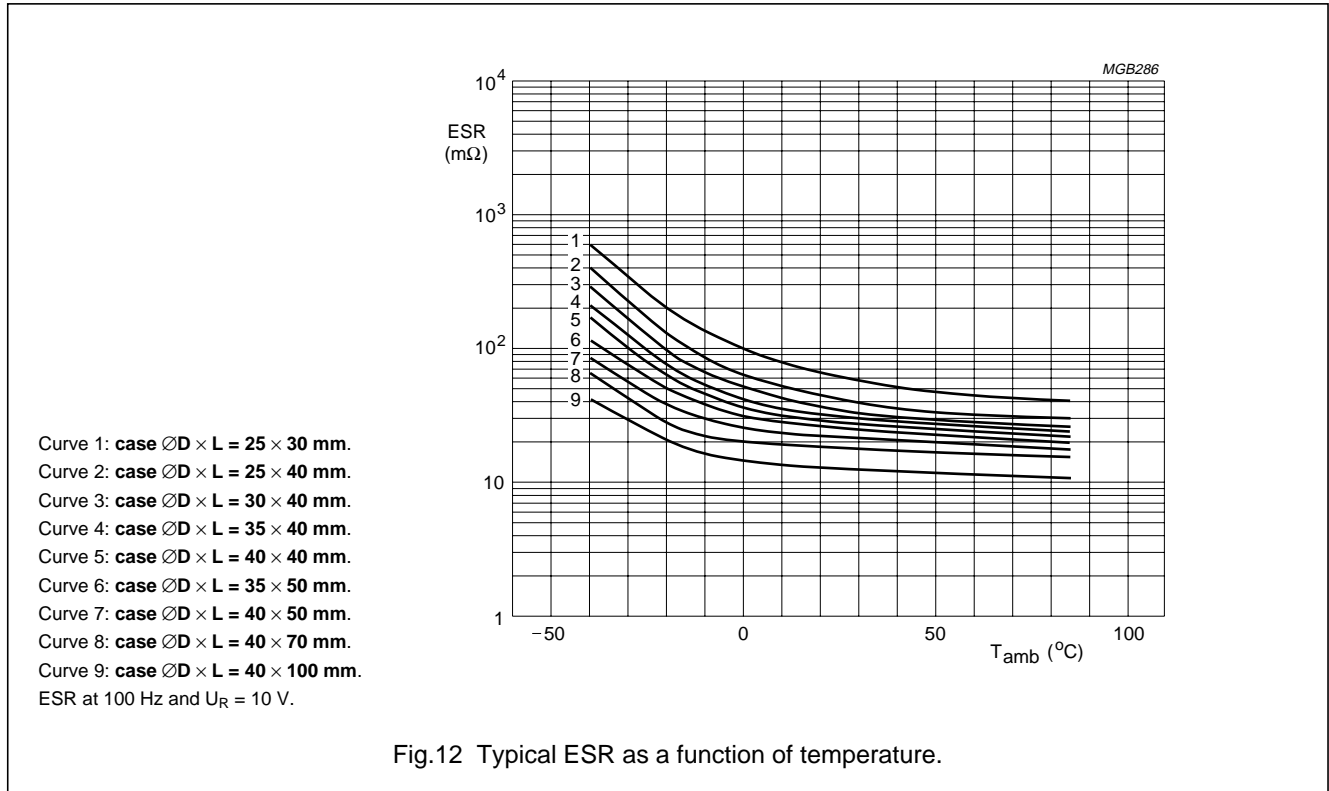

Aluminium electrolytic capacitors  
Power Eurodin Printed Wiring

050/052 PED-PW

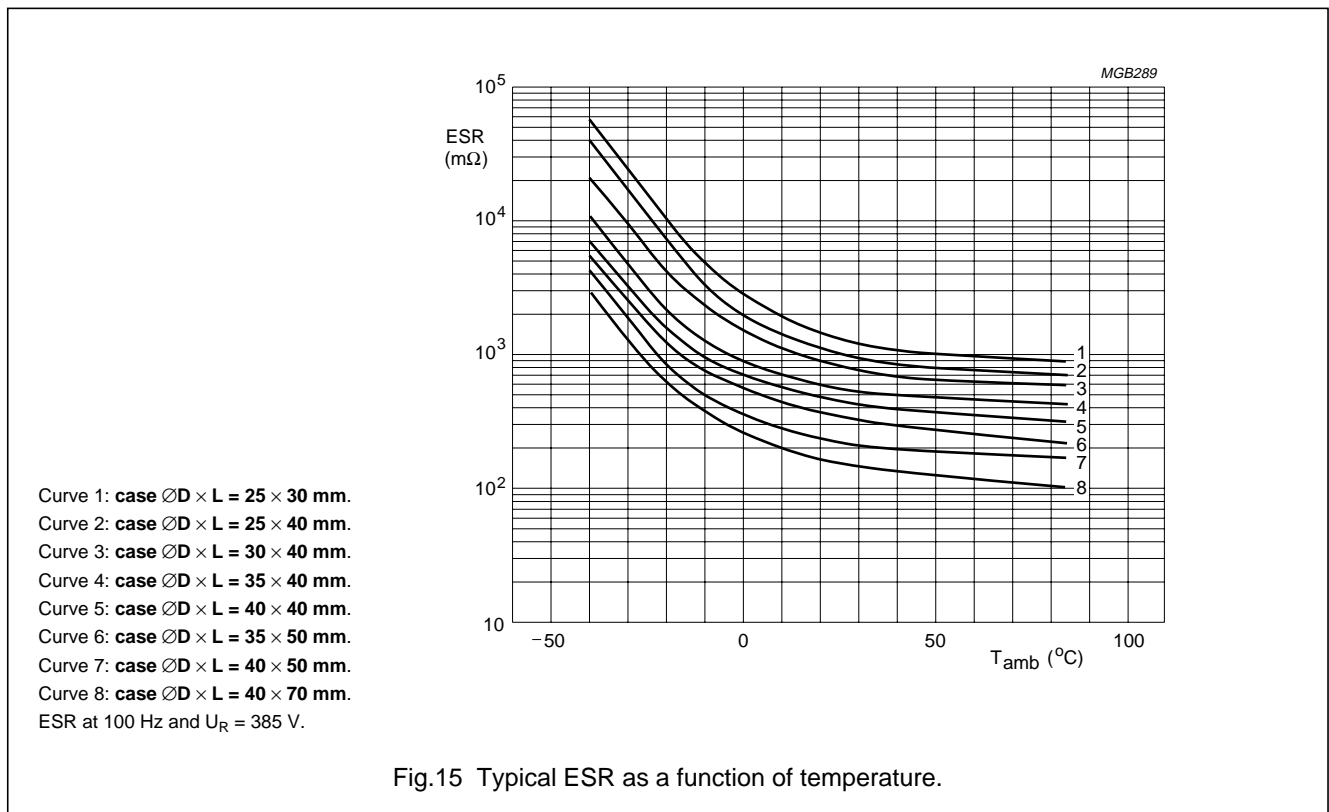
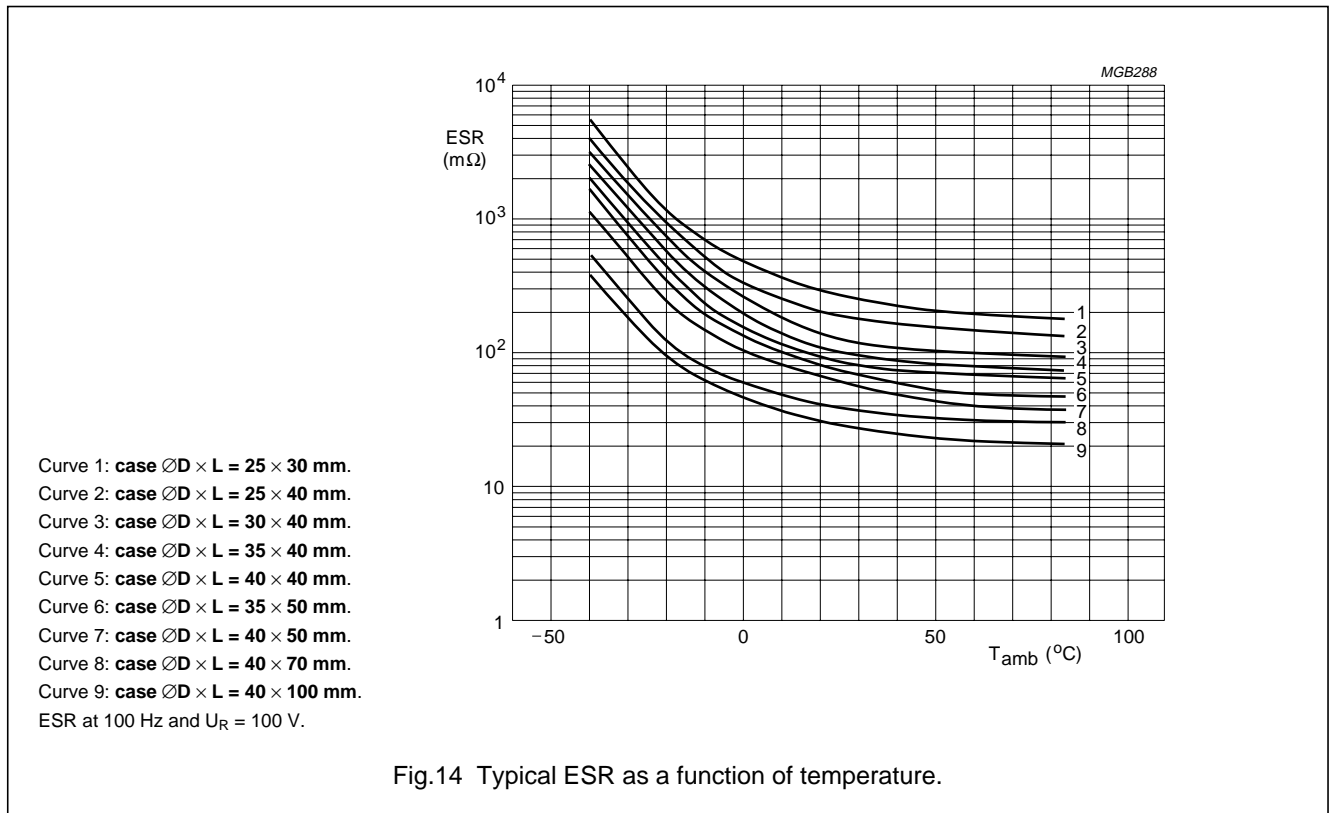

Aluminium electrolytic capacitors  
Power Eurodin Printed Wiring

050/052 PED-PW

Impedance (Z)

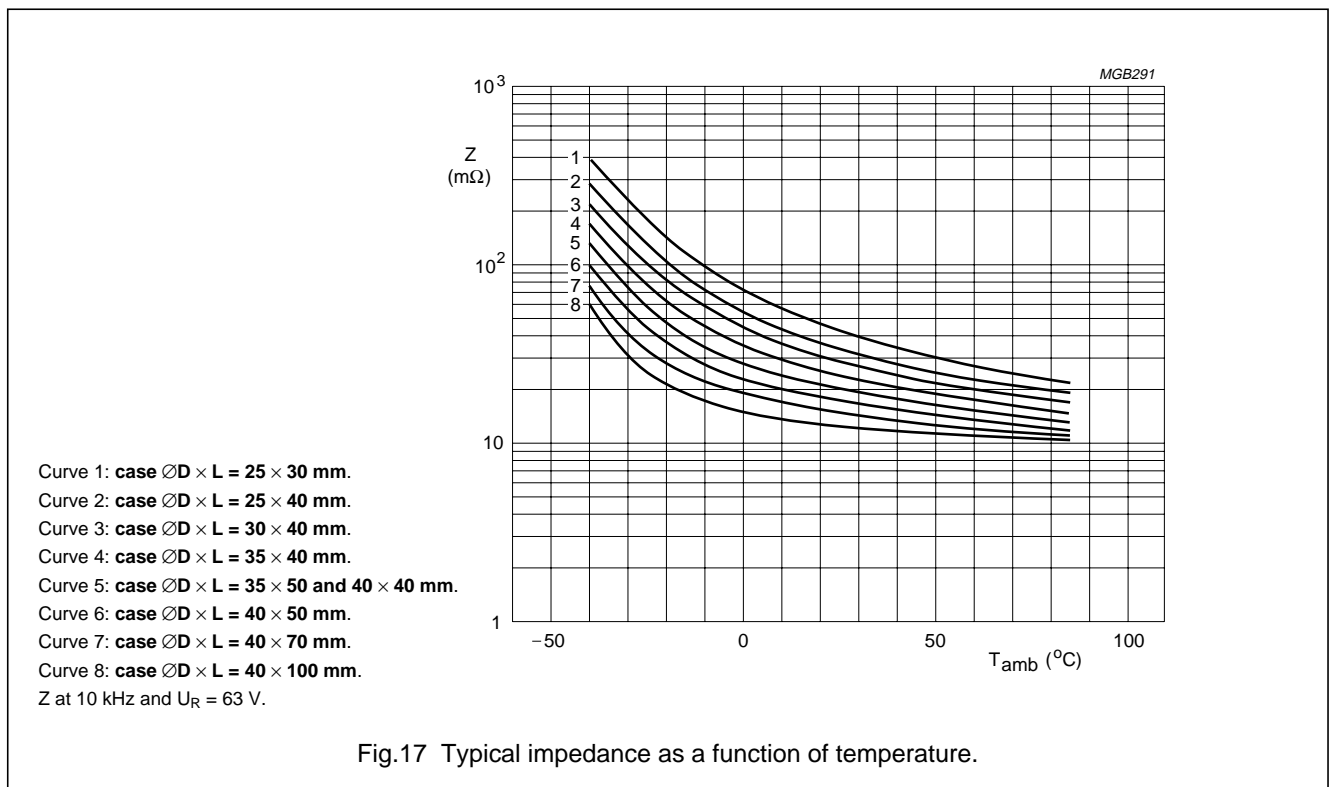
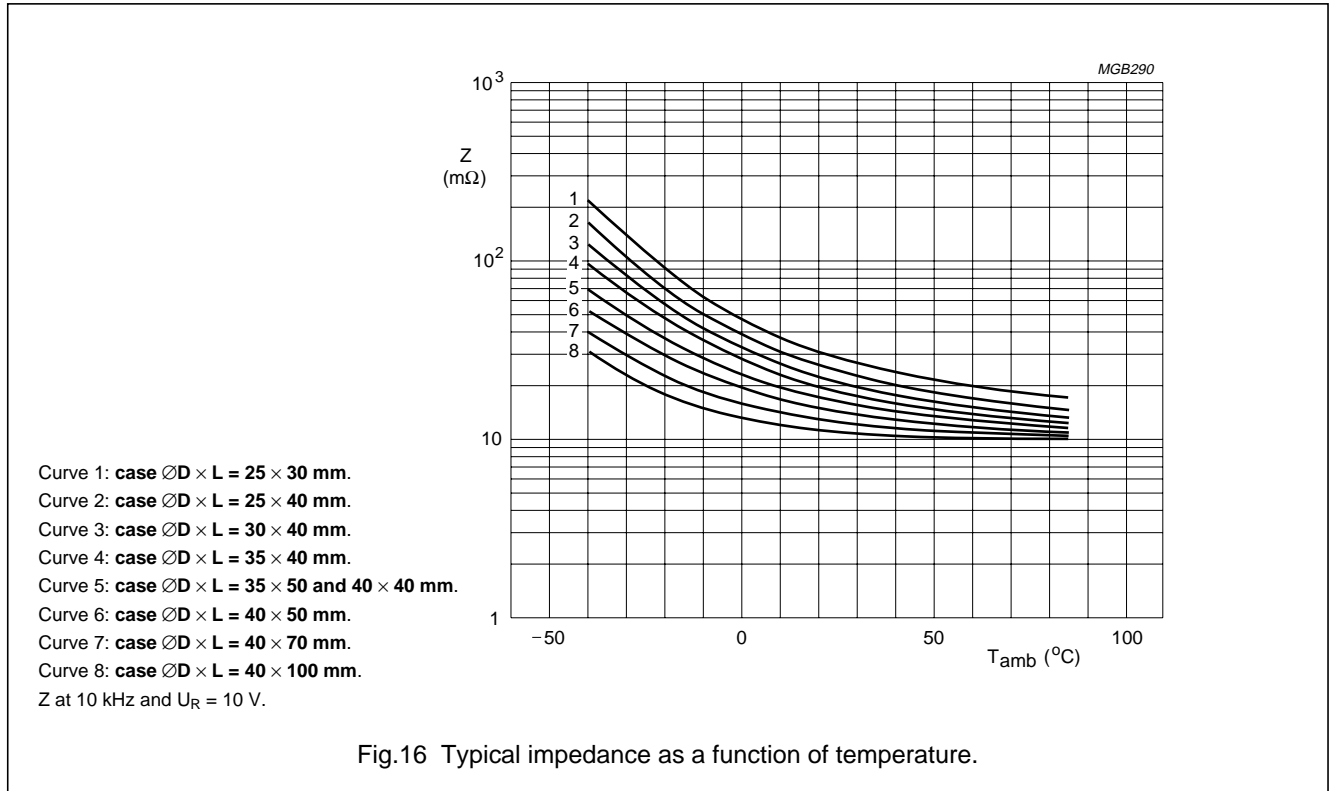

Aluminium electrolytic capacitors  
Power Eurodin Printed Wiring

050/052 PED-PW

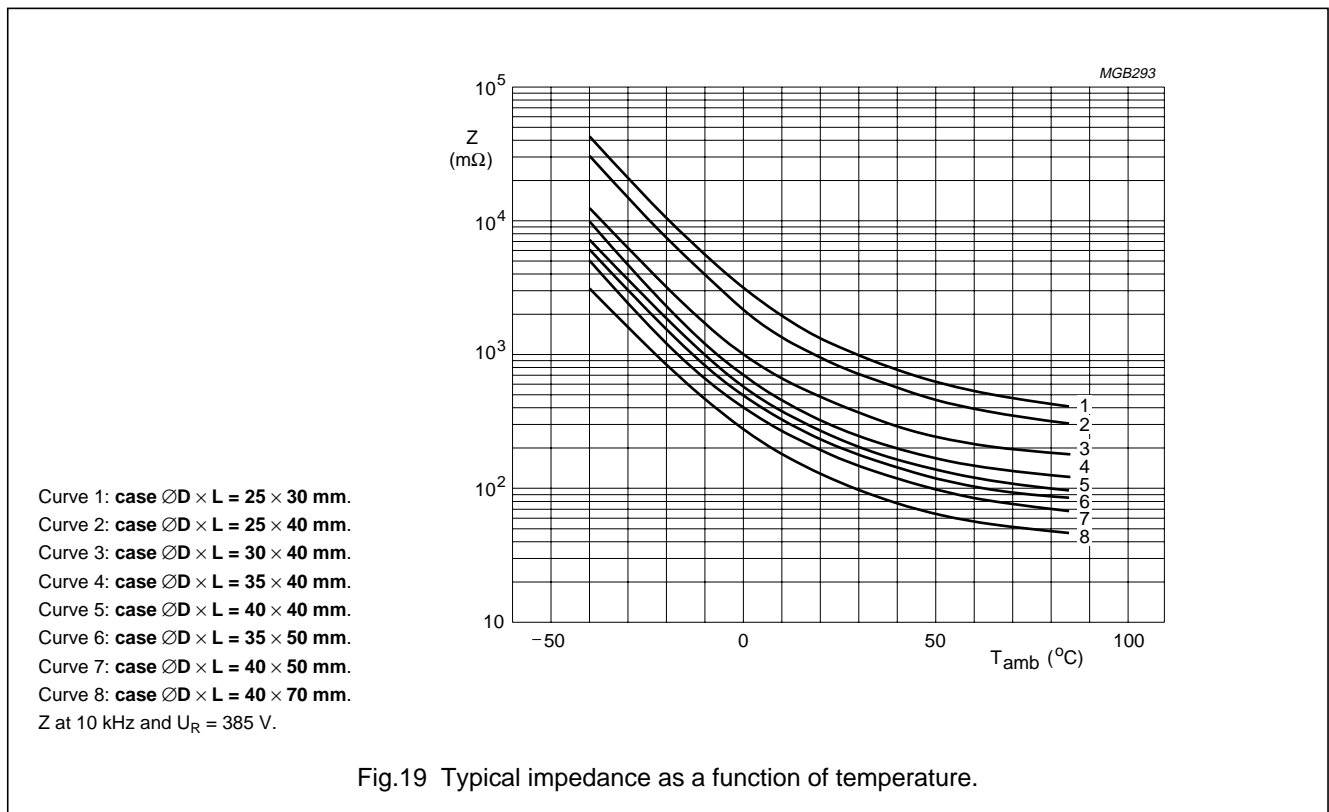
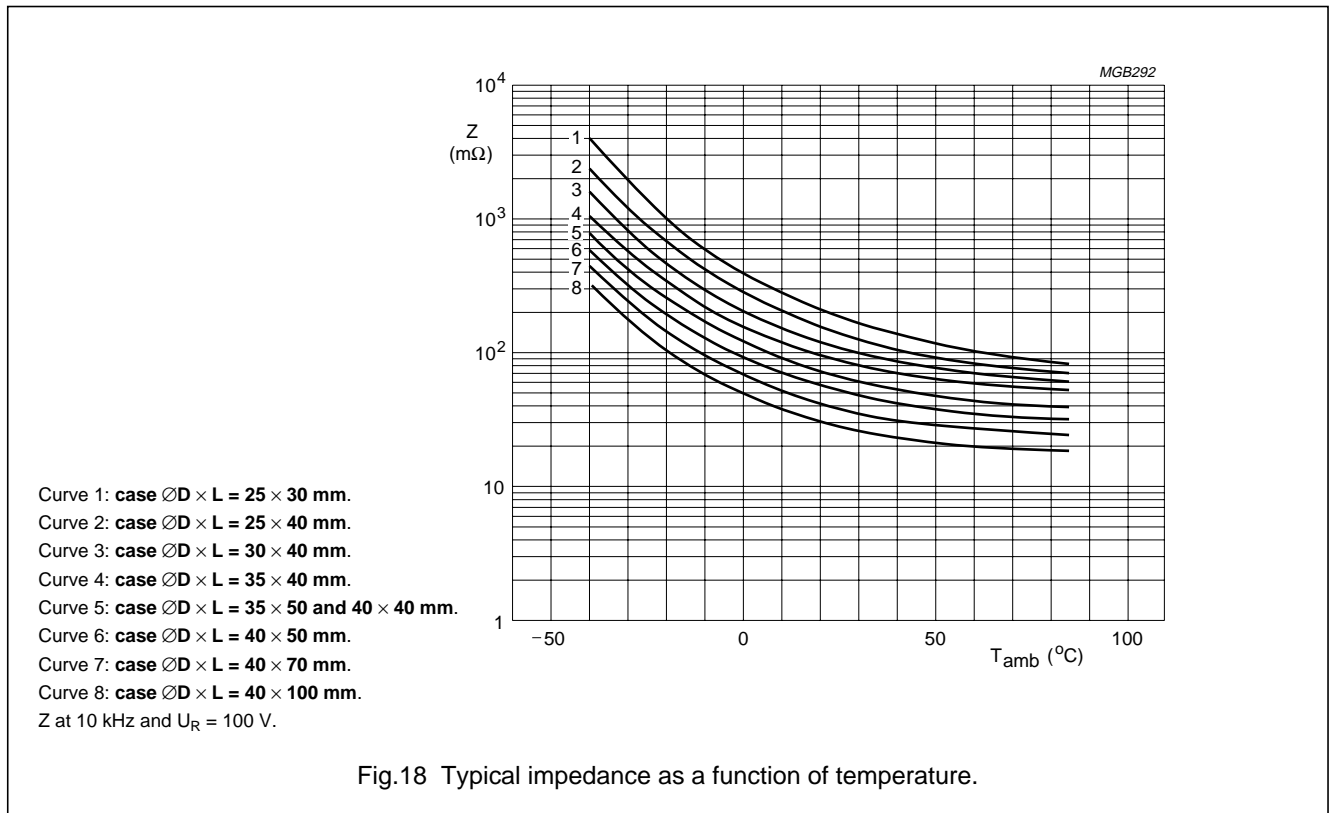

L

Aluminium electrolytic capacitors  
Power Eurodin Printed Wiring

050/052 PED-PW

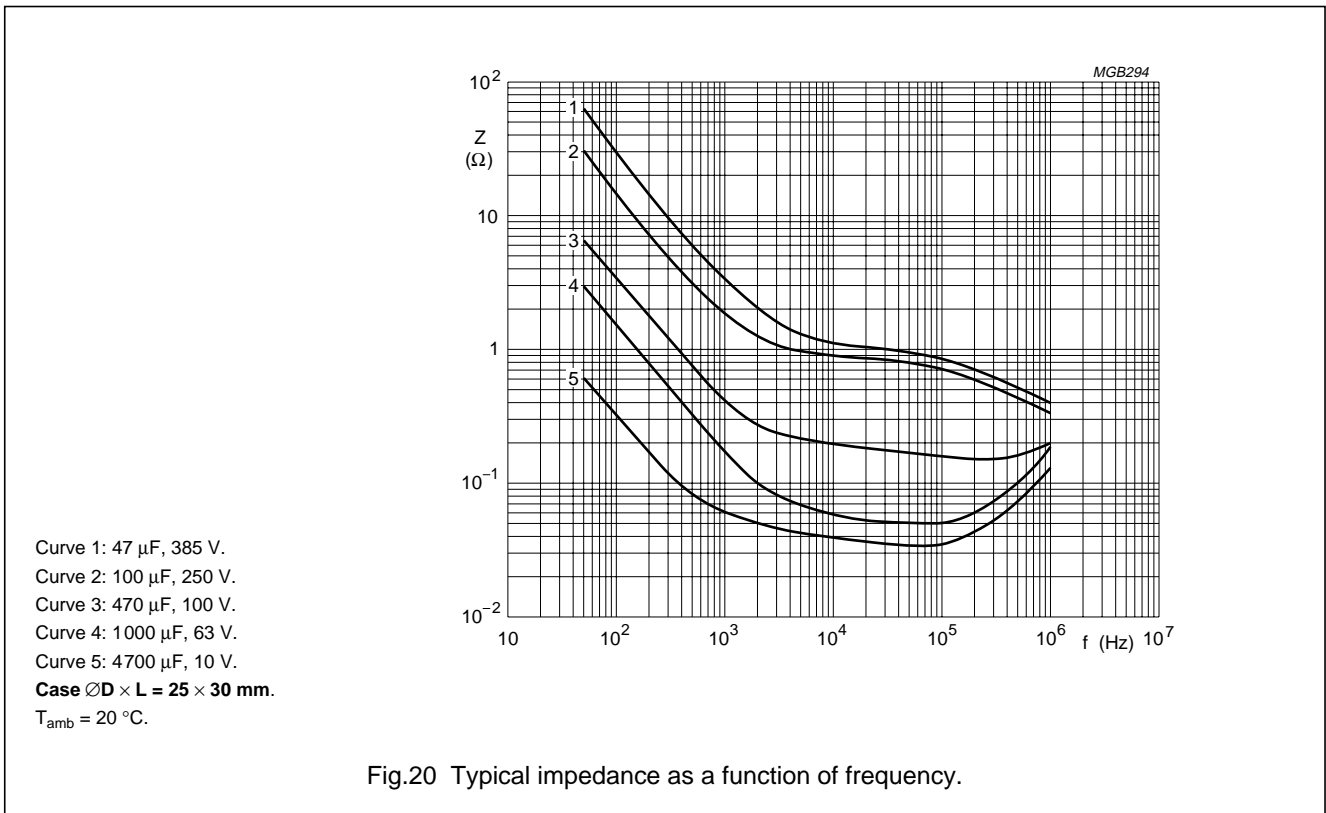

Fig.20 Typical impedance as a function of frequency.

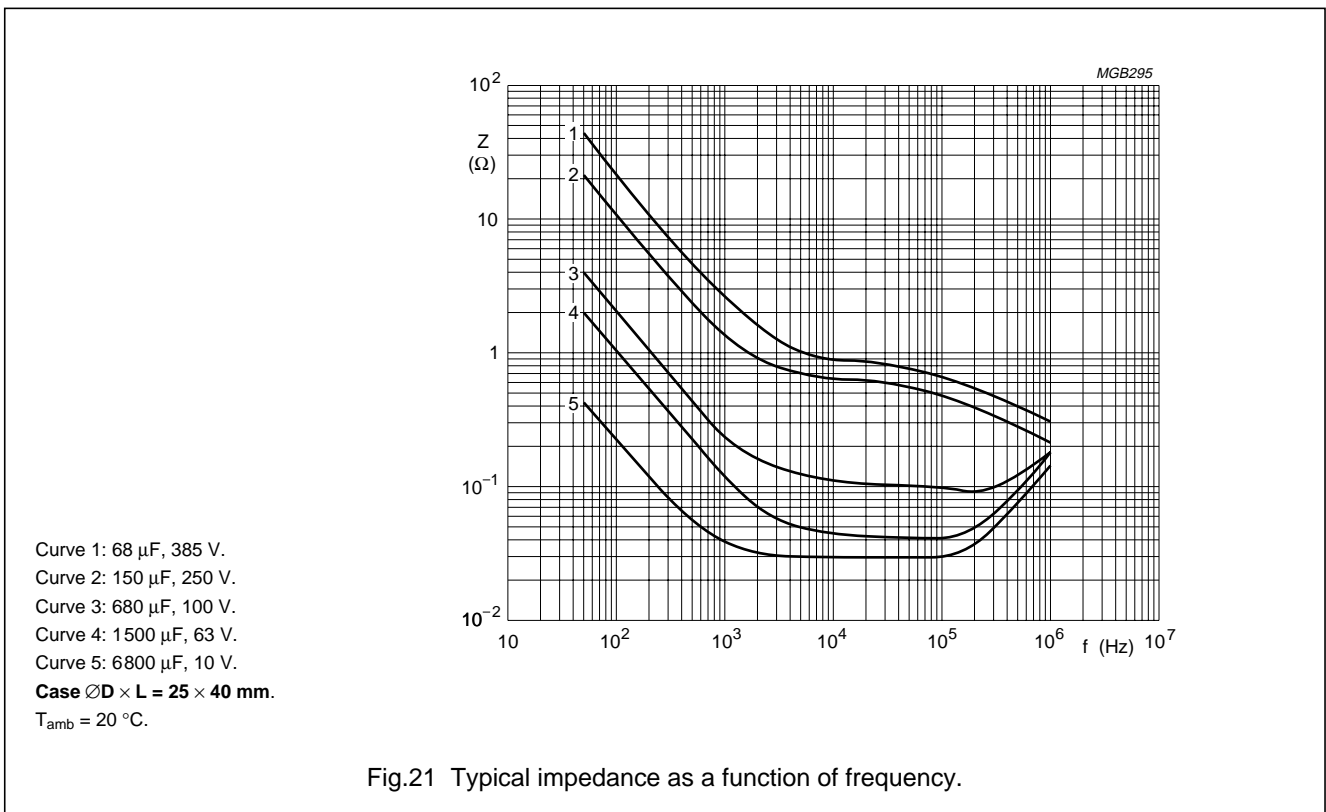
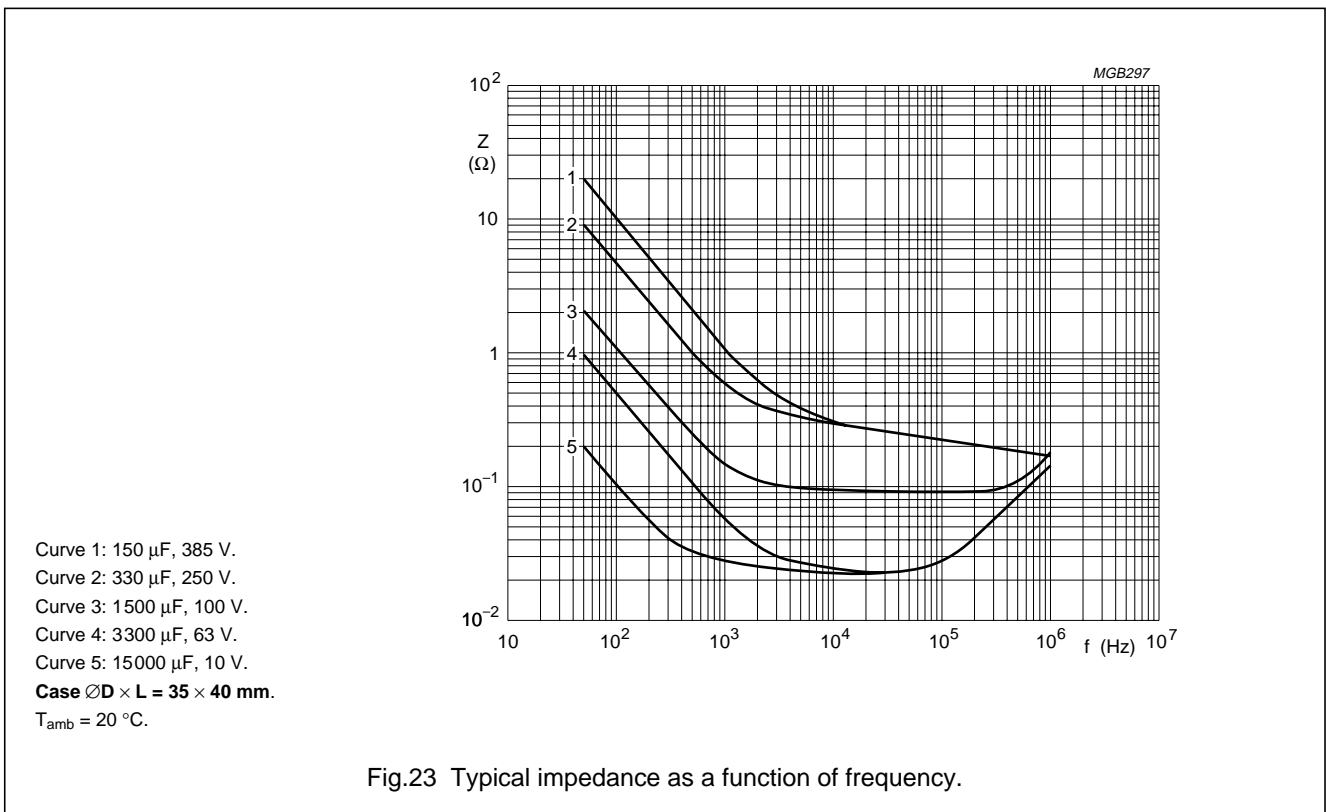
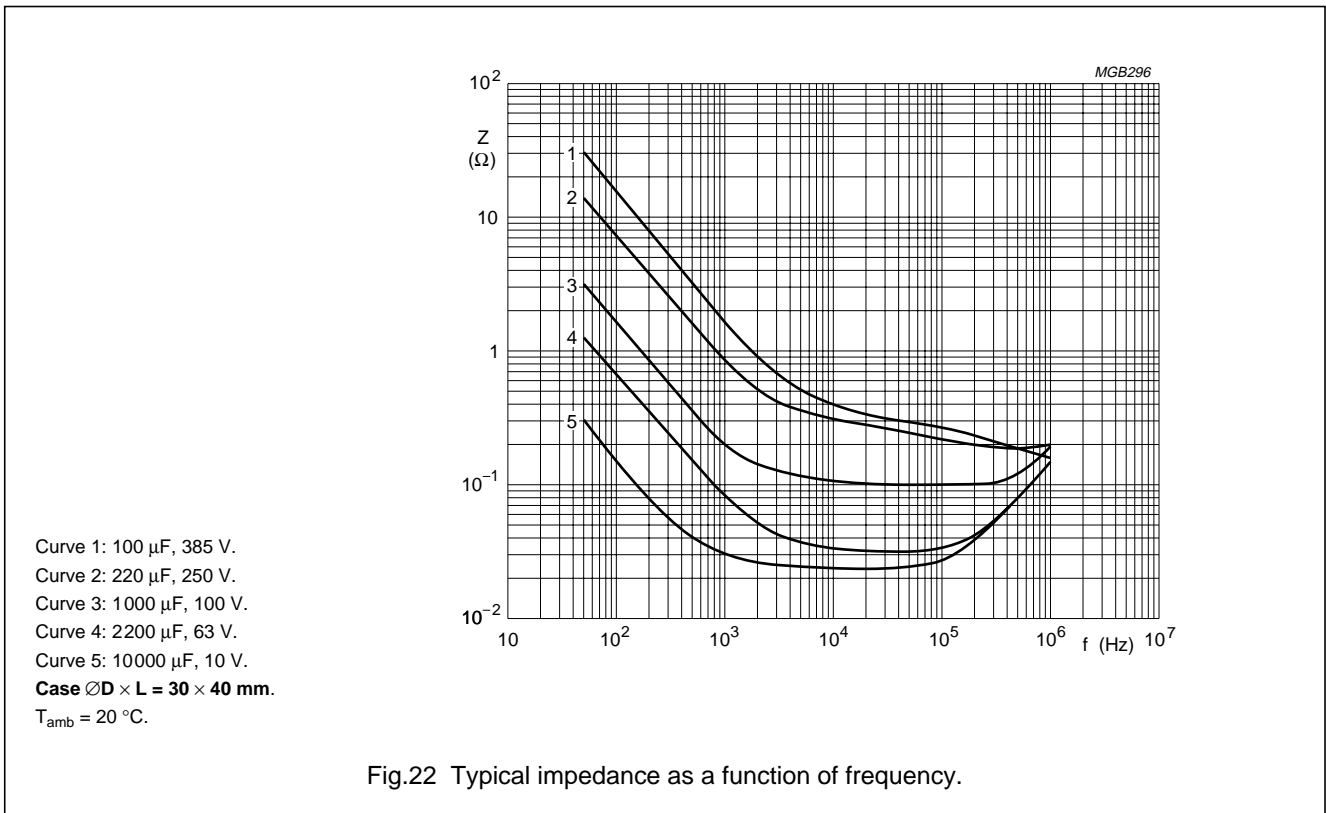

Fig.21 Typical impedance as a function of frequency.

Aluminium electrolytic capacitors  
Power Eurodin Printed Wiring

050/052 PED-PW



L



Aluminium electrolytic capacitors  
Power Eurodin Printed Wiring

050/052 PED-PW

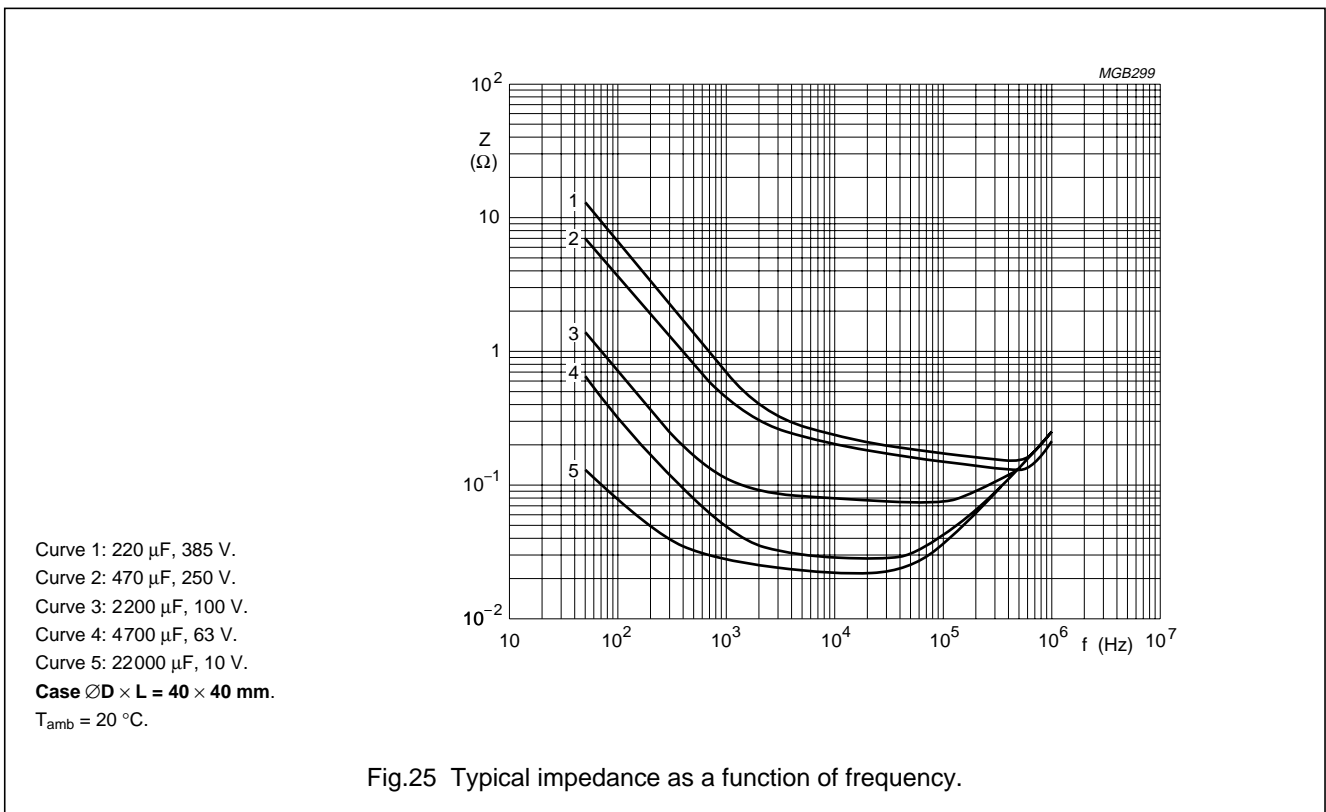
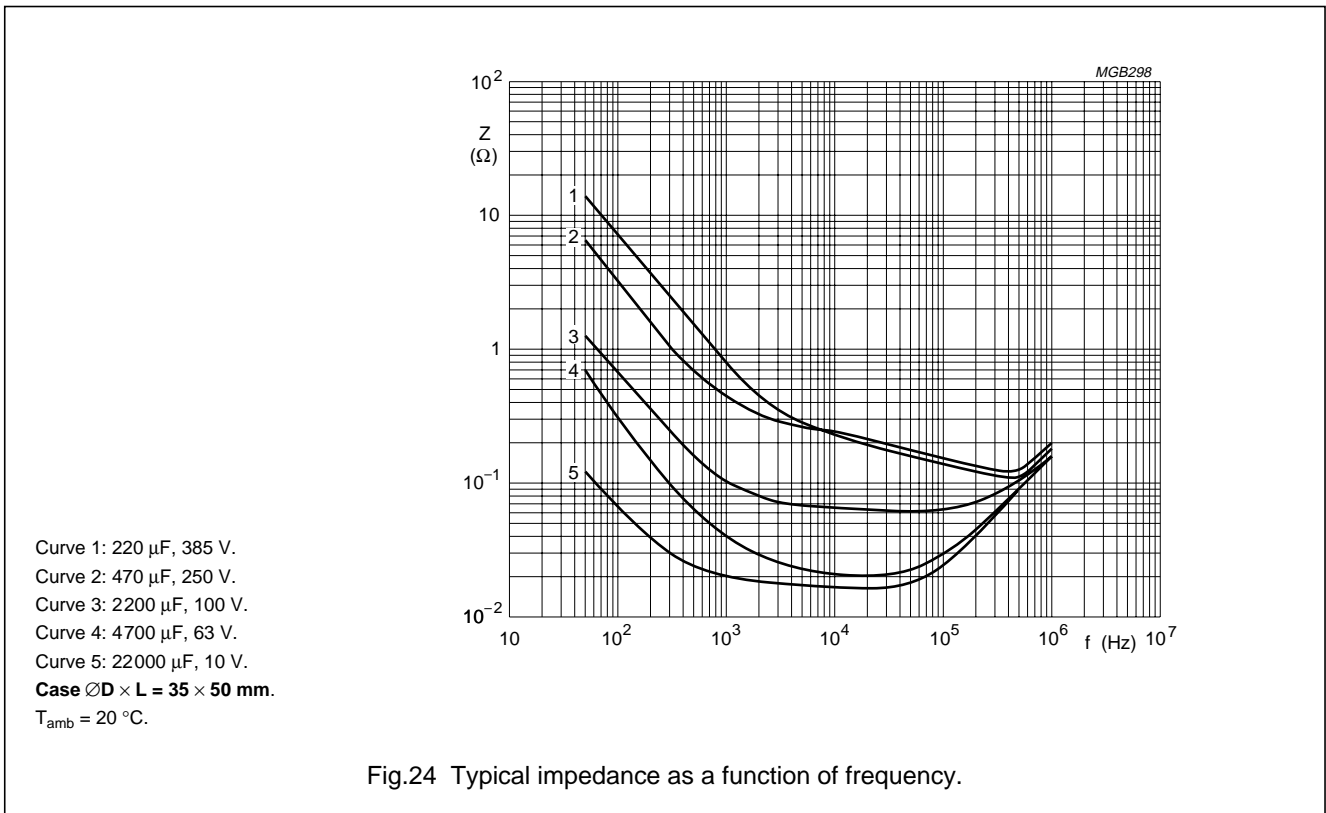

Aluminium electrolytic capacitors  
Power Eurodin Printed Wiring

050/052 PED-PW

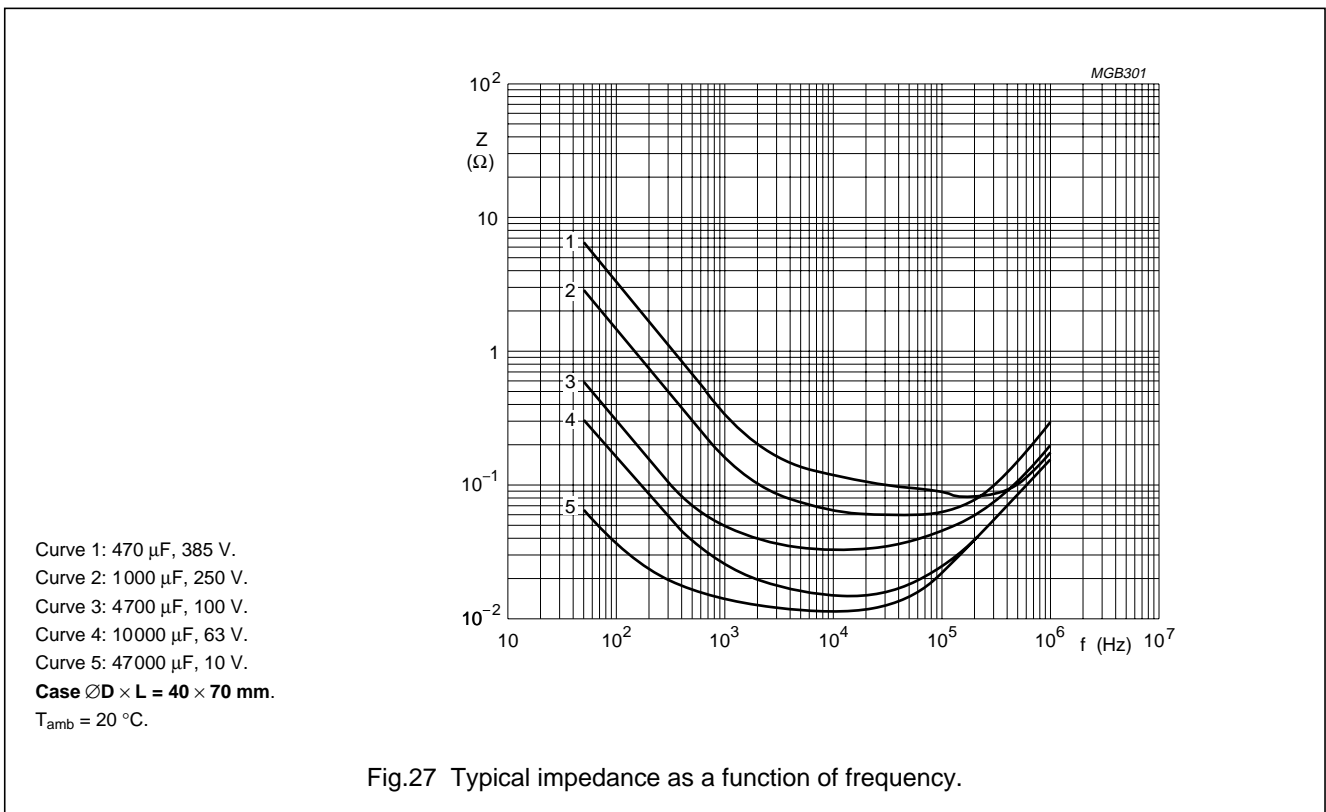
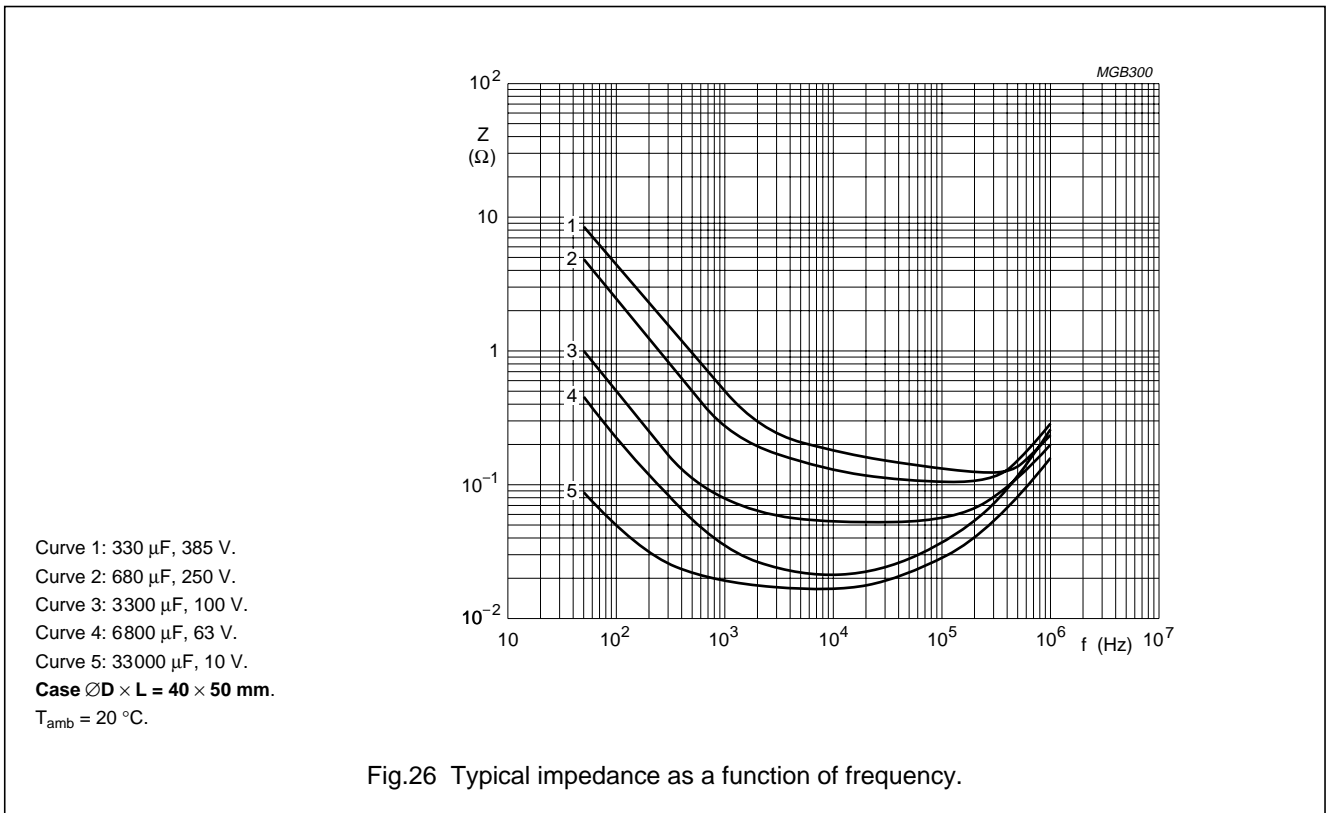

L

# Aluminium electrolytic capacitors

## Power Eurodin Printed Wiring

050/052 PED-PW

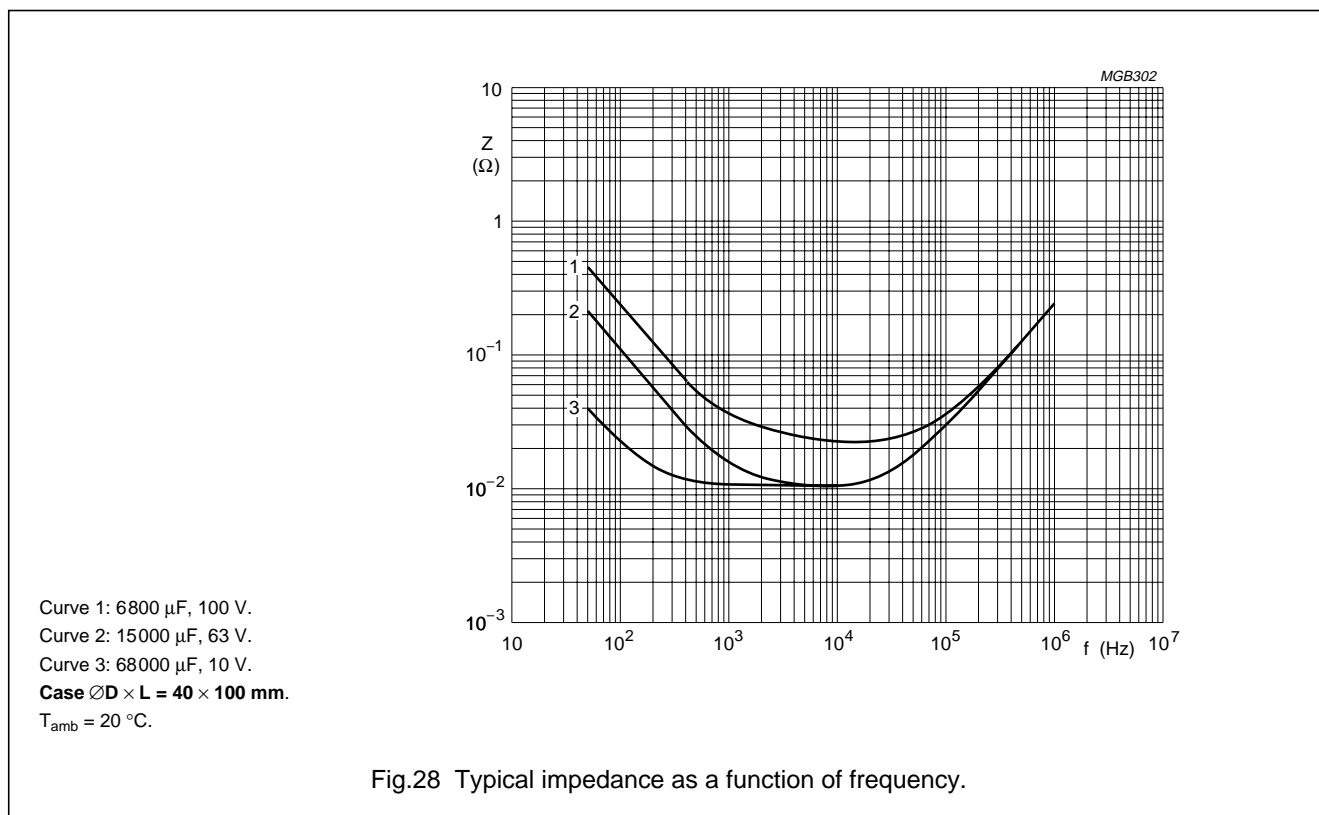

### MARKING

The capacitors are marked (where possible) with the following information:

- Rated capacitance (in  $\mu\text{F}$ )
- Tolerance on rated capacitance (Q for  $-10/+30\%$ )
- Rated voltage (in V)
- Climatic category in accordance with "IEC 68"
- Date code (year and week) in accordance with "IEC 62"
- Code for factory of origin
- Name of manufacturer
- Polarity of the terminals and '-' sign to indicate the negative terminal, visible from the top and/or side of the capacitor
- Code number
- Code for basic specification in accordance with "IEC 384-4-1" and "CECC 30301".

Aluminium electrolytic capacitors  
Power Eurodin Printed Wiring

050/052 PED-PW

**RIPPLE CURRENT AND USEFUL LIFE**

**Table 5** Multiplier of ripple current ( $I_R$ ) as a function of frequency

FREQUENCY (Hz)	$I_R$ MULTIPLIER
50	0.83
100	1.00
200	1.10
400	1.15
1000	1.19
$\geq 2000$	1.20

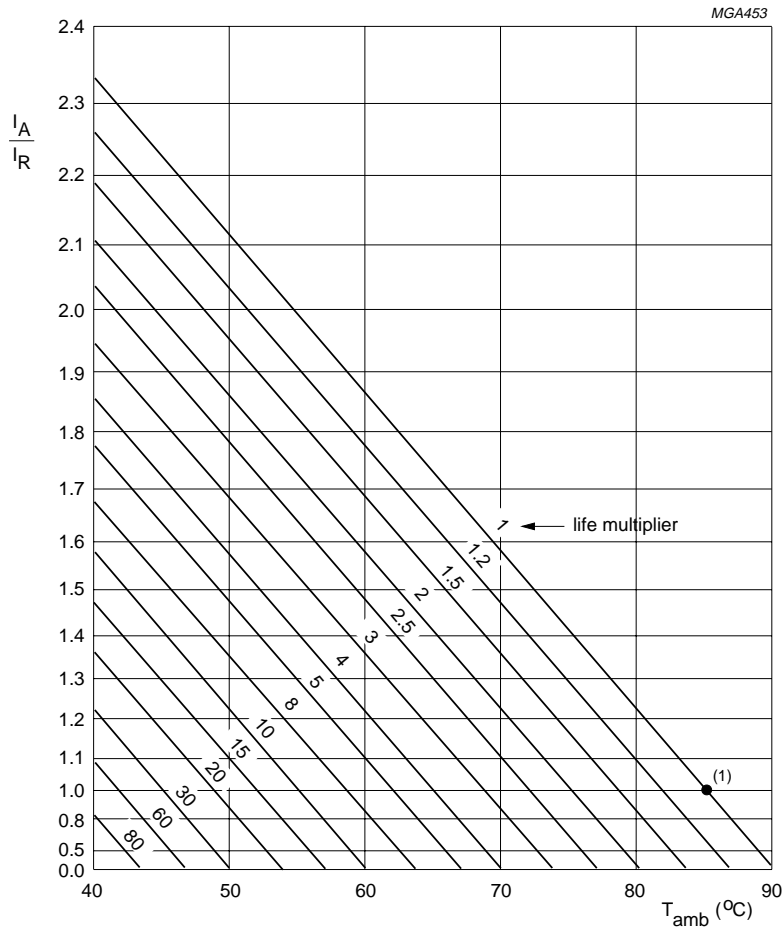

$I_A$  = actual ripple current at 100 Hz and 85 °C.  
 $I_R$  = rated ripple current at 100 Hz and 85 °C.  
 (1) Useful life at 85 °C and  $I_R$  applied: 15000 hours.

Fig.29 Multiplier of useful life as a function of ambient temperature and ripple current load.



# Aluminium electrolytic capacitors

## Power Eurodin Printed Wiring

050/052 PED-PW

### SPECIFIC TESTS AND REQUIREMENTS

General tests and requirements are specified in this handbook, Section "Tests and Requirements".

**Table 6** Test procedures and requirements

TEST		PROCEDURE (quick reference)	REQUIREMENTS
NAME OF TEST	REFERENCE		
Endurance	IEC 384-4/ CECC 30300 subclause 4.13	$T_{amb} = 85\text{ °C}$ ; $U_R$ applied; 5000 hours	$U_R \leq 100\text{ V}$ ; $\Delta C/C: \pm 15\%$ $U_R > 100\text{ V}$ ; $\Delta C/C: \pm 10\%$ $Z \leq 2 \times \text{spec. limit}$ $I_{L5} \leq \text{spec. limit}$
Useful life	CECC 30301 subclause 1.8.1	$T_{amb} = 85\text{ °C}$ ; $U_R$ and $I_R$ applied; 15000 hours	$U_R \leq 100\text{ V}$ ; $\Delta C/C: \pm 45\%$ $U_R > 100\text{ V}$ ; $\Delta C/C: \pm 30\%$ $Z \leq 3 \times \text{spec. limit}$ $I_{L5} \leq \text{spec. limit}$ no short or open circuit, no visible damage total failure percentage: $U_R \leq 100\text{ V}$ : $\leq 1\%$ ; $U_R > 100\text{ V}$ : $\leq 3\%$
Shelf life (storage at high temperature)	IEC 384-4/ CECC 30300 subclause 4.17	$T_{amb} = 85\text{ °C}$ ; no voltage applied; 500 hours after test: $U_R$ to be applied for 30 minutes, 24 to 48 hours before measurement	$\Delta C/C: \pm 10\%$ $I_{L5} \leq 2 \times \text{spec. limit}$