

# Simple MPPT-Based Lead Acid Charger Using bq2031

Lokesh Ghulyani

PMP - BMS Battery Charge

## ABSTRACT

This application report is intended for users designing an MPPT-based lead acid battery charger with the bq2031 battery charger. This report contains a design for charging a 12-A-hr lead acid battery using MPPT (maximum power point tracking) for maximizing charging efficiency for solar applications.

## 1 Introduction

The simplest method of charging a battery from a solar panel is to connect the battery directly to the panel, but this is not the most efficient method. Suppose the panel has a rating of 75 W and produces a current of 4.65 A with a voltage of 16 V at standard test conditions of 25°C temperature and 1000 W/m<sup>2</sup> of insolation. The lead acid battery has a voltage of 12 V; directly connecting the panel to this battery reduces the panel voltage to 12 V and only 55.8 W (12 V and 4.65 A) can be extracted from the panel for charging. A DC/DC converter is required for efficient charging. This application report describes a design using the bq2031 for efficient charging.

## 2 I-V Characteristics of Solar Panel

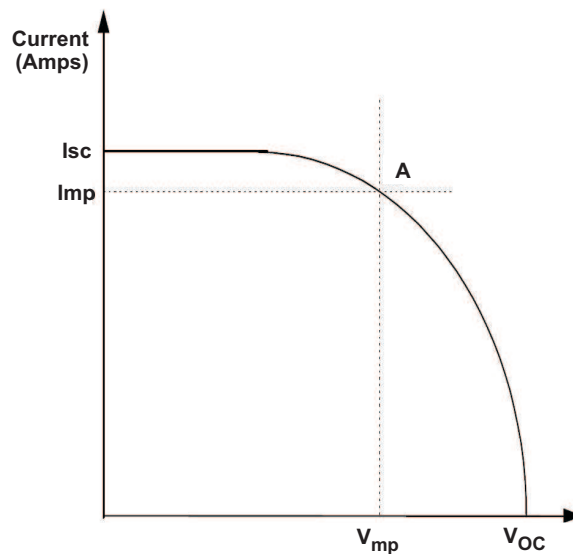

**Figure 1. I-V Characteristics of Solar Panel**

Figure 1 shows the typical characteristics of a solar panel.  $I_{sc}$  is a short-circuit current that flows through the panel when the panel is short circuited. It is the maximum current that can be obtained from the panel.  $V_{oc}$  is the open-circuit voltage at the terminals of the panel.  $V_{mp}$  and  $I_{mp}$  are the voltage and current values at which maximum power can be obtained from the panel. As the sunlight reduces the maximum current ( $I_{sc}$ ) which can be obtained, the maximum current from the panel also reduces. Figure 2 shows variation of I-V characteristics with sunlight. The blue curve connects the points of the maximum power at different values of insolation.

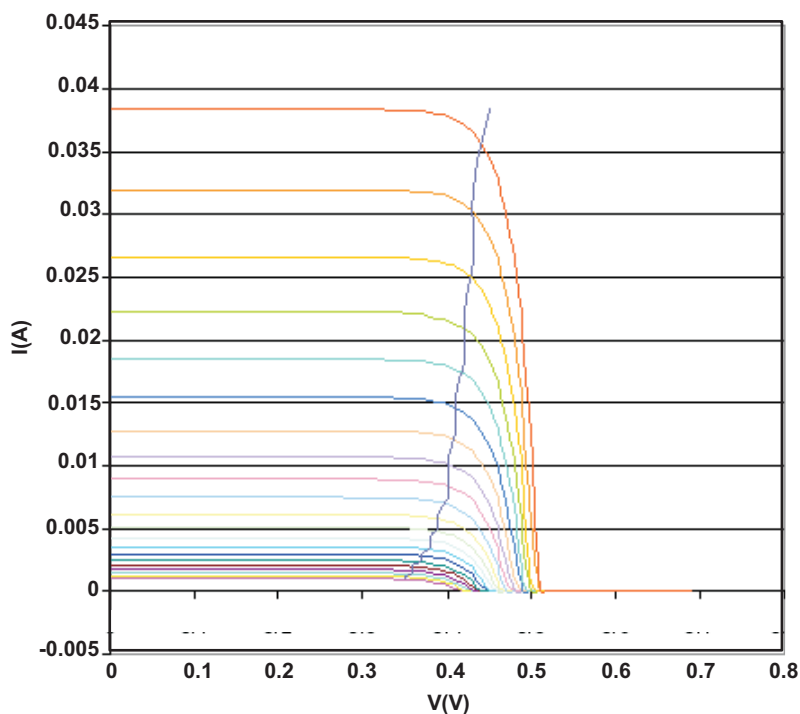

**Figure 2. Variation of I-V Characteristics With Sunlight**

The purpose of the MPPT circuit is to maintain the operating point of the panel at the maximum power point in different sunlight conditions. As seen from [Figure 2](#), the voltage at which maximum power is transferred does not change very much with sunlight. The circuit designed with the bq2031 uses this property to implement MPPT. An extra current control loop is added to reduce the charge current as the sunlight reduces and to maintain panel voltage around the maximum power point voltage.

### 3 bq2031-Based MPPT Charger

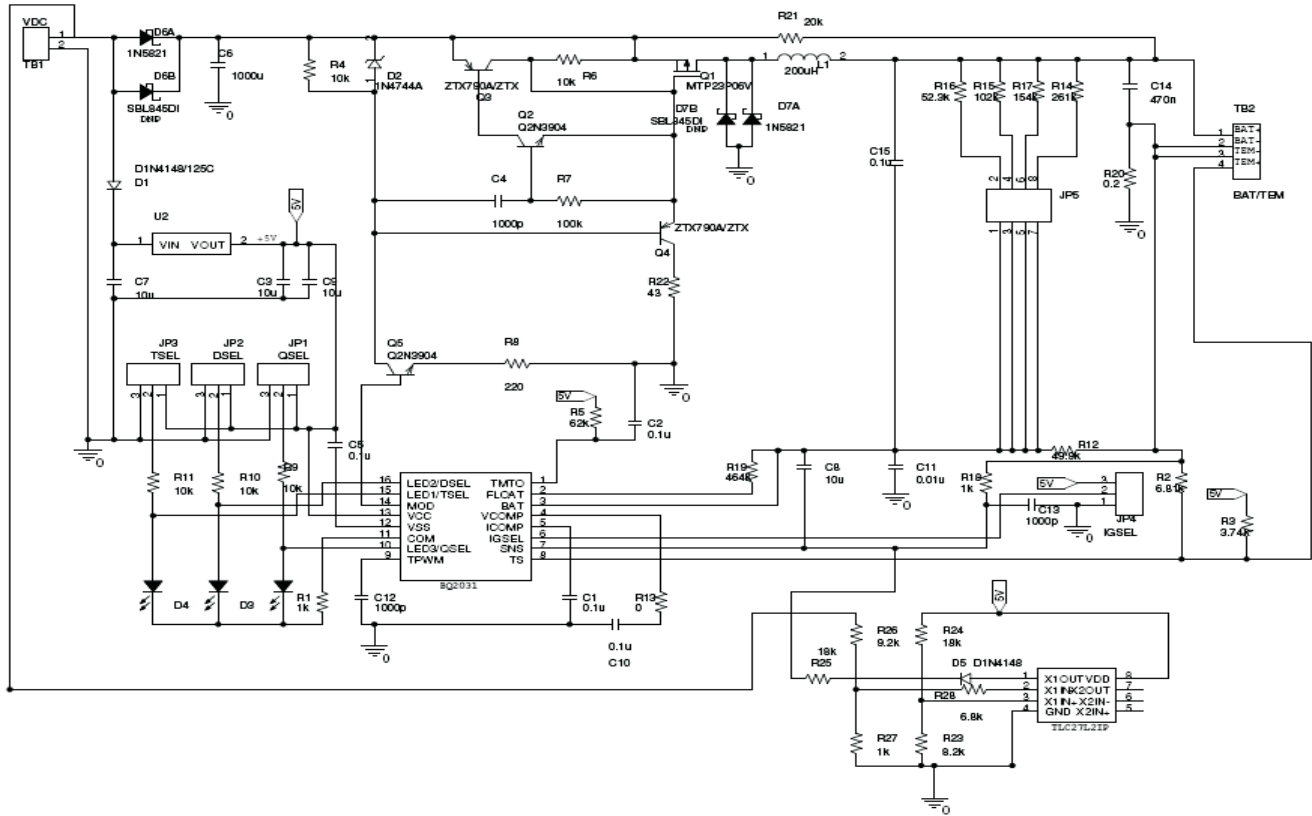

Figure 3. Schematic of MPPT-Based Charger Using bq2031

Figure 3 shows the schematic of a DV2031S2 board with an extra current control loop added to implement the MPPT using the operational amplifier TLC27L2. The bq2031 maintains the charging current by maintaining a voltage of 250 mV at sense resistance R<sub>20</sub>. A reference voltage of 1.565 V is generated using 5 V from U2. The input voltage is compared with the reference voltage to generate an error voltage which is applied at the SNS pin of bq2031 to reduce the charge current. The voltage (V<sub>mp</sub>) at which maximum power can be obtained from the panel is programmed using resistors R<sub>26</sub> and R<sub>27</sub>.  $V_{mp} = 1.565(R_{26}+R_{27})/R_{27}$ . With R<sub>27</sub> = 1 kΩ and R<sub>26</sub> = 9.2 kΩ, V<sub>mp</sub> = 16 V is obtained. TLC27L2 is internally compensated with a bandwidth of 6 kHz at V<sub>dd</sub> = 5 V. Because the bandwidth of TLC27L2 is much less than the switching frequency of bq2031, the extra current control loop remains stable.

Table 1. Input Voltage Regulation by External Loop

S. No.	Vin - Input Voltage (V)	Input Current Limit Imposed by Solar Panel (A)	Vout - Charging Voltage (V)	Iout - Charging Current (A)
1	18.00	1.5	13.00	1.06
2	16.14	0.95	12.97	0.94
3	16.13	0.80	12.92	0.788
4	16.11	0.70	12.88	0.692
5	16.10	0.60	12.84	0.588
6	16.10	0.50	12.80	0.484
7	16.11	0.40	12.76	0.392

The bq2031 in the preceding circuit ([Figure 3](#)) provides a maximum current of 1 A. If the solar panel can provide enough power to charge the battery at 1 A, the external control loop does not come into action. But if the insolation decreases and the solar panel is unable to provide enough power to charge the battery at 1 A, the external control loop reduces the charge current to maintain input voltage at  $V_{mp}$ . The results shown in [Table 1](#) verify the working of the circuit. The voltage readings in bold type represent the condition when the external control loop is reducing the charge current to maintain input at  $V_{mp}$ .

## IMPORTANT NOTICE

Texas Instruments Incorporated and its subsidiaries (TI) reserve the right to make corrections, modifications, enhancements, improvements, and other changes to its products and services at any time and to discontinue any product or service without notice. Customers should obtain the latest relevant information before placing orders and should verify that such information is current and complete. All products are sold subject to TI's terms and conditions of sale supplied at the time of order acknowledgment.

TI warrants performance of its hardware products to the specifications applicable at the time of sale in accordance with TI's standard warranty. Testing and other quality control techniques are used to the extent TI deems necessary to support this warranty. Except where mandated by government requirements, testing of all parameters of each product is not necessarily performed.

TI assumes no liability for applications assistance or customer product design. Customers are responsible for their products and applications using TI components. To minimize the risks associated with customer products and applications, customers should provide adequate design and operating safeguards.

TI does not warrant or represent that any license, either express or implied, is granted under any TI patent right, copyright, mask work right, or other TI intellectual property right relating to any combination, machine, or process in which TI products or services are used. Information published by TI regarding third-party products or services does not constitute a license from TI to use such products or services or a warranty or endorsement thereof. Use of such information may require a license from a third party under the patents or other intellectual property of the third party, or a license from TI under the patents or other intellectual property of TI.

Reproduction of TI information in TI data books or data sheets is permissible only if reproduction is without alteration and is accompanied by all associated warranties, conditions, limitations, and notices. Reproduction of this information with alteration is an unfair and deceptive business practice. TI is not responsible or liable for such altered documentation. Information of third parties may be subject to additional restrictions.

Resale of TI products or services with statements different from or beyond the parameters stated by TI for that product or service voids all express and any implied warranties for the associated TI product or service and is an unfair and deceptive business practice. TI is not responsible or liable for any such statements.

TI products are not authorized for use in safety-critical applications (such as life support) where a failure of the TI product would reasonably be expected to cause severe personal injury or death, unless officers of the parties have executed an agreement specifically governing such use. Buyers represent that they have all necessary expertise in the safety and regulatory ramifications of their applications, and acknowledge and agree that they are solely responsible for all legal, regulatory and safety-related requirements concerning their products and any use of TI products in such safety-critical applications, notwithstanding any applications-related information or support that may be provided by TI. Further, Buyers must fully indemnify TI and its representatives against any damages arising out of the use of TI products in such safety-critical applications.

TI products are neither designed nor intended for use in military/aerospace applications or environments unless the TI products are specifically designated by TI as military-grade or "enhanced plastic." Only products designated by TI as military-grade meet military specifications. Buyers acknowledge and agree that any such use of TI products which TI has not designated as military-grade is solely at the Buyer's risk, and that they are solely responsible for compliance with all legal and regulatory requirements in connection with such use.

TI products are neither designed nor intended for use in automotive applications or environments unless the specific TI products are designated by TI as compliant with ISO/TS 16949 requirements. Buyers acknowledge and agree that, if they use any non-designated products in automotive applications, TI will not be responsible for any failure to meet such requirements.

Following are URLs where you can obtain information on other Texas Instruments products and application solutions:

### Products

Amplifiers	<a href="http://amplifier.ti.com">amplifier.ti.com</a>
Data Converters	<a href="http://dataconverter.ti.com">dataconverter.ti.com</a>
DLP® Products	<a href="http://www.dlp.com">www.dlp.com</a>
DSP	<a href="http://dsp.ti.com">dsp.ti.com</a>
Clocks and Timers	<a href="http://www.ti.com/clocks">www.ti.com/clocks</a>
Interface	<a href="http://interface.ti.com">interface.ti.com</a>
Logic	<a href="http://logic.ti.com">logic.ti.com</a>
Power Mgmt	<a href="http://power.ti.com">power.ti.com</a>
Microcontrollers	<a href="http://microcontroller.ti.com">microcontroller.ti.com</a>
RFID	<a href="http://www.ti-rfid.com">www.ti-rfid.com</a>
RF/IF and ZigBee® Solutions	<a href="http://www.ti.com/lprf">www.ti.com/lprf</a>

### Applications

Audio	<a href="http://www.ti.com/audio">www.ti.com/audio</a>
Automotive	<a href="http://www.ti.com/automotive">www.ti.com/automotive</a>
Broadband	<a href="http://www.ti.com/broadband">www.ti.com/broadband</a>
Digital Control	<a href="http://www.ti.com/digitalcontrol">www.ti.com/digitalcontrol</a>
Medical	<a href="http://www.ti.com/medical">www.ti.com/medical</a>
Military	<a href="http://www.ti.com/military">www.ti.com/military</a>
Optical Networking	<a href="http://www.ti.com/opticalnetwork">www.ti.com/opticalnetwork</a>
Security	<a href="http://www.ti.com/security">www.ti.com/security</a>
Telephony	<a href="http://www.ti.com/telephony">www.ti.com/telephony</a>
Video & Imaging	<a href="http://www.ti.com/video">www.ti.com/video</a>
Wireless	<a href="http://www.ti.com/wireless">www.ti.com/wireless</a>

Mailing Address: Texas Instruments, Post Office Box 655303, Dallas, Texas 75265  
Copyright © 2009, Texas Instruments Incorporated