

## Features

- Wide 3.6V to 24V Input Voltage Rang
- 0.22V Constant Current Sense Voltage
- Directly drive 3~8 Series 1W LED
- Fixed 400KHz Switching Frequency
- Max. 2A Switching Current Capability
- Up to 92% efficiency
- Excellent line and load regulation
- EN PIN TTL shutdown capability
- Internal Optimize Power MOSFET
- Built in LED Open Protection
- Built in Soft-Start Function
- Built in Frequency Compensation
- Built in Thermal Shutdown Function
- Built in Current Limit Function
- Available in SOP8 package

## Applications

- LED Lighting
- Boost constant current driver
- Monitor LED Backlighting
- 7' to 15' LCD Panels

## General Description

The XL6001 regulator is fixed frequency PWM Boost (step-up) LED constant current driver, capable of driving Series 1W LED units with excellent line and load regulation. The regulator is simple to use because it includes internal frequency compensation and a fixed-frequency oscillator so that it requires a minimum number of external components to work.

The XL6001 could directly drive 5~8 Series 1W LED units at  $V_{IN} > 12V$ .

The PWM control circuit is able to adjust the duty ratio linearly from 0 to 90%. An enable function, an over current protection function is built inside. An internal compensation block is built in to minimize external component count.



SOIC-8

Figure1. Package Type of XL6001

**Pin Configurations**

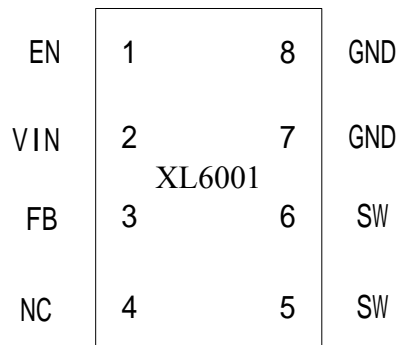

Figure2. Pin Configuration of XL6001 (Top View)

Table 1 Pin Description

Pin Number	Pin Name	Description
1	EN	Enable Pin. Drive EN pin low to turn off the device, drive it high to turn it on. Floating is default high.
2	VIN	Supply Voltage Input Pin. XL6001 operates from a 3.6V to 24V DC voltage. Bypass Vin to GND with a suitably large capacitor to eliminate noise on the input.
3	FB	Feedback Pin (FB). The feedback threshold voltage is 0.22V.
4	NC	No Connected.
5,6	SW	Power Switch Output Pin (SW). Output is the switch node that supplies power to the output.
7,8	GND	Ground Pin.

**Function Block**

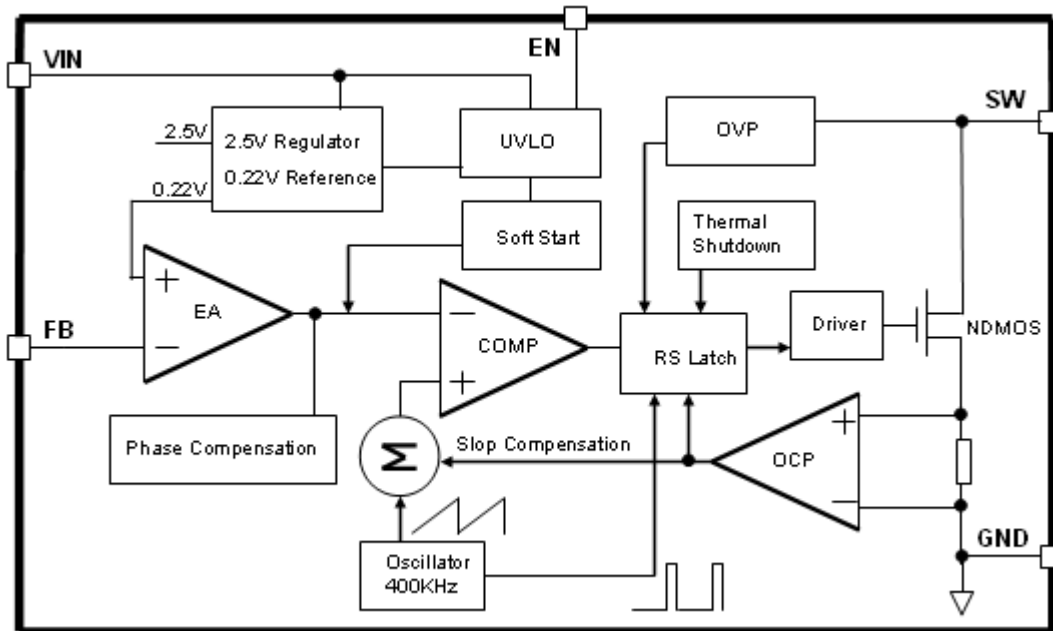

Figure3. Function Block Diagram of XL6001

**Typical Application Circuit**

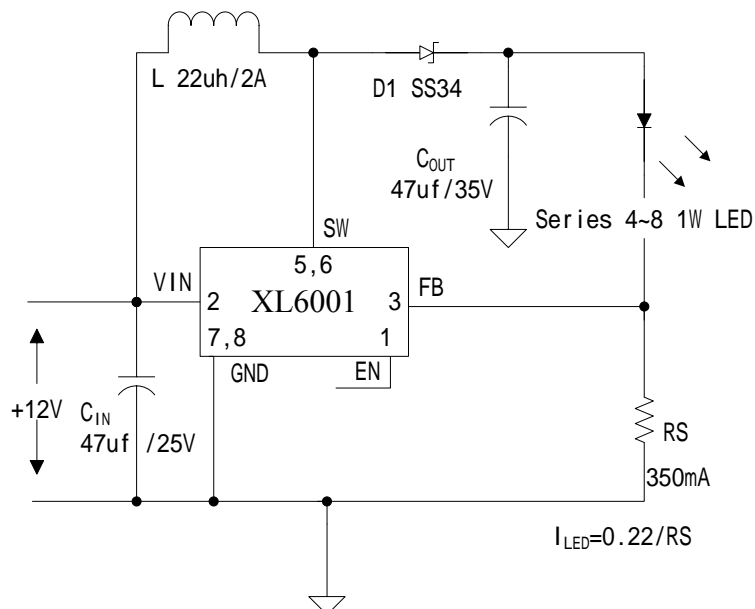

Figure4. XL6001 Typical Application Circuit

400KHz 32V 2A Switching Current Boost LED Constant Current Driver

XL6001

**Ordering Information**

Order Information	Marking ID	Package Type	Packing Type Supplied As
XL6001E1	XL6001E1	SOP-8L	2500 Units on Tape & Reel

XLSEMI Pb-free products, as designated with “E1” suffix in the par number, are RoHS compliant.

**Absolute Maximum Ratings ( Note1 )**

Parameter	Symbol	Value	Unit
Input Voltage	V <sub>in</sub>	-0.3 to 26	V
Feedback Pin Voltage	V <sub>FB</sub>	-0.3 to V <sub>in</sub>	V
EN Pin Voltage	V <sub>EN</sub>	-0.3 to V <sub>in</sub>	V
Output Switch Pin Voltage	V <sub>Output</sub>	-0.3 to 32	V
Power Dissipation	P <sub>D</sub>	Internally limited	mW
Thermal Resistance (SOP8) (Junction to Ambient, No Heatsink, Free Air)	R <sub>JA</sub>	100	°C/W
Operating Junction Temperature	T <sub>J</sub>	-40 to 125	°C
Storage Temperature	T <sub>STG</sub>	-65 to 150	°C
Lead Temperature (Soldering, 10 sec)	T <sub>LEAD</sub>	260	°C
ESD (HBM)		>2000	V

**Note1:** Stresses greater than those listed under Maximum Ratings may cause permanent damage to the device. This is a stress rating only and functional operation of the device at these or any other conditions above those indicated in the operation is not implied. Exposure to absolute maximum rating conditions for extended periods may affect reliability.

**400KHz 32V 2A Switching Current Boost LED Constant Current Driver**

**XL6001**

**XL6001 Electrical Characteristics**

T<sub>a</sub> = 25 °C ; unless otherwise specified.

Symbol	Parameter	Test Condition	Min.	Typ.	Max.	Unit
<i>System parameters test circuit figure4</i>						
VFB	Feedback Voltage	V <sub>in</sub> = 5V to 12V, V <sub>out</sub> =24V I <sub>load</sub> =100mA	209	220	231	mV
Efficiency	η	V <sub>in</sub> =12V , V <sub>out</sub> = 6*1W LED I <sub>out</sub> =0.3A	-	92	-	%

**Electrical Characteristics (DC Parameters)**

V<sub>in</sub> = 12V, GND=0V, V<sub>in</sub> & GND parallel connect a 47uf/25V capacitor; I<sub>out</sub>=50mA, T<sub>a</sub> = 25 °C ; the others floating unless otherwise specified.

Parameters	Symbol	Test Condition	Min.	Typ.	Max.	Unit
Input operation voltage	V <sub>in</sub>		3.6		24	V
Shutdown Supply Current	I <sub>STBY</sub>	V <sub>EN</sub> =0V		70	100	uA
Quiescent Supply Current	I <sub>q</sub>	V <sub>EN</sub> =2V, V <sub>FB</sub> =V <sub>in</sub>		2.5	5	mA
Oscillator Frequency	F <sub>osc</sub>		320	400	480	Khz
Switch Current Limit	I <sub>L</sub>	V <sub>FB</sub> =0		2		A
Output Power NMOS	R <sub>dson</sub>	V <sub>in</sub> =12V, I <sub>sw</sub> =2A		110	120	mohm
EN Pin Threshold	V <sub>EN</sub>	High (Regulator ON) Low (Regulator OFF)		1.4 0.8		V
EN Pin Input Leakage Current	I <sub>H</sub>	V <sub>EN</sub> =2V (ON)		3	10	uA
	I <sub>L</sub>	V <sub>EN</sub> =0V (OFF)		3	10	uA
Max. Duty Cycle	D <sub>MAX</sub>	V <sub>FB</sub> =0V		90		%

**Schottky Diode Selection Table**

Current	Surface Mount	Through Hole	VR (The same as system maximum input voltage)				
			20V	30V	40V	50V	60V
1A			1N5817	1N5818	1N5819		
3A			1N5820	1N5821	1N5822		
			MBR320	MBR330	MBR340	MBR350	MBR360
			SK32	SK33	SK34	SK35	SK36
				30WQ03	30WQ04	30WQ05	
				31DQ03	31DQ04	31DQ05	
			SR302	SR303	SR304	SR305	SR306

**Typical System Application for VIN=5V to driver 2~6 x 1W series LED units**

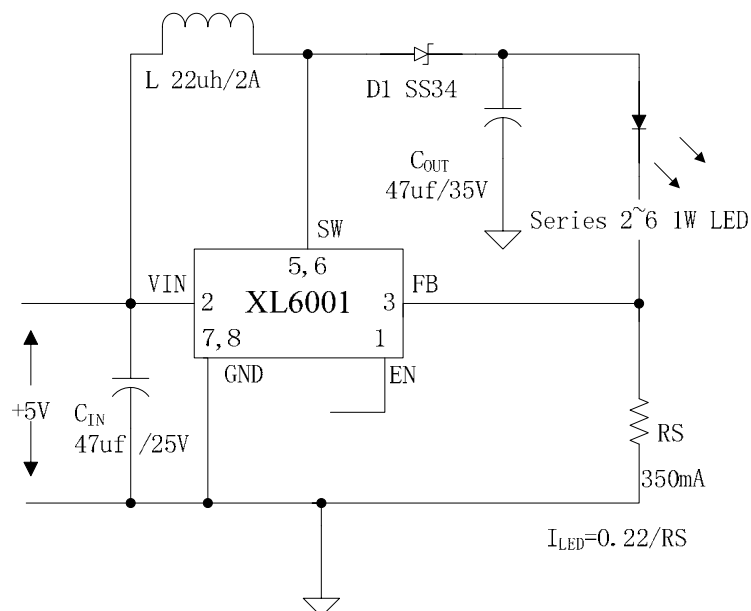

Figure5. XL6001 System Parameters Test Circuit (2~6 x 1W LED)

**Typical System Application for VIN=12V to driver 4~8 x 1W series LED units**

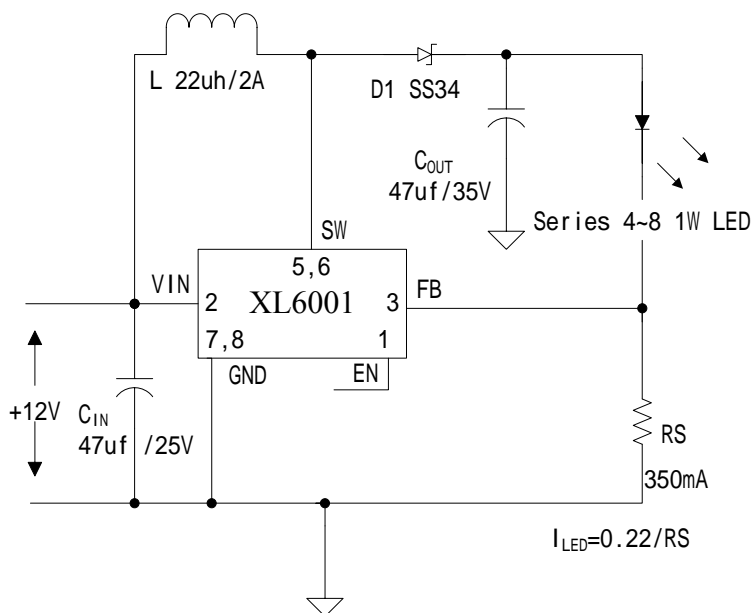

Figure6. XL6001 System Parameters Test Circuit (4~8 x 1W LED)

**Typical System Application for VIN=12V to driver 4~8 x 1W series LED units With PWM Dimming**

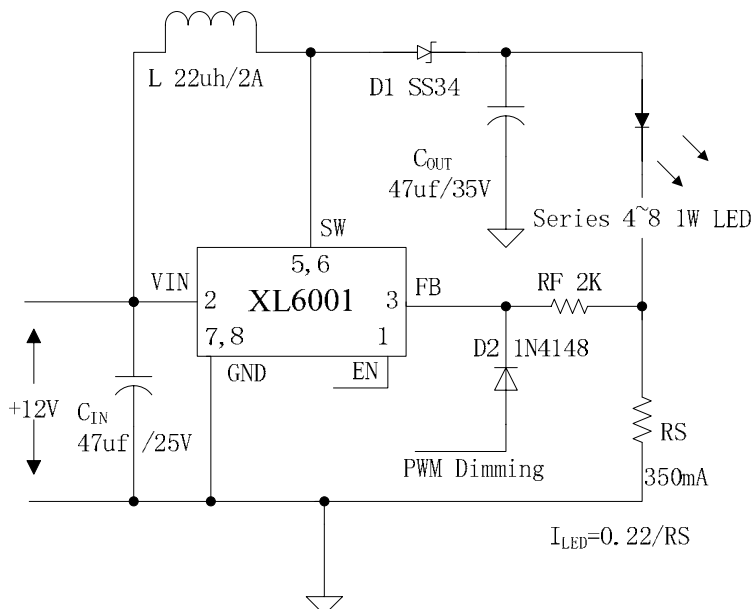

Figure7. XL6001 System Parameters Test Circuit (4~8 x 1W LED with PWM Dimming)

**400KHz 32V 2A Switching Current Boost LED Constant Current Driver** **XL6001**

**Typical System Application for SEPIC Buck-Boost LED Driver**

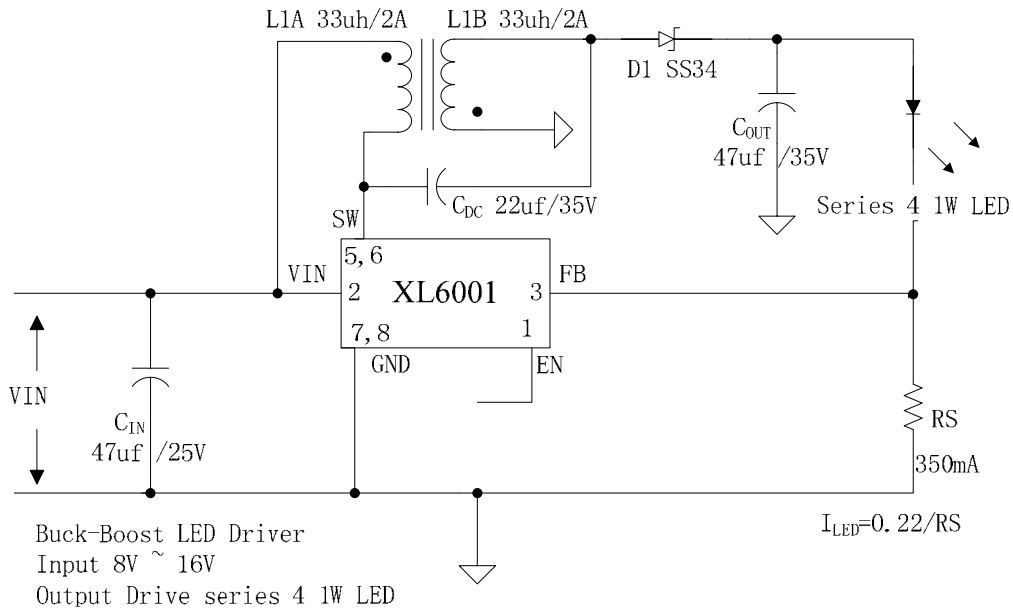

Figure8. XL6001 System Parameters Test Circuit (Buck-Boost LED Driver)



**Package Information**

**SOP8 Package Mechanical Dimensions**

