

### Features

- Ideally Suited for Automatic Insertion
- Complementary PNP Types Available (BC856W-BC858W)
- For Switching and AF Amplifier Applications

### Mechanical Data

- Case: SOT-323, Molded Plastic
- Case material - UL Flammability Rating Classification 94V-0
- Moisture sensitivity: Level 1 per J-STD-020A
- Terminals: Solderable per MIL-STD-202, Method 208
- Pin Connections: See Diagram
- Marking Codes (See Table Below & Diagram on Page 2)
- Ordering & Date Code Information: See Page 2
- Approx. Weight: 0.006 grams

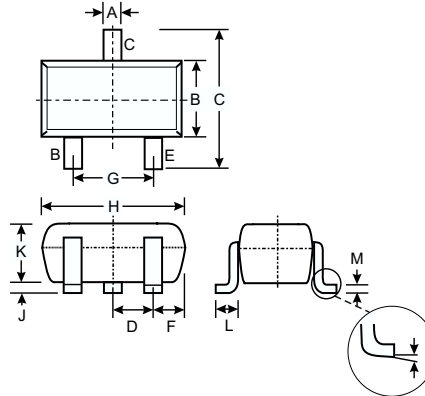

SOT-323		
Dim	Min	Max
A	0.25	0.40
B	1.15	1.35
C	2.00	2.20
D	0.65 Nominal	
E	0.30	0.40
G	1.20	1.40
H	1.80	2.20
J	0.0	0.10
K	0.90	1.00
L	0.25	0.40
M	0.10	0.18
α	0°	8°
All Dimensions in mm		

Marking Code (Note 2)			
Type	Marking	Type	Marking
BC846AW	K1Q	BC847CW	K1M
BC846BW	K1R	BC848AW	K1J, K1E, K1Q
BC847AW	K1E, K1Q	BC848BW	K1K, K1F, K1R
BC847BW	K1F, K1R	BC848CW	K1L, K1M

### Maximum Ratings @ T<sub>A</sub> = 25°C unless otherwise specified

Characteristic	Symbol	Value	Unit
Collector-Base Voltage	BC846 BC847 BC848	80 50 30	V
Collector-Emitter Voltage	BC846 BC847 BC848	65 45 30	V
Emitter-Base Voltage	BC846, BC847 BC848	6.0 5.0	V
Collector Current	I <sub>C</sub>	100	mA
Peak Collector Current	I <sub>CM</sub>	200	mA
Peak Emitter Current	I <sub>EM</sub>	200	mA
Power Dissipation (Note 1)	P <sub>d</sub>	200	mW
Thermal Resistance, Junction to Ambient (Note 1)	R <sub>θJA</sub>	625	°C/W
Operating and Storage Temperature Range	T <sub>J</sub> , T <sub>STG</sub>	-65 to +150	°C

- Notes:
1. Device mounted on FR-4 PCB, 1 inch x 0.85 inch x 0.062 inch; pad layout as shown on Diodes Inc. suggested pad layout document AP02001, which can be found on our website at <http://www.diodes.com/datasheets/ap02001.pdf>.
  2. Current gain subgroup "C" is not available for BC846W.

## Electrical Characteristics @ T<sub>A</sub> = 25°C unless otherwise specified

Characteristic	Symbol	Min	Typ	Max	Unit	Test Condition
Collector-Base Breakdown Voltage (Note 3)	BC846 BC847 BC848 V <sub>(BR)CBO</sub>	80 50 30	— — —	— — —	V	I <sub>C</sub> = 10μA, I <sub>B</sub> = 0
Collector-Emitter Breakdown Voltage (Note 3)	BC846 BC847 BC848 V <sub>(BR)CEO</sub>	65 45 30	— — —	— — —	V	I <sub>C</sub> = 10mA, I <sub>B</sub> = 0
Emitter-Base Breakdown Voltage (Note 3)	BC846, BC847 BC848 V <sub>(BR)EBO</sub>	6 5	—	—	V	I <sub>E</sub> = 1μA, I <sub>C</sub> = 0
DC Current Gain	Current Gain Group A B C (Note 3) h <sub>FE</sub>	110 200 420	180 290 520	220 450 800	—	V <sub>CE</sub> = 5.0V, I <sub>C</sub> = 2.0mA
Collector-Emitter Saturation Voltage (Note 3)	V <sub>CE(SAT)</sub>	—	90 200	250 600	mV	I <sub>C</sub> = 10mA, I <sub>B</sub> = 0.5mA I <sub>C</sub> = 100mA, I <sub>B</sub> = 5.0mA
Base-Emitter Saturation Voltage (Note 3)	V <sub>BE(SAT)</sub>	—	700 900	—	mV	I <sub>C</sub> = 10mA, I <sub>B</sub> = 0.5mA I <sub>C</sub> = 100mA, I <sub>B</sub> = 5.0mA
Base-Emitter Voltage (Note 3)	V <sub>BE(ON)</sub>	580 —	660 —	700 770	mV	V <sub>CE</sub> = 5.0V, I <sub>C</sub> = 2.0mA V <sub>CE</sub> = 5.0V, I <sub>C</sub> = 10mA
Collector-Cutoff Current (Note 3)	I <sub>CBO</sub> I <sub>CBO</sub>	— —	— —	15 5.0	nA μA	V <sub>CB</sub> = 30V V <sub>CB</sub> = 30V, T <sub>A</sub> = 150°C
Gain Bandwidth Product	f <sub>T</sub>	100	300	—	MHz	V <sub>CE</sub> = 5.0V, I <sub>C</sub> = 10mA, f = 100MHz
Collector-Base Capacitance	C <sub>CBO</sub>	—	3.0	4.5	pF	V <sub>CB</sub> = 10V, f = 1.0MHz
Noise Figure	NF	—	—	10	dB	V <sub>CE</sub> = 5V, I <sub>C</sub> = 200μA, R <sub>S</sub> = 2.0kΩ, f = 1.0kHz, Δf = 200Hz

## Ordering Information (Note 4)

Device	Packaging	Shipping
BC84xxW-7*	SOT-323	3000/Tape & Reel

Notes: 3. Short duration pulse test to minimize self-heating effect.

4. For Packaging Details, go to our website at <http://www.diodes.com/datasheets/ap02007.pdf>.

\*xx = device type, e.g. BC846AW-7.

## Marking Information

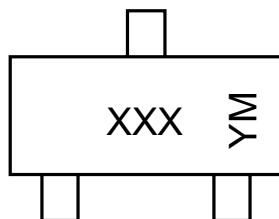

XXX = Product Type Marking Code (See Page 1), e.g. K1Q = BC846AW  
 YM = Date Code Marking  
 Y = Year ex: N = 2002  
 M = Month ex: 9 = September

### Date Code Key

Year	1998	1999	2000	2001	2002	2003	2004
Code	J	K	L	M	N	P	R

Month	Jan	Feb	March	Apr	May	Jun	Jul	Aug	Sep	Oct	Nov	Dec
Code	1	2	3	4	5	6	7	8	9	O	N	D