

HP InfoTech

CodeVisionAVR

VERSION 2.04.4

User Manual

CodeVisionAVR V2.04.4 User Manual

Revision 20/8.2009

Copyright © 1998-2009 Pavel Haiduc and HP InfoTech S.R.L. All rights reserved.

No part of this document may be reproduced in any form except by written permission of the author.

All rights of translation reserved.

CodeVisionAVR

Table of Contents

Table of Contents	2
1. Introduction.....	9
1.1 Credits	10
2. The CodeVisionAVR Integrated Development Environment	11
2.1 Using the Integrated Development Environment Workspace	11
2.2 Working with Files	21
2.2.1 Creating a New File	21
2.2.2 Opening an Existing File.....	22
2.2.3 Files History	22
2.2.4 Editing a File	23
2.2.4.1 Searching/Replacing Text.....	24
2.2.4.2 Setting Bookmarks.....	24
2.2.4.3 Jumping to a Symbol Definition or Declaration.....	24
2.2.4.4 Jumping to a Specific Line Number in the Edited File	25
2.2.4.5 Printing a Text Selection.....	25
2.2.4.6 Indenting/Unindenting a Text Selection	25
2.2.4.7 Commenting/Uncommenting a Text Selection	25
2.2.4.8 Match Braces	25
2.2.4.9 Inserting Special Characters in the Text.....	26
2.2.4.10 Using the Auto Complete Functions	27
2.2.4.11 Using Code Folding	27
2.2.5 Saving a File	28
2.2.6 Renaming a File.....	28
2.2.7 Printing a File.....	29
2.2.8 Closing a File	29
2.2.9 Closing Multiple Files.....	30

CodeVisionAVR

2.2.10 Using the Code Templates	31
2.2.11 Using the Clipboard History	32
2.3 Working with Projects	33
2.3.1 Creating a New Project.....	33
2.3.3 Adding Notes or Comments to the Project	36
2.3.4 Configuring the Project	37
2.3.4.1 Adding or Removing a File from the Project.....	37
2.3.4.2 Setting the Project Output Directories	39
2.3.4.3 Setting the C Compiler Options	40
2.3.4.4 Executing an User Specified Program before Build	50
2.3.4.5 Transferring the Compiled Program to the AVR Chip after Build	51
2.3.4.6 Executing an User Specified Program after Build	53
2.3.5 Obtaining an Executable Program.....	55
2.3.5.1 Checking Syntax.....	55
2.3.5.2 Compiling the Project.....	56
2.3.5.3 Building the Project.....	58
2.3.5.4 Cleaning Up the Project Output Directories.....	62
2.3.5.5 Using the Code Navigator.....	63
2.3.5.6 Using the Code Information.....	64
2.3.5.7 Using the Function Call Tree	65
2.3.6 Closing a Project.....	66
2.4 Tools	67
2.4.1 The AVR Studio Debugger	67
2.4.2 The AVR Chip Programmer.....	68
2.4.3 The Serial Communication Terminal	71
2.4.4 Executing User Programs.....	72
2.4.5 Configuring the Tools Menu	72
2.5 IDE Settings.....	74

CodeVisionAVR

2.5.1 The View Menu	74
2.5.2 General IDE Settings	74
2.5.3 Configuring the Editor	75
2.5.3.1 General Editor Settings.....	75
2.5.3.2 Editor Text Settings	77
2.5.3.3 Syntax Highlighting Settings.....	78
2.5.3.4 Auto Complete Settings	79
2.5.4 Setting the Debugger Path	80
2.5.5 AVR Chip Programmer Setup	81
2.5.6 Serial Communication Terminal Setup.....	83
2.6 Accessing the Help.....	84
2.7 Transferring or Deactivating the License.....	84
2.8 Connecting to HP InfoTech's Web Site	85
2.9 Quitting the CodeVisionAVR IDE	85
3. CodeVisionAVR C Compiler Reference	86
3.1 The C Preprocessor	86
3.2 Comments	90
3.3 Reserved Keywords	91
3.4 Identifiers	92
3.5 Data Types	92
3.6 Constants.....	93
3.7 Variables.....	95
3.7.1 Specifying the RAM and EEPROM Storage Address for Global Variables.....	97
3.7.2 Bit Variables.....	98
3.7.3 Allocation of Variables to Registers.....	99
3.7.4 Structures	100
3.7.5 Unions.....	104
3.7.6 Enumerations.....	106

CodeVisionAVR

3.8 Defining Data Types	107
3.9 Type Conversions.....	108
3.10 Operators.....	109
3.11 Functions	110
3.12 Pointers.....	111
3.13 Compiler Directives	114
3.14 Accessing the I/O Registers	118
3.14.1 Bit level access to the I/O Registers.....	121
3.15 Accessing the EEPROM.....	123
3.16 Using Interrupts	124
3.17 RAM Memory Organization and Register Allocation.....	126
3.18 Using an External Startup Assembly File	129
3.19 Including Assembly Language in Your Program	131
3.19.1 Calling Assembly Functions from C.....	132
3.20 Creating Libraries	133
3.21 Using the AVR Studio Debugger.....	136
3.22 Compiling the Sample Code of the ATxmega Application Notes from Atmel	137
3.23 Hints.....	137
3.24 Limitations.....	137
4. Library Functions Reference.....	138
4.1 Character Type Functions	139
4.2 Standard C Input/Output Functions.....	140
4.3 Standard Library Functions	148
4.4 Mathematical Functions.....	150
4.5 String Functions.....	153
4.6 Variable Length Argument Lists Macros	158
4.7 Non-local Jump Functions	159
4.8 BCD Conversion Functions	161

CodeVisionAVR

4.9 Gray Code Conversion Functions	161
4.10 Memory Access Macros	162
4.11 LCD Functions	163
4.11.1 LCD Functions for displays with up to 2x40 characters	163
4.11.2 LCD Functions for displays with 4x40 characters	166
4.11.3 LCD Functions for displays connected in 8 bit memory mapped mode	168
4.12 I ² C Bus Functions	170
4.12.1 National Semiconductor LM75 Temperature Sensor Functions	172
4.12.2 Maxim/Dallas Semiconductor DS1621 Thermometer/ Thermostat Functions	175
4.12.3 Philips PCF8563 Real Time Clock Functions.....	178
4.12.4 Philips PCF8583 Real Time Clock Functions.....	181
4.12.5 Maxim/Dallas Semiconductor DS1307 Real Time Clock Functions.....	184
4.13 Maxim/Dallas Semiconductor DS1302 Real Time Clock Functions.....	186
4.14 1 Wire Protocol Functions	188
4.14.1 Maxim/Dallas Semiconductor DS1820/DS18S20 Temperature Sensors Functions.....	190
4.14.2 Maxim/Dallas Semiconductor DS18B20 Temperature Sensor Functions.....	194
4.14.3 Maxim/Dallas Semiconductor DS2430 EEPROM Functions.....	197
4.14.4 Maxim/Dallas Semiconductor DS2433 EEPROM Functions.....	200
4.15 SPI Functions	203
4.16 Power Management Functions.....	207
4.17 Delay Functions.....	208
4.18 MMC/SD/SD HC FLASH Memory Card Driver Functions.....	209
4.19 FAT Access Functions.....	218
5. CodeWizardAVR Automatic Program Generator	244
5.1 Setting the AVR Chip Options	247
5.2 Setting the External SRAM.....	249
5.3 Setting the Input/Output Ports	251
5.4 Setting the External Interrupts	252

CodeVisionAVR

5.5 Setting the Timers/Counters.....	254
5.6 Setting the UART or USART	260
5.7 Setting the Analog Comparator	263
5.8 Setting the Analog-Digital Converter	265
5.9 Setting the ATmega406 Voltage Reference.....	267
5.10 Setting the ATmega406 Coulomb Counter	268
5.11 Setting the SPI Interface.....	270
5.12 Setting the Universal Serial Interface - USI.....	271
5.13 Setting the I ² C Bus	273
5.13.1 Setting the LM75 devices	274
5.13.2 Setting the DS1621 devices	275
5.13.3 Setting the PCF8563 devices	276
5.13.4 Setting the PCF8583 devices	277
5.13.5 Setting the DS1307 devices	278
5.14 Setting the 1 Wire Bus.....	280
5.15 Setting the 2 Wire Bus.....	282
5.16 Setting the CAN Controller	283
5.17 Setting the ATmega169/329/3290/649/6490 LCD Controller.....	285
5.18 Setting the LCD	286
5.19 Setting the USB Controller	287
5.20 Setting Bit-Banged Peripherals	288
5.21 Specifying the Project Information.....	289
6. License Agreement	290
6.1 Software License	290
6.2 Liability Disclaimer	290
6.3 Restrictions	290
6.4 Operating License	290
6.5 Back-up and Transfer	291

CodeVisionAVR

6.6 Terms.....	291
6.7 Other Rights and Restrictions.....	291
7. Technical Support and Updates	292
8. Contact Information	293

CodeVisionAVR

1. Introduction

CodeVisionAVR is a C cross-compiler, Integrated Development Environment and Automatic Program Generator designed for the Atmel AVR family of microcontrollers.

The program is designed to run under the 2000, XP, Vista and Windows 7 32bit and 64bit operating systems.

The C cross-compiler implements all the elements of the ANSI C language, as allowed by the AVR architecture, with some features added to take advantage of specificity of the AVR architecture and the embedded system needs.

The compiled COFF object files can be C source level debugged, with variable watching, using the Atmel AVR Studio debugger.

The Integrated Development Environment (IDE) has built-in AVR Chip In-System Programmer software that enables the automatical transfer of the program to the microcontroller chip after successful compilation/assembly. The In-System Programmer software is designed to work in conjunction with the Atmel STK500, STK600, AVRISP, AVRISP MkII, AVR Dragon, JTAGICE MkII, AVRProg (AVR910 application note), Kanda Systems STK200+, STK300, Dontronics DT006, Vogel Elektronik VTEC-ISP, Futurlec JRAVR and MicroTronics' ATCPU, Mega2000 development boards. For debugging embedded systems, which employ serial communication, the IDE has a built-in Terminal.

Besides the standard C libraries, the CodeVisionAVR C compiler has dedicated libraries for:

- Alphanumeric LCD modules
- Philips I²C bus
- National Semiconductor LM75 Temperature Sensor
- Philips PCF8563, PCF8583, Maxim/Dallas Semiconductor DS1302 and DS1307 Real Time Clocks
- Maxim/Dallas Semiconductor 1 Wire protocol
- Maxim/Dallas Semiconductor DS1820, DS18S20 and DS18B20 Temperature Sensors
- Maxim/Dallas Semiconductor DS1621 Thermometer/Thermostat
- Maxim/Dallas Semiconductor DS2430 and DS2433 EEPROMs
- SPI
- Power management
- Delays
- Gray code conversion
- MMC/SD/SD HC FLASH memory cards low level access
- FAT acces on MMC/SD/SD HC FLASH memory cards.

CodeVisionAVR also contains the CodeWizardAVR Automatic Program Generator, that allows you to write, in a matter of minutes, all the code needed for implementing the following functions:

- External memory access setup
- Chip reset source identification
- Input/Output Port initialization
- External Interrupts initialization
- Timers/Counters initialization
- Watchdog Timer initialization
- UART (USART) initialization and interrupt driven buffered serial communication
- Analog Comparator initialization
- ADC initialization
- SPI Interface initialization
- Two Wire Interface initialization
- CAN Interface initialization
- I²C Bus, LM75 Temperature Sensor, DS1621 Thermometer/Thermostat and PCF8563, PCF8583, DS1302, DS1307 Real Time Clocks initialization
- 1 Wire Bus and DS1820/DS18S20 Temperature Sensors initialization
- LCD module initialization.

CodeVisionAVR

This product is © Copyright 1998-2009 Pavel Haiduc and HP InfoTech S.R.L., all rights reserved. The MMC, SD, SD HC and FAT File System libraries are based on the FatFS open source project from <http://elm-chan.org> © Copyright 2006-2009 ChaN, all rights reserved.

1.1 Credits

The HP InfoTech team wishes to thank:

- Mr. Jack Tidwell for his great help in the implementation of the floating point routines
- Mr. Yuri G. Salov for his excellent work in improving the Mathematical Functions Library
- Mr. Olivier Wullemin and Mr. Franc Marx for their help in beta testing
- Mr. Lee H. Theusch for his support in improving the compiler
- Mr. ChaN from Electronic Lives Mfg. <http://elm-chan.org> for the open source **MMC/SD/SD HC FLASH Memory Card Driver** and **FAT File System** functions.

CodeVisionAVR

2. The CodeVisionAVR Integrated Development Environment

2.1 Using the Integrated Development Environment Workspace

The CodeVisionAVR IDE workspace consist from several windows that may be docked to the main application window or left floating on the desktop to suit the user's preferences.

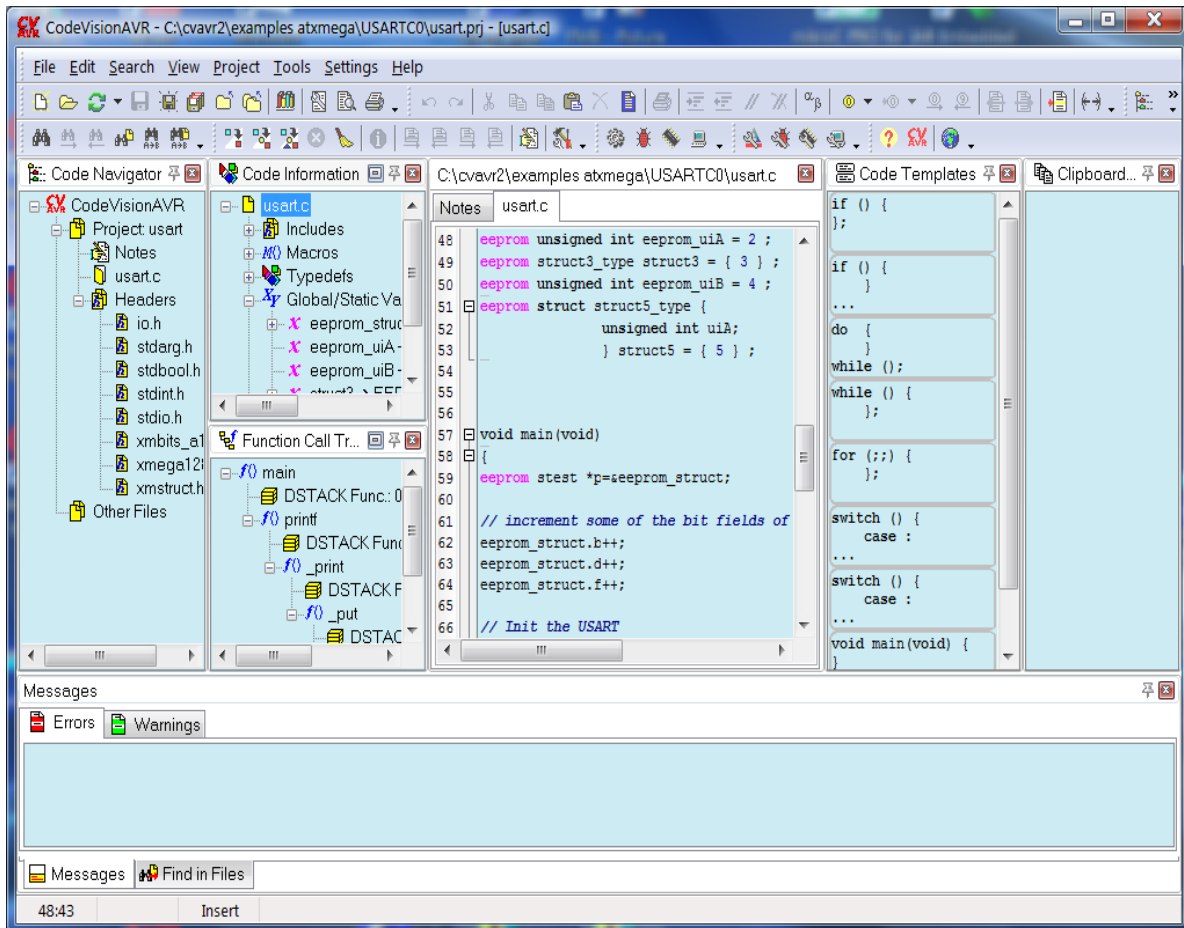

CodeVisionAVR

In order to undock a window, its top bar must be clicked with the left mouse button and keeping the button pressed, dragged to any suitable position on the desktop.

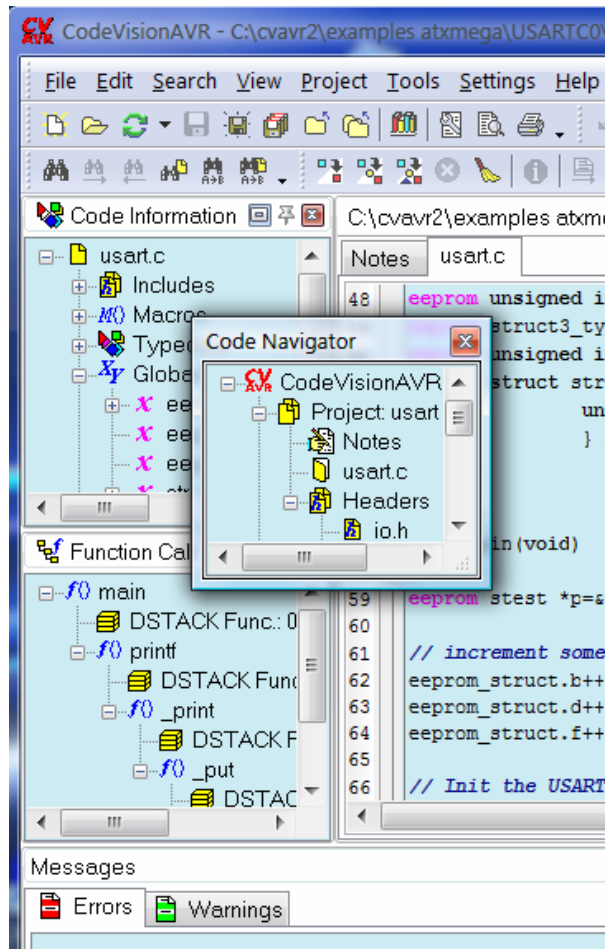

The window can be resized by dragging its right and bottom margins with the left mouse button pressed.

CodeVisionAVR

An undocked window can be docked to any position in the main application window or even to another docked window.

In order to dock the window, its top bar must be dragged, keeping the left mouse button pressed, until its future docked position is outlined like in the picture below:

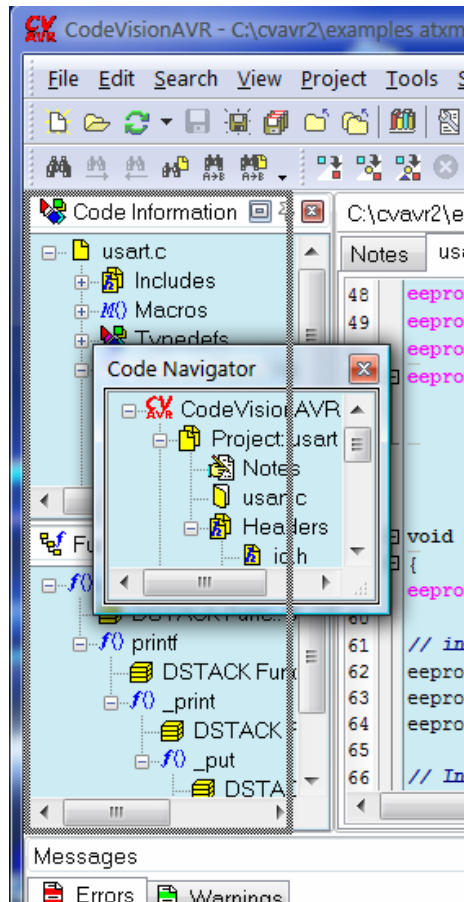

When the mouse button will be released, the window will become docked.

CodeVisionAVR

If the window is desired to be docked to another docked window, the future position of the window will be that of a tabbed page, like in the picture below:

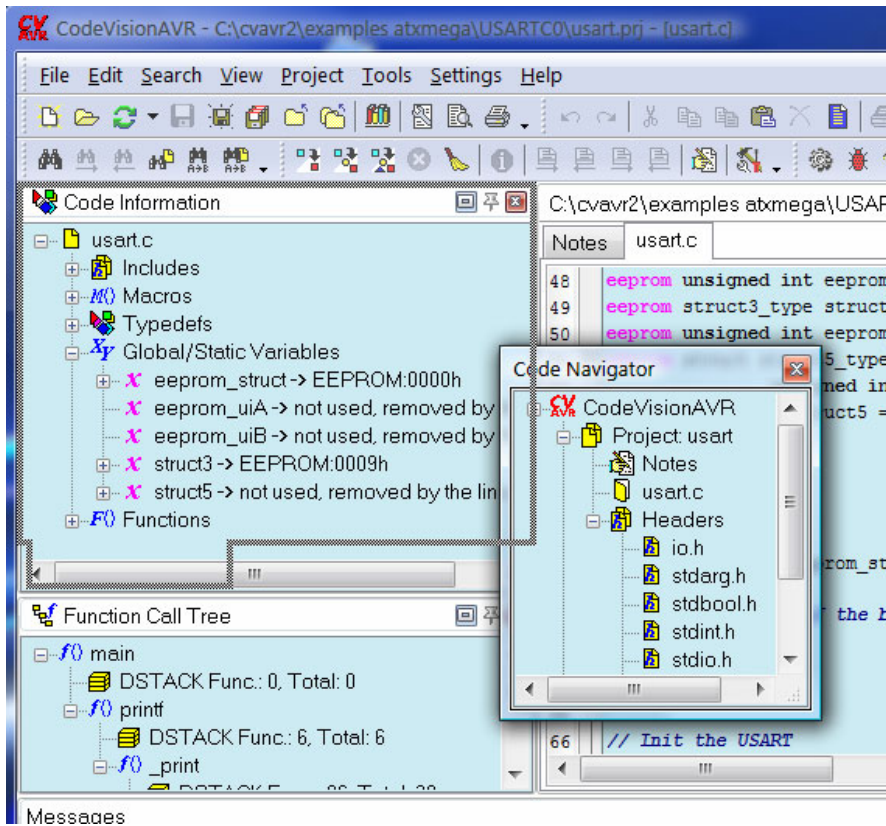

Once docked, the window will become a tabbed page:

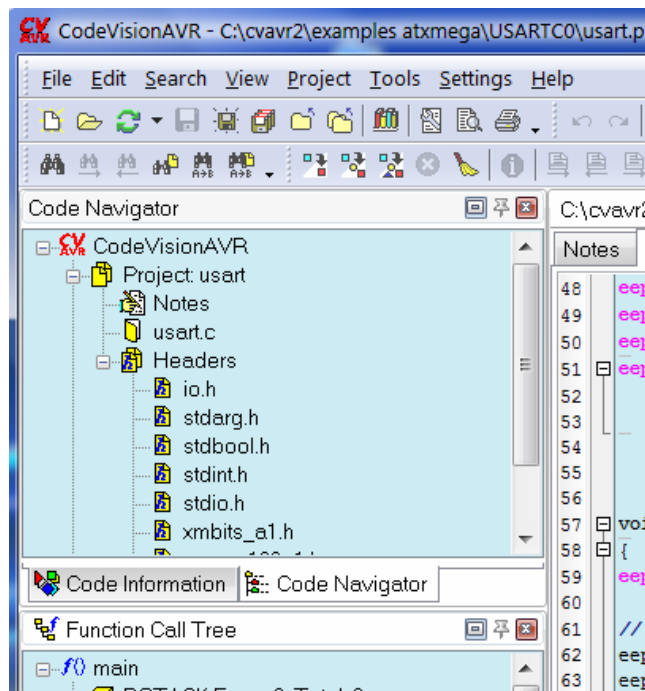

To undock a single tabbed page, the bottom tab must be dragged with the mouse.

CodeVisionAVR

If the window's top bar will be dragged with the mouse, the whole tabbed window will be undocked:

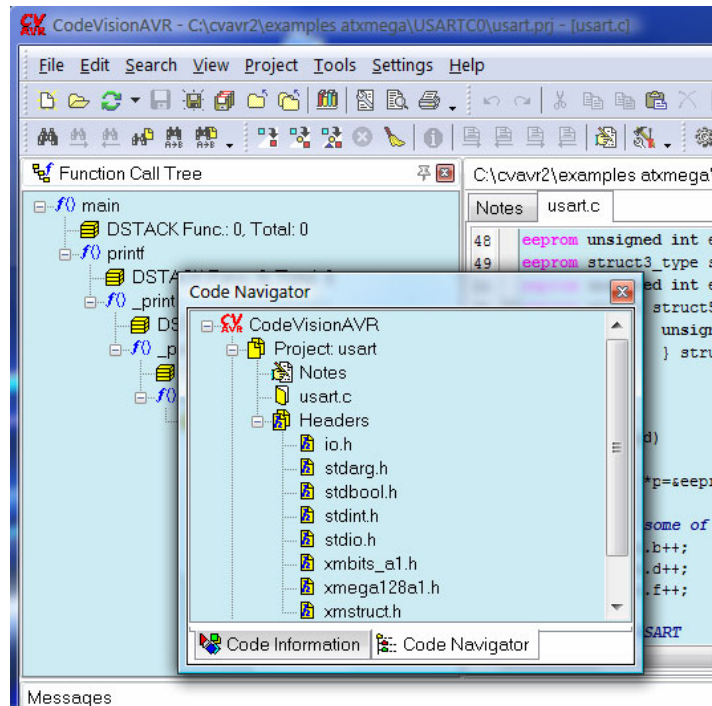

A workspace window can be hidden by left clicking on its  icon, by pressing its corresponding button on the **View** toolbar or by using the **View** menu.

A window's corresponding button on the **View** toolbar must be pressed or the **View** menu must be used in order to make a hidden window visible again.

Clicking on the  icon will make the docked window temporarily hidden, its position will be displayed by a vertical bar located on the left or right of the docking site:

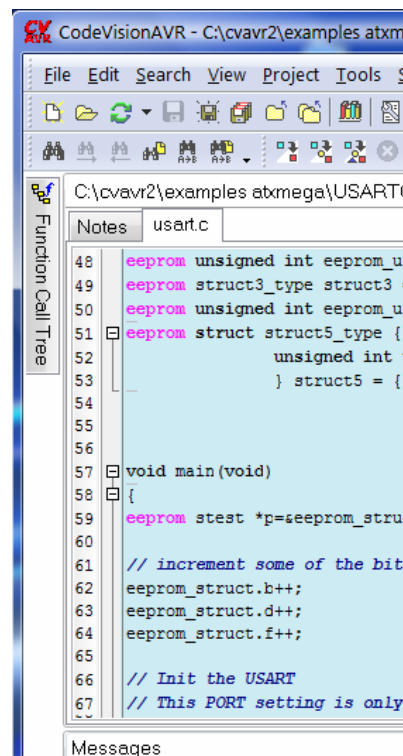

CodeVisionAVR

If the user will place the mouse cursor on the vertical bar, the hidden window will be displayed for a short amount of time

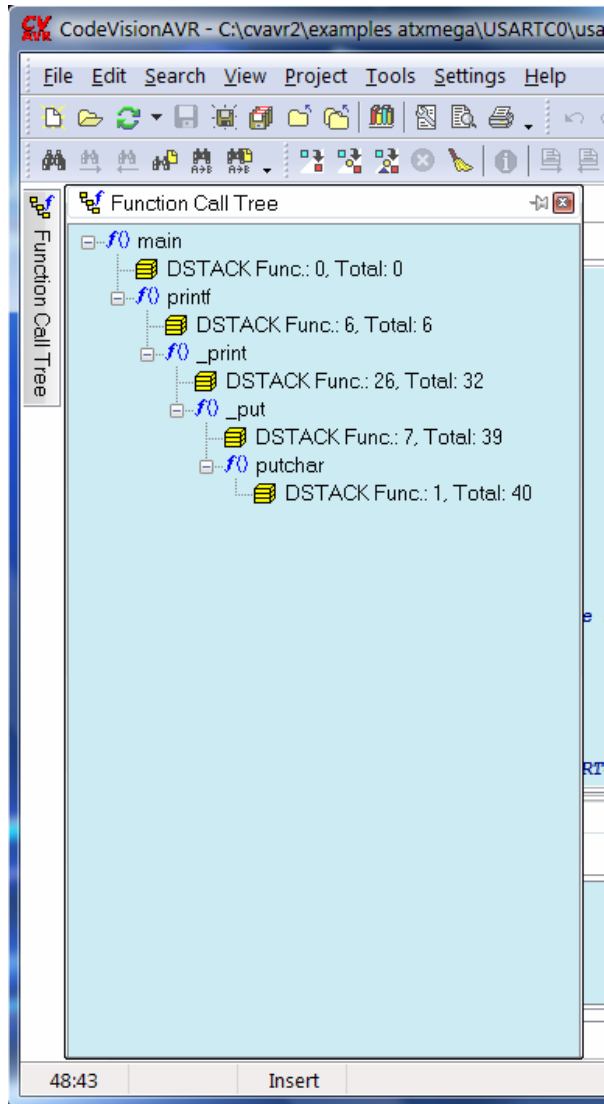



and then will become hidden again.

In order to lock the temporarily displayed window in position, the user must click on the  icon.

CodeVisionAVR

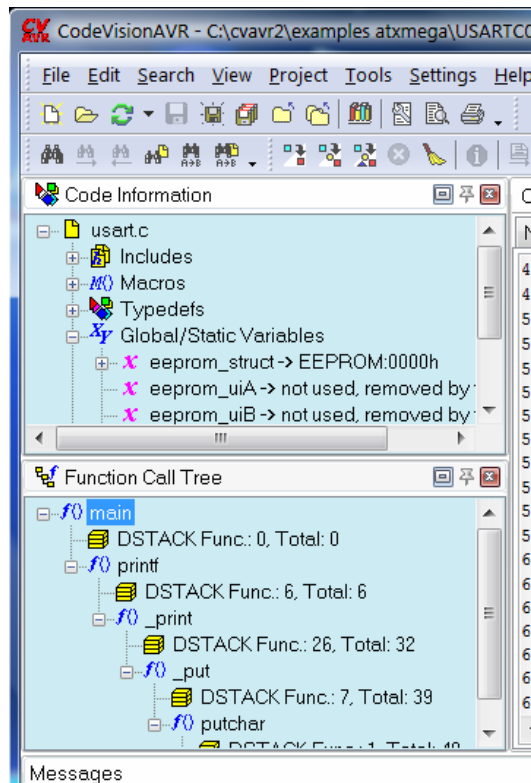
When two workspace windows are docked to the same site one above the other, like in the picture below:



clicking on the window's  icon will maximize the window:

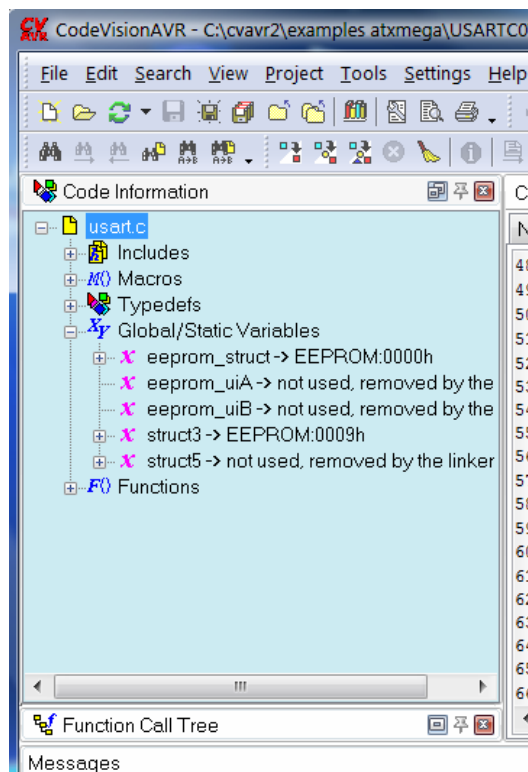

Clicking on the  icon will normalize the window's size.

CodeVisionAVR

The menu toolbars can be placed to any position, by clicking with the left mouse button on the handle and dragging it, while keeping the button pressed.

If the toolbar is moved outside the menu, it will become floating, like in the following picture:

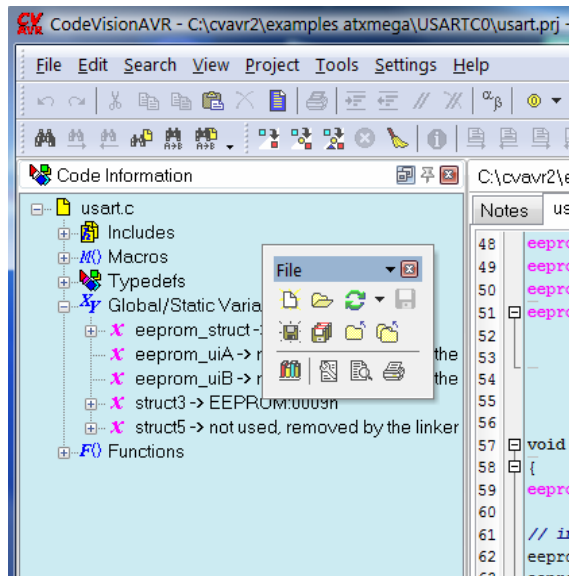

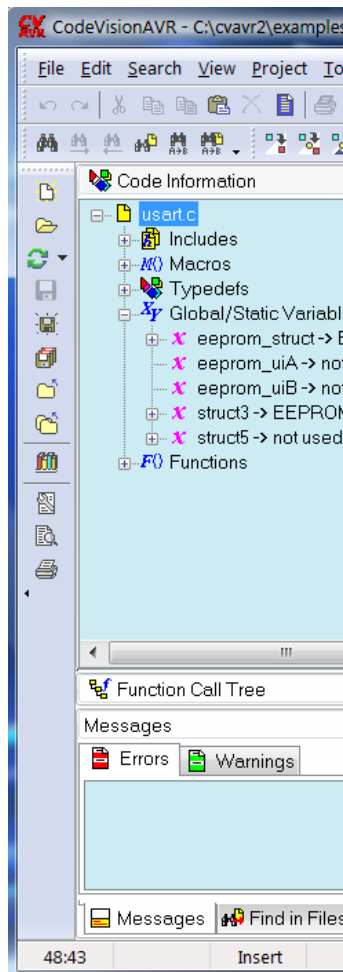

and can be placed anywhere on the desktop.

A toolbar can be also docked anywhere in the application's main window:



CodeVisionAVR

An undocked toolbar can be hidden by clicking on its  icon. Alternatively the toolbars' visible state can be changed by using the **View|Toolbars** menu. The buttons on a toolbar can be individually enabled or disabled by left clicking with the mouse on the  button.

A drop-down menu will open for this purpose:

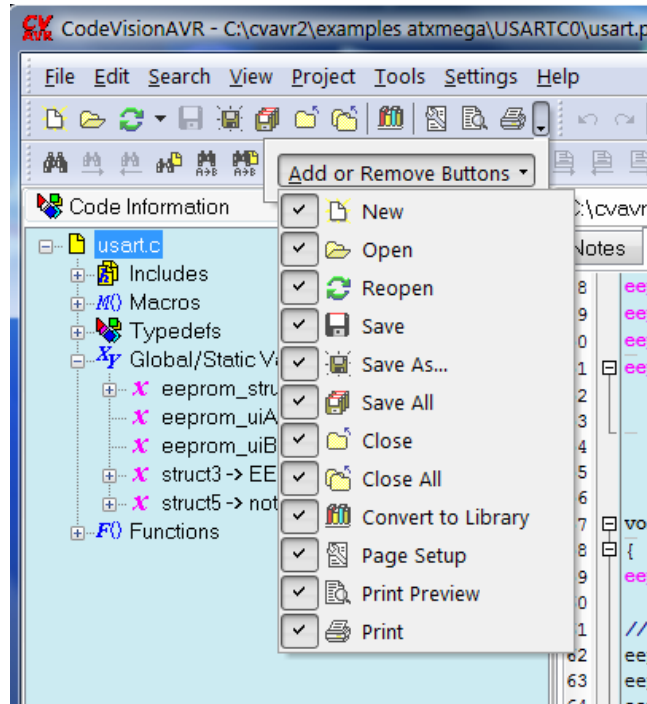

The visibility state of the toolbars can be also individually modified by right clicking with the mouse on the  button.

A drop-down menu will open for this purpose:

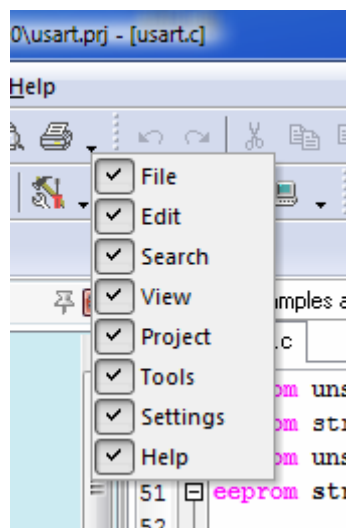

All the workspace layout will be automatically saved at program exit and restored back on the next launch.

CodeVisionAVR

The Editor uses a tabbed multiple window interface.
The following key shortcuts are available:

- Ctrl+TAB - switch to the next editor tabbed window
- Ctrl+Shift+TAB - switch to the previous editor tabbed window
- Ctrl+F4 - close the current editor tabbed window.

The current editor tabbed window can be also closed by clicking on the  icon located on the top right of the tabbed control.

2.2 Working with Files

Using the CodeVisionAVR IDE you can view and edit any text file used or produced by the C compiler or assembler.

2.2.1 Creating a New File

You can create a new source file using the **File|New** menu command, by pressing the **Ctrl+N** keys or the  button on the toolbar.

A dialog box appears, in which you must select **File Type|Source** and press the **Ok** button.

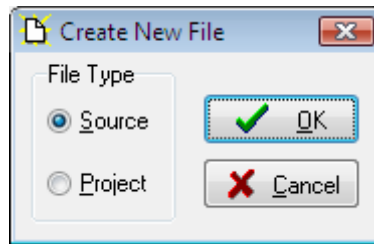

A new editor window appears for the newly created file.

The new file has the name **untitled.c**. You can save this file under a new name using the **File|Save As** menu command or the  toolbar button.

CodeVisionAVR

2.2.2 Opening an Existing File

You can open an existing file using the **File|Open** menu command, by pressing the **Ctrl+O** keys or the  button on the toolbar.

An **Open** dialog window appears.

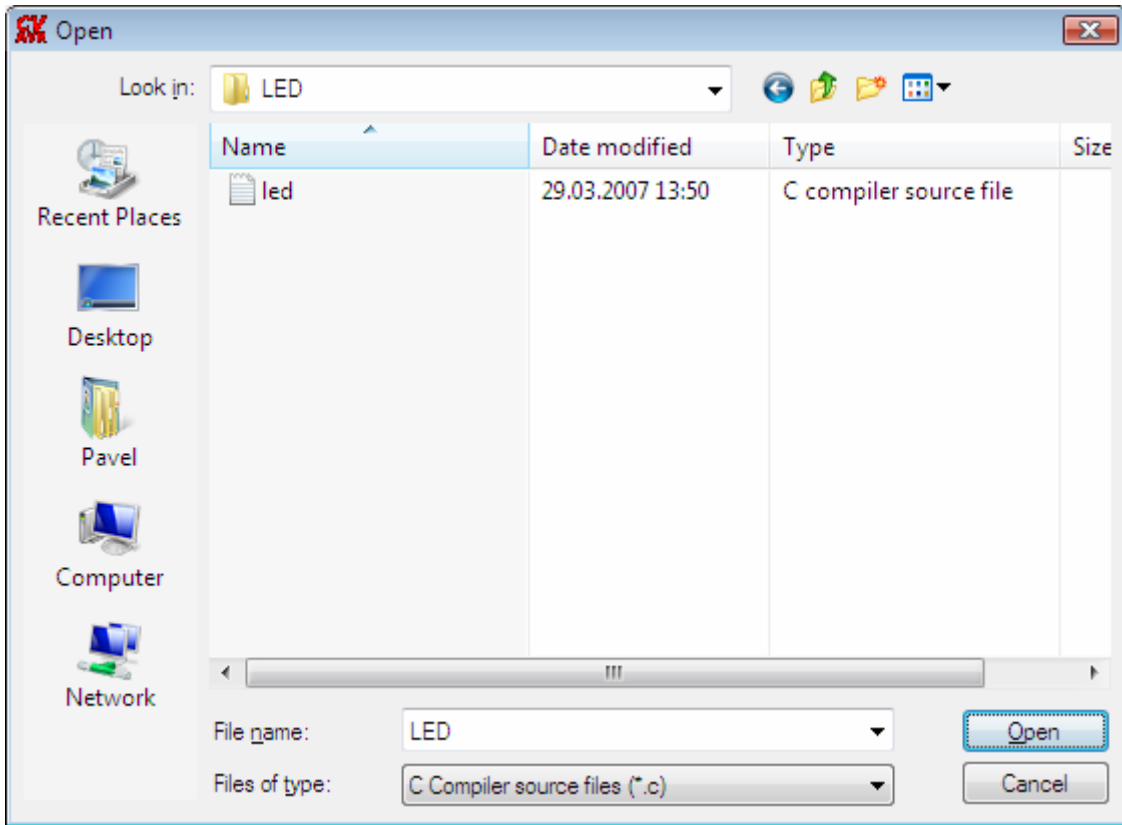

You must select the name and type of file you wish to open.
By pressing the **Open** button you will open the file in a new editor window.

2.2.3 Files History

The CodeVisionAVR IDE keeps a history of the opened files.
The most recent eight files that were used can be reopened using the **File|Reopen** menu command or the  toolbar button.

2.2.4 Editing a File

A previously opened or a newly created file can be edited in the editor window by using the **Tab**, **Arrows**, **Backspace** and **Delete** keys.

Pressing the **Home** key moves the cursor to the start of the current text line.

Pressing the **End** key moves the cursor to the end of the current text line.

Pressing the **Ctrl+Home** keys moves the cursor to the start of the file.

Pressing the **Ctrl+End** keys moves the cursor to the end of the file.

Portions of text can be selected by dragging with the mouse.

You can copy the selected text to the clipboard by using the **Edit|Copy** menu command, by pressing the **Ctrl+C** keys or by pressing the  button on the toolbar.

By using the **Edit|Cut** menu command, by pressing the **Ctrl+X** keys or by pressing the  button on the toolbar, you can copy the selected text to the clipboard and then delete it from the file.



Text previously saved in the clipboard can be placed at the current cursor position by using the **Edit|Paste** menu command, by pressing the **Ctrl+V** keys or pressing the  button on the toolbar.

Clicking in the left margin of the editor window allows selection of a whole line of text.

Selected text can be deleted using the **Edit|Delete** menu command, by pressing the **Ctrl+Delete** keys or the  toolbar button.



Dragging and dropping with the mouse can move portions of text.

Pressing the **Ctrl+Y** keys deletes the text line where the cursor is currently positioned.



Changes in the edited text can be undone, respectively redone, by using the **Edit|Undo**, respectively **Edit|Redo**, menu commands, by pressing the **Ctrl+Z**, respectively **Shift+Ctrl+Z** keys, or by pressing the , respectively  buttons on the toolbar.



Clicking with the mouse right button in the Editor window, opens a pop-up menu that gives access to the above mentioned functions.

2.2.4.1 Searching/Replacing Text

You can find, respectively replace, portions of text in the edited file by using the **Search|Find**, respectively **Search|Replace**, menu commands, by pressing the **Ctrl+F**, respectively **Ctrl+R** keys, or by pressing the , respectively  buttons on the toolbar.

The **Search|Find Next**, respectively **Search|Find Previous**, functions can be used to find the next, respectively previous, occurrences of the search text.

The same can be achieved using the **F3**, respectively **Ctrl+F3** keys or the , respectively the , toolbar buttons.

Searching, respectively replacing, portions of text in files can be performed using the **Search|Find in Files**, respectively **Search|Replace in Files**, menu commands, by pressing the **Ctrl+Shift+F**, respectively **Ctrl+Shift+H** keys, or by pressing the , respectively  buttons on the toolbar.

These functions are also available in the pop-up menu, invoked by mouse right clicking in the Editor window.

2.2.4.2 Setting Bookmarks



Bookmarks can be inserted or removed, at the line where the cursor is positioned, by using the **Edit|Toggle Bookmark** menu command, by pressing the **Shift+Ctrl+0...9** keys or the  toolbar button.

The **Edit|Jump to Bookmark** menu command, the **Ctrl+0...9** keys or the  toolbar button will position the cursor at the start of the corresponding bookmarked text line.

Jumping to the next bookmark can be achieved by using the **Edit|Jump to Next Bookmark** menu command, by pressing the **F2** key or by using the  toolbar button.

Jumping to the previous bookmark can be achieved by using the **Edit|Jump to Previous Bookmark** menu command, by pressing the **Shift+F2** keys or by using the  toolbar button.

After a jump to a bookmark was performed, the **Edit|Go Back** menu command or the  toolbar button allow to return to the previous position in the file.



The **Edit|Go Forward** menu command or the  toolbar button allow to return to the file position before the **Edit|Go Back** menu command or the  toolbar button were used.

These functions are also available in the pop-up menu, invoked by mouse right clicking in the Editor window.

2.2.4.3 Jumping to a Symbol Definition or Declaration

When the editor cursor is located on a symbol name and the **Edit|Go to Definition/Declaration** menu command is performed, the **F12** key or the  toolbar button are pressed, a jump will be performed to the symbol definition or declaration located in any of the project's source files.

After a jump to the definition or declaration was performed, the **Edit|Go Back** menu command or the  toolbar button allow to return to the previous position in the edited file.



The **Edit|Go Forward** menu command or the  toolbar button allow to return to the file position before the **Edit|Go Back** menu command or the  toolbar button were used.

These functions are also available in the pop-up menu, invoked by mouse right clicking in the Editor window.

2.2.4.4 Jumping to a Specific Line Number in the Edited File

You can go to a specific line number in the edited file, by using the **Edit|Go to Line** menu command, by pressing the **Ctrl+G** keys or the  toolbar button.

After a jump to a specific line was performed, the **Edit|Go Back** menu command or the  toolbar button allow to return to the previous position in the edited file.

The **Edit|Go Forward** menu command or the  toolbar button allow to return to the file position before the **Edit|Go Back** menu command or the  toolbar button were used.

These functions are also available in the pop-up menu, invoked by mouse right clicking in the Editor window.

2.2.4.5 Printing a Text Selection



Portions of text can be selected by dragging with the mouse.

The **Edit|Print Selection** menu command or the  toolbar button allows the printing of the selected text.

This function is also available in the pop-up menu, invoked by mouse right clicking in the Editor window.

2.2.4.6 Indenting/Unindenting a Text Selection



Portions of text can be selected by dragging with the mouse.

Selected portions of text can be indented, respectively unindented, using the **Edit|Indent Selection**, respectively **Edit|Unindent Selection**, menu commands, by pressing the **Ctrl+I**, respectively **Ctrl+U** keys or the  , respectively  , toolbar buttons.

These functions are also available in the pop-up menu, invoked by mouse right clicking in the Editor window.

2.2.4.7 Commenting/Uncommenting a Text Selection

Portions of text can be selected by dragging with the mouse.

Selected portions of text can be commented, respectively uncommented, using the **Edit|Comment Selection**, respectively **Edit|Unindent Selection**, menu commands, by pressing the **Ctrl+/,** respectively **Ctrl+]** keys or the  , respectively  , toolbar buttons.

These functions are also available in the pop-up menu, invoked by mouse right clicking in the Editor window.

2.2.4.8 Match Braces

If the cursor is positioned before an opening, respectively after a closing, brace then selecting the **Edit|Match Braces** menu command, pressing the **Ctrl+M** keys or the  toolbar button will position the cursor after, respectively before, the corresponding matching closing, respectively opening brace. This function is also available in the pop-up menu, invoked by mouse right clicking in the Editor window.

2.2.4.9 Inserting Special Characters in the Text

Special characters can be inserted in the edited text, at the cursor is position, by using the **Edit|Insert Special Characters** menu command, by pressing the **Ctrl+.** keys or the  toolbar button.

A pop-up window containing a character map grid will be displayed, allowing the user to select the appropriate character to be inserted:

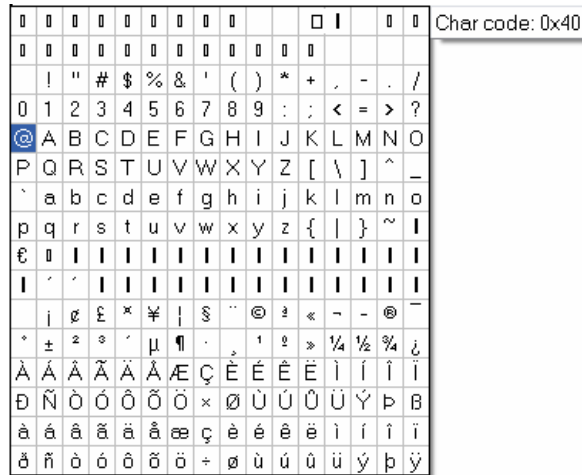

This function is also available in the pop-up menu, invoked by mouse right clicking in the Editor window.

2.2.4.10 Using the Auto Complete Functions

The CodeVisionAVR Editor has the possibility to display pop-up hint windows for function parameters and structure or union members.

These functions can be enabled and configured using the **Settings|Editor|Auto Complete** menu.

Function parameter auto complete is automatically invoked when the user types the name of a function defined in the currently edited file, followed by a '(' auto completion triggering character. A pop-up hint with parameter list will show like in the example below:



The parameter to be specified is highlighted with bold text.

Structure or union members auto complete is invoked after the user writes the name of a structure/union or pointer to structure/union followed by the '.' or '->' auto completion triggering characters.

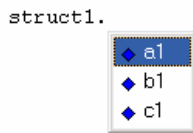

A pop-up hint with the members list will show like in the example below:



The user can select the member to be inserted in the text at the cursor position, by using the arrow keys, respectively the mouse, and then pressing Enter, respectively the left mouse button. The structure or union members auto completion works only for global structures/unions defined in the currently edited source file and after a **Project|Compile** or **Project|Build** was performed.

2.2.4.11 Using Code Folding

The CodeVisionAVR Editor has the possibility of displaying staples on the left side of code blocks delimited by the { } characters.

For each code block there will be also displayed collapse  or expansion  marks on the gutter located on the left side of the Editor window. Clicking on these marks allow to individually fold or unfold blocks of code.

The **View|Toggle Fold** menu and the  toolbar button allow to collapse/expand the block of code where the cursor is located.

The **View|Expand All Folds** menu and the  toolbar button allow to expand all folded blocks of code.

The **View|Collapse All Folds** menu and the  toolbar button allow to collapse all blocks of code delimited by the { } characters.

These commands are also available in the pop-up menu that is invoked by right clicking with the mouse in the Editor window.

If the **Settings|Editor|General|Visual Aids|Save Folded Lines** option is enabled, the folded/unfolded state of the code blocks is saved when the file is closed and it will be restored back, when the file is opened again.

CodeVisionAVR

2.2.5 Saving a File

The currently edited file can be saved by using the **File|Save** menu command, by pressing the **Ctrl+S** keys or by pressing the  button on the toolbar.

When saving, the Editor will create a backup file with a ~ character appended to the extension. All currently opened files can be saved using the **File|Save All** menu command, by pressing the **Ctrl+Shift+S** keys or the  toolbar button.

2.2.6 Renaming a File

The currently edited file can be saved under a new name by using the **File|Save As** menu command or the  toolbar button.

A **Save As** dialog window will open.

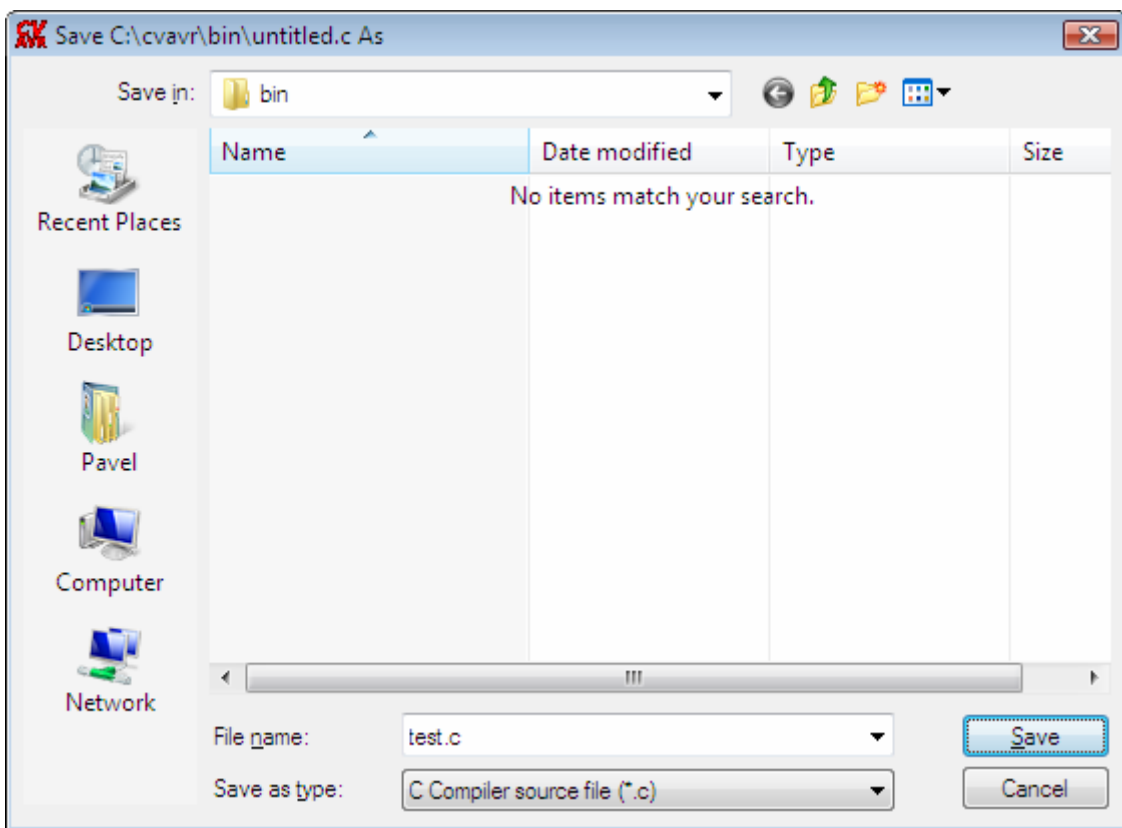

You will have the possibility to specify the new name and type of the file, and eventually its new location.

CodeVisionAVR

2.2.7 Printing a File

You can print the current file using the **File|Print** menu command or by pressing the  button on the toolbar.

The contents of the file will be printed to the Windows default printer.

The paper margins used when printing can be set using the **File|Page Setup** menu command or the  toolbar button, which opens the **Page Setup** dialog window.

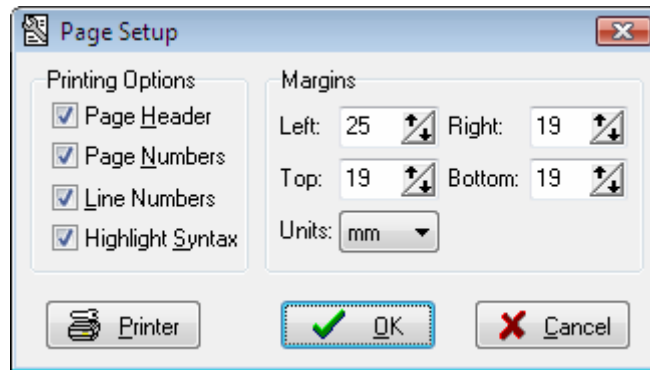

The units used when setting the paper margins are specified using the **Units** list box.

The printer can be configured by pressing the **Printer** button in this dialog window.

Changes can be saved, respectively canceled, using the **OK**, respectively **Cancel** buttons.

The print result can be previewed using the **File|Print Preview** menu command or by pressing the  toolbar button.

2.2.8 Closing a File

You can quit editing the current file by using the **File|Close** menu command, the **Ctrl+F4** shortcut or the  toolbar button.

The current editor tabbed window can be also closed by clicking on the  icon located on the top right of the tabbed control.

If the file was modified, and wasn't saved yet, you will be prompted if you want to do that.

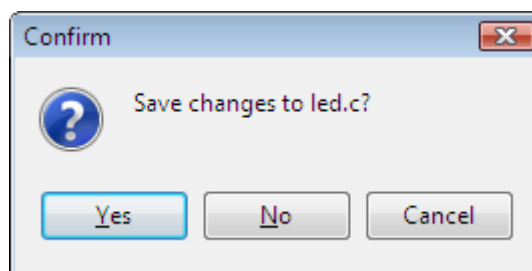

Pressing **Yes** will save changes and close the file.

Pressing **No** will close the file without saving the changes.

Pressing **Cancel** will disable the file closing process.

2.2.9 Closing Multiple Files

Closing several files can be performed using the **File|Close Multiple** menu command or the  toolbar button.

A dialog window, which lists all the opened files, will open for this purpose:

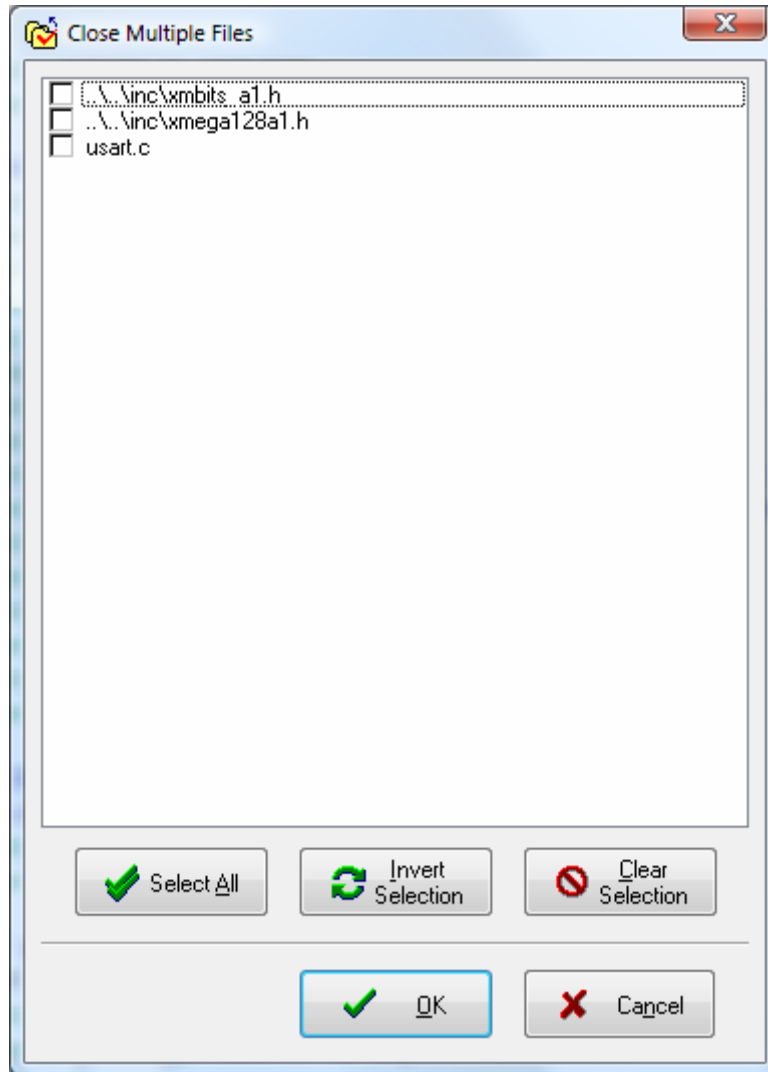

Files to be closed can be selected by checking the appropriate check boxes. All the listed files can be selected using the **Select All** button. The state of the check boxes can be reversed using the **Invert Selection** button. The **Clear Selection** button can be used to un-check all the check boxes.

Pressing the **OK** button will close all the selected files from the list. Pressing the **Cancel** button will close the dialog window, without closing any file.

2.2.10 Using the Code Templates

The **Code Templates** window allows easy adding most often used code sequences to the currently edited file.

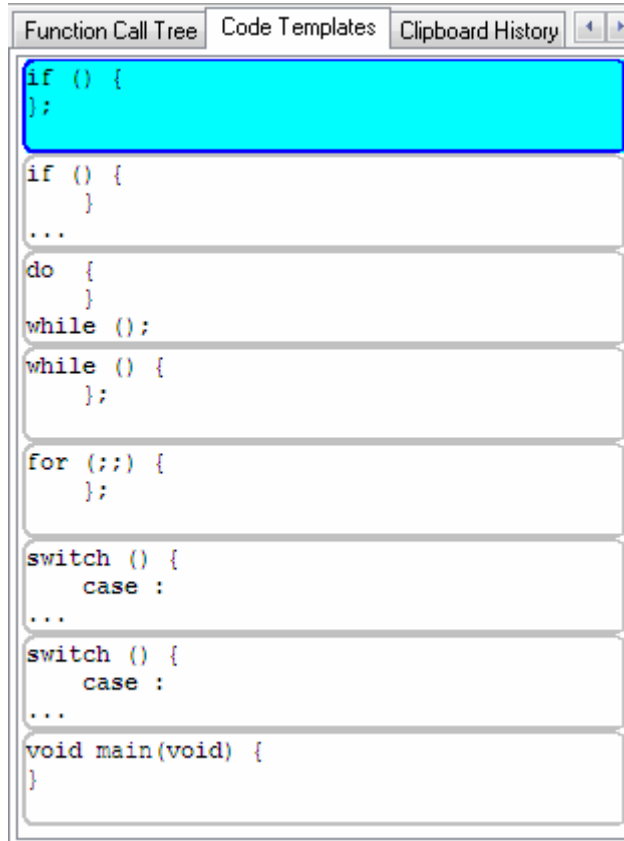

This is achieved by clicking on the desired code sequence in the **Code Templates** window and then dragging and dropping it to the appropriate position in the Editor window.

New code templates can be added to the list by dragging and dropping a text selection from the Editor window to the **Code Templates** window.

By right clicking in the **Code Templates** window you can open a pop-up menu with the following choices:

- **Copy to the Edit Window** the currently selected code template
- **Paste** a text fragment from the clipboard to the **Code Templates** window
- **Move Up** in the list the currently selected code template
- **Move Down** in the list the currently selected code template
- **Delete** the currently selected code template from the list.

2.2.11 Using the Clipboard History

The **Clipboard History** window allows viewing and accessing text fragments that were recently copied to the clipboard.

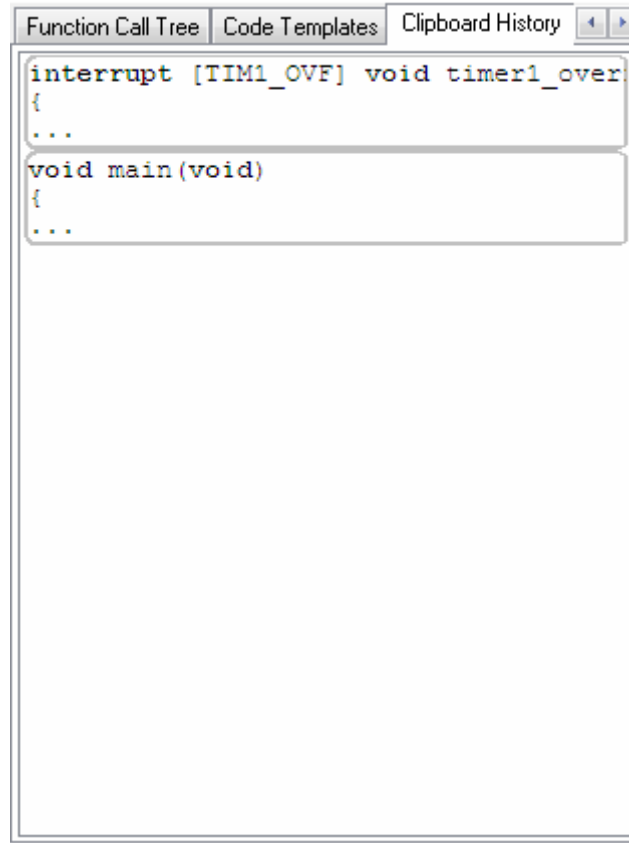

By right clicking in the **Clipboard History** window you can open a pop-up menu with the following choices:

- **Copy to the Edit Window** the currently selected text fragment from the **Clipboard History** window
- **Delete** the currently selected text fragment from the list
- **Delete All** the text fragments from the list.

2.3 Working with Projects

The Project groups the source file(s) and compiler settings that you use for building a particular program.

2.3.1 Creating a New Project

You can create a new Project using the **File|New** menu command or by pressing the  button on the toolbar.

A dialog box appears, in which you must select **File Type|Project** and press the **OK** button.

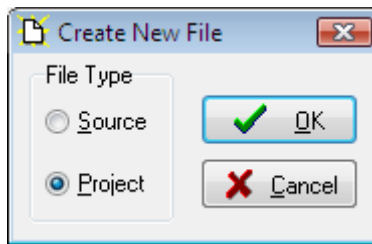

A dialog will open asking you to confirm if you would like to use the CodeWizardAVR to create the new project.

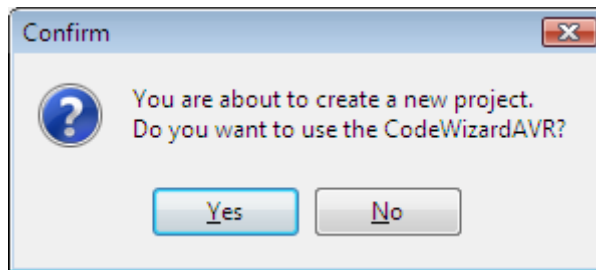

If you select **No** then the **Create New Project** dialog window will open.

CodeVisionAVR

You must specify the new Project file name and its location.

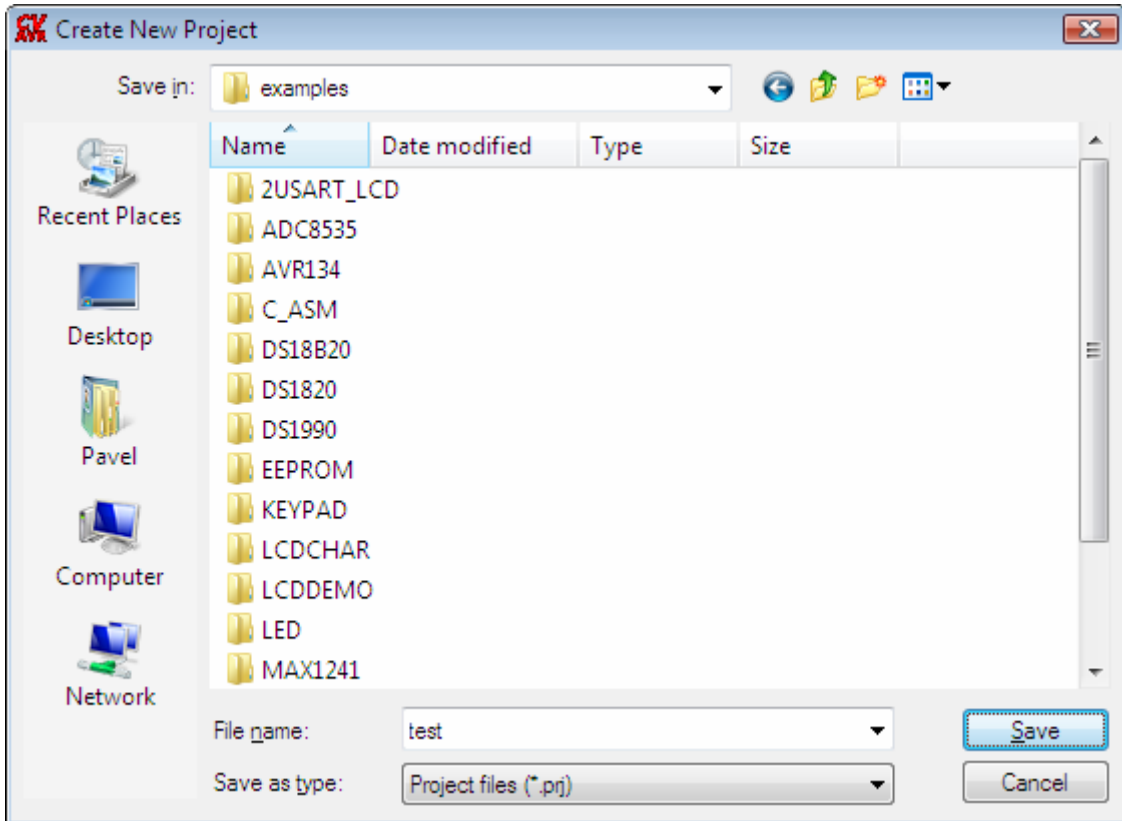

The Project file will have the .prj extension.

You can configure the Project by using the **Project|Configure** menu command or by pressing the  toolbar button.

CodeVisionAVR

2.3.2 Opening an Existing Project

You can open an existing Project file using the **File|Open** menu command or by pressing the  button on the toolbar.

An **Open** dialog window appears.

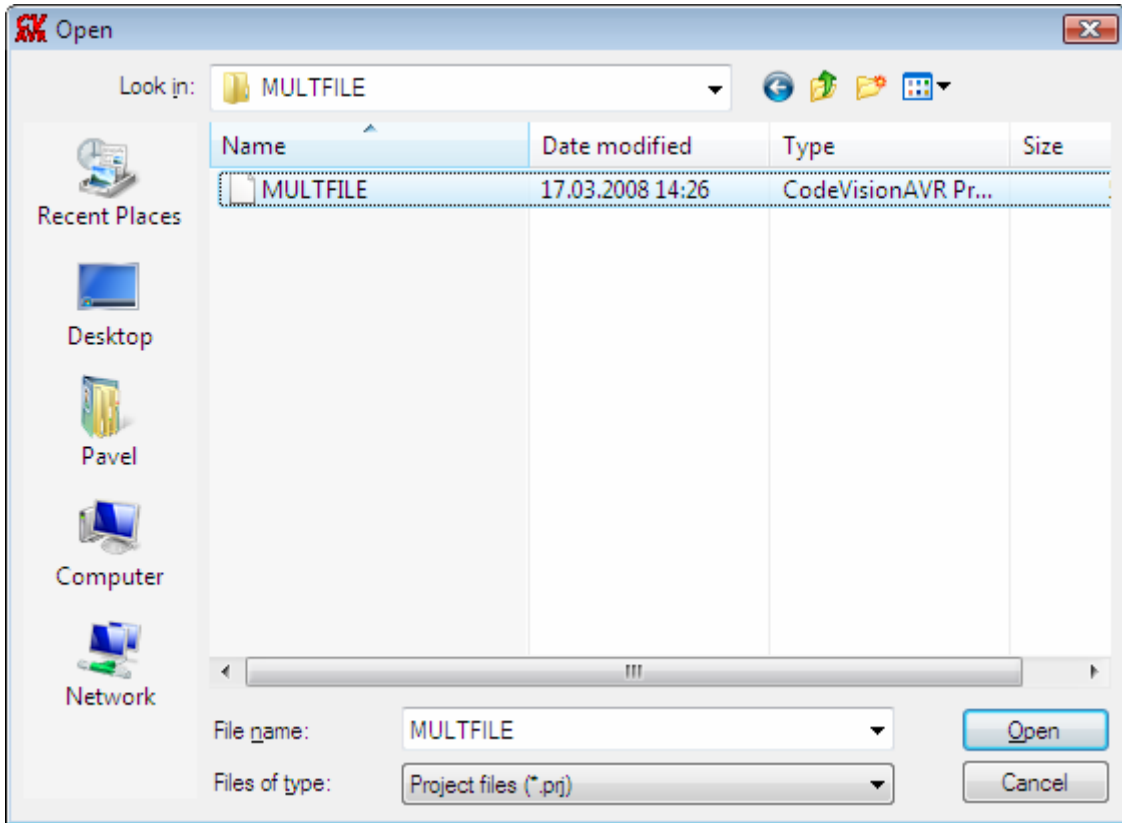

You must select the file name of the Project you wish to open.

By pressing the **Open** button you will open the Project file and its source file(s).

You can later configure the Project by using the **Project|Configure** menu command or by pressing the  toolbar button.

2.3.3 Adding Notes or Comments to the Project

With every Project the CodeVisionAVR IDE creates an associated text file where you can place notes and comments.

You can access this file using the **Project|Notes** or **Windows** menu commands.

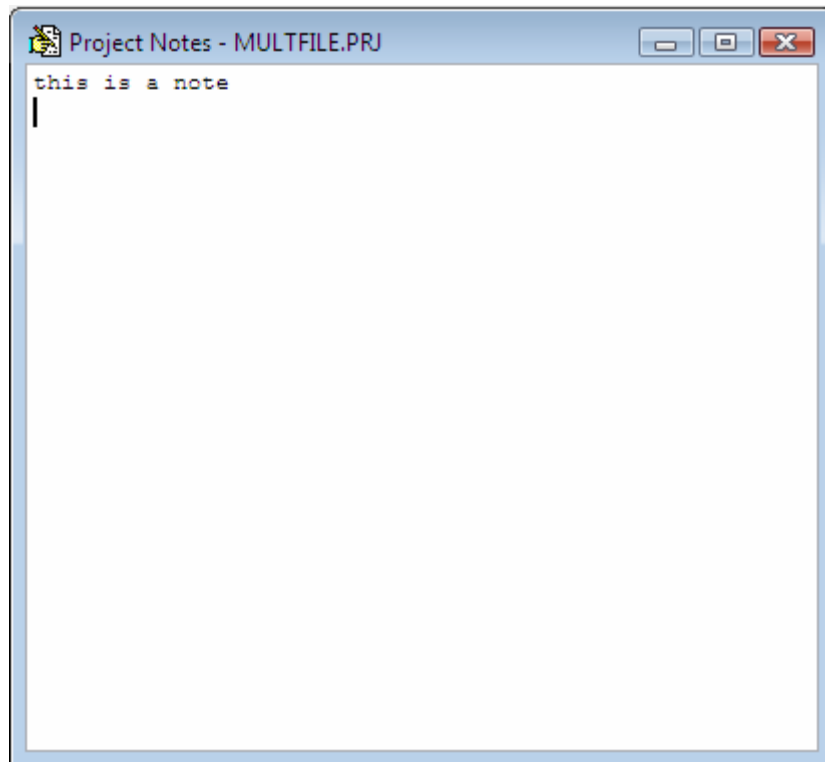

This file can be edited using the standard Editor commands.

The file is automatically saved when you **Close** the Project or **Quit** the CodeVisionAVR program.

CodeVisionAVR

2.3.4 Configuring the Project

The Project can be configured using the **Project|Configure** menu command or the  toolbar button.

2.3.4.1 Adding or Removing a File from the Project

To add or remove a file from the currently opened project you must use the **Project|Configure** menu command or the  toolbar button.

A **Configure Project** tabbed dialog window will open.
You must select the **Files** and **Input Files** tabs.

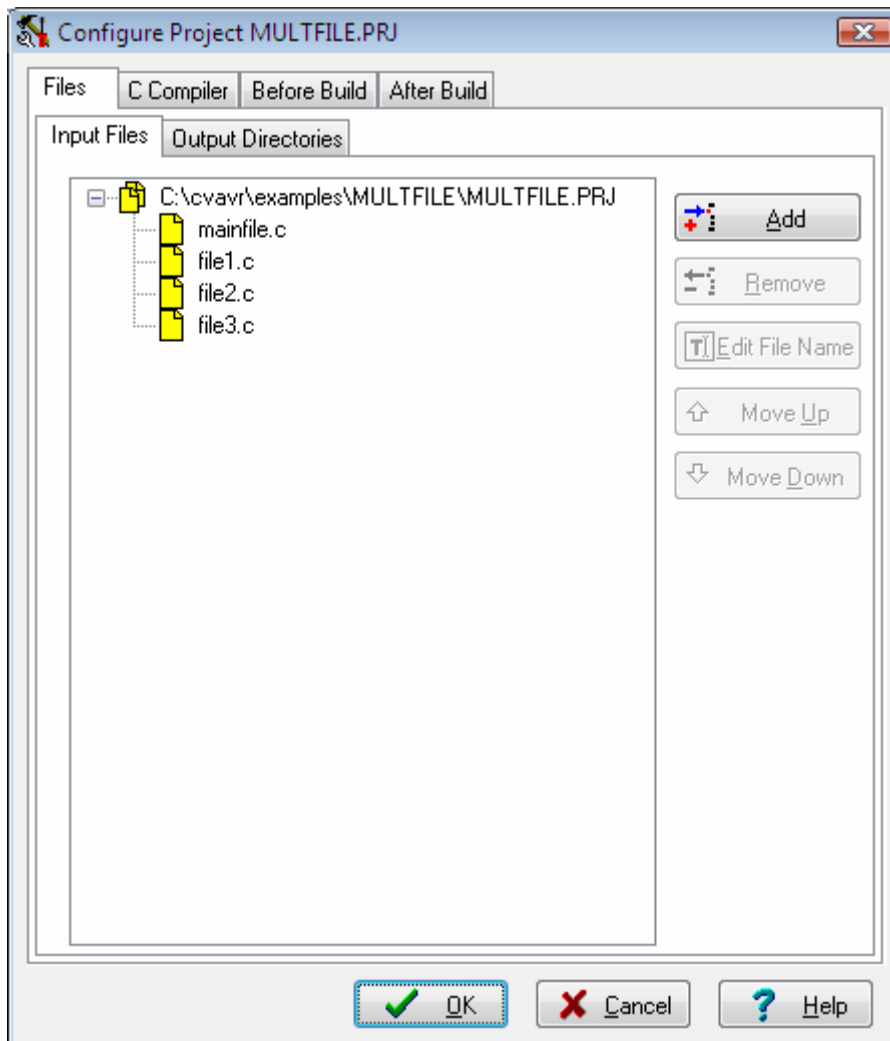

By pressing the **Add** button you can add a source file to the project.

CodeVisionAVR

Multiple files can be added by holding the Ctrl key when selecting in the **Add File to Project** dialog.

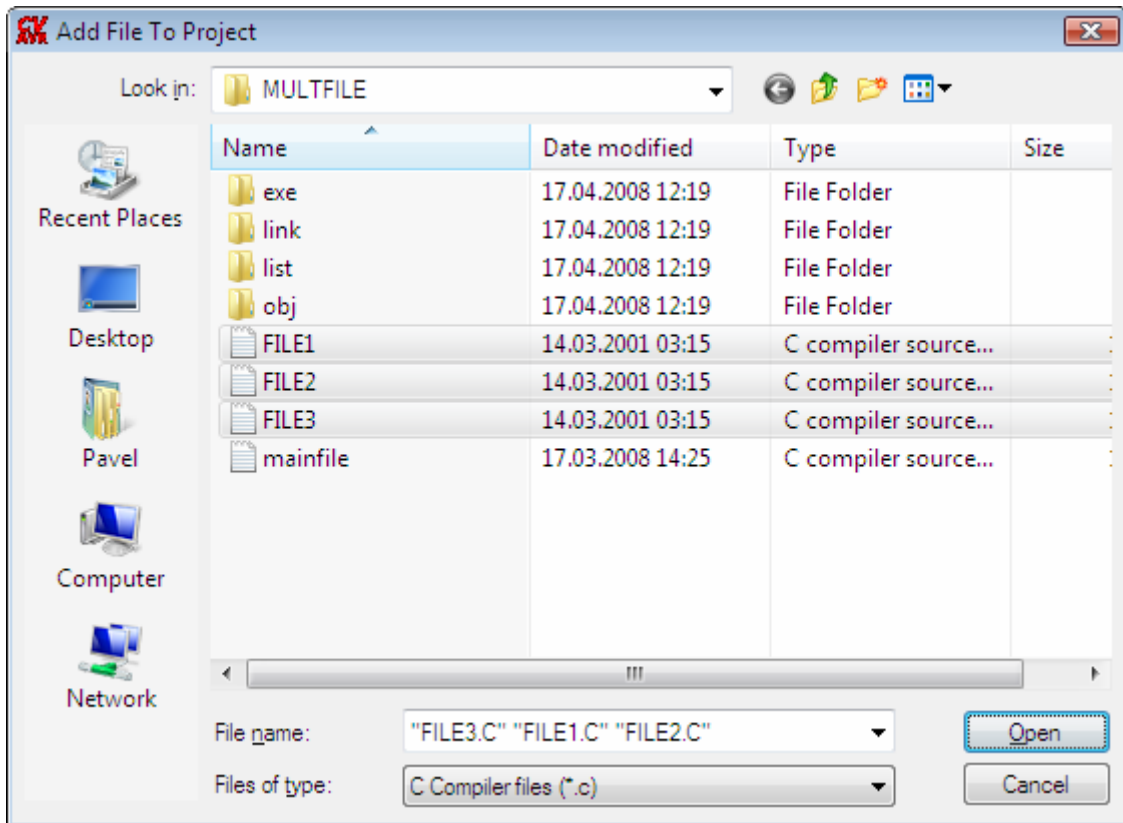

When the project is **Open**-ed all project files will be opened in the editor.

By clicking on a file, and then pressing the **Remove** button, you will remove this file from the project.

The project's file compilation order can be changed by clicking on a file and moving it up, respectively down, using the **Move Up**, respectively **Move Down**, buttons.

Changes can be saved, respectively canceled, using the **OK**, respectively **Cancel** buttons.

When creating a project with multiple files the following rules must be preserved:

- only .C files must be added to the project's Files list
- there's no need to #include the .C files from the Files list as they will be automatically linked
- data type definitions and function declarations must be placed in header .H files, that will be #include -ed as necessary in the .C files
- global variables declarations must be placed in the .C files where necessary
- there's no need to declare global variables, that are not static, in header .H files, because if these files will be #include -ed more than once, the compiler will issue errors about variable redeclarations.

2.3.4.2 Setting the Project Output Directories

Selecting the **Output Directories** tab allows the user to specify distinct directories where will be placed the files resulted after the compilation and linking.

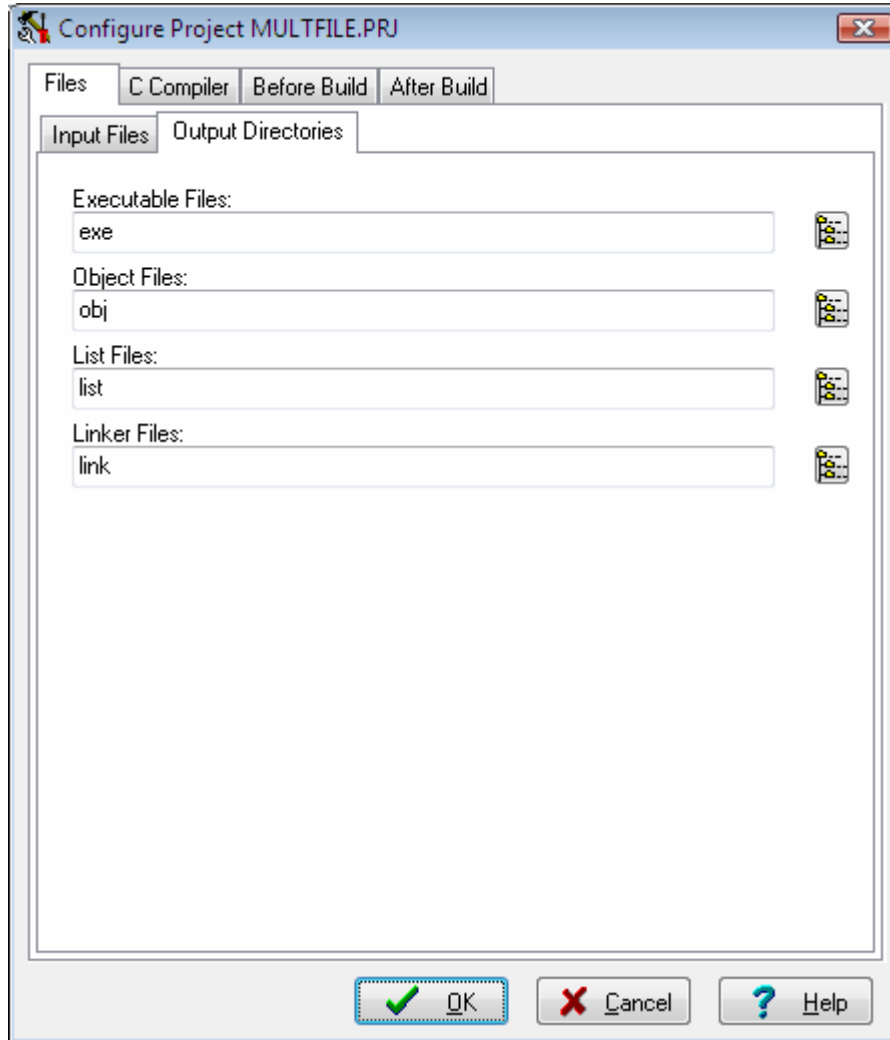

Pressing the  button allows to select an existing directory.

The .rom and .hex files resulted after the **Build** process will be placed in the **Executable Files** directory.

The object files resulted after the **Compile** process will be placed in the **Object Files** directory. The COFF object file that results after the **Build** process will be also placed in the **Object Files** directory.

The .asm, .lst and .map files created during the **Build** process will be placed in the **List Files** directory.

Various files created by the linker during the **Build** process will be placed in the **Linker Files** directory.

CodeVisionAVR

2.3.4.3 Setting the C Compiler Options

To set the C compiler options for the currently opened project you must use the **Project|Configure** menu command or the  toolbar button.

A **Configure Project** tabbed dialog window will open. You must select the **C Compiler** and **Code Generation** tabs.

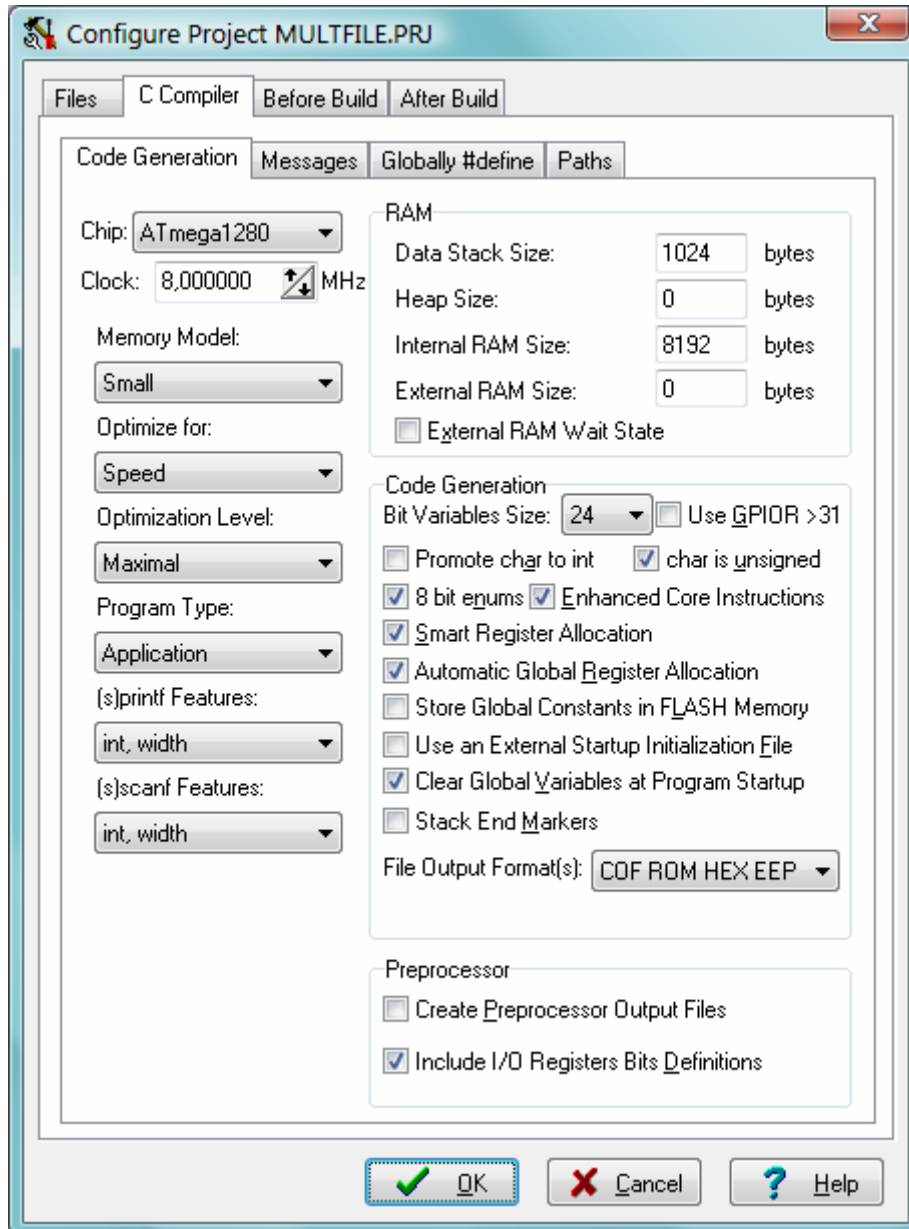

You can select the target AVR microcontroller chip by using the **Chip** combo box. You must also specify the CPU **Clock** frequency in MHz, which is needed by the Delay Functions, 1 Wire Protocol Functions and Maxim/Dallas Semiconductor DS1820/DS18S20/DS18B20 Temperature Sensors Functions.

The required memory model can be selected by using the **Memory Model** list box.

CodeVisionAVR

The compiled program can be optimized for minimum size, respectively maximum execution speed, using the **Optimize for|Size**, respectively **Optimize for|Speed**, settings.

The amount of code optimization can be specified using the **Optimization Level** setting. The *Maximal* optimization level may make difficult the code debugging with AVR Studio.

For devices that allow self-programming the **Program Type** can be selected as:

- **Application**
- **Boot Loader**

If the **Boot Loader** program type was selected, a supplementary **Boot Loader Debugging in AVR Studio** option is available.

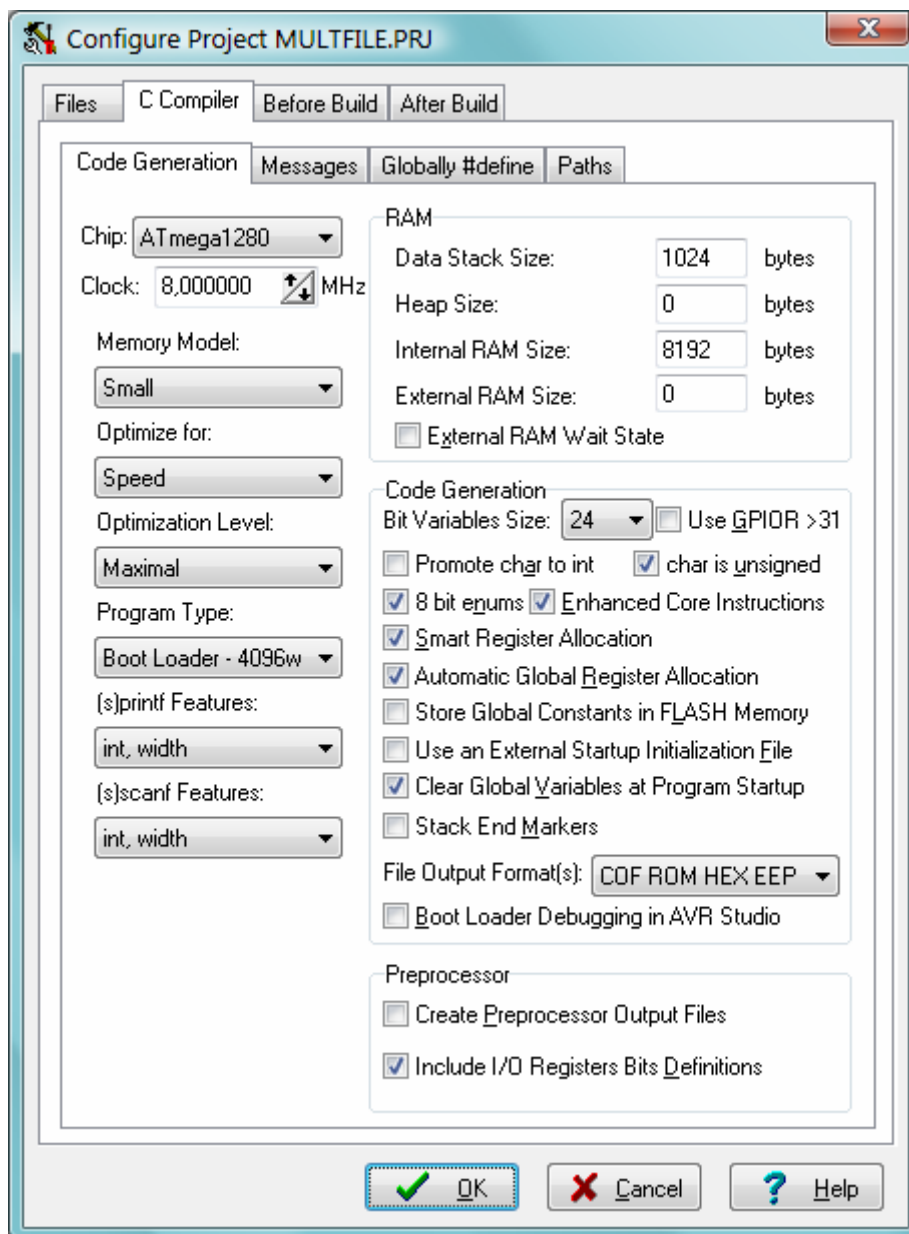

If this option is enabled, the compiler will generate supplementary code that allows the Boot Loader to be source level debugged in the AVR Studio simulator/emulator.

When programming the chip with the final Boot Loader code, the Boot Loader Debugging option must be disabled.

CodeVisionAVR

For reduced core chips like ATtiny10, there is an additional option: **Enable auto Var. Watch in AVR Studio**.

If this option is enabled, the compiler will generate additional code that allows local automatic variables, saved in the Data Stack, to be watched in AVR Studio 4.15 or later.

After finishing debugging the program, this option should be disabled and the project rebuilt.

This will allow to reduce the size of the program and increase its execution speed.

The **(s)printf features** option allows to select which versions of the printf and sprintf **Standard C Input/Output Functions** will be linked in your project:

- **int** - the following conversion type characters are supported: 'c', 's', 'p', 'i', 'd', 'u', 'x', 'X', '%', no width or precision specifiers are supported, only the '+' and '-' flags are supported, no input size modifiers are supported
- **int, width** - the following conversion type characters are supported: 'c', 's', 'p', 'i', 'd', 'u', 'x', 'X', '%', the width specifier is supported, the precision specifier is not supported, only the '+', '-', '0' and '-' flags are supported, no input size modifiers are supported
- **long, width** - the following conversion type characters are supported: 'c', 's', 'p', 'i', 'd', 'u', 'x', 'X', '%', the width specifier is supported, the precision specifier is not supported, only the '+', '-', '0' and '-' flags are supported, only the 'l' input size modifier is supported
- **long, width, precision** - the following conversion type characters are supported: 'c', 's', 'p', 'i', 'd', 'u', 'x', 'X', '%', the width and precision specifiers are supported, only the '+', '-', '0' and '-' flags are supported, only the 'l' input size modifier is supported
- **float, width, precision** - the following conversion type characters are supported: 'c', 's', 'p', 'i', 'd', 'u', 'e', 'E', 'f', 'x', 'X', '%', the width and precision specifiers are supported, only the '+', '-', '0' and '-' flags are supported, only the 'l' input size modifier is supported.

The more features are selected, the larger is the code size generated for the printf and sprintf functions.

The **(s)scanf features** option allows to select which versions of the scanf and sscanf **Standard C Input/Output Functions** will be linked in your project:

- **int, width** - the following conversion type characters are supported: 'c', 's', 'i', 'd', 'u', 'x', '%', the width specifier is supported, no input size modifiers are supported
- **long, width** - the following conversion type characters are supported: 'c', 's', 'i', 'd', 'u', 'x', '%', the width specifier is supported, only the 'l' input size modifier is supported.

The more features are selected, the larger is the code size generated for the scanf and sscanf functions.

The **Data Stack Size** must be also specified.

If the dynamic memory allocation functions from the Standard Library are to be used, the **Heap Size** must be also specified.

It can be calculated using the following formulae:

$$heap_size = (n + 1) \cdot 4 + \sum_{i=1}^n block_size_i$$

where: n is the number of memory blocks that will be allocated in the heap

$block_size_i$ is the size of the memory block i

If the memory allocation functions will not be used, then the **Heap Size** must be specified as zero.

Eventually you may also specify the **External RAM Size** (in case the microcontroller have external SRAM memory connected).

CodeVisionAVR

The **External RAM Wait State** option enables the insertion of wait states during access to the external RAM. This is useful when using slow memory devices.

If an Atmel AT94K05, AT94K10, AT94K20 or AT94K40 FPSLIC device will be used, than there will be the possibility to specify the **Program RAM Size** in Kwords.

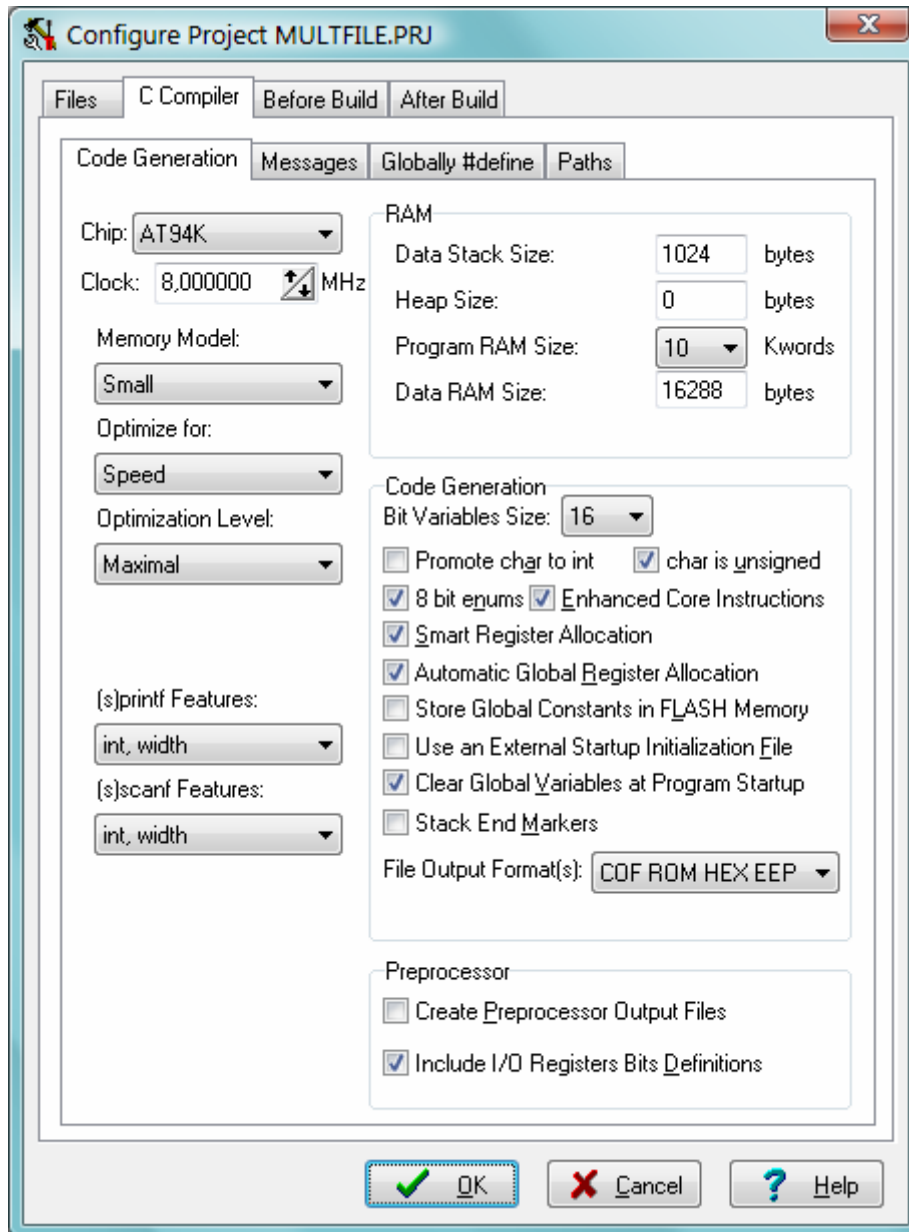

The maximum size of the global bit variables, which are placed in the GPIOR (if present) and registers R2 to R14, can be specified using the **Bit Variables Size** list box.

The **Use GPIOR >31** option, when checked, allows using GPIOR located at addresses above 31 for global bit variables.

Note that bit variables located in GPIOR above address 31 are accessed using the IN, OUT, OR, AND instructions, which leads to larger and slower code than for bit variables located in GPIOR with the address range 0...31, which use the SBI, CBI instructions. Also the access to bit variables located in GPIOR above address 31 is not atomic.

Therefore it is recommended to leave the **Use GPIOR >31** option not checked if the number of global bit variables is small enough and no additional registers are needed for their storage.

CodeVisionAVR

Checking the **Promote char to int** check box enables the ANSI promotion of **char** operands to **int**. This option can also be specified using the **#pragma promotechar** compiler directive. Promoting **char** to **int** leads to increases code size and lowers speed for an 8 bit chip microcontroller like the AVR.

In order to assure code compatibility with other C compilers, the **Promote char to int** option is enabled by default for newly created projects.

If the **char is unsigned** check box is checked, the compiler treats by default the **char** data type as an unsigned 8 bit in the range 0...255.

If the check box is not checked the **char** data type is by default a signed 8 bit in the range -128...127. This option can also be specified using the **#pragma uchar** compiler directive.

Treating **char** as unsigned leads to better code size and speed.

If the **8 bit enums** check box is checked, the compiler treats the enumerations as being of 8 bit **char** data type, leading to improved code size and execution speed of the compiled program. If the check box is not checked the enumerations are considered as 16 bit **int** data type as required by ANSI.

The **Enhanced Instructions** check box allows enabling or disabling the generation of Enhanced Core instructions for the new ATmega and AT94K FPSLIC devices.

The **Smart Register Allocation** check box enables allocation of registers R2 to R14 (not used for bit variables) and R16 to R21 in such a way that 16bit variables will be preferably located in even register pairs, thus favouring the usage of the enhanced core MOVW instruction for their access. This option is effective only if the **Enhanced Instructions** check box is also checked.

If **Smart Register Allocation** is not enabled, the registers will be allocated in the order of variable declaration.

The **Smart Register Allocation** option should be disabled if the program was developed using CodeVisionAVR prior to V1.25.3 and it contains inline assembly code that accesses the variables located in registers R2 to R14 and R16 to R21.

The registers in the range R2 to R14, not used for bit variables, can be automatically allocated to **char** and **int** global variables and global pointers by checking the **Automatic Global Register Allocation** check box.

If the **Store Global Constants in FLASH Memory** check box is checked, the compiler will treat the **const** type qualifier as equivalent to the **flash** memory attribute and will place the constants in FLASH memory. If the option is not checked, constants marked with the **const** type qualifier will be stored in RAM memory and the ones marked with the **flash** memory attribute will be stored in FLASH memory. The **Store Global Constants in FLASH Memory** option is, by default, not enabled for newly created projects.

In order to maintain compatibility with V1.xx projects, the **Store Global Constants in FLASH Memory** option must be checked.

An external startup.asm file can be used by checking the **Compilation|Use an External Startup File** check box.

The **Clear Global Variables at Program Startup** check box allows enabling or disabling the initialization with zero of global variables located in RAM and registers R2 to R14 at program startup after a chip reset. If an external startup.asm file is used, this option must signal to the compiler if the variable initialization with zero is performed in this file or not.

For debugging purposes you have the option **Stack End Markers**. If you select it, the compiler will place the strings **DSTACKEND**, respectively **HSTACKEND**, at the end of the **Data Stack**, respectively **Hardware Stack** areas.

When you debug the program with the AVR Studio debugger you may see if these strings are overwritten, and consequently modify the **Data Stack Size**.

When your program runs correctly you may disable the placement of the strings in order to reduce code size.

CodeVisionAVR

Using the **File Output Format(s)** list box you can select the following formats for the files generated by the compiler:

- COFF (required by the Atmel AVR Studio debugger), ROM, Intel HEX and EEP (required by the In-System Programmer) ;
- Atmel generic OBJ, ROM, Intel HEX and EEP (required by the In-System Programmer).

The following **Preprocessor** options can be set:

- **Create Preprocessor Output Files** - when enabled, an additional file with the .i extension will be created for each compiled source file. The preprocessor output files will contain the source files text with all the preprocessor macros expanded. Enabling this option will slow down the compilation process.
- **Include I/O Registers Bits Definitions** - will enable the I/O register bits definitions in the device header files.

The **Advanced** tab, which is present only in the Advanced and Professional versions of the compiler, enables more detailed custom configuration like the number and jump type of the interrupt vectors and memory usage:

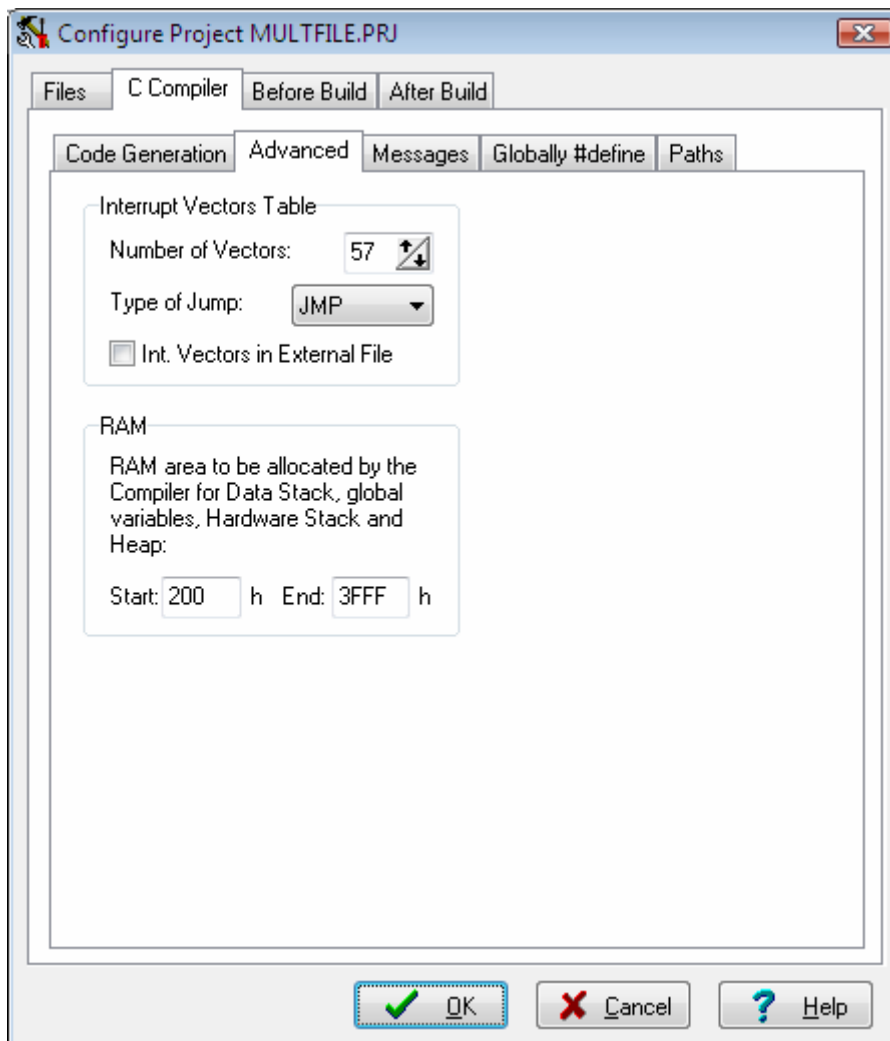

The **Int. Vectors in External File** option enables or disables placing the interrupt vectors in an external vectors.asm file created by the user. If this option is enabled the compiler will not generate any interrupt vectors by itself as the vectors will be present in the vectors.asm file.

CodeVisionAVR

The **Libraries** tab is used for configuring specific driver libraries used by the compiler. The **MMC/SD/SD HC Card** tab is used for configuring the I/O port allocation for the MMC/SD/SD HC FASH memory card driver.

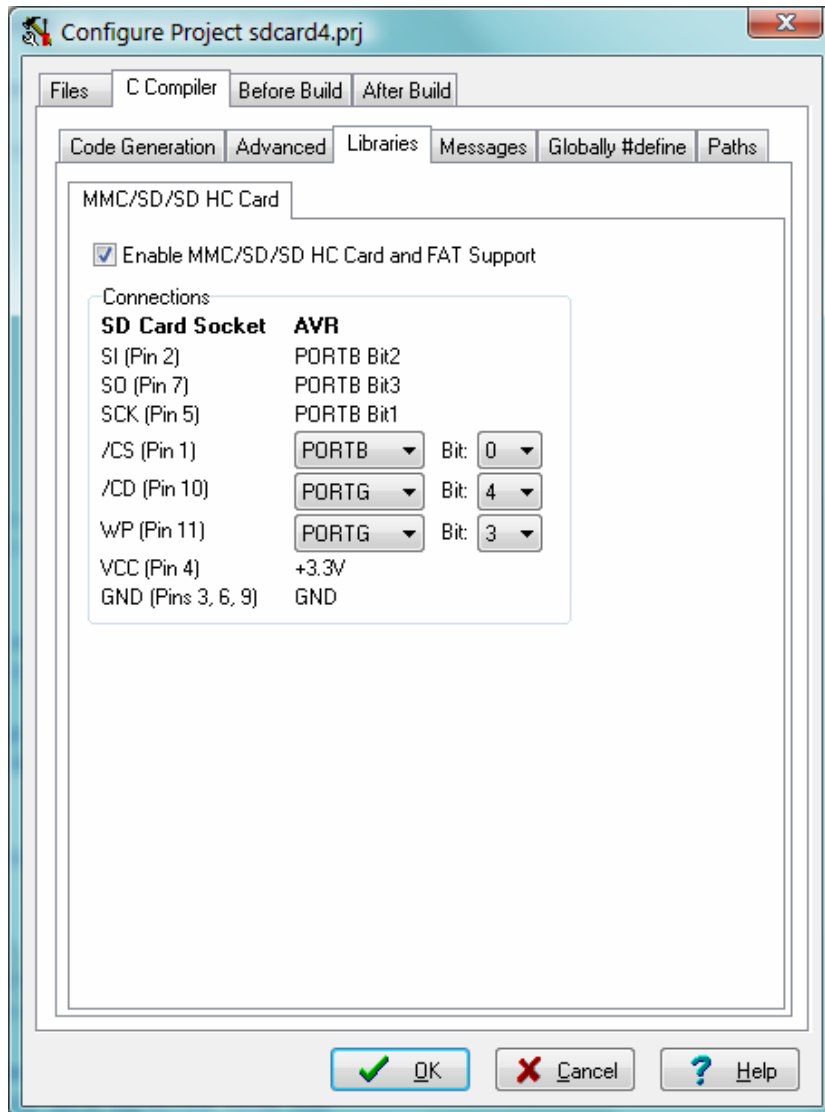

The **Enable MMC/SD/SD HC Card and FAT Support** check box activates the appropriate **FLASH Mmemory Card Drivers** and **FAT Access Functions** libraries.

CodeVisionAVR

The **Messages** tab allows to individually enable or disable various compiler and linker warnings:

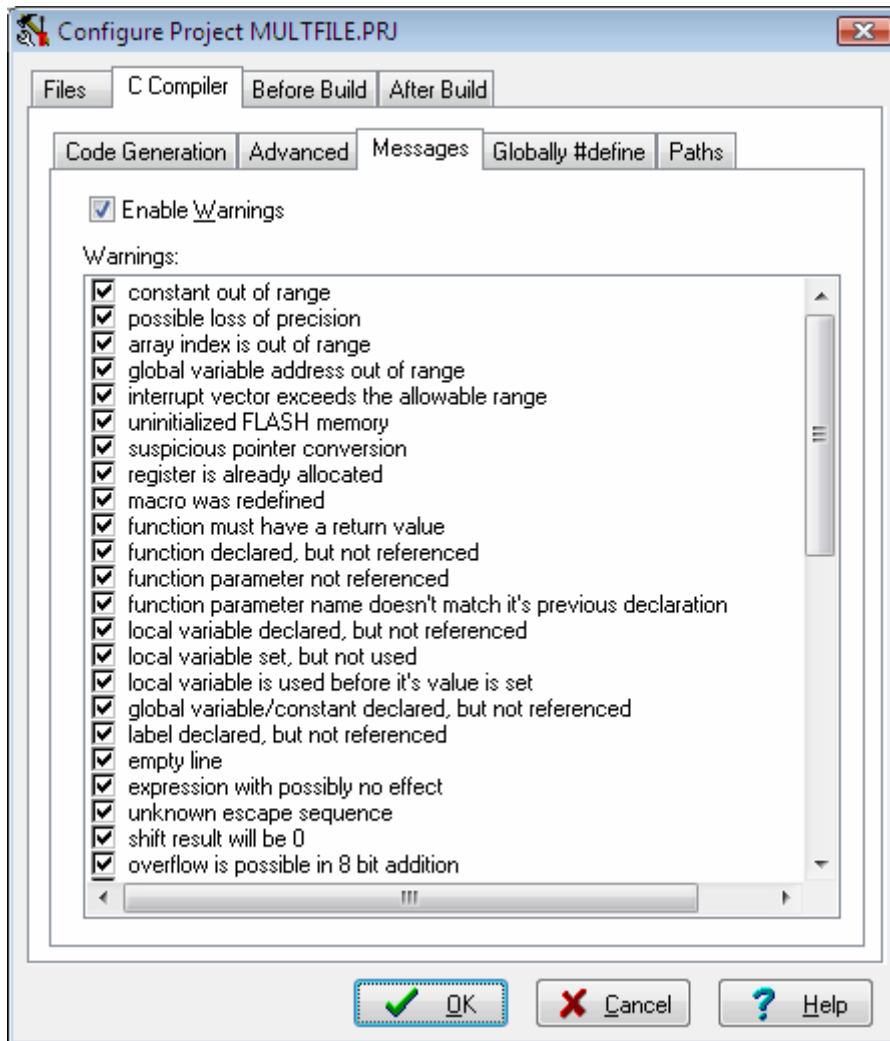

The generation of warning messages during compilation can be globally enabled or disabled by using the **Enable Warnings** check box.

CodeVisionAVR

The **Globally #define** tab allows to #define macros that will be visible in all the project files.
For example:

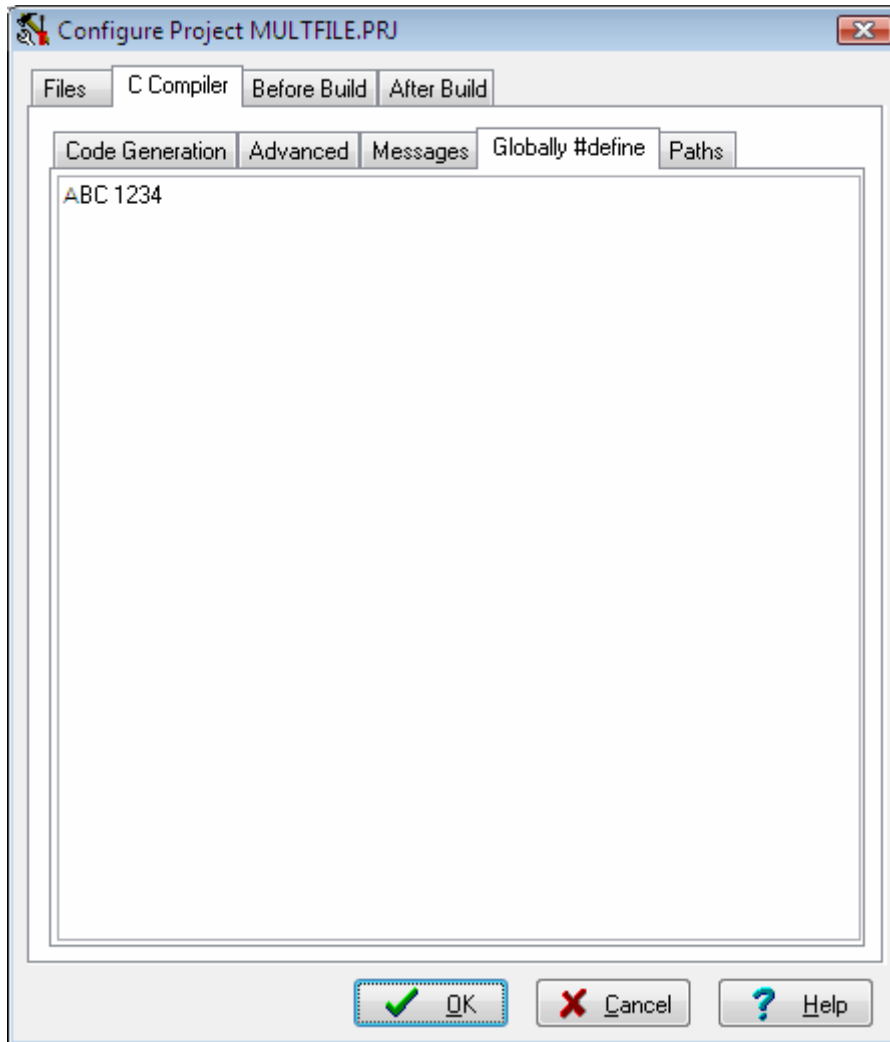

will be equivalent with placing the macro definition:

```
#define ABC 1234
```

in each project's program module.

CodeVisionAVR

The **Paths** tabs allows to specify additional paths for #include and library files. These paths must be entered one per line in the appropriate edit controls.

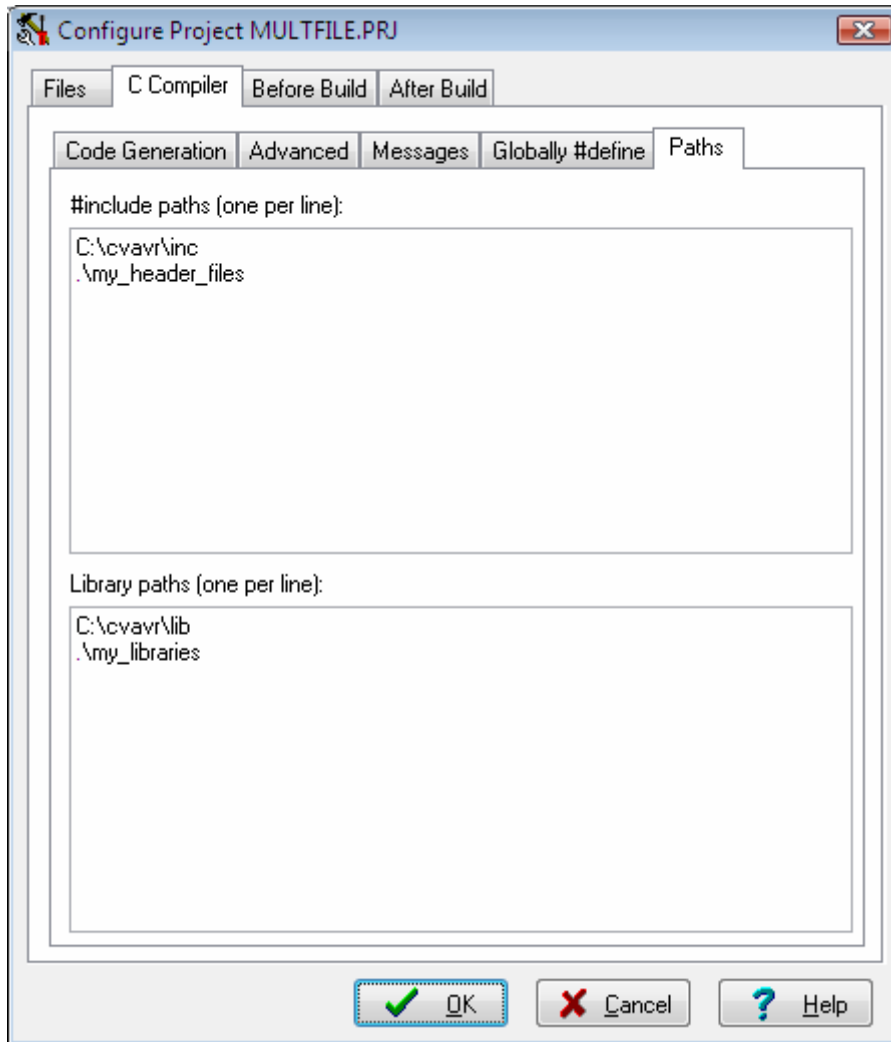

Changes can be saved, respectively canceled, using the **OK**, respectively **Cancel** buttons.

2.3.4.4 Executing an User Specified Program before Build

This option is available if you select the **Before Build** tab in the Project Configure window. If you check the **Execute User's Program** option, then a program, that you have previously specified, will be executed before the compilation/assembly process.

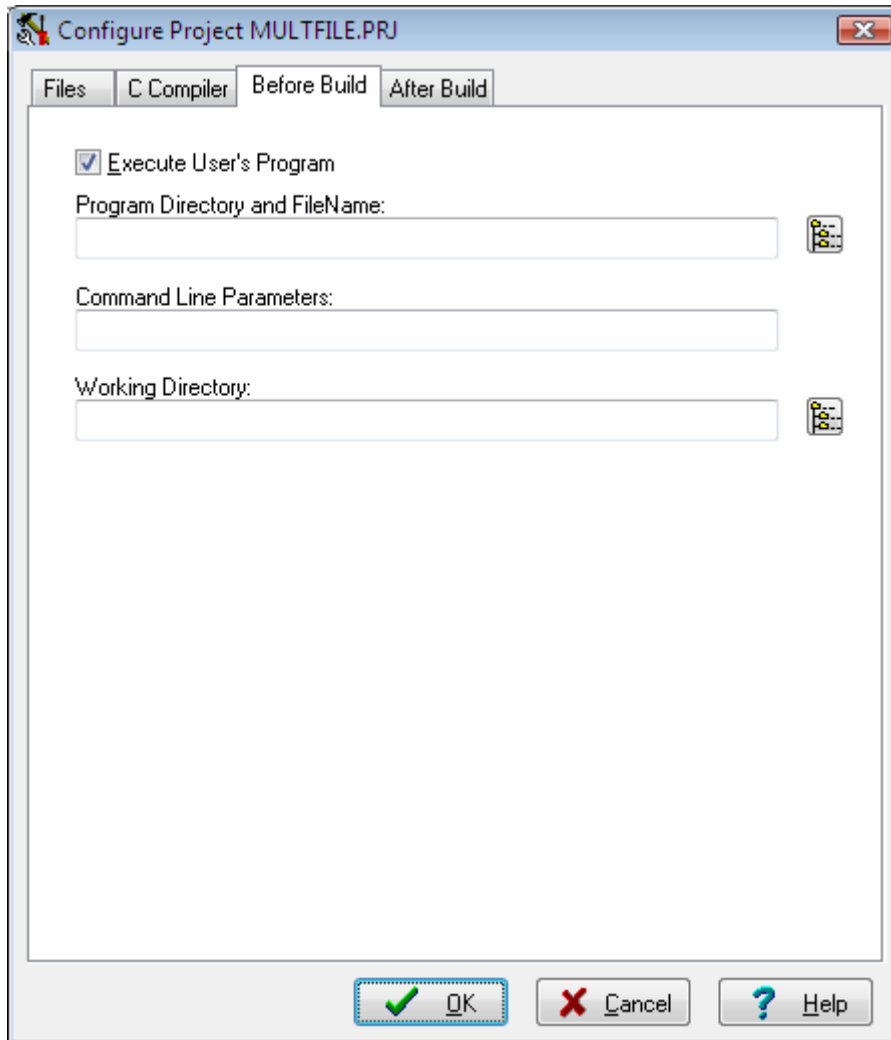

The following parameters can be specified for the program to be executed:

- Program Directory and File Name
- Program Command Line Parameters
- Program Working Directory.

2.3.4.5 Transferring the Compiled Program to the AVR Chip after Build

This option is available if you select the **After Build** tab in the Project Configure window.

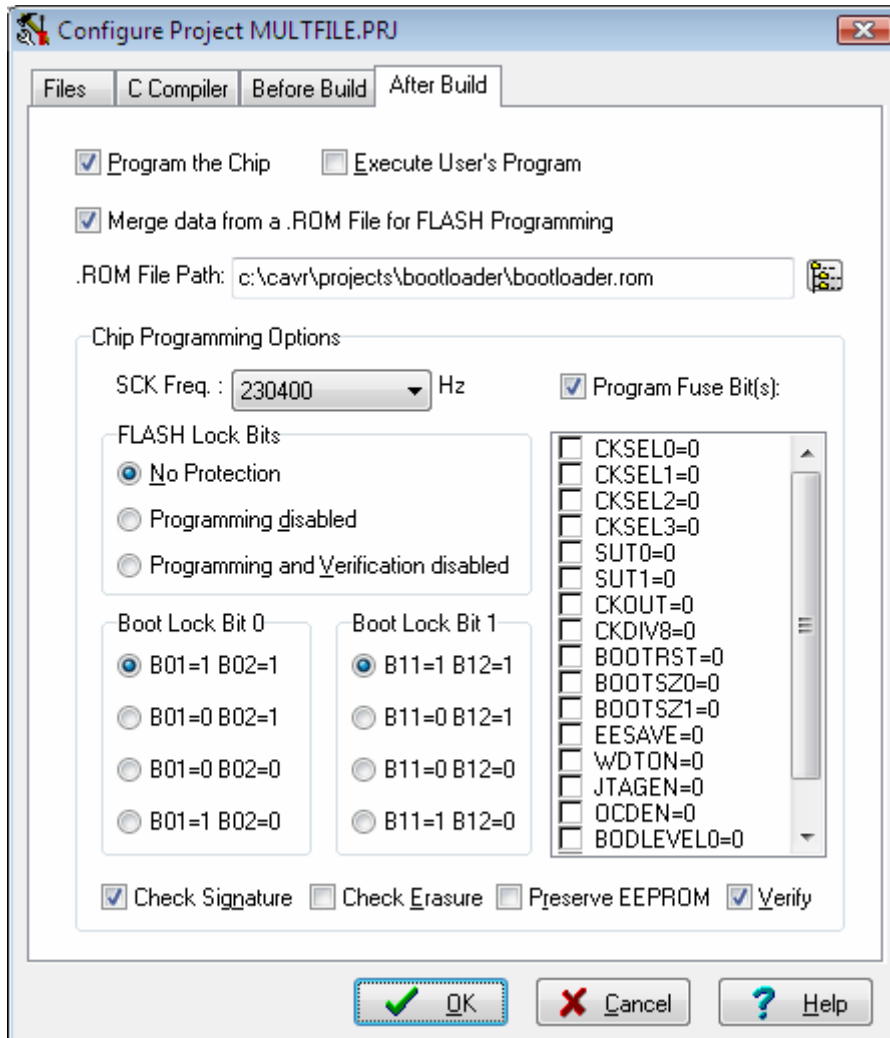

If you check the **Program the Chip** option, then after successful compilation/assembly your program will be automatically transferred to the AVR chip using the built-in Programmer software.

The following steps are executed automatically:

- Chip erasure
- FLASH and EEPROM blank check
- FLASH programming and verification
- EEPROM programming and verification
- Fuse and Lock Bits programming

CodeVisionAVR

The **Merge data from a .ROM File for FLASH Programming** option, if checked, will merge in the FLASH programming buffer the contents of the .ROM file, created by the compiler after Make, with the data from the .ROM file specified in **.ROM File Path**.

This is useful, for example, when adding a boot loader executable compiled in another project, to an application program that will be programmed in the FLASH memory.

You can select the type of the chip you wish to program using the **Chip** combo box.

The SCK clock frequency used for In-System Programming with the STK500, AVRISP or AVRISP MkII can be specified using the **SCK Freq.** listbox. This frequency must not exceed $\frac{1}{4}$ of the chip's clock frequency.

If the chip you have selected has Fuse Bit(s) that may be programmed, then a supplementary **Program Fuse Bit(s)** check box will appear.

If it is checked, then the chip's Fuse Bit(s) will be programmed after **Build**.

The Fuse Bit(s) can set various chip options, which are described in the Atmel data sheets.

If a Fuse Bit(s) check box is checked, then the corresponding fuse bit will be set to 0, the fuse being considered as programmed (as per the convention from the Atmel data sheets).

If a Fuse Bits(s) check box is not checked, then the corresponding fuse bit will be set to 1, the fuse being considered as not programmed.

If you wish to protect your program from copying, you must select the corresponding option using the **FLASH Lock Bits** radio box.

If you wish to check the chip's signature before programming you must use the **Check Signature** option.

To speed up the programming process you can uncheck the **Check Erasure** check box. In this case there will be no verification of the correctness of the FLASH erasure.

The **Preserve EEPROM** checkbox allows preserving the contents of the EEPROM during chip erasure.

To speed up the programming process you can uncheck the **Verify** check box. In this case there will be no verification of the correctness of the FLASH and EEPROM programming.

Changes can be saved, respectively canceled, using the **OK**, respectively **Cancel** buttons.

2.3.4.6 Executing an User Specified Program after Build

This option is available if you select the **After Build** tab in the Project Configure window. If you check the **Execute User's Program** option, then a program, that you have previously specified, will be executed after the compilation/assembly process.

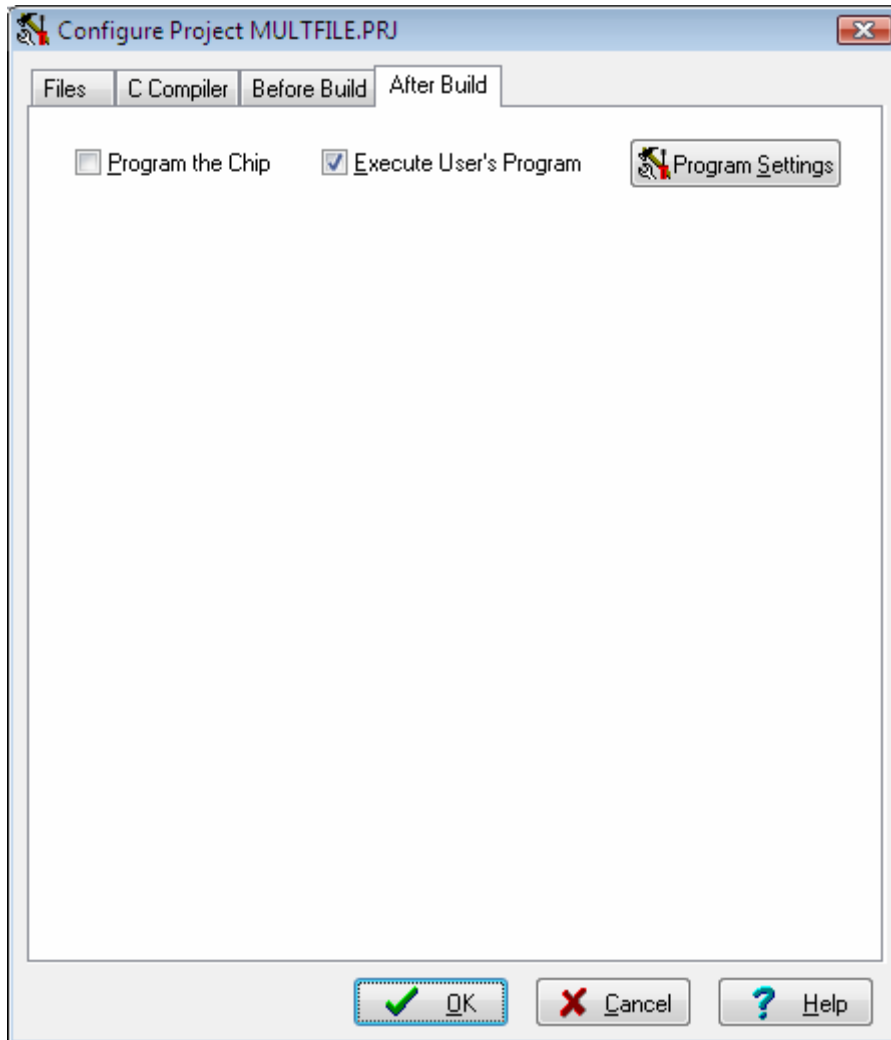

CodeVisionAVR

Using the **Program Settings** button you can modify the:

- Program Directory and File Name
- Program Command Line Parameters
- Program Working Directory

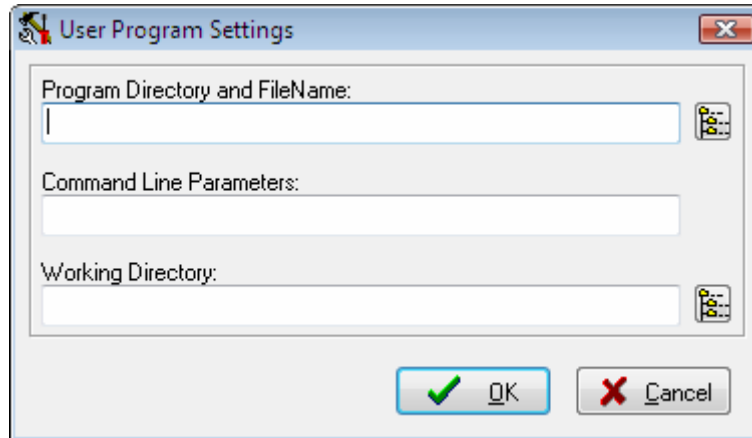

Pressing the  button allows to select a directory and file.
Changes can be saved, respectively canceled, using the **OK**, respectively **Cancel** buttons.

2.3.5 Obtaining an Executable Program

Obtaining an executable program requires the following steps:

1. Compiling the Project's C program modules, using the CodeVisionAVR C Compiler, and obtaining object files needed by the linker
2. Linking the object files files created during compilation and obtaining a single assembler source file
3. Assembling the assembler source file, using the Atmel AVR assembler AVRASM2.

Compiling, executes step 1.

Building, executes step 1, 2 and 3.

Compilation is performed only for the program modules that were modified since the previous similar process.

This leads to significant project build reduction times, compared with the old CodeVisionAVR V1.xx, where all the program modules were compiled even if they were not changed.

2.3.5.1 Checking Syntax

Checking the currently edited source file for syntax errors can be performed by using the

Project|Check Syntax menu or by pressing the  toolbar button.

This function is useful because it's faster than **Project|Compile** menu command, which compiles all the modified files in a project.

It can also be executed by selecting **Check Syntax** in the pop-up menu, which is invoked by right clicking with the mouse in the editor window.

CodeVisionAVR

2.3.5.2 Compiling the Project

To compile the Project you must use the **Project|Compile** menu command, press the **F9** key or the  button of the toolbar. The CodeVisionAVR C Compiler will be executed, producing the object files needed by the linker.

Compilation will be performed only for the program modules that were modified since the previous similar process.

The compilation process can be stopped using the **Project|Stop Compilation** menu command or by pressing the  button on the toolbar.

After the compilation is complete, an **Information** window will open, showing the compilation results.

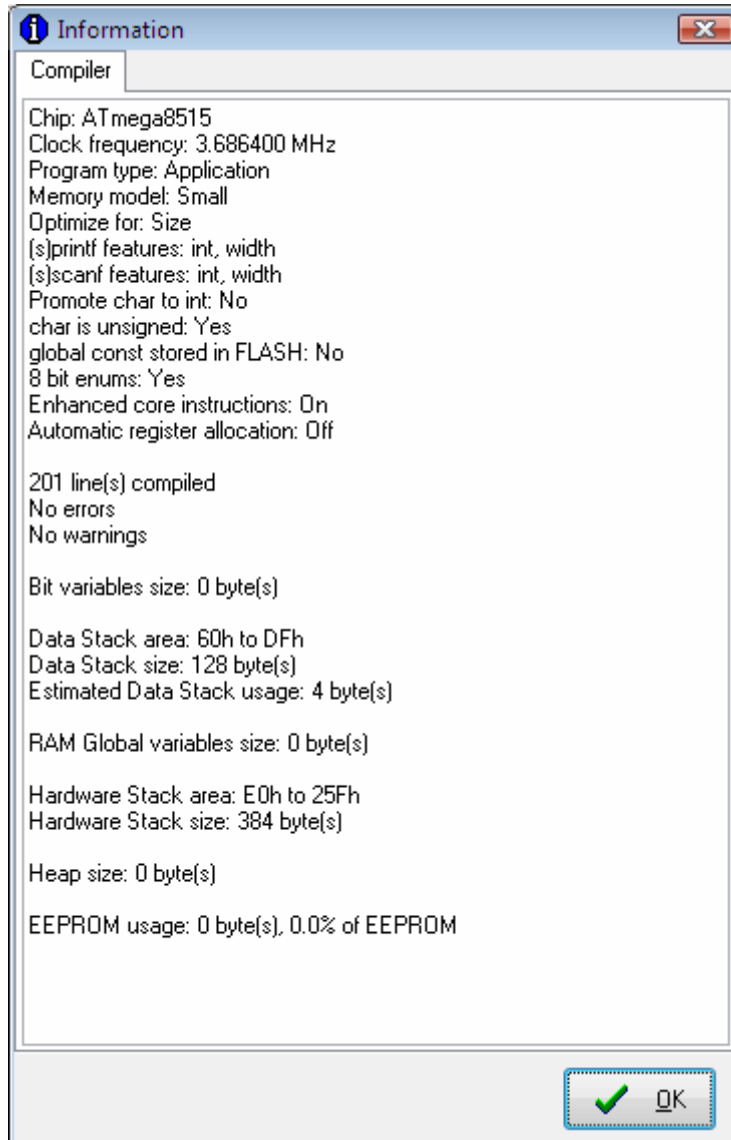

CodeVisionAVR

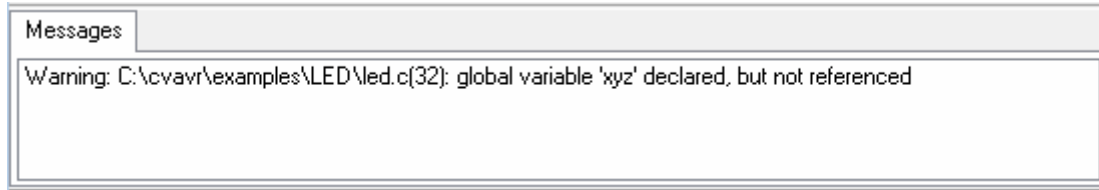

Eventual compilation errors and/or warnings will be listed in the **Message** window located under the **Editor** window, or in the **Code Navigator** window.

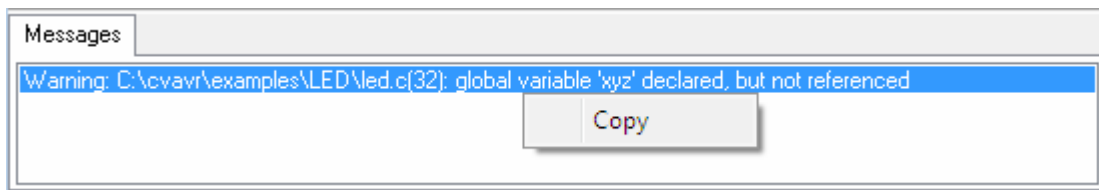

By left clicking with the mouse on the error or warning message, the source line with the problem will be highlighted.
Right clicking with mouse opens a pop-up menu that contains the option to **Copy** the error message to the clipboard:



The **Project|Go to Next Error**, respectively **Project|Go to Previous Error** menu commands, the **F8**, respectively **Ctrl+F8** keys or the , respectively  toolbar buttons, allow moving to the next, respectively previous error message.

The **Project|Go to Next Warning**, respectively **Project|Go to Previous Warning** menu commands, the **F4**, respectively **Ctrl+F4** keys or the , respectively  toolbar buttons, allow moving to the next, respectively previous warning message.

If the message refers also to a previous declaration or definition from a file that is different than the one where the error was signaled, right clicking with the mouse opens a pop-up menu with the **Jump to Previous Declaration or Definition** option:

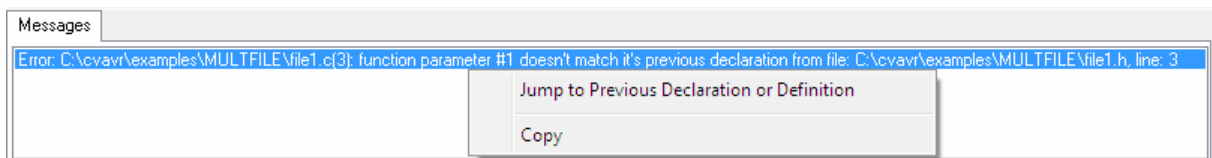

Selecting this option will highlight the source line where the previous declaration or definition was made.

The size of the **Message** window can be modified using the horizontal slider bar placed between it and the **Editor** window.

CodeVisionAVR

2.3.5.3 Building the Project

To build the Project you must use the **Project|Build** menu command, press the **Shift+F9** keys or the  button of the toolbar. The CodeVisionAVR C Compiler will be executed, producing the object files needed by the linker.

Compilation will be performed only for the program modules that were modified since the previous similar process.

If the complete recompilation of all the program modules is needed, then the **Project|Build All** menu command or the  button of the toolbar must be used.



After successful compilation the object files will be linked and an assembly .asm file will be produced. If no compilation or linking errors were encountered, then the Atmel AVR assembler AVRASM2 will be executed, obtaining the output file types specified in **Project|Configure|C Compiler|Code Generation**.

The build process can be stopped using the **Project|Stop Compilation** menu command or by pressing the  button on the toolbar.

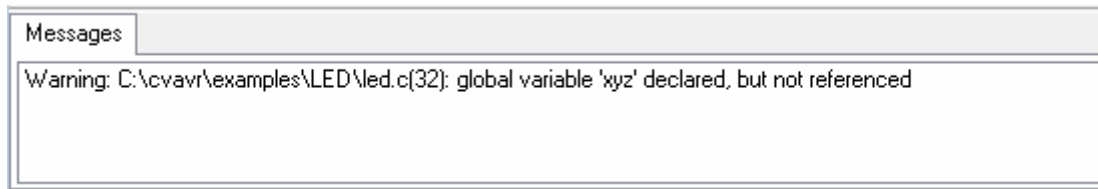
Eventual compilation errors and/or warnings will be listed in the **Message** window located under the **Editor** window, or in the **Code Navigator** window.



The **Project|Go to Next Error**, respectively **Project|Go to Previous Error** menu commands, the **F8**, respectively **Ctrl+F8** keys or the , respectively  toolbar buttons, allow moving to the next, respectively previous error message.

The **Project|Go to Next Warning**, respectively **Project|Go to Previous Warning** menu commands, the **F4**, respectively **Ctrl+F4** keys or the , respectively  toolbar buttons, allow moving to the next, respectively previous warning message.

By left clicking with the mouse on the error or warning message, the source line with the problem will be highlighted.

Right clicking with mouse opens a pop-up menu that contains the option to **Copy** the error message to the clipboard:

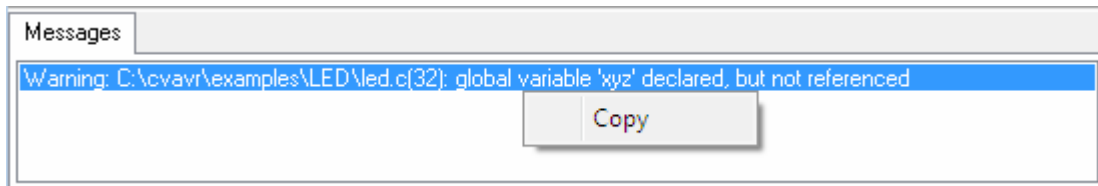

CodeVisionAVR

If the message refers also to a previous declaration or definition from a file that is different than the one where the error was signaled, right clicking with the mouse opens a pop-up menu with the **Jump to Previous Declaration or Definition** option:

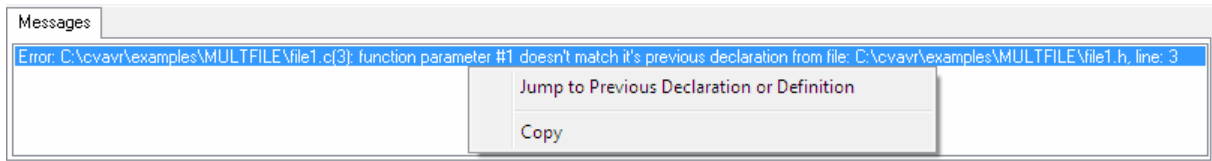

Selecting this option will highlight the source line where the previous declaration or definition was made.

After the build process is completed, an **Information** window will open showing the build results. Pressing the **Compiler** tab will display compilation results.

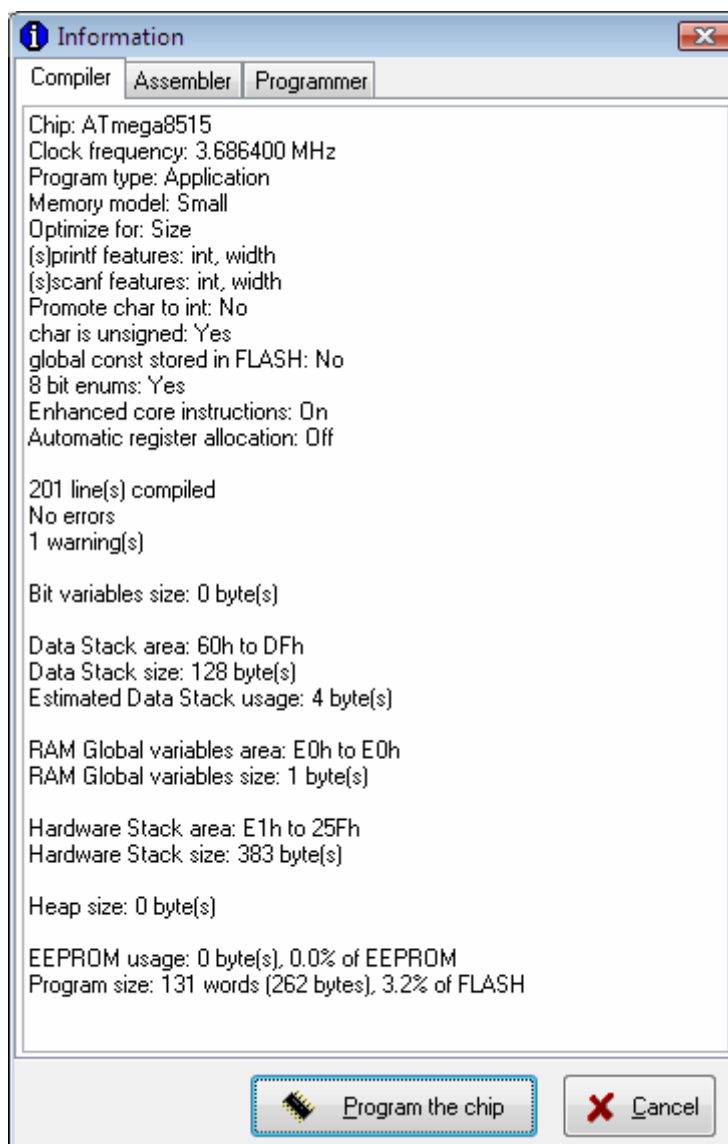

CodeVisionAVR

Pressing the **Assembler** tab will display assembly results.

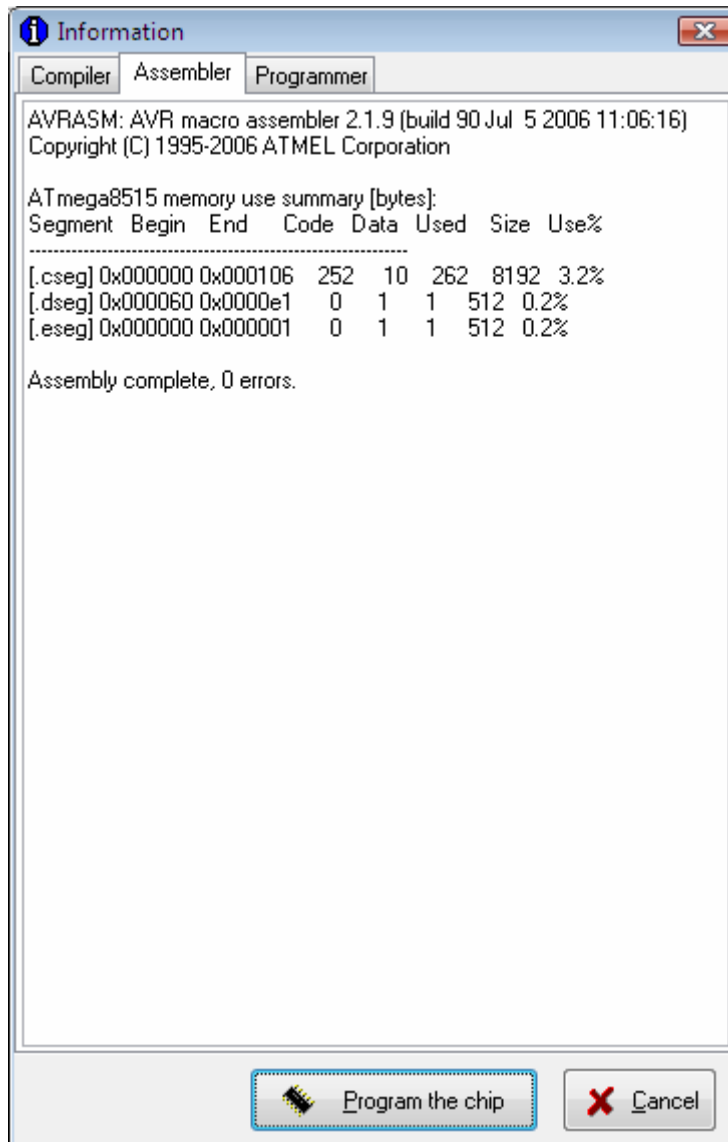

CodeVisionAVR

Pressing the **Programmer** tab will display the **Chip Programming Counter**, which shows how many times was the AVR chip programmed so far.

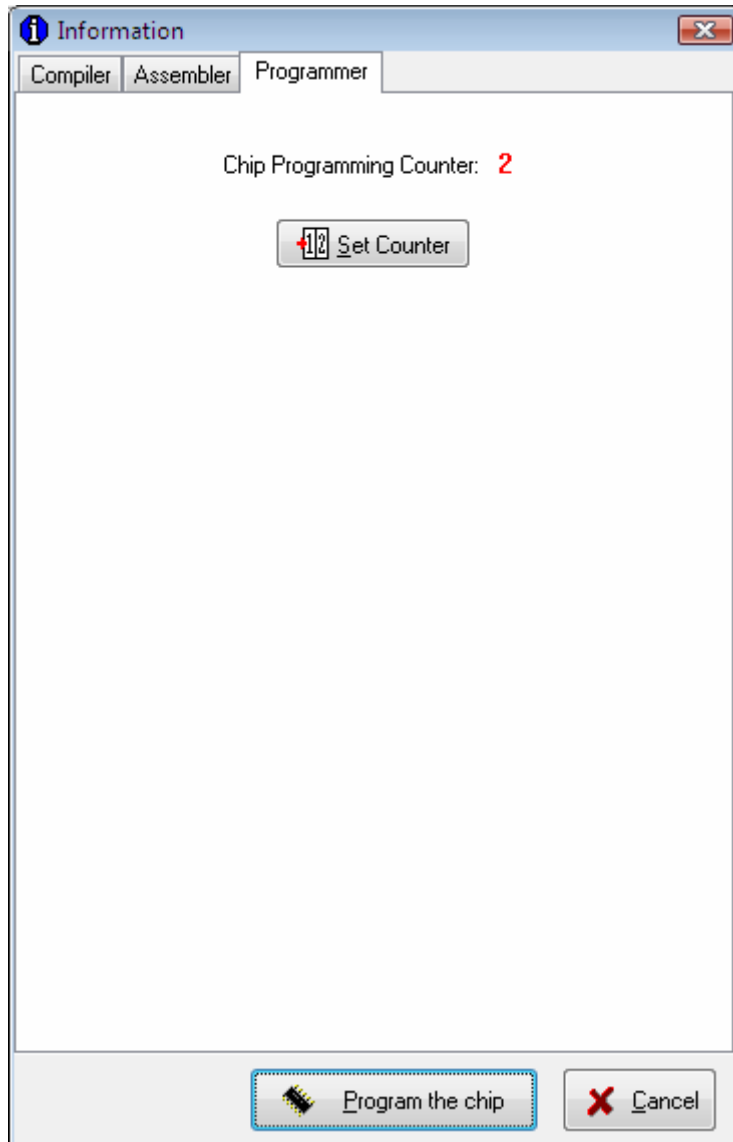

Pressing the **Set Counter** button will open the **Set Programming Counter** window:

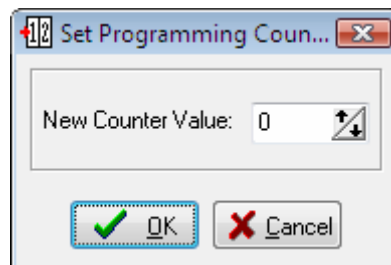

This dialog window allows setting the new **Chip Programming Counter** value.

Pressing the **Program the chip** button allows automatic programming of the AVR chip after successful build. Pressing **Cancel** will disable automatic programming.

2.3.5.4 Cleaning Up the Project Output Directories

The various files created during the **Project Build** process can be deleted using the **Project|Clean Up** menu or by pressing the  button on the toolbar.

The following **Project Output Directories** will be cleaned:



- **Object Files** directory - all files will be deleted, except the .cof COFF object file
- **List Files** directory - all files will be deleted, except the .asm and .vec assembly source files
- **Linker Files** directory – all files will be deleted.



CodeVisionAVR

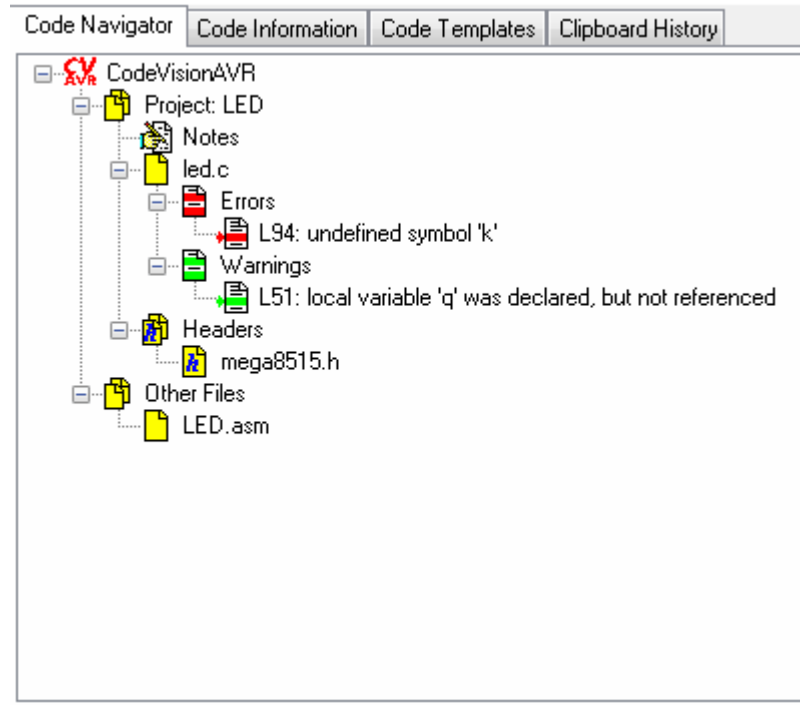

2.3.5.5 Using the Code Navigator

The **Code Navigator** window allows displaying or opening of the project source files, along with errors or warnings that occurred during the compile or build processes.



The project's program modules are listed as children of the **Project**  node. Other opened files, that are not part of the project, are listed as children of the **Other Files**  node. By clicking on a file  node, the appropriate file is maximized or opened.

After a **Compile** or **Build** process there is also displayed a list of header .h files that were #included in the project's program modules during this process. The headers files are available as children of the **Headers**  node. By clicking on a header file  node, the appropriate header file is maximized or opened.

If during compilation there are errors or warnings, these are also displayed in the **Code Navigator** window. By clicking on the error  or warning  node, the corresponding source line is highlighted in the appropriate file.

The **Code Navigator** tree branches can be expanded, respectively collapsed, by clicking on the **+**, respectively **-**, buttons.

By right clicking in the **Code Navigator** window you can open a pop-up menu with the following choices:

- **Open** a file
- **Save** the currently edited file
- **Save All** opened files
- **Close** currently edited file
- **Close All** opened files
- Toggle on or off alphabetically sorting the files in the **Code Navigator**
- Toggle on or off expanding the **Errors** and **Warnings** branches after a **Compile** or **Build** process
- Toggle on or off expanding the header file branches.

2.3.5.6 Using the Code Information

The **Code Information** window allows for easy access to declarations and definitions made in the currently edited source file.

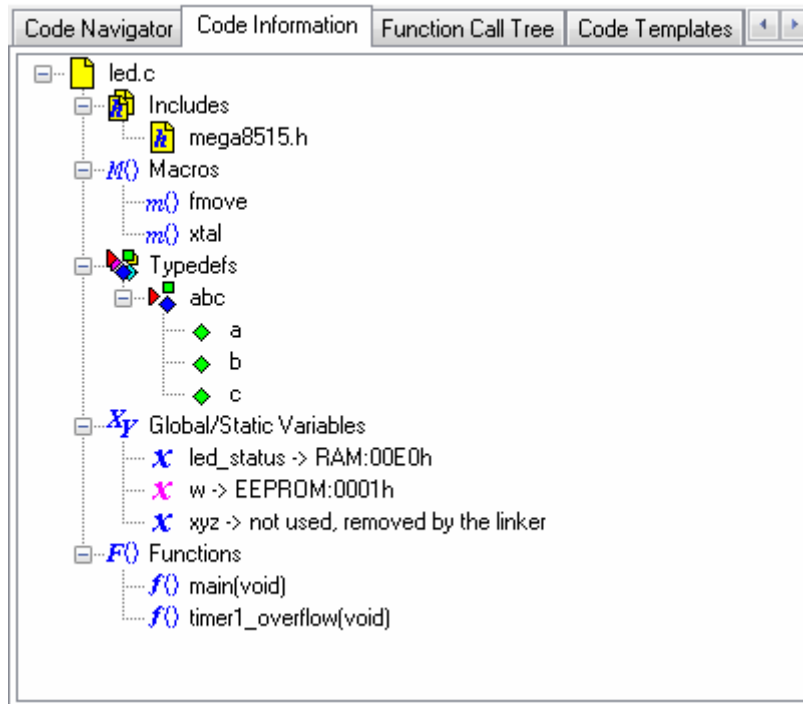

The **Code Information** window is accessed using the tab with the same name and appears after the first **Compile** or **Build** process of the currently opened project.

The information is displayed in the form of a tree with several types of nodes:

- **Includes** node which displays all the header .h files #included in the currently edited source file. Clicking on a header node moves the cursor to the corresponding *#include* directive in the edited source file.
- **Macros** node which displays all the preprocessor macros defined in the currently edited source file. Clicking on a macro node moves the cursor to the corresponding *#define* directive in the edited source file.
- **Typedefs** node which displays all the data types defined in the currently edited source file. Clicking on a type definition node moves the cursor to the corresponding data type definition in the edited source file. If the defined data type is a structure, union or enumeration, then it's members are displayed as additional nodes.
- **Global/Static Variables** node which displays all the global and static variables declared in the currently edited source file. Clicking on a RAM variable node or EEPROM variable node moves the cursor to the corresponding declaration in the edited source file.
- **Global Constants** node which displays all the global constants declared in the currently edited source file. Clicking on a constant node moves the cursor to the corresponding declaration in the edited source file.
- **Functions** node which displays all the functions that were defined in the currently edited source file. Clicking on a function node moves the cursor to the corresponding definition in the edited source file.

The **Code Information** tree branches can be expanded, respectively collapsed, by clicking on the **+**, respectively **-**, buttons.

CodeVisionAVR

By right clicking in the **Code Information** window you can open a pop-up menu with the following choices:

- Toggle on or off alphabetically sorting the items in the **Code Information** tree
- Toggle on or off expanding the **Code Information** tree branches.

2.3.5.7 Using the Function Call Tree

The **Function Call Tree** window displays the function call sequence that uses the largest amount of Data Stack during program execution.

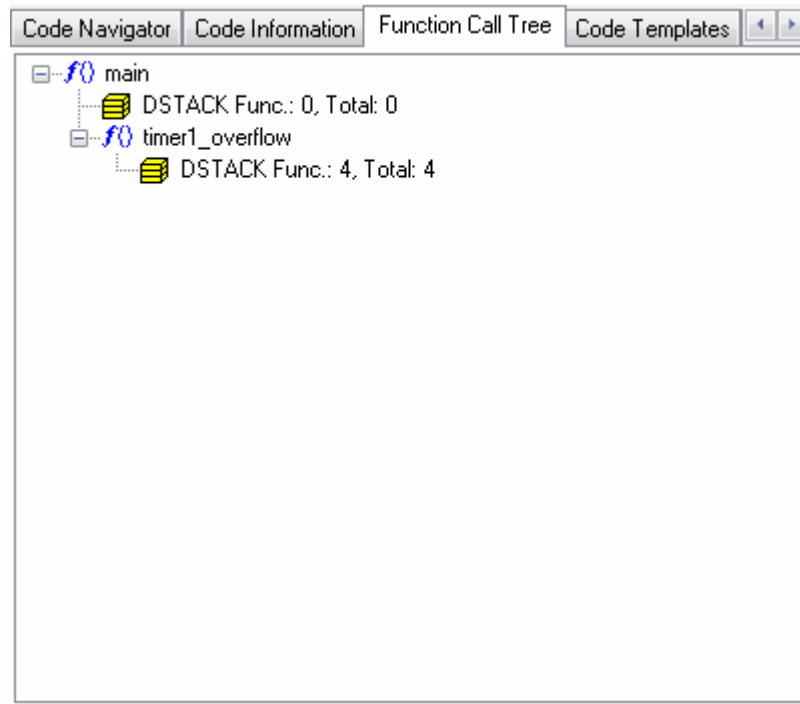

The **Function Call Tree** window is accessed using the tab with the same name and appears after the first **Compile** or **Build** process of the currently opened project.

The Data Stack usage information is represented in the form of a tree with two types of nodes:

- Function **f()** nodes. Clicking on a function name moves the cursor to the corresponding definition in the source file.
- DSTACK **DSTACK** nodes display the data stack used by the parent function and the total level of the Data Stack when the program is executed inside the function.

2.3.6 Closing a Project

You can quit working with the current Project by using the **File|Close Project** menu command or the  toolbar button.

If the Project files were modified, and were not saved yet, you will be asked if you want to do that.

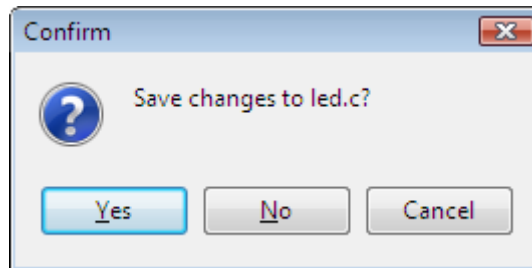

Pressing **Yes** will save changes and close the project.

Pressing **No** will close the project without saving the changes.

Pressing **Cancel** will disable the project closing process.

When saving, the IDE will create a backup file with a **.prj~** extension.

CodeVisionAVR

2.4 Tools

Using the **Tools** menu you can execute other programs without exiting the CodeVisionAVR IDE.

2.4.1 The AVR Studio Debugger

The CodeVisionAVR C Compiler is designed to work in conjunction with the Atmel AVR Studio debugger version 4.14 or later, for which it will generate an extended COFF object file that allows watching structures and unions.

Older versions of AVR Studio don't support the extended COFF object file format, so these can't be used with CodeVisionAVR.

Before you can invoke the debugger, you must first specify its location and file name using the **Settings|Debugger** menu command.

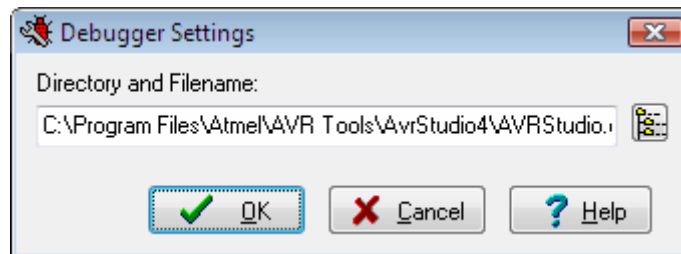

Pressing the  button allows to select the debugger's directory and file. Changes can be saved, respectively canceled, using the **OK**, respectively **Cancel** buttons.

The debugger is executed by selecting the **Tools|Debugger** menu command or by pressing the  button on the toolbar.

2.4.2 The AVR Chip Programmer

The CodeVisionAVR IDE has a built-in **In-System AVR Chip Programmer** that lets you easily transfer your compiled program to the microcontroller for testing.

The Programmer is designed to work with the Atmel STK500, AVRISP, AVRISP MkII, AVR Dragon, JTAGICE MkII, AVRProg (AVR910 application note), Kanda Systems STK200+, STK300, Dontronics DT006, Vogel Elektronik VTEC-ISP, Futurlec JRAVR or the MicroTronics ATCPU, Mega2000 development boards.

The type of the used programmer and the printer port can be selected by using the **Settings|Programmer** menu command.

The Programmer is executed by selecting the **Tools|Chip Programmer** menu command or by pressing the  button on the toolbar.

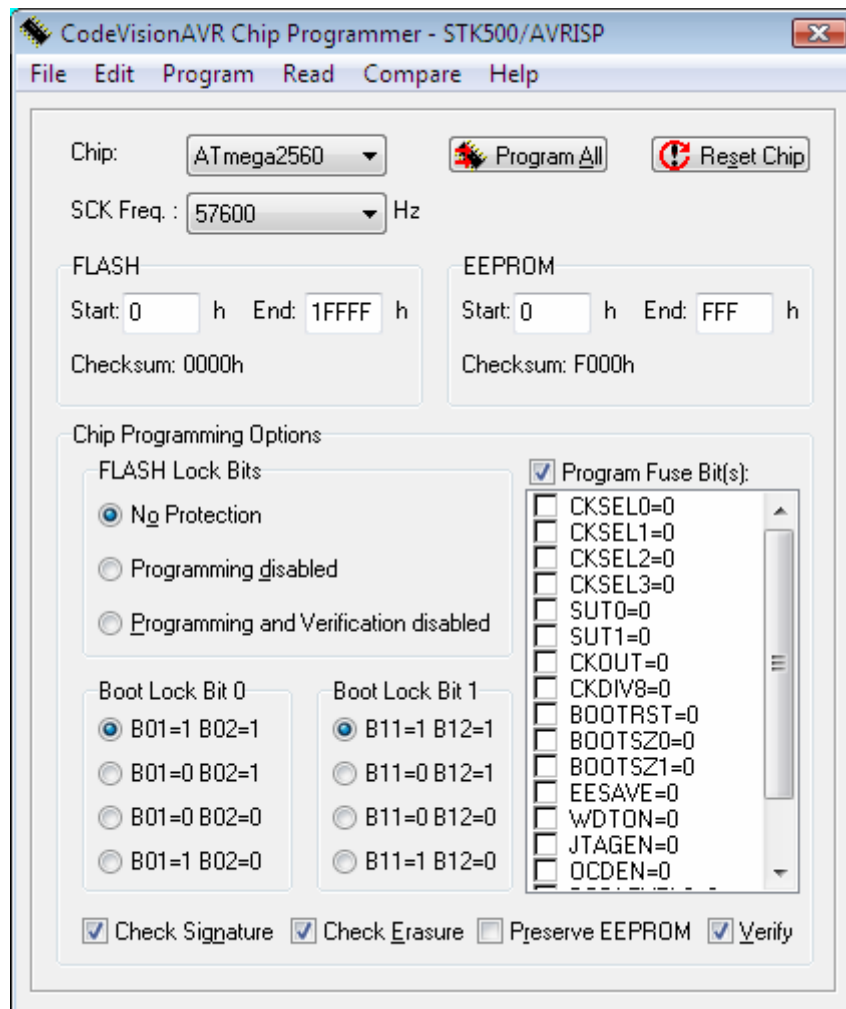

You can select the type of the chip you wish to program using the **Chip** combo box.

CodeVisionAVR

The SCK clock frequency used for In-System Programming with the STK500, AVRISP or AVRISP MkII can be specified using the **SCK Freq.** listbox. This frequency must not exceed $\frac{1}{4}$ of the chip's clock frequency.

If the chip you have selected has Fuse Bit(s) that may be programmed, then a supplementary **Program Fuse Bit(s)** check box will appear. If it is checked, then the chip's Fuse Bit(s) will be programmed when the **Program|All** menu command is executed or when the  **Program All** button is pressed.

The Fuse Bit(s) can set various chip options, which are described in the Atmel data sheets. If a Fuse Bit(s) check box is checked, then the corresponding fuse bit will be set to 0, the fuse being considered as programmed (as per the convention from the Atmel data sheets). If a Fuse Bits(s) check box is not checked, then the corresponding fuse bit will be set to 1, the fuse being considered as not programmed.

If you wish to protect your program from copying, you must select the corresponding option using the **FLASH Lock Bits** radio box.

The Programmer has two memory buffers:

- The FLASH memory buffer
- The EEPROM memory buffer.

You can Load or Save the contents of these buffers using the **File** menu.

Supported file formats are:

- Atmel .rom and .eep
- Intel HEX
- Binary .bin

After loading a file in the corresponding buffer, the **Start** and **End** addresses are updated accordingly. You may also edit these addresses if you wish.

The contents of the FLASH, respectively EEPROM, buffers can be displayed and edited using the **Edit|FLASH**, respectively **Edit|EEPROM** menu commands.

When one of these commands is invoked, an Edit window displaying the corresponding buffer contents will open:

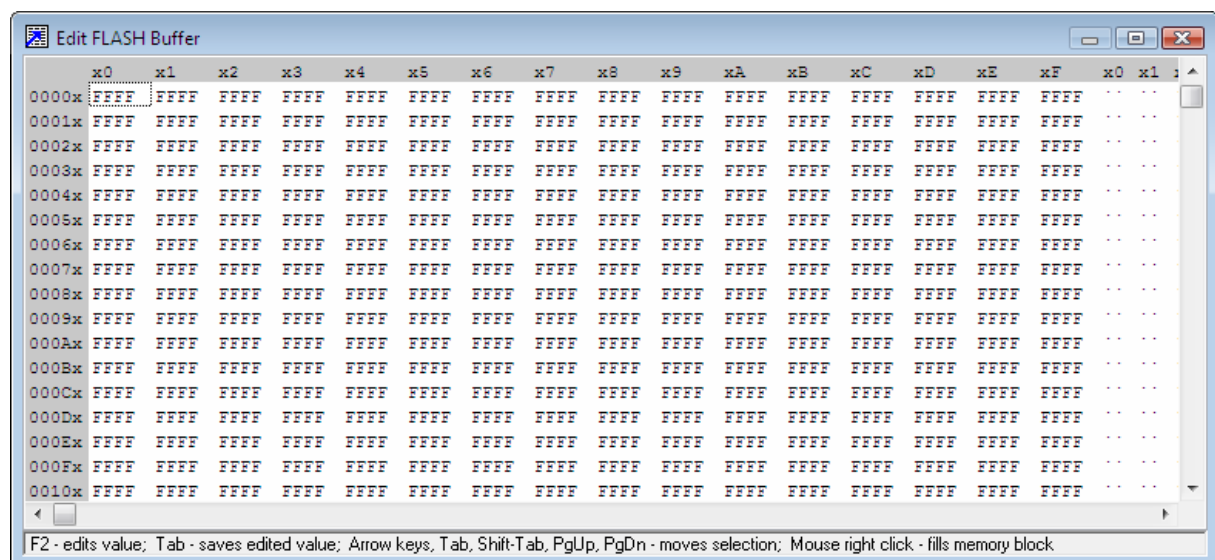

The buffer's contents, at the highlighted address, can be edited by pressing the **F2** key and typing in the new value. The edited value is saved by pressing the **Tab** or **arrow** keys.

The highlighted address can be modified using the **arrow**, **Tab**, **Shift+Tab**, **PageUp** or **PageDown** keys.

CodeVisionAVR

The **Fill Memory Block** window can be opened by right clicking in the Edit window:

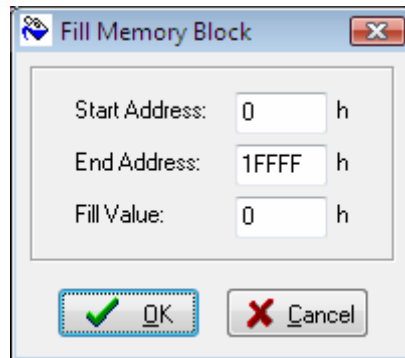

This window lets you specify the **Start Address**, **End Address** and **Fill Value** of the memory area to be filled.

If you wish to check the chip's signature before any operation you must use the **Check Signature** option.

To speed up the programming process you can uncheck the **Check Erasure** check box. In this case there will be no verification of the correctness of the FLASH erasure.

The **Preserve EEPROM** checkbox allows preserving the contents of the EEPROM during chip erasure.

To speed up the programming process you also can uncheck the **Verify** check box. In this case there will be no verification of the correctness of the FLASH and EEPROM programming.

For erasing a chip's FLASH and EEPROM you must select the **Program|Erase** menu command. After erasure the chip's FLASH and EEPROM are automatically blank checked.

For simple blank checking you must use the **Program|Blank Check** menu command.

If you wish to program the FLASH with the contents of the FLASH buffer you must use the **Program|FLASH** menu command.

For programming the EEPROM you must use the **Program|EEPROM** menu command.

After programming the FLASH and EEPROM are automatically verified.

To program the Lock, respectively the Fuse Bit(s) you must use the **Program|Fuse Bit(s)**, respectively **Program|Lock Bits** menu commands.

The **Program|All** menu command allows to automatically:

- Erase the chip
- FLASH and EEPROM blank check
- Program and verify the FLASH
- Program and verify the EEPROM
- Program the Fuse and Lock Bits.

If you wish to read the contents of the chip's FLASH, respectively EEPROM, you must use the **Read|FLASH**, respectively **Read|EEPROM** menu commands.

For reading the chip's signature you must use the **Read|Chip Signature** menu command.

To read the Lock, respectively the Fuse Bits you must use the **Read|Lock Bits**, respectively **Read|Fuse Bits** menu commands.

For some devices there's also the **Read|Calibration Byte(s)** option available.

It allows reading the value of the calibration bytes of the chip's internal RC oscillator.

CodeVisionAVR

If the programmer is an Atmel STK500, AVRISP, AVRISP MkII or AVRProg (AVR910 application note), then an additional menu command is present: **Read|Programmer's Firmware Version**. It allows reading the major and minor versions of the above mentioned programmers' firmware.

For comparing the contents of the chip's FLASH, respectively EEPROM, with the corresponding memory buffer, you must use the **Compare|FLASH**, respectively **Compare|EEPROM** menu commands.

For exiting the Programmer and returning to the CodeVisionAVR IDE you must use the **File|Close** menu command.

2.4.3 The Serial Communication Terminal

The **Terminal** is intended for debugging embedded systems, which employ serial communication (RS232, RS422, RS485).

The Terminal is invoked using the **Tools|Terminal** menu command or the  button on the toolbar.

The characters can be displayed in ASCII or hexadecimal format. The display mode can be toggled using the **Hex/ASCII** button.

The received characters can be saved to a file using the **Rx File** button.

Any characters typed in the Terminal window will be transmitted through the PC serial port.

The entered characters can be deleted using the **Backspace** key.

By pressing the **Send** button, the Terminal will transmit a character whose hexadecimal ASCII code value is specified in the Hex Code edit box.

By pressing the **Tx File** button, the contents of a file can be transmitted through the serial port.

By pressing the **Reset** button, the AVR chip on the STK200+/300, VTEC-ISP, DT006, ATCPU or Mega2000 development board is reseted.

At the bottom of the Terminal window there is a status bar in which are displayed the:

- computer's communication port;
- communication parameters;
- handshaking mode;
- received characters display mode;
- type of emulated terminal;
- the state of the transmitted characters echo setting.

CodeVisionAVR

2.4.4 Executing User Programs

User programs are executed by selecting the corresponding command from the **Tools** menu. You must previously add the Program's name to the menu.

2.4.5 Configuring the Tools Menu

You can add or remove User Programs from the **Tools** menu by using the **Tools|Configure** menu command.

A **Configure Tools** dialog window, with a list of User Programs, will open.

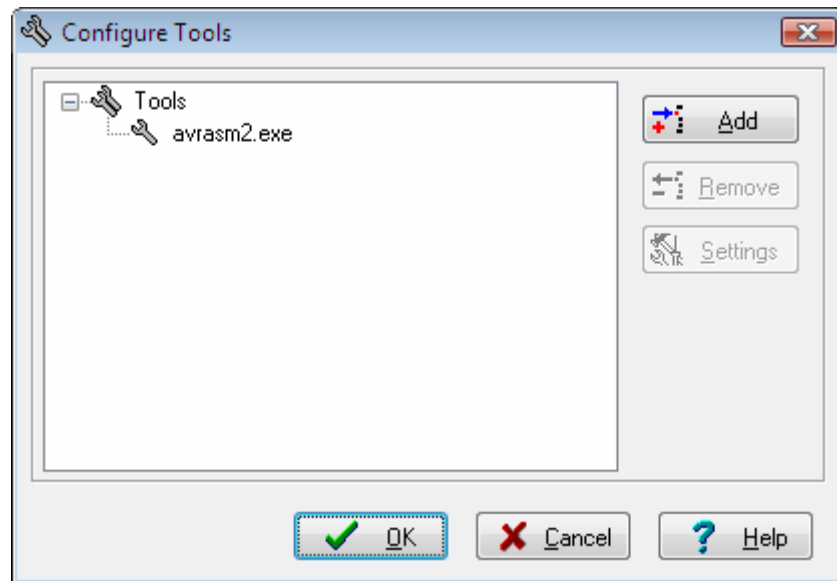

Using the **Add** button you can add a Program to the **Tools** menu.

Using the **Remove** button you can remove a Program from the **Tools** menu.

CodeVisionAVR

Using the **Settings** button you can modify the:

- Tool Menu Name
- Tool Directory and File Name
- Command Line Parameters
- Working Directory of a selected Program from the list

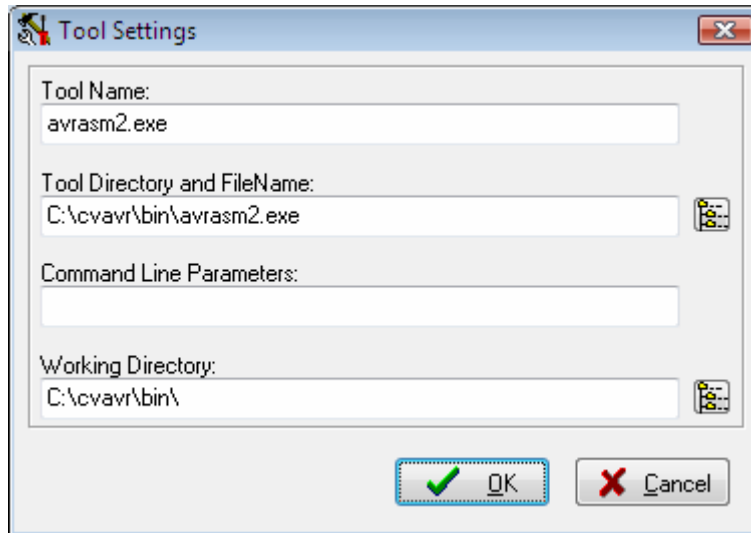

Changes can be saved, respectively canceled, using the **OK**, respectively **Cancel** buttons.

The command line can accept the following parameters:

- %P substitutes the full project path
- %p substitutes the project name without path
- %h substitutes the name of the .hex file created by the compiler
- %e substitutes the name of the .eep file created by the compiler
- %f<project_file_number> substitutes the project's source file name without path
- %F<project_file_number> substitutes the project's source file name with full path.



CodeVisionAVR

2.5 IDE Settings

The CodeVisionAVR IDE is configured using the **View** and **Settings** menus.

2.5.1 The View Menu

The following settings can be configured using the **View** menu command:

- The **View|Visible Non-Printable Characters** option allows to turn on or off the displaying of non-printable characters in the Editor window. The  toolbar button can be also used for this purpose.
- The **View|Toolbar** option allows to turn on or off the displaying of the various toolbars containing the IDE command buttons;
- The **View|Code Navigator/Code Information/Code Templates/Clipboard History** option allows to turn on or off the displaying of the **Navigator**, **Code Templates** and **Clipboard History** window at the left of the **Editor** window. The  toolbar button can be also used for this purpose;
- The **View|Messages** option allows to turn on or off the displaying of the **Message** window located under the **Editor** window. The  toolbar button can be also used for this purpose;
- The **View|Information Window after Compile/Build** option allows to turn on or off the displaying of the **Information** window after the **Compile** or **Build** processes.

2.5.2 General IDE Settings

Some general IDE settings can be specified using the **Settings|IDE** menu or the  toolbar button. These settings are:

- Load Last Used Project at Startup
- Show Hint for the **Code Navigator** window
- Show Hint for the **Code Information** window
- Show Hint for the **Function Call Tree** window.

The settings can be enabled or disabled by checking or unchecking the appropriate check boxes:

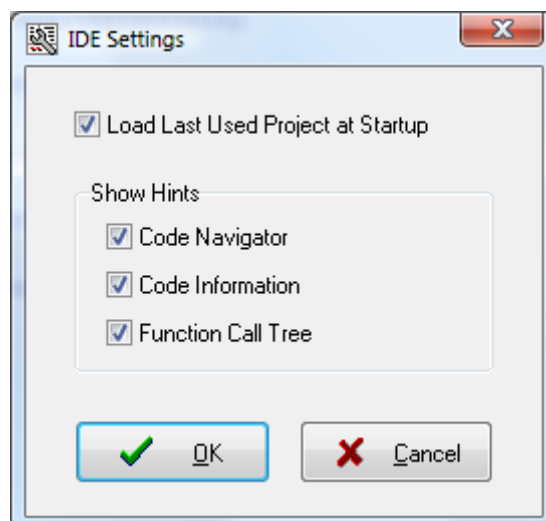

Changes can be saved, respectively canceled, using the **OK**, respectively **Cancel** buttons.

2.5.3 Configuring the Editor

The Editor can be configured using the **Settings|Editor** menu command.

The Editor configuration changes can be saved, respectively canceled, using the **OK**, respectively **Cancel** buttons.

By pressing the **Default** button the default Editor settings are restored.

2.5.3.1 General Editor Settings

The following groups of Editor settings can be established by clicking on the **General** tab:

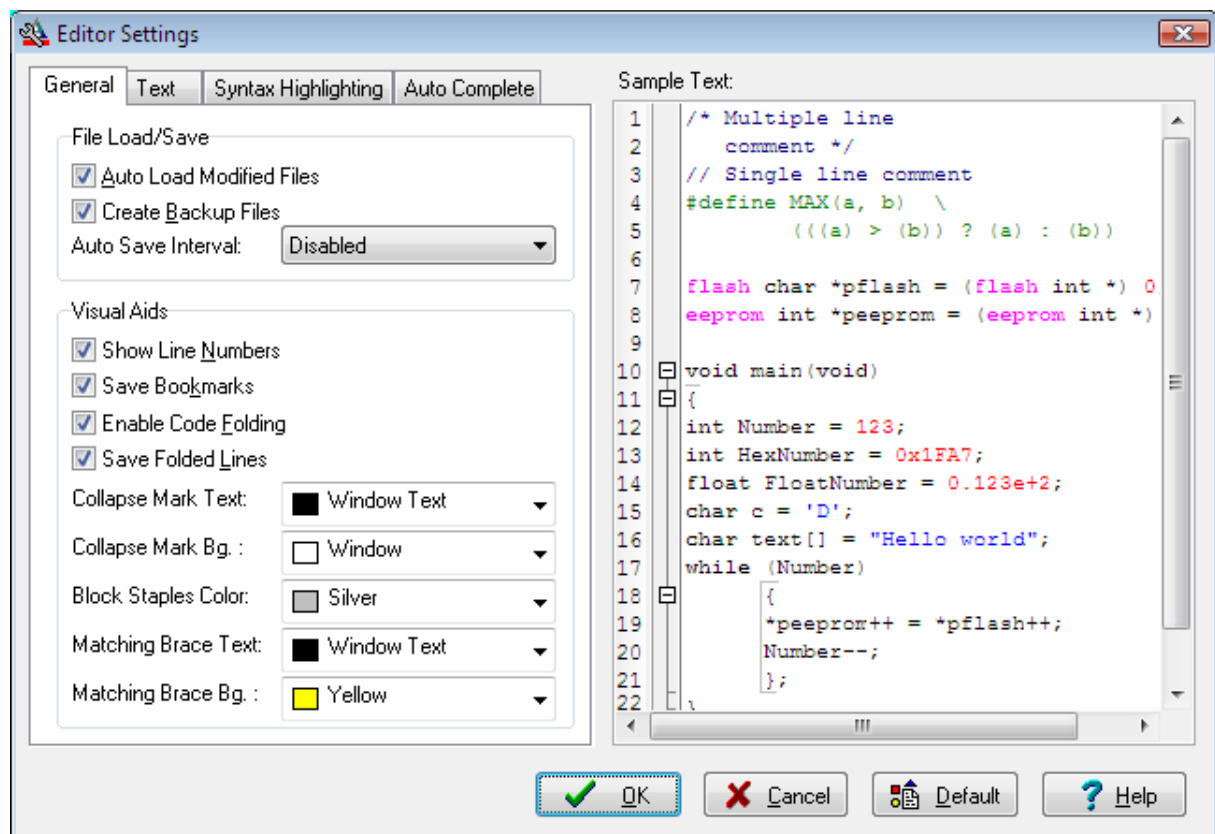

- **File Load/Save** settings;
- **Visual Aids** settings.

The **File Load/Save** settings allow for the following options to be set:

- **Auto Load Modified Files** enables or disables the automatic reloading, in the CodeVisionAVR Editor, of source files that were externally modified by some other program (another editor for example). If this option is disabled, the user will be prompted before the modified file will be reloaded in the Editor.
- **Create Backup Files** enables or disables the creation of backup copies of the files modified in the Editor. Backup copies will have the ~ character appended to their extension.
- **Auto Save Interval** specifies at which time interval all the modified source files will be automatically saved by the Editor.

CodeVisionAVR

The **Visual Aids** settings allow for the following options to be set:

- **Show Line Numbers** enables or disables the displaying of line numbers on the gutter located on the left side of the Editor windows;
- **Save Bookmarks** enables or disables saving the bookmarks set in each edited source file;
- **Enable Code Folding** enables or disables displaying of staples on the left side of code blocks delimited by the { } characters. If this option is enabled, block collapse/expansion marks will be also displayed on the gutter located on the left side of the Editor window.
- **Save Folded Lines** enables or disables saving the state of the folded blocks of lines for each edited source file;
- **Collapse Mark Text** specifies the text foreground color of the collapse marks;
- **Collapse Mark Bg.** specifies the text background color of the collapse marks;
- **Block Staples Color** specifies the foreground color of the folding block staples. The background color of the staples will be the same as the **Default Background Color** of the Editor window.
- **Matching Brace Text** specifies the text foreground color of the matching braces, which are automatically highlighted by the Editor when the user places the cursor before them;
- **Matching Brace Bg.** specifies the text background color of the highlighted matching braces.

2.5.3.2 Editor Text Settings

The following Editor settings can be established by clicking on the **Text** tab:

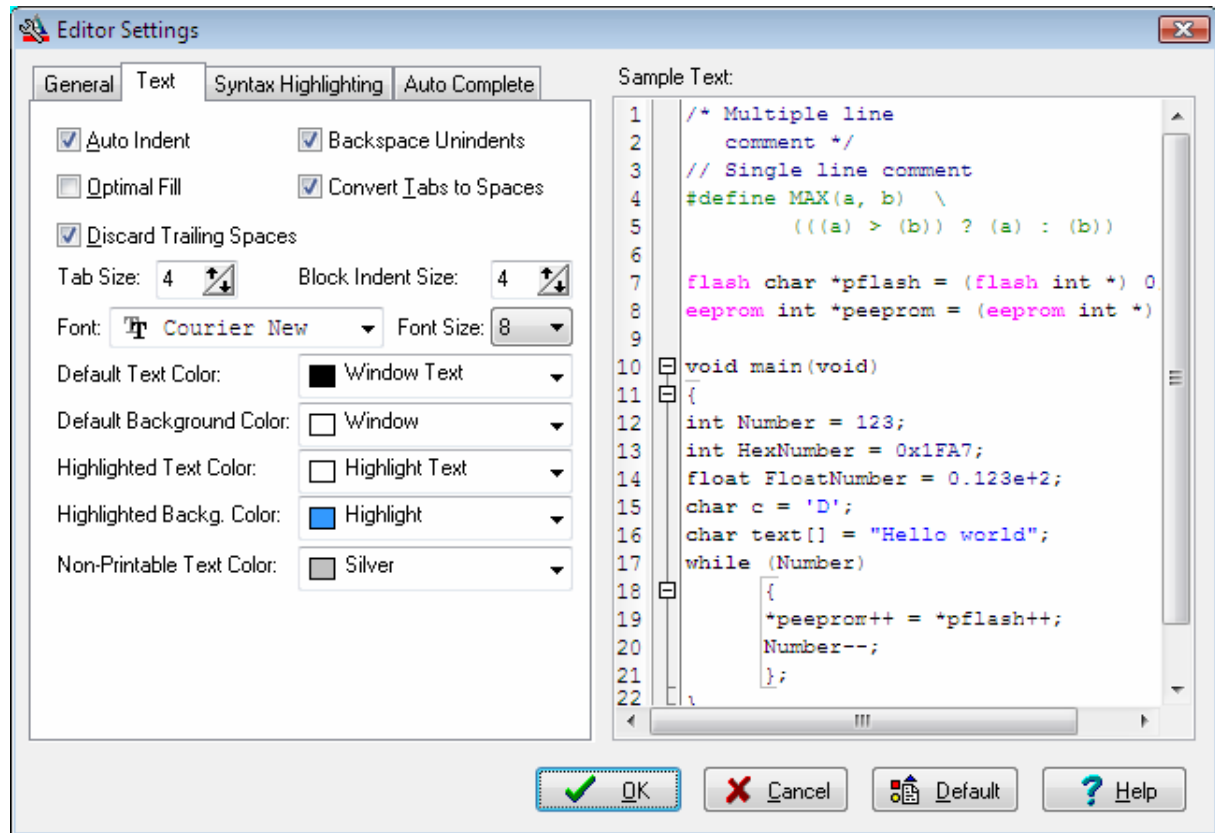

- **Auto Indent** enables or disables text auto indenting during file editing;
- **Backspace Unindents** when enabled, sets the Editor to align the insertion point to the previous indentation level (outdents it) when the user presses the Backspace key, if the cursor is on the first nonblank character of a line. If this option is disabled, pressing the Backspace key just deletes the character located on the left of the cursor.
- **Optimal Fill** enables or disables the beginning of every auto indented line with the minimum number of characters possible, using tabs and spaces as necessary;
- **Convert Tabs to Spaces** enables or disables the automatic replacement, while typing, of tab characters with the appropriate number of spaces, as specified by the **Tab Size** option;
- **Discard Trailing Spaces** enables or disables the automatic deletion from the end of each line, of spaces that are not followed by text,
- **Tab Size** specifies the number of spaces the Editor cursor is moved when the user presses the Tab key;
- **Block Indent Size** specifies the number of spaces the Editor indents a marked block of text;
- **Font** specifies the font type used by the Editor!;
- **Font Size** specifies the font size used by the Editor!;
- **Default Text Color** specifies the foreground color of the default (normal) text in the Editor and Terminal windows;
- **Default Background Color** specifies the background color of the default (normal) text in the Editor and Terminal windows;
- **Highlighted Text Color** specifies the foreground color of the text highlighted by the user in the Editor window;
- **Highlighted Background Color** specifies the background color of the text highlighted by the user in the Editor window;

CodeVisionAVR

- **Non-Printable Text Color** specifies the foreground color of the non-printable character markers displayed in the Editor window when the **View|Visible Non-Printable Characters** menu option is checked. The background color of the non-printable character markers will be the same as the **Default Background Color** of the Editor window.

2.5.3.3 Syntax Highlighting Settings

The following Editor settings can be established by clicking on the **Syntax Highlighting** tab:

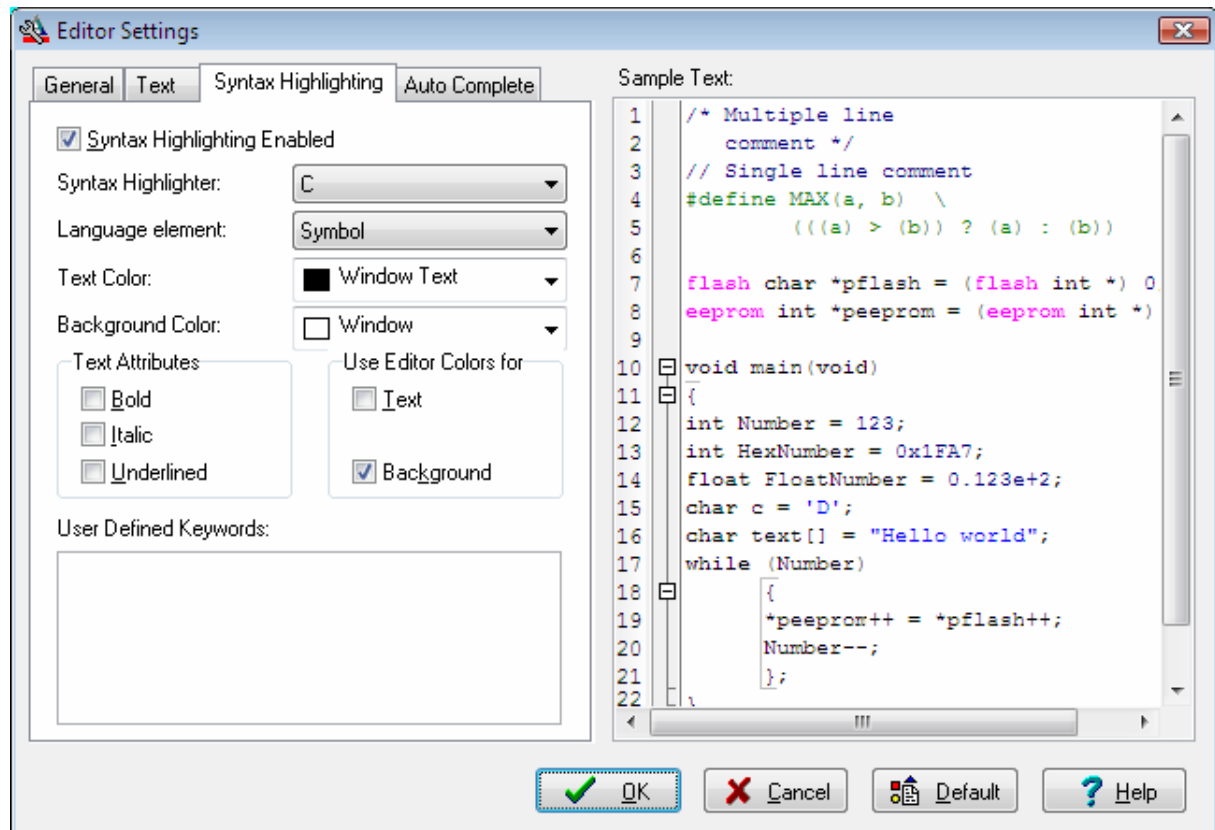

- **Syntax Highlighting Enabled** enables or disables source file syntax highlighting;
- **Syntax Highlighter** list box selects the programming language for which the syntax highlighting settings will be applied. The CodeVisionAVR Editor supports syntax highlighting for the C and Atmel AVR Assembler programming languages.
- **Language Element** list box selects the element for which the text colors and attributes will be set;
- **Text Color** specifies the text foreground color for the above selected **Language Element**;
- **Background Color** specifies the text background color for the above selected **Language Element**;
- **Text Attributes** specifies how the text is displayed for the above selected **Language Element**. Text attributes can be combined by appropriately checking the **Bold**, **Italic** and **Underlined** check boxes. The displayed font will be the one selected in the **Text|Font** settings.

The **Text**, respectively **Background**, check boxes from the **Use Editor Colors** group box, when checked will set the foreground, respectively background, text colors for the selected **Language Element** to the default ones specified in the **Text|Default Text Color**, respectively **Text|Default Background Color** settings.

CodeVisionAVR

The **User Defined Keywords** list can contain additional keywords for which syntax highlighting is required. Their text colors and attributes can be specified when selecting the **Language Element** as *User defined keyword*.

The results of the applied syntax highlighting settings can be viewed in the **Sample Text** portion of the window.

2.5.3.4 Auto Complete Settings

The following Editor settings can be established by clicking on the **Auto Complete** tab:

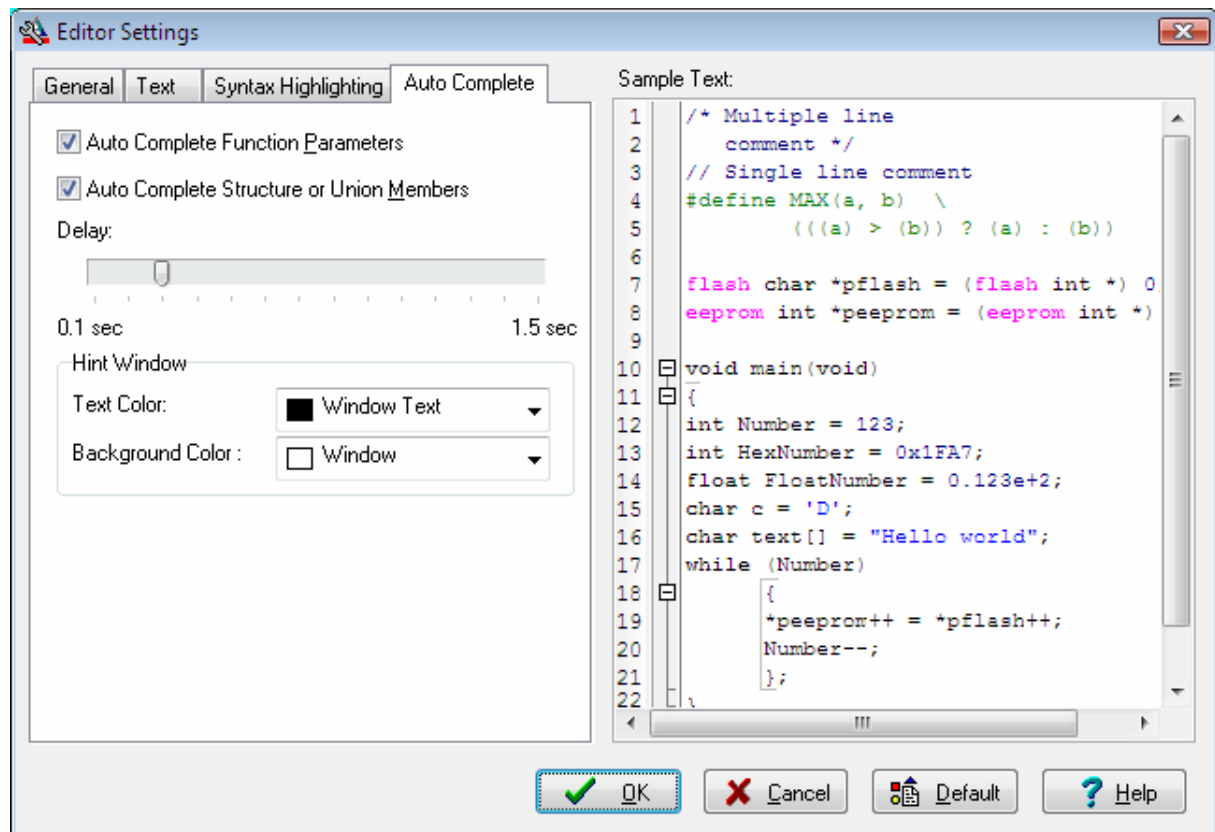

- **Auto Complete Function Parameters** enables or disables displaying a pop-up hint window with the function parameters declaration, after the user writes the function name followed by a '(' auto completion triggering character. The function parameter auto completing works only for the functions defined in the currently edited source file.
- **Auto Complete Structure or Union Members** enables or disables displaying a pop-up hint window with the structure/union members list, after the user writes the structure/union or pointer to structure/union name followed by the '.' or '->' auto completion triggering characters. The structure or union members auto completion works only for global structures/unions defined in the currently edited source file and after a **Project|Compile** or **Project|Build** was performed.

The **Delay** slider specifies the time delay that must elapse between entering the auto completion triggering characters and the displaying of the pop-up hint window. If the user writes any other character before this time delay, no pop-up hint window will show.

The **Hint Window** group box allows setting the **Text** and **Background Colors** of the auto complete pop-up hint window.

CodeVisionAVR

These colors will be also applied to the character grid pop-up hint window that is invoked using the **Edit|Insert Special Characters** menu, the **Insert Special Characters** right-click pop-up menu or by pressing the **Ctrl+.** keys.

2.5.4 Setting the Debugger Path

The CodeVisionAVR C Compiler is designed to work in conjunction with the Atmel AVR Studio debugger version 4.14 or later.

Before you can invoke the debugger, you must first specify its location and file name using the **Settings|Debugger** menu command.

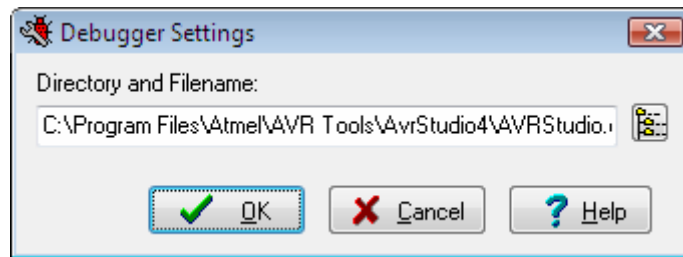

Pressing the  button opens a dialog window that allows selecting the debugger's directory and filename.

Changes can be saved, respectively canceled, using the **OK**, respectively **Cancel** buttons.

CodeVisionAVR

2.5.5 AVR Chip Programmer Setup

Using the **Settings|Programmer** menu command, you can select the type of the in-system programmer that is used, and the computer's port to which the programmer is connected. The current version of CodeVisionAVR supports the following in-system programmers:

- Kanda Systems STK200+ and STK300
- Atmel STK500 and AVRISP (serial connection)
- Atmel AVRISP MkII (USB connection)
- Atmel AVR Dragon (USB connection)
- Atmel JTAGICE MkII (USB connection)
- Atmel AVRProg (AVR910 application note)
- Dontronics DT006
- Vogel Elektronik VTEC-ISP
- Futurlec JRAVR
- MicroTronics ATCPU and Mega2000

The STK200+, STK300, DT006, VTEC-ISP, JRAVR, ATCPU and Mega2000 in-system programmers use the parallel printer port.

The following choices are available through the **Printer Port** radio group box:

- LPT1, at base address 378h;
- LPT2, at base address 278h;
- LPT3, at base address 3BCh.

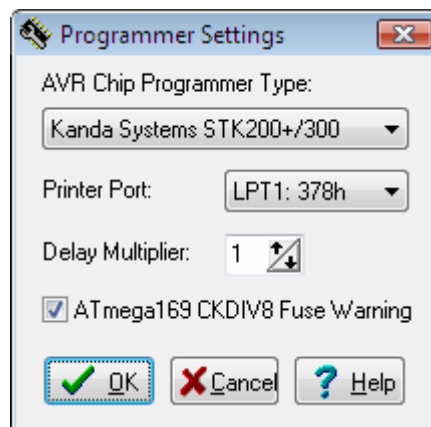

The **Delay Multiplier** value can be increased in case of programming problems on very fast machines. Of course this will increase overall programming time.

The **Atmega169 CKDIV8 Fuse Warning** check box, if checked, will enable the generation of a warning that further low voltage serial programming will be impossible for the *Atmega169 Engineering Samples*, if the CKDIV8 fuse will be programmed to 0. For usual Atmega169 chips this check box must be left unchecked.

CodeVisionAVR

The STK500, AVRISP and AVRProg programmers use the RS232C serial communication port, which can be specified using the **Communication Port** list box.

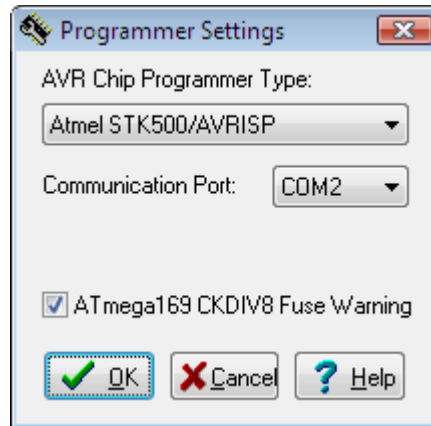

The Atmel AVRISP MkII, AVR Dragon and JTAGICE MkII use the USB connection for communication with the PC.

Usage of this programmer requires the Atmel's AVR Studio V4.14 or later software to be installed on the PC.

The Atmel AVR Dragon and JTAGICE MkII can use two programming modes:

- JTAG
- ISP

These can be selected using the **Programming Mode** list box:

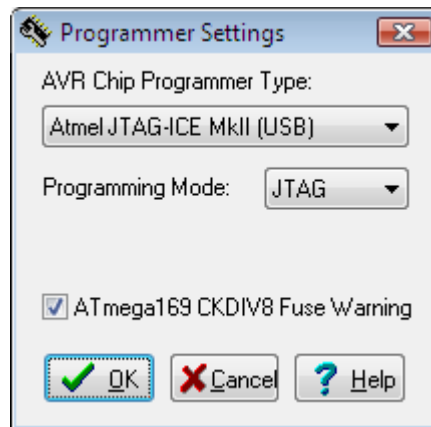

Changes can be saved, respectively canceled, using the **OK**, respectively **Cancel** buttons.

2.5.6 Serial Communication Terminal Setup

The serial communication **Terminal** is configured using the **Settings|Terminal** menu command.

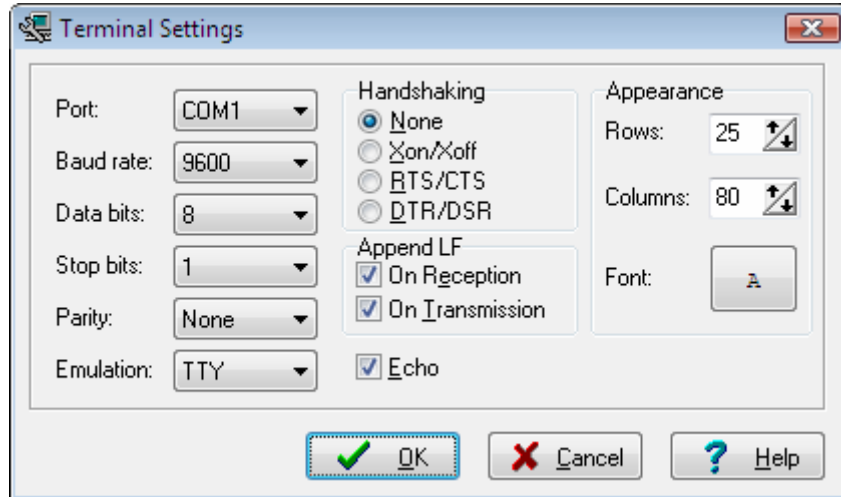

In the **Terminal Settings** window you can select the:

- computer's communication port used by the Terminal: COM1 to COM6;
- Baud rate used for communication: 110 to 115200;
- number of data bits used in reception and transmission: 5 to 8;
- number of stop bits used in reception and transmission: 1, 1.5 or 2;
- parity used in reception and transmission: None, Odd, Even, Mark or Space;
- type of emulated terminal: TTY, VT52 or VT100;
- type of handshaking used in communication: None, Hardware (CTS or DTR) or Software (XON/XOFF);
- possibility to append LF characters after CR characters on reception and transmission;
- enabling or disabling the echoing of the transmitted characters
- number of character **Rows** and **Columns** in the Terminal window
- **Font** type used for displaying characters in the Terminal window.

Changes can be saved, respectively canceled, using the **OK**, respectively **Cancel** buttons.

CodeVisionAVR

2.6 Accessing the Help

The CodeVisionAVR help system is accessed by invoking the **Help|Help** menu command or by pressing the  toolbar button.

2.7 Transferring or Deactivating the License

The CodeVisionAVR license is locked to the hardware of the PC on which the software is installed. After CodeVisionAVR is installed for the first time on a PC, it displays a computer dependant **Serial Number**, which must be sent by e-mail to HP InfoTech in order to receive an **Activation Code**, needed to unlock the license.

The **Activation Code** contains computer specific information, but also additional information about the license type and update/technical support validity period.

In case the user wishes to transfer his license to another computer, upgrade his license type or update/technical support validity period, he needs to use the **Help|Transfer/Deactivate License** menu.

Once this menu option is selected, the following dialog window will be displayed:

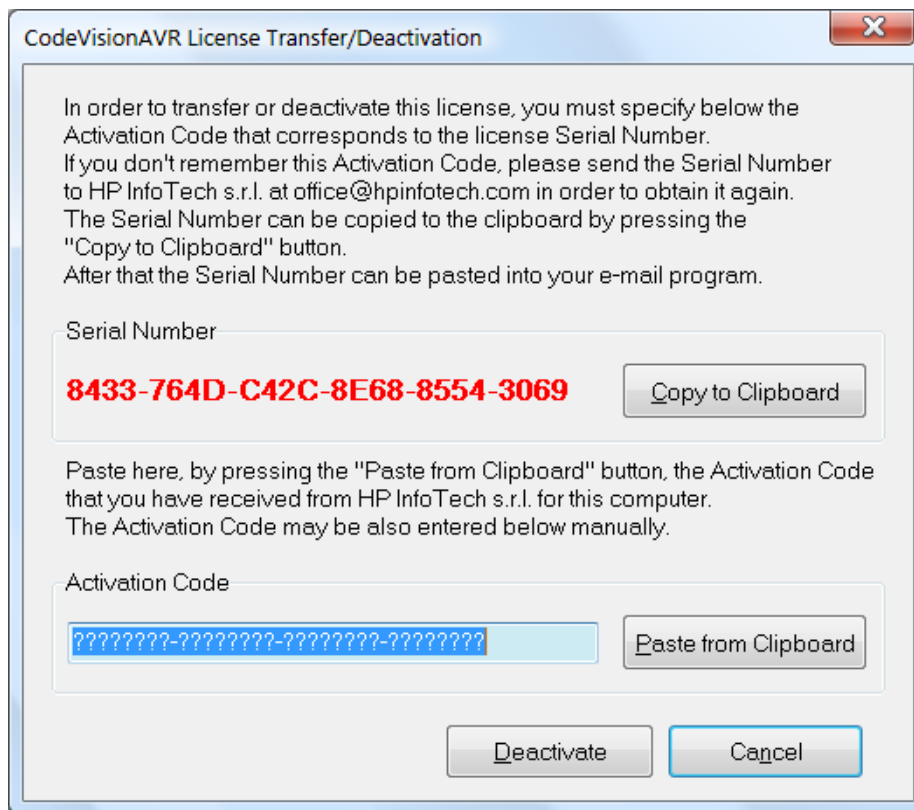

The **Serial Number** displayed in the dialog, is the current one for the computer on which CodeVisionAVR is installed.

If the user needs to write this **Serial Number** in an e-mail that must be sent to technical support, it can be copied to the clipboard using the **Copy to Clipboard** button and then pasted from the clipboard in the e-mail program.

In order to deactivate the license, the user must enter the **Activation Code** that was supplied by HP InfoTech when the license was initially activated.

This is necessary in order to prevent accidental license deactivation by unauthorized persons.

CodeVisionAVR

If the **Activation Code** was copied to the clipboard from the e-mail program, it may be pasted in the dialog using the **Paste from Clipboard** button.

Once the correct **Activation Code** was entered, pressing the **Deactivate** button will deactivate the license on the current computer.

On successful license deactivation a message containing the **License Removal Code** will be displayed:

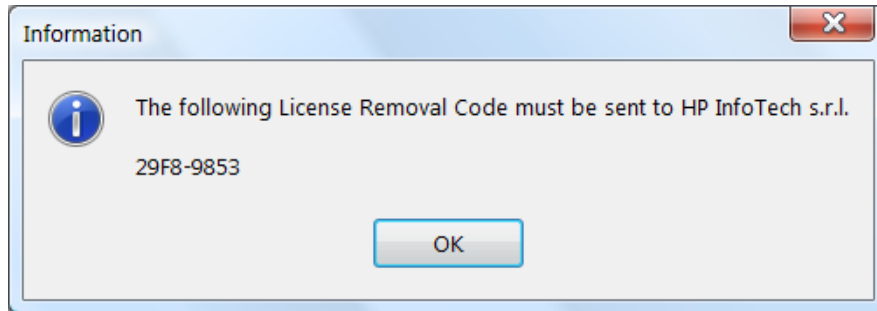

The **License Removal Code** must be sent by e-mail to HP InfoTech in order to confirm that the license was indeed deactivated, and that a new **Activation Code** may be sent to the user for a CodeVisionAVR installation on another computer or for a license on the same computer, but with updated characteristics.

If the entered **Activation Code** is not correct, the license is not deactivated, the **License Removal Code** is not displayed and the application just closes.

In such situation, the user must contact HP InfoTech for technical support.

2.8 Connecting to HP InfoTech's Web Site

The **Help|HP InfoTech on the Web** menu command or the  toolbar button opens the default web browser and connects to HP InfoTech's web site <http://www.hpinfotech.com>

2.9 Quitting the CodeVisionAVR IDE

To quit working with the CodeVisionAVR IDE you must select the **File|Exit** menu command.

If some source files were modified and were not saved yet, you will be prompted if you want to do that.

3. CodeVisionAVR C Compiler Reference

This section describes the general syntax rules for the CodeVisionAVR C compiler. Only specific aspects regarding the implementation of the C language by this compiler are exposed. This help is not intended to teach you the C language; you can use any good programming book to do that.

You must also consult the appropriate AVR data sheets from Atmel.

3.1 The C Preprocessor

The C Preprocessor directives allows you to:

- include text from other files, such as header files containing library and user function prototypes
- define macros that reduce programming effort and improve the legibility of the source code
- set up conditional compilation for debugging purposes and to improve program portability
- issue compiler specific directives

The Preprocessor output is saved in a text file with the same name as the source, but with the `.i` extension.

The **#include** directive may be used to include another file in your source.

You may nest as many as 300 **#include** files.

Example:

```
/* File will be looked for in the /inc directory of the compiler. */
#include <file_name>
```

or

```
/* File will be looked for in the current project directory.
   If it's not located there, then it will be included from
   the /inc directory of the compiler. */
#include "file_name"
```

The **#define** directive may be used to define a macro.

Example:

```
#define ALFA 0xff
```

This statement defines the symbol 'ALFA' to the value 0xff.

The C preprocessor will replace 'ALFA' with 0xff in the source text before compiling.

Macros can also have parameters. The preprocessor will replace the macro with its expansion and the formal parameters with the real ones.

Example:

```
#define SUM(a,b) a+b
/* the following code sequence will be replaced with int i=2+3; */
int i=SUM(2,3);
```

CodeVisionAVR

When defining macros you can use the **#** operator to convert the macro parameter to a character string.

Example:

```
#define PRINT_MESSAGE(t)  printf(#t)

/* ..... */
/* the following code sequence will be replaced with printf("Hello"); */
PRINT_MESSAGE>Hello);
```

Two parameters can be concatenated using the **##** operator.

Example:

```
#define ALFA(a,b) a ## b

/* the following code sequence will be replaced with char xy=1; */
char ALFA(x,y)=1;
```

A macro definition can be extended to a new line by using ****.

Example:

```
#define MESSAGE "This is a very \
long text..."
```

A macro can be undefined using the **#undef** directive.

Example:

```
#undef ALFA
```

The **#ifdef**, **#ifndef**, **#else** and **#endif** directives may be used for conditional compilation.

The syntax is:

```
#ifdef macro_name
[set of statements 1]
#else
[set of statements 2]
#endif
```

If 'alfa' is a defined macro name, then the **#ifdef** expression evaluates to true and the set of statements 1 will be compiled.

Otherwise the set of statements 2 will be compiled.

The **#else** and set of statements 2 are optional.

If 'alfa' is not defined, the **#ifndef** expression evaluates to true.

The rest of the syntax is the same as that for **#ifdef**.

The **#if**, **#elif**, **#else** and **#endif** directives may be also used for conditional compilation.

```
#if expression1
[set of statements 1]
#elif expression2
[set of statements 2]
#else
[set of statements 3]
#endif
```

If **expression1** evaluates to true, the set of statements 1 will be compiled.

If **expression2** evaluates to true, the set of statements 2 will be compiled.

Otherwise the set of statements 3 will be compiled.

The **#else** and set of statements 3 are optional.

CodeVisionAVR

There are the following predefined macros:

__CODEVISIONAVR__ the version and revision of the compiler represented as an integer, example for V2.04.0 this will be 2040

__STDC__ equals to 1

__LINE__ the current line number of the compiled file

__FILE__ the current compiled file

__TIME__ the current time in *hh:mm:ss* format

__UNIX_TIME__ unsigned long that represents the number of seconds elapsed since midnight UTC of 1 January 1970, not counting leap seconds

__DATE__ the current date in *mmm dd yyyy* format

__BUILD__ the build number

__CHIP_ATXXXXX where ATXXXXX is the chip type, in uppercase letters, specified in the **Project|Configure|C Compiler|Code Generation|Chip** option

__MCU_CLOCK_FREQUENCY__ the AVR clock frequency specified in the **Project|Configure|C Compiler|Code Generation|Clock** option, expressed as an unsigned long integer in Hz

__MODEL_TINY__ if the program is compiled using the TINY memory model

__MODEL_SMALL__ if the program is compiled using the SMALL memory model

__MODEL_MEDIUM__ if the program is compiled using the MEDIUM memory model

__MODEL_LARGE__ if the program is compiled using the LARGE memory model

__OPTIMIZE_SIZE__ if the program is compiled with optimization for size (**Project|Configure|C Compiler|Code Generation|Optimize for: Size** option or **#pragma optimize+**)

__OPTIMIZE_SPEED__ if the program is compiled with optimization for speed (**Project|Configure|C Compiler|Code Generation|Optimize for: Speed** option or **#pragma optimize-**)

__WARNINGS_ON__ if the warnings are enabled by the **Project|Configure|C Compiler|Messages|Enable Warnings** option or **#pragma warn+**

__WARNINGS_OFF__ if the warnings are disabled by the **Project|Configure|C Compiler|Messages|Enable Warnings** option or **#pragma warn-**

__PROMOTE_CHAR_TO_INT_ON__ if the automatic ANSI char to int type promotion is enabled by the **Project|Configure|C Compiler|Code Generation|Promote char to int** option or **#pragma promotechar+**

__PROMOTE_CHAR_TO_INT_OFF__ if the automatic ANSI char to int type promotion is disabled by the **Project|Configure|C Compiler|Code Generation|Promote char to int** option or **#pragma promotechar-**

__AVR8L_CORE__ signals that the program is compiled using the reduced core instruction set, used in chips like ATtiny10. No ADIW, SBIB, LDD and STD instructions are generated in this case.

__ENHANCED_CORE__ if the program is compiled using the enhanced core instructions available in the new ATmega chips

__IO_BITS_DEFINITIONS__ if the **Project|Configure|C Compiler|Code Generation|Preprocessor|Include I/O Registers Bits Definitions** option is enabled

__DSTACK_SIZE__ the data stack size specified in the **Project|Configure|C Compiler|Code Generation|Data Stack Size** option

__HEAP_START__ the heap starting address

__HEAP_SIZE__ the heap size specified in the **Project|Configure|C Compiler|Code Generation|Heap Size** option

__UNSIGNED_CHAR__ if the **Project|Configure|C Compiler|Code Generation|char is unsigned** compiler option is enabled or **#pragma uchar+** is used

__8BIT_ENUMS__ if the **Project|Configure|C Compiler|Code Generation|8 bit enums** compiler option is enabled or **#pragma 8bit_enums+** is used

__ATXMEGA_USART__ specifies which ATxmega chip USART is used by the **getchar** and **putchar** Standard C Input/Output Functions

__ATXMEGA_SPI__ specifies which ATxmega chip SPI controller is used by the SPI Functions

__ATXMEGA_SPI_PORT__ specifies which ATxmega chip I/O port is used by the SPI controller.

CodeVisionAVR

The **#line** directive can be used to modify the predefined **__LINE__** and **__FILE__** macros.
The syntax is:

```
#line integer_constant ["file_name"]
```

Example:

```
/* This will set __LINE__ to 50 and  
   __FILE__ to "file2.c" */  
#line 50 "file2.c"  
  
/* This will set __LINE__ to 100 */  
#line 100
```

The **#error** directive can be used to stop compilation and display an error message.
The syntax is:

```
#error error_message
```

Example:

```
#error This is an error!
```

The **#warning** directive can be used to display a warning message.
The syntax is:

```
#warning warning_message
```

Example:

```
#warning This is a warning!
```

The **#message** directive can be used to display a message dialog window in the CodeVisionAVR IDE.
The syntax is:

```
#message general_message
```

Example:

```
#message Hello world
```

3.2 Comments

The character string `/*` marks the beginning of a comment.
The end of the comment is marked with `*/`.

Example:

```
/* This is a comment */
/* This is a
   multiple line comment */
```

One-line comments may be also defined by using the string `//`.

Example:

```
// This is also a comment
```

Nested comments are not allowed.

3.3 Reserved Keywords

Following is a list of keywords reserved by the compiler. These can not be used as identifier names.

```
__eeprom  
__flash  
__interrupt  
__task  
_Bool  
break  
bit  
bool  
case  
char  
const  
continue  
default  
defined  
do  
double  
eeprom  
else  
enum  
extern  
flash  
float  
for  
goto  
if  
inline  
int  
interrupt  
long  
register  
return  
short  
signed  
sizeof  
sfrb  
sfrw  
static  
struct  
switch  
typedef  
union  
unsigned  
void  
volatile  
while
```

3.4 Identifiers

An identifier is the name you give to a variable, function, label or other object.

An identifier can contain letters (A...Z, a...z) and digits (0...9), as well as the underscore character (_). However an identifier can only start with a letter or an underscore.

Case is significant; i.e. **variable1** is not the same as **Variable1**.

Identifiers can have up to 64 characters.

3.5 Data Types

The following table lists all the data types supported by the CodeVisionAVR C compiler, their range of possible values and their size:

Type	Size (Bits)	Range
bit	1	0 , 1
bool, _Bool	8	0 , 1
char	8	-128 to 127
unsigned char	8	0 to 255
signed char	8	-128 to 127
int	16	-32768 to 32767
short int	16	-32768 to 32767
unsigned int	16	0 to 65535
signed int	16	-32768 to 32767
long int	32	-2147483648 to 2147483647
unsigned long int	32	0 to 4294967295
signed long int	32	-2147483648 to 2147483647
float	32	$\pm 1.175e-38$ to $\pm 3.402e38$
double	32	$\pm 1.175e-38$ to $\pm 3.402e38$

The **bit** data type is not allowed as the type of an array element or structure/union member.

If the **Project|Configure|C Compiler|Code Generation|char is unsigned** option is checked or **#pragma uchar+** is used, then **char** has by default the range 0..255.

3.6 Constants

Integer or long integer constants may be written in decimal form (e.g. 1234), in binary form with **0b** prefix (e.g. 0b101001), in hexadecimal form with **0x** prefix (e.g. 0xff) or in octal form with **0**-prefix (e.g. 0777).

Unsigned integer constants may have the suffix **U** (e.g. 10000U).

Long integer constants may have the suffix **L** (e.g. 99L).

Unsigned long integer constants may have the suffix **UL** (e.g. 99UL).

Floating point constants may have the suffix **F** (e.g. 1.234F).

Character constants must be enclosed in single quotation marks. E.g. 'a'.

Literal string constants must be enclosed in double quotation marks. E.g. "Hello world".

Constant expressions are automatically evaluated during compilation.

Program constants can be declared as global (accessible to all the functions in the program) or local (accessible only inside the function they are declared).

The constant declarations syntax is similar to that of variables, but preceded by the **const** keyword:

```
const <type definition> <identifier> = constant expression;
```

Example:

```
/* Global constants declaration */
const char char_constant='a';
const int b=1234+5;
const long long_int_constant1=99L;
const long long_int_constant2=0x10000000;
const float pi=3.14;

void main(void) {
/* Local constants declaration */
const long f=22222222;
const float x=1.5;

}
```

Constants can be grouped in arrays, which can have up to 64 dimensions.

The first element of an array has always the index 0.

Example:

```
const char string_constant2[]="This is a string constant";
const int abc[3]={1,2,3};
/* The first two elements will be 1 and 2,
   the rest will be 0 */
const int integer_array2[10]={1,2};
/* multidimensional array */
const int multidim_array[2][3]={{1,2,3},{4,5,6}};
```

If the **Project|Configure|C Compiler|Code Generation|Store Global Constants in FLASH Memory** option is enabled, global constants that were declared using the **const** keyword will be placed by the compiler in FLASH memory.

If the above option is not enabled, global constants declared using the **const** keyword will be located in RAM memory.

Local constants will be always placed in RAM memory.

CodeVisionAVR

The **flash** or **__flash** keywords can be used to specify that a constant must be placed in FLASH memory, no matter what is the state of the **Store Global Constants in FLASH Memory** option:

```
flash <type definition> <identifier> = constant expression;
__flash <type definition> <identifier> = constant expression;
```

Example:

```
flash int   integer_constant=1234+5;
flash char  char_constant='a';
flash long  long_int_constant1=99L;
flash long  long_int_constant2=0x10000000;
flash int   integer_array1[]={1,2,3};
flash char  string_constant1[]="This is a string constant located in FLASH";
```

The constant literal char strings, enclosed in double quotation marks, that are passed as function arguments, are stored in the memory type pointed by the pointer used as function parameter.

Example:

```
/* This function displays a string located in RAM. */
void display_ram(char *s) {
/* ..... */
}

/* This function displays a string located in FLASH. */
void display_flash(flash char *s) {
/* ..... */
}

/* This function displays a string located in EEPROM. */
void display_eeprom(eeprom char *s) {
/* ..... */
}

void main(void) {
/* The literal string "Hello world" will be placed
   by the compiler in FLASH memory and copied at program
   startup to RAM, so it can be accessed by the pointer
   to RAM used as function parameter.
   The code efficiency is low, because both FLASH and
   RAM memories are used for the string storage. */
display_ram("Hello world");

/* The literal string "Hello world" will be placed
   by the compiler in FLASH memory only, good code
   efficiency beeing achieved. */
display_flash("Hello world");

/* The literal string "Hello world" will be placed
   by the compiler in EEPROM memory only.
   The code efficiency is very good because no
   FLASH memory will be allocated for the string. */
display_eeprom("Hello world");

while(1);
}
```

3.7 Variables

Program variables can be global (accessible to all the functions in the program) or local (accessible only inside the function they are declared).

If not specifically initialized, the global variables are automatically set to 0 at program startup.

The local variables are not automatically initialized on function call.

The syntax is:

```
[<memory attribute>] [<storage modifier>] <type definition> <identifier>
                                                                [= constant expression];
```

Example:

```
/* Global variables declaration */
char a;
int b;
/* and initialization */
long c=1111111;

void main(void) {
/* Local variables declaration */
char d;
int e;
/* and initialization */
long f=22222222;
}
```

Variables can be grouped in arrays, which can have up to 64 dimensions.

The first element of an array has always the index 0.

If not specifically initialized, the elements of global variable arrays are automatically set to 0 at program startup.

Example:

```
/* All the elements of the array will be 0 */
int global_array1[32];

/* Array is automatically initialized */
int global_array2[]={1,2,3};
int global_array3[4]={1,2,3,4};
char global_array4[]="This is a string";

/* Only the first 3 elements of the array are
   initialized, the rest 29 will be 0 */
int global_array5[32]={1,2,3};

/* Multidimensional array */
int multidim_array[2][3]={{1,2,3},{4,5,6}};

void main(void) {
/* local array declaration */
int local_array1[10];

/* local array declaration and initialization */
int local_array2[3]={11,22,33};
char local_array3[7]="Hello";
}
```

CodeVisionAVR

Local variables that must conserve their values during different calls to a function must be declared as **static**. Example:

```
int alfa(void) {
/* declare and initialize the static variable */
static int n=1;
return n++;
}

void main(void) {
int i;

/* the function will return the value 1 */
i=alfa();

/* the function will return the value 2 */
i=alfa();
}
```

If not specifically initialized, **static** variables are automatically set to 0 at program startup.

Variables that are declared in other files must be preceded by the **extern** keyword.

Example:

```
extern int xyz;

/* now include the file which contains
the variable xyz definition */
#include <file_xyz.h>
```

To instruct the compiler to allocate a variable to registers, the **register** modifier must be used.

Example:

```
register int abc;
```

The compiler may automatically allocate a variable to registers, even if this modifier is not used.

The **volatile** modifier must be used to warn the compiler that it may be subject to outside change during evaluation.

Example:

```
volatile int abc;
```

Variables declared as volatile will not be allocated to registers.

All the global variables, not allocated to registers, are stored in the **Global Variables** area of RAM. All the local variables, not allocated to registers, are stored in dynamically allocated space in the **Data Stack** area of RAM.

If a global variable declaration is preceded by the **eprom** or **__eprom** memory attribute, the variable will be located in EEPROM.

Example:

```
eprom float xyz=12.9;
__eprom int w[5]={1,2,3,4,5};
```

3.7.1 Specifying the RAM and EEPROM Storage Address for Global Variables

Global variables can be stored at specific RAM and EEPROM locations at design-time using the @ operator.

Example:

```
/* the integer variable "a" is stored
   in RAM at address 80h */
int a @0x80;
```

```
/* the structure "alfa" is stored
   in RAM at address 90h */
struct s1 {
    int a;
    char c;
} alfa @0x90;
```

```
/* the float variable "b" is stored
   in EEPROM at address 10h */
eeprom float b @0x10;
```

```
/* the structure "beta" is stored
   in EEPROM at address 20h */
eeprom struct s2 {
    int i;
    long j;
} beta @0x20;
```

The following procedure must be used if a global variable, placed at a specific address using the @ operator, must be initialized during declaration:

```
/* the variable will be stored in RAM at address 0x182 */
float pi @0x182;
/* and it will be initialized with the value 3.14 */
float pi=3.14;
```

```
/* the variable will be stored in EEPROM at address 0x10 */
eeprom int abc @0x10;
/* and it will be initialized with the value 123 */
eeprom int abc=123;
```

3.7.2 Bit Variables

The global bit variables located in the GPIOR register(s) and R2 to R14 memory space. These variables are declared using the **bit** keyword. The syntax is:

```
bit <identifier>;
```

Example:

```
/* declaration and initialization for an ATtiny2313 chip
   which has GPIOR0, GPIOR1 and GPIOR2 registers */
bit alfa=1; /* bit0 of GPIOR0 */
bit beta; /* bit1 of GPIOR0 */

void main(void)
{
if (alfa) beta=!beta;

/* ..... */
}
```

Memory allocation for the global bit variables is done, in the order of declaration, starting with bit 0 of GPIOR0, then bit 1 of GPIOR0 and so on, in ascending order. After all the GPIOR registers are allocated, further bit variables are allocated in R2 up to R14. If the chip does not have GPIOR registers, the allocation begins directly from register R2.

The size of the global bit variables allocated to the program can be specified in the **Project|Configure|C Compiler|Code Generation|Bit Variables Size** list box. This size should be as low as possible, in order to free registers for allocation to other global variables. If not specifically initialized, the global bit variables are automatically set to 0 at program startup.

The compiler allows also to declare up to 8 local bit variables which will be allocated in register R15. Example:

```
void main(void)
{
bit alfa; /* bit 0 of R15 */
bit beta; /* bit 1 of R15 */
/* ..... */
}
```

In expression evaluation bit variables are automatically promoted to **unsigned char**.

As there is no support for the bit data type in the COFF object file format, the CodeVisionAVR compiler generates debugging information for the whole register where a bit variable is located. Therefore when watching bit variables in the AVR Studio debugger, the value of the register is displayed instead of a single bit from it.

However it is quite simple to establish the value of the bit variable based on the register bit number allocated for it, which is displayed in the **Code Information** tab of the CodeVisionAVR IDE, and the register value displayed in hexadecimal in AVR Studio's **Watch** window.

3.7.3 Allocation of Variables to Registers

In order to fully take advantage of the AVR architecture and instruction set, the compiler allocates some of the program variables to chip registers.

The registers from R2 up to R14 can be allocated for global **bit** variables.

The register R15 can be allocated to local **bit** variables.

You may specify how many registers in the R2 to R14 range are allocated for global **bit** variables using the **Project|Configure|C Compiler|Code Generation|Bit Variables Size** list box. This value must be as low as required by the program.

If the **Project|Configure|C Compiler|Code Generation|Automatic Global Register Allocation** option is checked or the **#pragma regalloc+** compiler directive is used, the rest of registers in the R2 to R14 range, that aren't used for global **bit** variables, are allocated to **char** and **int** global variables and global pointers.

If the **Project|Configure|C Compiler|Code Generation|Smart Register Allocation** option is checked, the allocation of registers R2 to R14 (not used for bit variables) is performed in such a way that 16bit variables will be preferably located in even register pairs, thus favouring the usage of the enhanced core MOVW instruction for their access.

Otherwise the allocation is performed in order of variable declaration until the R14 register is allocated.

If the automatic register allocation is disabled, you can use the **register** keyword to specify which global variable to be allocated to registers.

Example:

```
/* disable automatic register allocation */
#pragma regalloc-
/* allocate the variable 'alfa' to a register */
register int alfa;
/* allocate the variable 'beta' to the register pair R10, R11 */
register int beta @10;
```

Local **char**, **int** and **pointer** local variables are allocated to registers R16 to R21.

If the **Project|Configure|C Compiler|Code Generation|Smart Register Allocation** option is checked, the allocation of these registers for local variables is performed in such a way that 16bit variables will be preferably located in even register pairs, thus favouring the usage of the enhanced core MOVW instruction for their access.

Otherwise the local variables are automatically allocated to registers in the order of declaration.

The **Project|Configure|C Compiler|Code Generation|Smart Register Allocation** option should be disabled if the program was developed using CodeVisionAVR prior to V1.25.3 and it contains inline assembly code that accesses the variables located in registers R2 to R14 and R16 to R21.

3.7.4 Structures

Structures are user-defined collections of named members.

The structure members can be any of the supported data types, arrays of these data types or pointers to them.

Structures are defined using the **struct** reserved keyword.

The syntax is:

```
[<memory attribute>] struct [<structure tag-name>] {
    [<type> <variable-name>[,<variable-name>, ...]];
    [<type> [<bitfield-id>]:<width>[, [<bitfield-id>]:<width>, ...]];
    ...
} [<structure variables>;
```

Example:

```
/* Global structure located in RAM */
struct ram_structure {
    char a,b;
    int c;
    char d[30],e[10];
    char *pp;
} sr;

/* Global constant structure located in FLASH */
flash struct flash_structure {
    int a;
    char b[30], c[10];
} sf;

/* Global structure located in EEPROM */
eeprom struct eeprom_structure {
    char a;
    int b;
    char c[15];
} se;

void main(void) {
/* Local structure */
struct local_structure {
    char a;
    int b;
    long c;
} sl;

/* ..... */
}
```

The space allocated to the structure in memory is equal to sum of the sizes of all the members.

CodeVisionAVR

The same generic structure type can be declared in any memory type: RAM, FLASH or EEPROM:

```
/* Generic structure type */
struct my_structure {
    char a,b;
    int c;
    char d[30],e[10];
    char *pp;
};

/* Global structure located in RAM */
struct my_structure sr;

/* Global pointer located in RAM to the RAM located structure */
struct my_structure *ptrsr = &sr;

/* Global pointer located in FLASH to the RAM located structure */
struct my_structure * flash ptrfsr = &sr;

/* Global pointer located in EEPROM to the RAM located structure */
struct my_structure * eeprom ptrresr = &sr;

/* Global constant structure located in FLASH */
flash struct my_structure sf = {0,0,0,{0},{0},0};

/* Global pointer located in RAM to the FLASH located structure */
flash struct my_structure *ptrsf = &sf;

/* Global pointer located in FLASH to the FLASH located structure */
flash struct my_structure * flash ptrfsf = &sf;

/* Global pointer located in EEPROM to the FLASH located structure */
flash struct my_structure * eeprom ptresf = &sf;

/* Global constant structure located in EEPROM */
eeprom struct my_structure se;

/* Global pointer located in RAM to the EEPROM located structure */
eeprom struct my_structure *ptrse = &se;

/* Global pointer located in FLASH to the EEPROM located structure */
eeprom struct my_structure * flash ptrfse = &se;

/* Global pointer located in EEPROM to the EEPROM located structure */
eeprom struct my_structure * eeprom ptrese = &se;

void main(void) {
/* Local structure */
struct my_structure sl;
/* Local pointer to the RAM located global structure */
struct my_structure *ptrlsr = &sr;
/* Local pointer to the FLASH located global structure */
flash struct my_structure *ptrlsf = &sf;
/* Local pointer to the EEPROM located global structure */
eeprom struct my_structure *ptrlse = &se;

/* ..... */

}
```

CodeVisionAVR

Structures can be grouped in arrays.

Example how to initialize and access an global structure array stored in EEPROM:

```
/* Global structure array located in EEPROM */
eeprom struct eeprom_structure {
    char a;
    int b;
    char c[15];
    } se[2]={{'a',25,"Hello"},
            {'b',50,"world"}};

void main(void) {
char k1,k2,k3,k4;
int i1, i2;

/* define a pointer to the structure */
struct eeprom_structure eeprom *ep;

/* direct access to structure members */
k1=se[0].a;
i1=se[0].b;
k2=se[0].c[2];
k3=se[1].a;
i2=se[1].b;
k4=se[1].c[2];

/* same access to structure members using a pointer */
ep=&se; /* initialize the pointer with the structure address */
k1=ep->a;
i1=ep->b;
k2=ep->c[2];
++ep; /* increment the pointer */
k3=ep->a;
i2=ep->b;
k4=ep->c[2];
}
```

Because some AVR devices have a small amount of RAM, in order to keep the size of the **Data Stack** small, it is recommended not to pass structures as function parameters and use pointers for this purpose.

Example:

```
struct alpha {
    int a,b, c;
    } s={2,3};
/* define the function */
struct alpha *sum_struct(struct alpha *sp) {
/* member c=member a + member b */
sp->c=sp->a + sp->b;
/* return a pointer to the structure */
return sp;
}
void main(void) {
int i;
/* s->c=s->a + s->b */
/* i=s->c */
i=sum_struct(&s)->c;
}
```

CodeVisionAVR

Structure members can be also declared as bit fields, having a width from 1 to 32. Bit fields are allocated in the order of declaration starting from the least significant bit.

Example:

```
/* this structure will occupy 1 byte in RAM
   as the bit field data type is unsigned char */
struct alpha1 {
    unsigned char a:1; /* bit 0 */
    unsigned char b:4; /* bits 1..4 */
    unsigned char c:3; /* bits 5..7 */
};

/* this structure will occupy 2 bytes in RAM
   as the bit field data type is unsigned int */
struct alpha2 {
    unsigned int a:2; /* bits 0..1 */
    unsigned int b:8; /* bits 2..9 */
    unsigned int c:4; /* bits 10..13 */
                    /* bits 14..15 are not used */
};

/* this structure will occupy 4 bytes in RAM
   as the bit field data type is unsigned long */
struct alpha3 {
    unsigned long a:10; /* bits 0..9 */
    unsigned long b:8; /* bits 10..17 */
    unsigned long c:6; /* bits 18..23 */
                    /* bits 24..31 are not used */
};
```

3.7.5 Unions

Unions are user-defined collections of named members that share the same memory space. The union members can be any of the supported data types, arrays of these data types or pointers to them.

Unions are defined using the **union** reserved keyword.

The syntax is:

```
[<memory attribute>] [<storage modifier>] union [<union tag-name>] {
    [<type> <variable-name>[,<variable-name>, ...]];
    [<type> <bitfield-id>:<width>[,<bitfield-id>:<width>, ...]];
    ...
} [<union variables>;
```

The space allocated to the union in memory is equal to the size of the largest member.

Union members can be accessed in the same way as structure members. Example:

```
/* union declaration */
union alpha {
    unsigned char lsb;
    unsigned int  word;
} data;

void main(void) {
    unsigned char k;

    /* define a pointer to the union */
    union alpha *dp;

    /* direct access to union members */
    data.word=0x1234;
    k=data.lsb; /* get the LSB of 0x1234 */

    /* same access to union members using a pointer */
    dp=&data; /* initialize the pointer with the union address */
    dp->word=0x1234;
    k=dp->lsb; /* get the LSB of 0x1234 */
}
```

Because some AVR devices have a small amount of RAM, in order to keep the size of the **Data Stack** small, it is recommended not to pass unions as function parameters and use pointers for this purpose.

Example:

```
#include <stdio.h> /* printf */
union alpha {
    unsigned char lsb;
    unsigned int  word;
} data;

/* define the function */
unsigned char low(union alpha *up) {
    /* return the LSB of word */
    return up->lsb;
}

void main(void) {
    data.word=0x1234;
    printf("the LSB of %x is %2x", data.word, low(&data));
}
```

CodeVisionAVR

Union members can be also declared as bit fields, having a width from 1 to 32.
Bit fields are allocated in the order of declaration starting from the least significant bit.
Example:

```
/* this union will occupy 1 byte in RAM
   as the bit field data type is unsigned char */
union alpha1 {
    unsigned char a:1; /* bit 0 */
    unsigned char b:4; /* bits 0..3 */
    unsigned char c:3; /* bits 0..2 */
};

/* this union will occupy 2 bytes in RAM
   as the bit field data type is unsigned int */
union alpha2 {
    unsigned int a:2; /* bits 0..1 */
    unsigned int b:8; /* bits 0..7 */
    unsigned int c:4; /* bits 0..3 */
                    /* bits 8..15 are not used */
};

/* this union will occupy 4 bytes in RAM
   as the bit field data type is unsigned long */
union alpha3 {
    unsigned long a:10; /* bits 0..9 */
    unsigned long b:8; /* bits 0..7 */
    unsigned long c:6; /* bits 0..5 */
                    /* bits 10..31 are not used */
};
```

3.7.6 Enumerations

The enumeration data type can be used in order to provide mnemonic identifiers for a set of **char** or **int** values.

The **enum** keyword is used for this purpose.

The syntax is:

```
[<memory attribute>] [<storage modifier>] enum [<enum tag-name>] {  
    [<constant-name[=constant-initializer], constant-name, ...]>]  
    [<enum variables>];
```

Example:

```
/* The enumeration constants will be initialized as follows:  
   sunday=0 , monday=1 , tuesday=2 , ..., saturday=6 */  
enum days {  
    sunday, monday, tuesday, wednesday,  
    thursday, friday, saturday} days_of_week;  
  
/* The enumeration constants will be initialized as follows:  
   january=1 , february=2 , march=3 , ..., december=12 */  
enum months {  
    january=1, february, march, april, may, june,  
    july, august, september, october, november, december}  
    months_of_year;  
  
void main {  
/* the variable days_of_week is initialized with  
   the integer value 6 */  
days_of_week=saturday;  
}
```

Enumerations can be stored in RAM, EEPROM or FLASH.

The **eprom** or **__eprom** memory attributes must be used to specify enumeration storage in EEPROM.

Example:

```
eprom enum days {  
    sunday, monday, tuesday, wednesday,  
    thursday, friday, saturday} days_of_week;
```

The **flash** or **__flash** memory attributes must be used to specify enumeration storage in FLASH memory.

Example:

```
flash enum months {  
    january, february, march, april, may, june,  
    july, august, september, october, november,  
    december}  
    months_of_year;
```

It is recommended to treat enumerations as having 8 bit **char** data type, by checking the **8 bit enums** check box in **Project|Configure|CompilerCode Generation**. This will improve the size and execution speed of the compiled program.

3.8 Defining Data Types

User defined data types are declared using the **typedef** reserved keyword.
The syntax is:

```
typedef <type definition> <identifier>;
```

The symbol name <identifier> is assigned to <type definition>.

Examples:

```
/* type definitions */
typedef unsigned char byte;
typedef struct {
    int a;
    char b[5];
} struct_type;

/* variable declarations */
byte alfa;

/* structure stored in RAM */
struct_type struct1;

/* structure stored in FLASH */
flash struct_type struct2;

/* structure stored in EEPROM */
eeprom struct_type struct3;
```

3.9 Type Conversions

In an expression, if the two operands of a binary operator are of different types, then the compiler will convert one of the operands into the type of the other.

The compiler uses the following rules:

If either of the operands is of type **float** then the other operand is converted to the same type.

If either of the operands is of type **long int** or **unsigned long int** then the other operand is converted to the same type.

Otherwise, if either of the operands is of type **int** or **unsigned int** then the other operand is converted to the same type.

Thus **char** type or **unsigned char** type gets the lowest priority.

Using casting you can change these rules.

Example:

```
void main(void) {
int a, c;
long b;
/* The long integer variable b will be treated here as an integer */
c=a+(int) b;
}
```

It is important to note that if the **Project|Configure|C Compiler|Code Generation|Promote char to int** option isn't checked or the **#pragma promotechar+** isn't used, the **char**, respectively **unsigned char**, type operands are not automatically promoted to **int**, respectively **unsigned int**, as in compilers targeted for 16 or 32 bit CPUs.

This helps writing more size and speed efficient code for an 8 bit CPU like the AVR.

To prevent overflow on 8 bit addition or multiplication, casting may be required.

The compiler issues warnings in these situations.

Example:

```
void main(void) {
unsigned char a=30;
unsigned char b=128;
unsigned int c;

/* This will generate an incorrect result, because the multiplication
   is done on 8 bits producing an 8 bit result, which overflows.
   Only after the multiplication, the 8 bit result is promoted to
   unsigned int */
c=a*b;

/* Here casting forces the multiplication to be done on 16 bits,
   producing an 16 bit result, without overflow */
c=(unsigned int) a*b;
}
```

The compiler behaves differently for the following operators:

```
+=  
-=  
*=  
/=   
%=  
&=  
|=  
^=  
<<=  
>>=
```

For these operators, the result is to be written back onto the left-hand side operand (which must be a variable). So the compiler will always convert the right hand side operand into the type of left-hand side operand.

3.10 Operators

The compiler supports the following operators:

```
+      -  
*      /  
%      ++  
--     =  
==     ~  
!      !=  
<      >  
<=     >=  
&      &&  
|      ||  
^      ? :  
<<     >>  
-=     +=  
/=     %=  
&=     *=  
^=     |=  
>>=   <<=  
sizeof
```

3.11 Functions

You may use function prototypes to declare a function. These declarations include information about the function parameters. Example:

```
int alfa(char par1, int par2, long par3);
```

The actual function definition may be written somewhere else as:

```
int alfa(char par1, int par2, long par3) {  
/* Write some statements here */  
  
}
```

The old Kernighan & Ritchie style of writing function definitions is not supported. Function parameters are passed through the **Data Stack**. Function values are returned in registers R30, R31, R22 and R23 (from LSB to MSB).

3.12 Pointers

Due to the Harvard architecture of the AVR microcontroller, with separate address spaces for data (RAM), program (FLASH) and EEPROM memory, the compiler implements three types of pointers. The syntax for pointer declaration is:

```
[<memory attribute>] type * [<memory attribute>]
                        [* [<memory attribute>] ...] pointer_name;
```

or

```
type [<memory attribute>] * [<memory attribute>]
                        [* [<memory attribute>] ...] pointer_name;
```

where type can be any data type.

Variables placed in RAM are accessed using normal pointers.

For accessing constants placed in FLASH memory, the **flash** or **__flash** memory attributes are used.

For accessing variables placed in EEPROM, the **eeprom** or **__eeprom** memory attributes are used.

Although the pointers may point to different memory areas, they are by default stored in RAM.

Example:

```
/* Pointer to a char string placed in RAM */
char *ptr_to_ram="This string is placed in RAM";

/* Pointer to a char string placed in FLASH */
flash char *ptr_to_flash1="This string is placed in FLASH";
char flash *ptr_to_flash2="This string is also placed in FLASH";

/* Pointer to a char string placed in EEPROM */
eeprom char *ptr_to_eeprom1="This string is placed in EEPROM";
char eeprom *ptr_to_eeprom2="This string is also placed in EEPROM";
```

In order to store the pointer itself in other memory areas, like FLASH or EEPROM, the **flash** (**__flash**) or **eeprom** (**__eeprom**) pointer storage memory attributes must be used as in the examples below:

```
/* Pointer stored in FLASH to a char string placed in RAM */
char * flash flash_ptr_to_ram="This string is placed in RAM";

/* Pointer stored in FLASH to a char string placed in FLASH */
flash char * flash flash_ptr_to_flash="This string is placed in FLASH";

/* Pointer stored in FLASH to a char string placed in EEPROM */
eeprom char * flash eeprom_ptr_to_eeprom="This string is placed in EEPROM";

/* Pointer stored in EEPROM to a char string placed in RAM */
char * eeprom eeprom_ptr_to_ram="This string is placed in RAM";

/* Pointer stored in EEPROM to a char string placed in FLASH */
flash char * eeprom eeprom_ptr_to_flash="This string is placed in FLASH";

/* Pointer stored in EEPROM to a char string placed in EEPROM */
eeprom char * eeprom eeprom_ptr_to_eeprom="This string is placed in
EEPROM";
```

CodeVisionAVR

In order to improve the code efficiency several memory models are implemented.

The **TINY** memory model uses 8 bits for storing pointers to the variables placed in RAM. In this memory model you can only have access to the first 256 bytes of RAM.

The **SMALL** memory model uses 16 bits for storing pointers the variables placed in RAM. In this memory model you can have access to 65536 bytes of RAM.

In both **TINY** and **SMALL** memory models pointers to the FLASH memory area use 16 bits. Because in these memory models pointers to the FLASH memory are 16 bits wide, the total size of the constant arrays and literal char strings is limited to 64K. However the total size of the program can be the full amount of FLASH.

In order to remove the above mentioned limitation, there are available two additional memory models: **MEDIUM** and **LARGE**.

The **MEDIUM** memory model is similar to the **SMALL** memory model, except it uses pointers to constants in FLASH that are 32 bits wide. The pointers to functions are however 16 bit wide because they hold the *word* address of the function, so 16 bits are enough to address a function located in all 128kbytes of FLASH.

The **MEDIUM** memory model can be used only for chips with 128kbytes of FLASH.

The **LARGE** memory model is similar to the **SMALL** memory model, except it uses pointers to the FLASH memory area that are 32 bits wide.

The **LARGE** memory model can be used for chips with 256kbytes or more of FLASH.

In all memory models pointers to the EEPROM memory area are 16 bit wide.

Pointers can be grouped in arrays, which can have up to 8 dimensions.

Example:

```
/* Declare and initialize a global array of pointers to strings
   placed in RAM */
char *strings[3]={"One","Two","Three"};

/* Declare and initialize a global array of pointers to strings
   placed in FLASH
   The pointer array itself is also stored in FLASH */
flash char * flash messages[3]={"Message 1","Message 2","Message 3"};

/* Declare some strings in EEPROM */
eeprom char m1[]="aaaa";
eeprom char m2[]="bbbb";

void main(void) {
/* Declare a local array of pointers to the strings placed in EEPROM
   You must note that although the strings are located in EEPROM,
   the pointer array itself is located in RAM */
char eeprom *pp[2];

/* and initialize the array */
pp[0]=m1;
pp[1]=m2;
}
```

CodeVisionAVR

Pointers to functions always access the FLASH memory area. There is no need to use the **flash** or **__flash** memory attributes for these types of pointers.

Example:

```
/* Declare a function */
int sum(int a, int b) {
    return a+b;
}

/* Declare and initialize a global pointer to the function sum */
int (*sum_ptr) (int a, int b)=sum;

void main(void) {
    int i;

    /* Call the function sum using the pointer */
    i=(*sum_ptr) (1,2);
}
```

3.13 Compiler Directives

Compiler specific directives are specified using the **#pragma** command.

You can use the **#pragma warn** directive to enable or disable compiler warnings.

Example:

```
/* Warnings are disabled */
#pragma warn-
/* Write some code here */

/* Warnings are enabled */
#pragma warn+
```

The compiler's code optimizer can be turned on or off using the **#pragma opt** directive. This directive must be placed at the start of the source file.

The default is optimization turned on.

Example:

```
/* Turn optimization off, for testing purposes */
#pragma opt-
```

or

```
/* Turn optimization on */
#pragma opt+
```

If the code optimization is enabled, you can optimize some portions or all the program for size or speed using the **#pragma optsize** directive.

The default state is determined by the **Project|Configure|C Compiler|Code Generation|Optimization** menu setting.

Example:

```
/* The program will be optimized for minimum size */
#pragma optsize+

/* Place your program functions here */

/* Now the program will be optimized for maximum execution speed */
#pragma optsize-

/* Place your program functions here */
```

The automatic saving and restoring of registers affected by the interrupt handler, can be turned on or off using the **#pragma savereg** directive.

CodeVisionAVR

Example:

```
/* Turn registers saving off */
#pragma savereg-

/* interrupt handler */
interrupt [1] void my_irq(void) {
/* now save only the registers that are affected by the routines in the
   interrupt handler, for example R30, R31 and SREG */
#asm
    push r30
    push r31
    in    r30,SREG
    push r30
#endasm

/* place the C code here */
/* .... */
/* now restore SREG, R31 and R30 */
#asm
    pop r30
    out SREG,r30
    pop r31
    pop r30
#endasm
}
/* re-enable register saving for the other interrupts */
#pragma savereg+
```

The default state is automatic saving of registers during interrupts.

The **#pragma savereg** directive is maintained only for compatibility with versions of the compiler prior to V1.24.1. This directive is not recommended for new projects.

The automatic allocation of global variables to registers can be turned on or off using the **#pragma regalloc** directive.

The default state is determined by the **Project|Configure|C Compiler|Code Generation|Automatic Global Register Allocation** check box.

Example:

```
/* the following global variable will be automatically
   allocated to a register */
#pragma regalloc+
unsigned char alfa;

/* the following global variable will not be automatically
   allocated to a register and will be placed in normal RAM */
#pragma regalloc-
unsigned char beta;
```

The ANSI **char** to **int** operands promotion can be turned on or off using the **#pragma promotechar** directive.

Example:

```
/* turn on the ANSI char to int promotion */
#pragma promotechar+

/* turn off the ANSI char to int promotion */
#pragma promotechar-
```

CodeVisionAVR

This option can also be specified in the **Project|Configure|C Compiler|Code Generation|Promote char to int** menu.

Treating **char** by default as an unsigned 8 bit can be turned on or off using the **#pragma uchar** directive.

Example:

```
/* char will be unsigned by default */
#pragma uchar+

/* char will be signed by default */
#pragma uchar-
```

This option can also be specified in the **Project|Configure|C Compiler|Code Generation|char is unsigned** menu.

The **#pragma library** directive is used for specifying the necessity to compile/link a specific library file.
Example:

```
#pragma library mylib.lib
```

The **#pragma glibdef+** directive is used for compatibility with projects, created with versions of CodeVisionAVR prior to V1.0.2.2, where the **Project|Configure|C Compiler|Global #define** option was enabled.

It signals the compiler that macros are globally visible in all the program modules of a project.

This directive must be placed in beginning of the first source file of the project.

By default this directive is not active, so macros are visible only in the program module where they are defined.

The **#pragma vector** directive is used for specifying that the next declared function is an interrupt service routine.

Example:

```
/* Vector numbers are for the AT90S8515 */
/* Specify the vector number using the #pragma vector directive */
#pragma vector=8

/* Called automatically on TIMER0 overflow */
__interrupt void timer0_overflow(void) {
/* Place your code here */

}
```

The **#pragma vector** preprocessor directive and the **__interrupt** keyword are used for compatibility with other C compilers for the Atmel AVR.

The **#pragma keep+** directive forces a function, global variable or global constant to be linked even if it wasn't used anywhere in the program.

CodeVisionAVR

Example:

```
/* force the next function to be linked even if it's not used */
#pragma keep+

int func1(int a, int b)
{
return a+b;
}

/* the next function will not be linked if it's not used
#pragma keep-

int func2(int a, int b)
{
return a-b;
}
```

3.14 Accessing the I/O Registers

The compiler uses the **sfrb** and **sfrw** keywords to access the AVR microcontroller's I/O Registers, using the IN and OUT assembly instructions.

Example:

```
/* Define the SFRs */
sfrb PINA=0x19; /* 8 bit access to the SFR */
sfrw TCNT1=0x2c; /* 16 bit access to the SFR */

void main(void) {
unsigned char a;
a=PINA; /* Read PORTA input pins */
TCNT1=0x1111; /* Write to TCNT1L & TCNT1H registers */
}
```

The addresses of I/O registers are predefined in the following header files, located in the `.\INC` subdirectory:

```
tiny10.h
tiny13.h
tiny167.h
tiny22.h
tiny2313.h
tiny24.h
tiny25.h
tiny26.h
tiny261.h
tiny43u.h
tiny44.h
tiny45.h
tiny461.h
tiny48.h
tiny5.h
tiny84.h
tiny85.h
tiny861.h
tiny87.h
tiny88.h
90can32.h
90can64.h
90can128.h
90pwm2.h
90pwm2b.h
90pwm216.h
90pwm3.h
90pwm3b.h
90pwm316.h
90usb1286.h
90usb1287.h
90usb162.h
90usb646.h
90usb647.h
90usb82.h
90s2313.h
90s2323.h
90s2333.h
90s2343.h
90s4414.h
```

CodeVisionAVR

90s4433.h
90s4434.h
90s8515.h
90s8534.h
90s8535.h
mega103.h
mega128.h
mega1280.h
mega1281.h
mega1284p.h
mega16.h
mega16m1.h
mega16u4.h
mega161.h
mega162.h
mega163.h
mega164.h
mega165.h
mega168.h
mega168p.h
mega169.h
mega2560.h
mega2561.h
mega32.h
mega32c1.h
mega32m1.h
mega32u4.h
mega32u6.h
mega323.h
mega324.h
mega325.h
mega325p.h
mega3250.h
mega3250p.h
mega328p.h
mega329.h
mega329p.h
mega3290.h
mega3290p.h
mega406.h
mega48.h
mega48p.h
mega603.h
mega64.h
mega64c1.h
mega64m1.h
mega640.h
mega644.h
mega644p.h
mega645.h
mega6450.h
mega649.h
mega6490.h
mega8.h
mega8515.h
mega8535.h
mega88.h
mega88p.h
xmega128a1.h
xmega128a3.h

CodeVisionAVR

xmega128a4.h
xmega16a4.h
xmega192a1.h
xmega192a3.h
xmega256a1.h
xmega256a3.h
xmega32a4.h
xmega64a1.h
xmega64a3.h
xmega64a4.h
ata6285.h
ata6286.h
ata6289.h
43usb355.h
76c711.h
86rf401.h
94k.h

The header file, corresponding to the chip that you use, must be included at the beginning of your program.

Alternatively the **io.h** header file can be included. This file contains the definitions for the I/O registers for all the chips supported by the compiler.

3.14.1 Bit level access to the I/O Registers

The bit level access to the I/O registers is accomplished using bit selectors appended after the name of the I/O register.

Because bit level access to I/O registers is done using the CBI, SBI, SBIC and SBIS instructions, the register address must be in the 0 to 1Fh range for **sfrb** and in the 0 to 1Eh range for **sfrw**.

Example:

```
sfrb PORTA=0x1b;
sfrb DDRA=0x18;
sfrb PINA=0x19;

void main(void) {
/* set bit 0 of Port A as output */
DDRA.0=1;

/* set bit 1 of Port A as input */
DDRA.1=0;

/* set bit 0 of Port A output */
PORTA.0=1;

/* test bit 1 input of Port A */
if (PINA.1) { /* place some code here */ };

/* ..... */

}
```

To improve the readability of the program you may wish to **#define** symbolic names to the bits in I/O registers:

```
sfrb PINA=0x19;
#define alarm_input PINA.2
void main(void)
{
/* test bit 2 input of Port A */
if (alarm_input) { /* place some code here */ };
/* ..... */
}
```

CodeVisionAVR

It is important to note that bit selector access to I/O registers located in internal RAM above address 5Fh (like PORTF for the ATmega128 for example) will not work, because the CBI, SBI, SBIC and SBIS instructions can't be used for RAM access.

3.15 Accessing the EEPROM

Accessing the AVR internal EEPROM is accomplished using global variables, preceded by the **eeeprom** or **__eeeprom** memory attributes.

Example:

```
/* The value 1 is stored in the EEPROM during chip programming */
eeeprom int alfa=1;

eeeprom char beta;
eeeprom long array1[5];

/* The string is stored in the EEPROM during chip programming */
eeeprom char string[]="Hello";

void main(void) {
int i;

/* Pointer to EEPROM */
int eeeprom *ptr_to_eeeprom;

/* Write directly the value 0x55 to the EEPROM */
alfa=0x55;
/* or indirectly by using a pointer */
ptr_to_eeeprom=&alfa;
*ptr_to_eeeprom=0x55;

/* Read directly the value from the EEPROM */
i=alfa;
/* or indirectly by using a pointer */
i=*ptr_to_eeeprom;
}
```

Pointers to the EEPROM always occupy 16 bits in memory.

3.16 Using Interrupts

The access to the AVR interrupt system is implemented with the **interrupt** keyword.

Example:

```
/* Vector numbers are for the AT90S8515 */

/* Called automatically on external interrupt */
interrupt [2] void external_int0(void) {
/* Place your code here */

}

/* Called automatically on TIMER0 overflow */
interrupt [8] void timer0_overflow(void) {
/* Place your code here */

}
```

Interrupt vector numbers start with 1.

The compiler will automatically save the affected registers when calling the interrupt functions and restore them back on exit.

A RETI assembly instruction is placed at the end of the interrupt function.

Interrupt functions can't return a value nor have parameters.

You must also set the corresponding bits in the peripheral control registers to configure the interrupt system and enable the interrupts.

Another possibility to declare an interrupt service routine is by using the **#pragma vector** preprocessor directive and the **__interrupt** keyword.

#pragma vector is used for specifying that the next declared function is an interrupt service routine.

Example:

```
/* Vector numbers are for the AT90S8515 */

/* Specify the vector number using the #pragma vector directive */
#pragma vector=2

/* Called automatically on external interrupt */
__interrupt void external_int0(void) {
/* Place your code here */

}

/* Specify the vector number using the #pragma vector directive */
#pragma vector=8

/* Called automatically on TIMER0 overflow */
__interrupt void timer0_overflow(void) {
/* Place your code here */

}
```

The **#pragma vector** preprocessor directive and the **__interrupt** keyword are used for compatibility with other C compilers for the Atmel AVR.

CodeVisionAVR

The automatic saving and restoring of registers affected by the interrupt handler, can be turned on or off using the **#pragma savereg** directive.

Example:

```
/* Turn registers saving off */
#pragma savereg-

/* interrupt handler */
interrupt [1] void my_irq(void) {
/* now save only the registers that are affected by the routines in the
   interrupt handler, for example R30, R31 and SREG */
#asm
    push r30
    push r31
    in   r30,SREG
    push r30
#endasm

/* place the C code here */
/* .... */
/* now restore SREG, R31 and R30 */
#asm
    pop r30
    out SREG,r30
    pop r31
    pop r30
#endasm
}
/* re-enable register saving for the other interrupts */
#pragma savereg+
```

The default state is automatic saving of registers during interrupts.

The **#pragma savereg** directive is maintained only for compatibility with versions of the compiler prior to V1.24.1. This directive is not recommended for new projects.

3.17 RAM Memory Organization and Register Allocation

A compiled program has the following memory map:

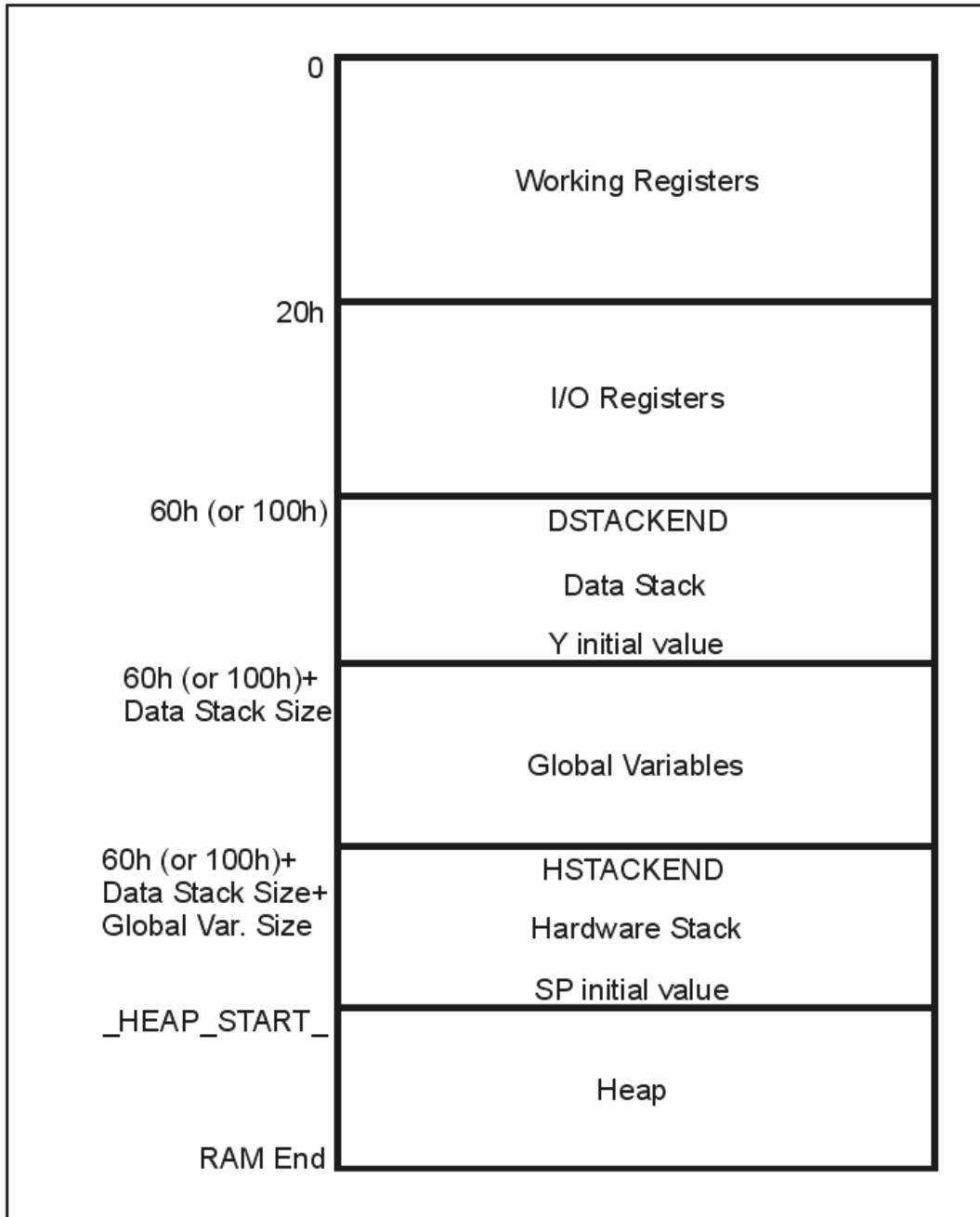

The **Working Registers** area contains 32x8 bit general purpose working registers.

CodeVisionAVR

The register usage depends on the type of the AVR core for which code is generated:

- **standard core**: the compiler uses the following registers: R0, R1, R15, R22, R23, R24, R25, R26, R27, R28, R29, R30 and R31.
Also some of the registers from R2 to R15 may be allocated by the compiler for global and local bit variables. The rest of unused registers, in this range, are allocated for global char and int variables and pointers. Registers R16 to R21 are allocated for local char and int variables.
- **reduced core** (ATtiny10): the compiler uses the following registers: R16, R17, R22, R23, R24, R25, R26, R27, R28, R29, R30 and R31.
No registers may be allocated by the compiler for global and local bit variables.
Registers R18 to R21 are allocated for local char and int variables.

The **I/O Registers** area contains 64 addresses for the CPU peripheral functions as Port Control Registers, Timer/Counters and other I/O functions. You may freely use these registers in your assembly programs.

The **Data Stack** area is used to dynamically store local variables, passing function parameters and saving registers during interrupt routine servicing:

- **standard core**: R0, R1, R15, R22, R23, R24, R25, R26, R27, R30, R31 and SREG
- **reduced core**: R16, R17, R22, R23, R24, R25, R26, R27, R30, R31 and SREG.

The **Data Stack Pointer** is implemented using the Y register.

At start-up the **Data Stack Pointer** is initialized with the value 5Fh (or FFh for some chips)+Data Stack Size.

When saving a value in the **Data Stack**, the **Data Stack Pointer** is decremented.

When the value is retrieved, the **Data Stack Pointer** is incremented back.

When configuring the compiler, in the **Project|Configure|C Compiler|Code Generation** menu, you must specify a sufficient **Data Stack Size**, so it will not overlap the **I/O Register** area during program execution.

The **Global Variables** area is used to statically store the global variables during program execution. The size of this area can be computed by summing the size of all the declared global variables.

The **Hardware Stack** area is used for storing the functions return addresses.

The SP register is used as a stack pointer and is initialized at start-up with value of the **_HEAP_START_ -1** address.

During the program execution the **Hardware Stack** grows downwards to the **Global Variables** area.

When configuring the compiler you have the option to place the strings **DSTACKEND**, respectively **HSTACKEND**, at the end of the **Data Stack**, respectively **Hardware Stack** areas.

When you debug the program with AVR Studio you may see if these strings are overwritten, and consequently modify the **Data Stack Size** using the **Project|Configure|C Compiler|Code Generation** menu command.

When your program runs correctly, you may disable the placement of the strings in order to reduce code size.

The **Heap** is a memory area located between the **Hardware Stack** and the **RAM end**.

It is used by the memory allocation functions from the Standard Library: malloc, calloc, realloc and free.

CodeVisionAVR

The **Heap** size must be specified in the **Project|Configure|C Compiler|Code Generation** menu. It can be calculated using the following formulae:

$$heap_size = (n + 1) \cdot 4 + \sum_{i=1}^n block_size_i$$

where: n is the number of memory blocks that will be allocated in the **Heap**

$block_size_i$ is the size of the memory block i

If the memory allocation functions will not be used, then the **Heap** size must be specified as zero.

3.18 Using an External Startup Assembly File

In every program the CodeVisionAVR C compiler automatically generates a code sequence to make the following initializations immediately after the AVR chip reset:

1. interrupt vector jump table
2. global interrupt disable
3. EEPROM access disable
4. Watchdog Timer disable
5. external RAM access and wait state enable if necessary
6. clear registers R2 ... R14 (for AVR8 standard core chips)
7. clear the RAM
8. initialize the global variables located in RAM
9. initialize the **Data Stack Pointer** register Y
10. initialize the **Stack Pointer** register SP
11. initialize the UBRR register if necessary

The automatic generation of code sequences 2 to 8 can be disabled by checking the **Use an External Startup Initialization File** check box in the **Project|Configure|C Compiler|Code Generation** dialog window. The C compiler will then include, in the generated .asm file, the code sequences from an external file that must be named **STARTUP.ASM**. This file must be located in the directory where your main C source file resides.

You can write your own **STARTUP.ASM** file to customize or add some features to your program. The code sequences from this file will be immediately executed after the chip reset.

A basic **STARTUP.ASM** file is supplied with the compiler distribution and is located in the .\BIN directory.

Here's the content of this file:

```
;CodeVisionAVR C Compiler
;(C) 1998-2008 Pavel Haiduc, HP InfoTech s.r.l.

    .EQU __CLEAR_START=0X60 ;START ADDRESS OF RAM AREA TO CLEAR
                                ;SET THIS ADDRESS TO 0X100 FOR THE
                                ;ATmega128 OR ATmega64 CHIPS
    .EQU __CLEAR_SIZE=256    ;SIZE OF RAM AREA TO CLEAR IN BYTES

    CLI                ;DISABLE INTERRUPTS
    CLR   R30
    OUT  EECR,R30    ;DISABLE EEPROM ACCESS

;DISABLE THE WATCHDOG
    LDI  R31,0x18
    OUT  WDTCR,R31
    OUT  WDTCR,R30

    OUT  MCUCR,R30 ;MCUCR=0, NO EXTERNAL RAM ACCESS

;CLEAR R2-R14
    LDI  R24,13
    LDI  R26,2
    CLR  R27
__CLEAR_REG:
    ST   X+,R30
    DEC  R24
    BRNE __CLEAR_REG
```

CodeVisionAVR

```
;CLEAR RAM
    LDI R24,LOW(__CLEAR_SIZE)
    LDI R25,HIGH(__CLEAR_SIZE)
    LDI R26,LOW(__CLEAR_START)
    LDI R27,HIGH(__CLEAR_START)
__CLEAR_RAM:
    ST X+,R30
    SBIW R24,1
    BRNE __CLEAR_RAM

;GLOBAL VARIABLES INITIALIZATION
    LDI R30,LOW(__GLOBAL_INI_TBL*2)
    LDI R31,HIGH(__GLOBAL_INI_TBL*2)
__GLOBAL_INI_NEXT:
    LPM
    ADIW R30,1
    MOV R24,R0
    LPM
    ADIW R30,1
    MOV R25,R0
    SBIW R24,0
    BREQ __GLOBAL_INI_END
    LPM
    ADIW R30,1
    MOV R26,R0
    LPM
    ADIW R30,1
    MOV R27,R0
    LPM
    ADIW R30,1
    MOV R1,R0
    LPM
    ADIW R30,1
    MOV R22,R30
    MOV R23,R31
    MOV R31,R0
    MOV R30,R1
__GLOBAL_INI_LOOP:
    LPM
    ADIW R30,1
    ST X+,R0
    SBIW R24,1
    BRNE __GLOBAL_INI_LOOP
    MOV R30,R22
    MOV R31,R23
    RJMP __GLOBAL_INI_NEXT
__GLOBAL_INI_END:
```

The **__CLEAR_START** and **__CLEAR_SIZE** constants can be changed to specify which area of RAM to clear at program initialization.

The **__GLOBAL_INI_TBL** label must be located at the start of a table containing the information necessary to initialize the global variables located in RAM. This table is automatically generated by the compiler.

3.19 Including Assembly Language in Your Program

You can include assembly language anywhere in your program using the **#asm** and **#endasm** directives.

Example:

```
void delay(unsigned char i) {
while (i--) {
    /* Assembly language code sequence */
    #asm
        nop
        nop
    #endasm
};
}
```

Inline assembly may also be used.

Example:

```
#asm("sei") /* enable interrupts */
```

The registers R0, R1, R22, R23, R24, R25, R26, R27, R30 and R31 can be freely used in assembly routines.

However when using them in an interrupt service routine the programmer must save, respectively restore, them on entry, respectively on exit, of this routine.

3.19.1 Calling Assembly Functions from C

The following example shows how to access functions written in assembly language from a C program:

```
// function in assembler declaration
// this function will return a+b+c
#pragma warn- // this will prevent warnings
int sum_abc(int a, int b, unsigned char c) {
#asm
    ldd    r30,y+3 ;R30=LSB a
    ldd    r31,y+4 ;R31=MSB a
    ldd    r26,y+1 ;R26=LSB b
    ldd    r27,y+2 ;R27=MSB b
    add    r30,r26 ; (R31,R30)=a+b
    adc    r31,r27
    ld     r26,y    ;R26=c
    clr    r27      ;promote unsigned char c to int
    add    r30,r26 ; (R31,R30)=(R31,R30)+c
    adc    r31,r27
#endasm
}
#pragma warn+ // enable warnings

void main(void) {
int r;
// now we call the function and store the result in r
r=sum_abc(2,4,6);
}
```

The compiler passes function parameters using the **Data Stack**.

First it pushes the integer parameter a, then b, and finally the unsigned char parameter c.

On every push the Y register pair decrements by the size of the parameter (4 for long int, 2 for int, 1 for char).

For multiple byte parameters the MSB is pushed first.

As it is seen the **Data Stack** grows downward.

After all the functions parameters were pushed on the **Data Stack**, the Y register points to the last parameter c, so the function can read its value in R26 using the instruction: `ld r26,y`.

The b parameter was pushed before c, so it is at a higher address in the **Data Stack**.

The function will read it using: `ldd r27,y+2` (MSB) and `ldd r26,y+1` (LSB).

The MSB was pushed first, so it is at a higher address.

The a parameter was pushed before b, so it is at a higher address in the **Data Stack**.

The function will read it using: `ldd r31,y+4` (MSB) and `ldd r30,y+3` (LSB).

The functions return their values in the registers (from LSB to MSB):

- R30 for char and unsigned char
- R30, R31 for int and unsigned int
- R30, R31, R22, R23 for long and unsigned long.

So our function must return its result in the R30, R31 registers.

After the return from the function the compiler automatically generates code to reclaim the **Data Stack** space used by the function parameters.

The **#pragma warn-** compiler directive will prevent the compiler from generating a warning that the function does not return a value.

This is needed because the compiler does not know what it is done in the assembler portion of the function.

3.20 Creating Libraries

In order to create your own libraries, the following steps must be followed:

1. Create a header .h file with the prototypes of the library functions. Select the **File|New** menu command or press the  toolbar button. The following dialog window will open:

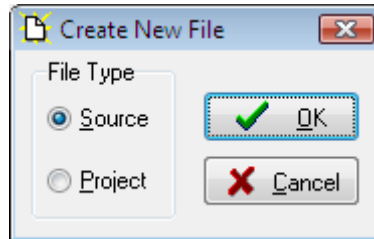

Select **Source** and press the **OK** button. A new editor window will be opened for the **untitled.c** source file. Type in the prototype for your function. Example:

```
/* this #pragma directive will prevent the compiler from generating a
   warning that the function was declared, but not used in the program */
#pragma used+
/* library function prototypes */
int sum(int a, int b);
int mul(int a, int b);
#pragma used-
/* this #pragma directive will tell the compiler to compile/link the
   functions from the mylib.lib library */
#pragma library mylib.lib
```

Save the file, under a new name, in the **.INC** directory using the **File|Save As** menu command, for example **mylib.h** :

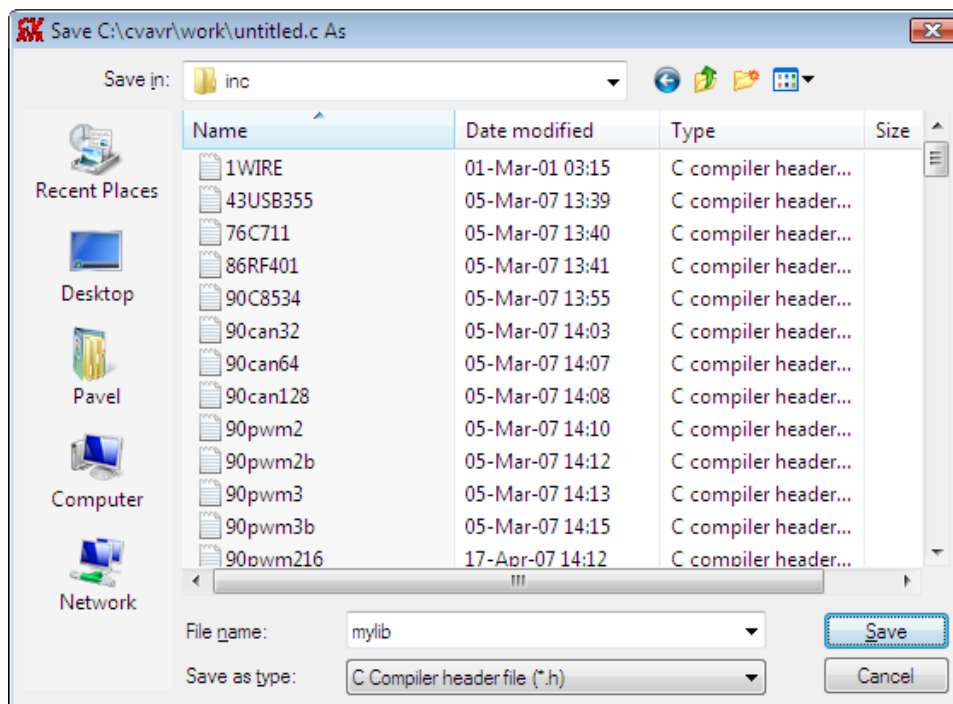

CodeVisionAVR

2. Create the library file.

Select the **File|New** menu command or press the **New** toolbar button.

The following dialog window will open:

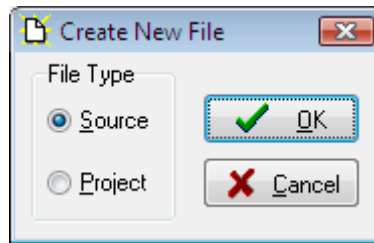

Select **Source** and press the **OK** button.

A new editor window will be opened for the **untitled.c** source file.

Type in the definitions for your functions.

Example:

```
int sum(int a, int b) {  
    return a+b;  
}
```

```
int mul(int a, int b) {  
    return a*b;  
}
```

Save the file, under a new name, for example **mylib.c** , in any directory using the **File|Save As** menu command:

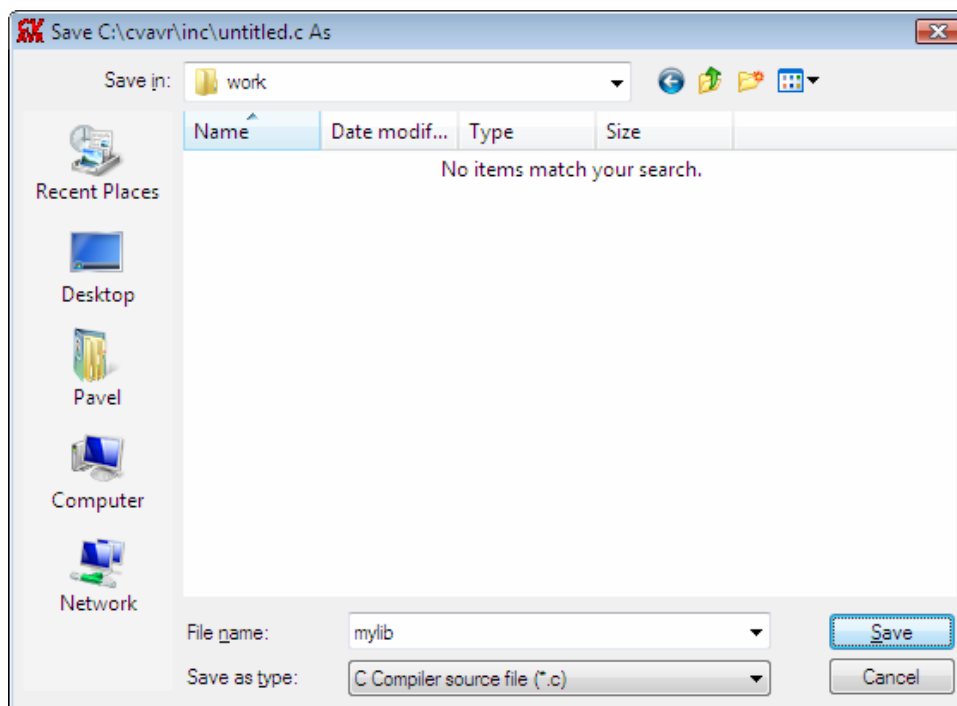

CodeVisionAVR

Finally use the **File|Convert to Library** menu command or the  toolbar button, to save the currently opened .c file under the name **mylib.lib** in the **.LIB** directory:

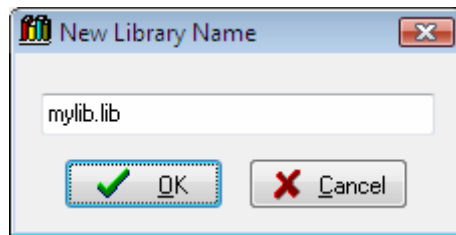

In order to use the newly created **mylib.lib** library, just **#include** the **mylib.h** header file in the beginning of your program.

Example:

```
#include <mylib.h>
```

Library files usually reside in the **.LIB** directory, but paths to additional directories can be added in the **Project|Configure|C Compiler|Paths|Library paths** menu.

3.21 Using the AVR Studio Debugger

CodeVisionAVR is designed to work in conjunction with the Atmel AVR Studio debugger version 4.14 or later.

The compiler will generate for the AVR Studio debugger an extended COFF object file that allows watching structures and unions. AVR Studio 4 prior to version 4.06 does not support the extended COFF object file format, so it can't be used with CodeVisionAVR.

In order to be able to do C source level debugging using AVR Studio, you must select the **COFF Output File Format** in the **Project|Configure|C Compiler|Code Generation** menu option.

The AVR Studio Debugger is invoked using the **Tools|Debugger** menu command or the  toolbar button.

After AVR Studio is launched, the user must first select **File|Open File (Ctrl+O)** keys in order to load the COFF file to be debugged.

After the COFF file is loaded, and no AVR Studio project file exists for this COFF file, the debugger will open a **Select device and debug platform** dialog window.

In this window the user must specify the Debug Platform: ICE or AVR Simulator and the AVR Device type.

Pressing the **Finish** button will create a new AVR Studio project associated with the COFF file.

If an AVR Studio project associated with the COFF file already exists, the user will be asked if the debugger may load it.

Once the program is loaded, it can be launched in execution using the **Debug|Run** menu command, by pressing the **F5** key or by pressing the **Run** toolbar button.

Program execution can be stopped at any time using the **Debug|Break** menu command, by pressing **Ctrl+F5** keys or by pressing the **Break** toolbar button.

To single step the program, the **Debug|Step Into (F11)** key, **Debug|Step Over (F10)** key, **Debug|Step Out (Shift+F11)** keys) menu commands or the corresponding toolbar buttons should be used.

In order to stop the program execution at a specific source line, the **Debug|Toggle Breakpoint** menu command, the **F9** key or the corresponding toolbar button should be used.

In order to watch program variables, the user must select **Debug|Quickwatch (Shift+F9)** keys) menu command or press the **Quickwatch** toolbar button, and specify the name of the variable in the **QuickWatch** window in the **Name** column.

The AVR chip registers can be viewed using the **View|Register** menu command or by pressing the **Alt+0** keys. The registers can be also viewed in the **Workspace|I/O** window in the **Register 0-15** and **Register 16-31** tree branches.

The AVR chip PC, SP, X, Y, Z registers and status flags can be viewed in the **Workspace|I/O** window in the **Processor** tree branch.

The contents of the FLASH, RAM and EEPROM memories can be viewed using the **View|Memory** menu command or by pressing the **Alt+4** keys.

The I/O registers can be viewed in the **Workspace|I/O** window in the **I/O** branch.

To obtain more information about using AVR Studio please consult it's Help system.

3.22 Compiling the Sample Code of the ATxmega Application Notes from Atmel

In order to support the new ATxmega chips, Atmel has released a number of Application Notes that are available for download at: http://www.atmel.com/dyn/products/app_notes.asp?part_id=4310

The sample code for these Application Notes can be easily compiled with CodeVisionAVR. For this purpose the header file **avr_compiler.h** supplied for each Application Note must be replaced with the same file located in the `..INC` directory of the CodeVisionAVR installation.

3.23 Hints

In order to decrease code size and improve the execution speed, you must apply the following rules:

- If possible use **unsigned** variables;
- Use the smallest data type possible, i.e. **bit** and **unsigned char**;
- The size of the bit variables, allocated to the program in the **Project|Configure|C Compiler|Code Generation|Bit Variables Size** list box, should be as low as possible, in order to free registers for allocation to other global variables;
- If possible use the smallest possible memory model (TINY or SMALL);
- Always store constant strings in FLASH by using the **flash** or **__flash** memory models;
- After finishing debugging your program, compile it again with the **Stack End Markers** option disabled.

3.24 Limitations

The current version of the CodeVisionAVR C compiler has the following limitations:

- the **long long**, **double**, **_Complex** and **_Imaginary** data types are not yet supported
- the **bit** data type is not supported for the reduced core, used in chips like ATtiny10
- functions with variable number of parameters are not supported for reduced core chips
- signal handling (`signal.h`) is not implemented yet
- date and time functions (`time.h`) are not implemented yet
- extended multibyte/wide character utilities (`wchar.h`) are not implemented
- wide character classification and mapping utilities (`wctype.h`) are not implemented
- the **printf**, **sprintf**, **snprintf**, **vprintf**, **vsprintf** and **vsnprintf** Standard C Input/Output Functions can't output strings longer than 255 characters for the **%s** format specifier
- the LCD, 1 Wire, I2C, Philips PCF8563, Philips PCF8583, Maxim/Dallas Semiconductor DS1302, DS1307, DS1621, DS2430, DS2433, National Semiconductor LM75 libraries do not yet support the ATxmega chips
- the size of the compiled code is limited for the Evaluation version
- the libraries for Philips PCF8563, Philips PCF8583, Maxim/Dallas Semiconductor DS1302, DS1307, 4x40 character LCD functions are not available in the Evaluation version.

4. Library Functions Reference

You must **#include** the appropriate header files for the library functions that you use in your program.

Example:

```
/* Header files are included before using the functions */
#include <stdlib.h> // for abs
#include <stdio.h> // for putsf

void main(void) {
int a,b;
a=-99;
/* Here you actually use the functions */
b=abs(a);
putsf("Hello world");
}
```

4.1 Character Type Functions

The prototypes for these functions are placed in the file **ctype.h**, located in the `.INC` subdirectory. This file must be **#include** -ed before using the functions.

unsigned char isalnum(char c)

returns 1 if c is alphanumeric.

unsigned char isalpha(char c)

returns 1 if c is alphabetic.

unsigned char isascii(char c)

returns 1 if c is an ASCII character (0..127).

unsigned char iscntrl(char c)

returns 1 if c is a control character (0..31 or 127).

unsigned char isdigit(char c)

returns 1 if c is a decimal digit.

unsigned char islower(char c)

returns 1 if c is a lower case alphabetic character.

unsigned char isprint(char c)

returns 1 if c is a printable character (32..127).

unsigned char ispunct(char c)

returns 1 if c is a punctuation character (all but control and alphanumeric).

unsigned char isspace(char c)

returns 1 c is a white-space character (space, CR, HT).

unsigned char isupper(char c)

returns 1 if c is an upper-case alphabetic character.

unsigned char isxdigit(char c)

returns 1 if c is a hexadecimal digit.

char toascii(char c)

returns the ASCII equivalent of character c.

unsigned char toint(char c)

interprets c as a hexadecimal digit and returns an unsigned char from 0 to 15.

char tolower(char c)

returns the lower case of c if c is an upper case character, else c.

char toupper(char c)

returns the upper case of c if c is a lower case character, else c.

4.2 Standard C Input/Output Functions

The prototypes for these functions are placed in the file **stdio.h**, located in the **.INC** subdirectory. This file must be **#include** -ed before using the functions.

The standard C language I/O functions were adapted to work on embedded microcontrollers with limited resources.

The lowest level Input/Output functions are:

char getchar(void)

returns a character received by the UART, using polling.

void putchar(char c)

transmits the character c using the UART, using polling.

Prior to using these functions you must:

- initialize the UART's Baud rate
- enable the UART transmitter
- enable the UART receiver.

Example:

```
#include <mega8515.h>
#include <stdio.h>

/* quartz crystal frequency [Hz] */
#define xtal 4000000L

/* Baud rate */
#define baud 9600

void main(void) {
char k;

/* initialize the USART control register
   TX and RX enabled, no interrupts, 8 data bits */
UCSRA=0x00;
UCSRB=0x18;
UCSRC=0x86;

/* initialize the USART's baud rate */
UBRRH=(xtal/16/baud-1) >> 8;
UBRRL=(xtal/16/baud-1) & 0xFF;
```

CodeVisionAVR

```
while (1) {
    /* receive the character */
    k=getchar();
    /* and echo it back */
    putchar(k);
};
}
```

If you intend to use other peripherals for Input/Output, you must modify accordingly the **getchar** and **putchar** functions like in the example below:

```
#include <stdio.h>

/* inform the compiler that an alternate version
of the getchar function will be used */
#define _ALTERNATE_GETCHAR_

/* now define the new getchar function */
char getchar(void) {
/* write your code here */

}

/* inform the compiler that an alternate version
of the putchar function will be used */
#define _ALTERNATE_PUTCHAR_

/* now define the new putchar function */
void putchar(char c) {
/* write your code here */

}
```

For the ATxmega chips the **getchar** and **putchar** functions use by default the **USARTC0**. If you wish to use another USART, you must define the **_ATXMEGA_USART_** preprocessor macro prior to **#include** the **stdio.h** header file, like in the example below:

```
/* use the ATxmega128A1 USARTD0 for getchar and putchar functions */
#define _ATXMEGA_USART_ USARTD0

/* use the Standard C I/O functions */
#include <stdio.h>
```

The **_ATXMEGA_USART_** macro needs to be defined only once in the whole program, as the compiler will treat it like it is globally defined.

All the high level Input/Output functions use **getchar** and **putchar**.

void puts(char *str)

outputs, using **putchar**, the null terminated character string **str**, located in RAM, followed by a new line character.

void putsf(char flash *str)

outputs, using **putchar**, the null terminated character string **str**, located in FLASH, followed by a new line character.

CodeVisionAVR

int printf(char flash *fmtstr [, arg1, arg2, ...])

outputs formatted text, using **putchar**, according to the format specifiers in the **fmtstr** string. The format specifier string **fmtstr** is constant and must be located in FLASH memory. The implementation of **printf** is a reduced version of the standard C function. This was necessary due to the specific needs of an embedded system and because the full implementation would require a large amount of FLASH memory space. The function returns the number of outputted characters.

The format specifier string has the following structure:

```
%[flags][width][.precision][l]type_char
```

The optional **flags** characters are:

- '-' left-justifies the result, padding on the right with spaces. If it's not present, the result will be right-justified, padded on the left with zeros or spaces;
- '+' signed conversion results will always begin with a '+' or '-' sign;
- ' ' if the value isn't negative, the conversion result will begin with a space. If the value is negative then it will begin with a '-' sign.

The optional **width** specifier sets the minimal width of an output value. If the result of the conversion is wider than the field width, the field will be expanded to accommodate the result, so not to cause field truncation.

The following width specifiers are supported:

- n - at least n characters are outputted. If the result has less than n characters, then it's field will be padded with spaces. If the '-' flag is used, the result field will be padded on the right, otherwise it will be padded on the left;

- 0n - at least n characters are outputted. If the result has less than n characters, it is padded on the left with zeros.

The optional **precision** specifier sets the maximal number of characters or minimal number of integer digits that may be outputted.

For the 'e', 'E' and 'f' conversion type characters the precision specifier sets the number of digits that will be outputted to the right of the decimal point.

The precision specifier always begins with a '.' character in order to separate it from the width specifier.

The following precision specifiers are supported:

- none - the precision is set to 1 for the 'i', 'd', 'u', 'x', 'X' conversion type characters. For the 's' and 'p' conversion type characters, the char string will be outputted up to the first null character;

- .0 - the precision is set to 1 for the 'i', 'd', 'u', 'x', 'X' type characters;

- .n - n characters or n decimal places are outputted.

For the 'i', 'd', 'u', 'x', 'X' conversion type characters, if the value has less than n digits, then it will be padded on the left with zeros. If it has more than n digits then it will not be truncated.

For the 's' and 'p' conversion type characters, no more than n characters from the char string will be outputted.

For the 'e', 'E' and 'f' conversion type characters, n digits will be outputted to the right of the decimal point.

The precision specifier has no effect on the 'c' conversion type character.

The optional 'l' input size modifier specifies that the function argument must be treated as a long int for the 'i', 'd', 'u', 'x', 'X' conversion type characters.

CodeVisionAVR

The **type_char** conversion type character is used to specify the way the function argument will be treated.

The following conversion type characters are supported:

- 'i' - the function argument is a signed decimal integer;
- 'd' - the function argument is a signed decimal integer;
- 'u' - the function argument is an unsigned decimal integer;
- 'e' - the function argument is a float, that will be outputted using the [-]d.dddddd e[-]dd format
- 'E' - the function argument is a float, that will be outputted using the [-]d.dddddd E[-]dd format
- 'f' - the function argument is a float, that will be outputted using the [-]ddd.dddddd format
- 'x' - the function argument is an unsigned hexadecimal integer, that will be outputted with lowercase characters;
- 'X' - the function argument is an unsigned hexadecimal integer, that will be outputted with uppercase characters;
- 'c' - the function argument is a single character;
- 's' - the function argument is a pointer to a null terminated char string located in RAM;
- 'p' - the function argument is a pointer to a null terminated char string located in FLASH;
- '%' - the '%' character will be outputted.

int sprintf(char *str, char flash *fmtstr [, arg1, arg2, ...])

this function is identical to **printf** except that the formatted text is placed in the null terminated character string **str**.

The function returns the number of outputted characters.

int snprintf(char *str, unsigned char size, char flash *fmtstr [, arg1, arg2, ...]) *for the TINY memory model.*

int snprintf(char *str, unsigned int size, char flash *fmtstr [, arg1, arg2, ...]) *for the other memory models.*

this function is identical to **sprintf** except that at most **size** (including the null terminator) characters are placed in the character string **str**.

The function returns the number of outputted characters.

In order to reduce program code size, there is the **Project|Configure|C Compiler|Code Generation|(s)printf Features** option.

It allows linking different versions of the printf and sprintf functions, with only the features that are really required by the program.

The following **(s)printf features** are available:

- **int** - the following conversion type characters are supported: 'c', 's', 'p', 'i', 'd', 'u', 'x', 'X', '%', no width or precision specifiers are supported, only the '+' and '-' flags are supported, no input size modifiers are supported
- **int, width** - the following conversion type characters are supported: 'c', 's', 'p', 'i', 'd', 'u', 'x', 'X', '%', the width specifier is supported, the precision specifier is not supported, only the '+', '-', '0' and '-' flags are supported, no input size modifiers are supported
- **long, width** - the following conversion type characters are supported: 'c', 's', 'p', 'i', 'd', 'u', 'x', 'X', '%', the width specifier is supported, the precision specifier is not supported, only the '+', '-', '0' and '-' flags are supported, only the 'l' input size modifier is supported
- **long, width, precision** - the following conversion type characters are supported: 'c', 's', 'p', 'i', 'd', 'u', 'x', 'X', '%', the width and precision specifiers are supported, only the '+', '-', '0' and '-' flags are supported, only the 'l' input size modifier is supported
- **float, width, precision** - the following conversion type characters are supported: 'c', 's', 'p', 'i', 'd', 'u', 'e', 'E', 'f', 'x', 'X', '%', the width and precision specifiers are supported, only the '+', '-', '0' and '-' flags are supported, only the 'l' input size modifier is supported.

The more features are selected, the larger is the code size generated for the printf and sprintf functions.

int vprintf(char flash *fmtstr, va_list argptr)

this function is identical to **printf** except that the **argptr** pointer, of **va_list** type, points to the variable list of arguments. The **va_list** type is defined in the `stdarg.h` header file. The function returns the number of outputed characters.

int vsprintf(char *str, char flash *fmtstr, va_list argptr)

this function is identical to **sprintf** except that the **argptr** pointer, of **va_list** type, points to the variable list of arguments. The **va_list** type is defined in the `stdarg.h` header file. The function returns the number of outputed characters.

int vsnprintf(char *str, unsigned char size, char flash *fmtstr, va_list argptr) *for the TINY memory model.*

int vsnprintf(char *str, unsigned int size, char flash *fmtstr, va_list argptr) *for the other memory models.*

this function is identical to **vsprintf** except that at most **size** (including the null terminator) characters are placed in the character string **str**. The function returns the number of outputed characters.

char *gets(char *str, unsigned char len)

inputs, using **getchar**, the character string **str** terminated by the new line character. The new line character will be replaced with 0. The maximum length of the string is **len**. If **len** characters were read without encountering the new line character, then the string is terminated with 0 and the function ends. The function returns a pointer to **str**.

signed char scanf(char flash *fmtstr [, arg1 address, arg2 address, ...])

formatted text input by scanning, using **getchar**, a series of input fields according to the format specifiers in the **fmtstr** string. The format specifier string **fmtstr** is constant and must be located in FLASH memory. The implementation of **scanf** is a reduced version of the standard C function. This was necessary due to the specific needs of an embedded system and because the full implementation would require a large amount of FLASH memory space. The format specifier string has the following structure:

```
%[width][l]type_char
```

The optional **width** specifier sets the maximal number of characters to read. If the function encounters a whitespace character or one that cannot be converted, then it will continue with the next input field, if present.

The optional 'l' input size modifier specifies that the function argument must be treated as a long int for the 'i', 'd', 'u', 'x' conversion type characters.

The **type_char** conversion type character is used to specify the way the input field will be processed.

The following conversion type characters are supported:

- 'd' - inputs a signed decimal integer in a pointer to int argument;
- 'i' - inputs a signed decimal integer in a pointer to int argument;
- 'u' - inputs an unsigned decimal integer in a pointer to unsigned int argument;
- 'x' - inputs an unsigned hexadecimal integer in a pointer to unsigned int argument;
- 'c' - inputs an ASCII character in a pointer to char argument;
- 's' - inputs an ASCII character string in a pointer to char argument;
- '%' - no input is done, a '%' is stored.

CodeVisionAVR

The function returns the number of successful entries, or -1 on error.

signed char sscanf(char *str, char flash *fmtstr [, arg1 address, arg2 address, ...])

this function is identical to **scanf** except that the formatted text is inputted from the null terminated character string **str**, located in RAM.

In order to reduce program code size, there is the **Project|Configure|C Compiler|Code Generation|(s)scanf Features** option.

It allows linking different versions of the **scanf** and **sscanf** functions, with only the features that are really required by the program.

The following **(s)scanf features** are available:

- **int, width** - the following conversion type characters are supported: 'c', 's', 'i', 'd', 'u', 'x', '%', the width specifier is supported, no input size modifiers are supported
- **long, width** - the following conversion type characters are supported: 'c', 's', 'i', 'd', 'u', 'x', '%' the width specifier is supported, only the 'l' input size modifier is supported.

The more features are selected, the larger is the code size generated for the **scanf** and **sscanf** functions.

The following Standard C Input/Output functions are used for file access on MMC/SD/SD HC FLASH memory cards.

Before using any of these functions, the logical drive that needs to be accessed must be mounted using the **f_mount** function and the appropriate file must be opened using the **f_open** function.

int feof(FIL * fp)

establishes if the end of file was reached during the last file access.

The **fp** pointer must point to a **FIL** type structure, defined in the **ff.h** header file, that was previously initialized using the **f_open** function.

If the end of file was reached, a non-zero value (1) will be returned.
Otherwise, the function will return 0.

int ferror(FIL *fp)

establishes if an error occurred during the last file access.

The **fp** pointer must point to a **FIL** type structure, defined in the **ff.h** header file, that was previously initialized using the **f_open** function.

If an error occurred, a non-zero value (1) will be returned.
Otherwise, the function will return 0.

int fgetc(FIL *fp)

reads a character from a file.

The **fp** pointer must point to a **FIL** type structure, defined in the **ff.h** header file, that was previously initialized using the **f_open** function.

On success the function returns a positive value: an 8bit character in the LSB, the MSB being 0.
In case of error or if the end of file was reached, the function returns the value of the predefined macro **EOF** (-1).

The **ferror** function must be used to establish if an error occurred.

In order to check if the end of file was reached, the **feof** function must be called.

char *fgets(char *str,unsigned int len,FIL *fp)

reads from a file maximum **len-1** characters to the char array pointed by **str**. The read process stops if a new-line '\n' character is encountered or the end of file was reached. The new-line character is also saved in the char string. The string is automatically NULL terminated after the read process is stopped. The **fp** pointer must point to a **FIL** type structure, defined in the **ff.h** header file, that was previously initialized using the **f_open** function.

On success the function returns the same pointer as **str**.
If the end of file was encountered and no characters were read, a NULL pointer is returned. The same happens in case of file access error.
The **ferror** function must be used to establish if an error occurred.
In order to check if the end of file was reached, the **feof** function must be called.

int fputc(char k,FIL* fp)

writes the character **k** to a file.
The **fp** pointer must point to a **FIL** type structure, defined in the **ff.h** header file, that was previously initialized using the **f_open** function.

On success the function returns a positive value which represents the same character as **k**, the MSB being 0.
In case of error the function returns the value of the predefined macro **EOF** (-1).

int fputs(char *str,FIL* fp)

writes to a file the NULL terminated char string, stored in RAM, pointed by **str**. The terminating NULL character is not written to the file.
The **fp** pointer must point to a **FIL** type structure, defined in the **ff.h** header file, that was previously initialized using the **f_open** function.

On success the function returns a positive value (1).
In case of error the function returns the value of the predefined macro **EOF** (-1).

int fputsf(char flash *str,FIL* fp)

writes to a file the NULL terminated char string, stored in FLASH memory, pointed by **str**. The terminating NULL character is not written to the file.
The **fp** pointer must point to a **FIL** type structure, defined in the **ff.h** header file, that was previously initialized using the **f_open** function.

On success the function returns a positive value (1).
In case of error the function returns the value of the predefined macro **EOF** (-1).

int fprintf(FIL *fp, char flash *fmtstr,...)

this function is identical to **printf** except that the formatted text is written to a file.
The **fp** pointer must point to a **FIL** type structure, defined in the **ff.h** header file, that was previously initialized using the **f_open** function.

On success the function returns a positive value: the number of written characters.
In case of error the function returns the value of the predefined macro **EOF** (-1).

int fscanf(FIL *fp, char flash *fmtstr,...)

this function is identical to **scanf** except that the formatted text is read from a file. The **fp** pointer must point to a **FIL** type structure, defined in the **ff.h** header file, that was previously initialized using the **f_open** function.

On success the function returns a positive value: the number of read entries.
In case of error the function returns the value of the predefined macro **EOF** (-1).

4.3 Standard Library Functions

The prototypes for these functions are placed in the file **stdlib.h**, located in the `.INC` subdirectory. This file must be **#include** -ed before using the functions.

unsigned char cabs(signed char x)

returns the absolute value of the byte x.

unsigned int abs(int x)

returns the absolute value of the integer x.

unsigned long labs(long int x)

returns the absolute value of the long integer x.

float fabs(float x)

returns the absolute value of the floating point number x.

int atoi(char *str)

converts the string str to integer.

long int atol(char *str)

converts the string str to long integer.

void itoa(int n, char *str)

converts the integer n to characters in string str.

void ltoa(long int n, char *str)

converts the long integer n to characters in string str.

void ftoa(float n, unsigned char decimals, char *str)

converts the floating point number n to characters in string str. The number is represented with a specified number of decimals.

void ftoe(float n, unsigned char decimals, char *str)

converts the floating point number n to characters in string str. The number is represented as a mantissa with a specified number of decimals and an integer power of 10 exponent (e.g. 12.35e-5).

float atof(char *str)

converts the characters from string str to floating point.

int rand (void)

generates a pseudo-random number between 0 and 32767.

void srand(int seed)

sets the starting value seed used by the pseudo-random number generator in the **rand** function.

void *malloc(unsigned int size)

allocates a memory block in the heap, with the length of size bytes.

On success the function returns a pointer to the start of the memory block, the block being filled with zeroes.

The allocated memory block occupies size+4 bytes in the heap.

This must be taken into account when specifying the **Heap size** in the **Project|Configure|C Compiler|Code Generation** menu.

If there wasn't enough contiguous free memory in the heap to allocate, the function returns a null pointer.

void *calloc(unsigned int num, unsigned int size)

allocates a memory block in the heap for an array of num elements, each element having the size length.

On success the function returns a pointer to the start of the memory block, the block being filled with zeroes.

If there wasn't enough contiguous free memory in the heap to allocate, the function returns a null pointer.

void *realloc(void *ptr, unsigned int size)

changes the size of a memory block allocated in the heap.

The ptr pointer must point to a block of memory previously allocated in the heap.

The size argument specifies the new size of the memory block.

On success the function returns a pointer to the start of the newly allocated memory block, the contents of the previously allocated block being copied to the newly allocated one.

If the newly allocated memory block is larger in size than the old one, the size difference is not filled with zeroes.

If there wasn't enough contiguous free memory in the heap to allocate, the function returns a null pointer.

void free(void *ptr)

frees a memory block allocated in the heap by the malloc, calloc or realloc functions and pointed by the ptr pointer.

After being freed, the memory block is available for new allocation.
If ptr is null then it is ignored.

4.4 Mathematical Functions

The prototypes for these functions are placed in the file **math.h**, located in the **.INC** subdirectory. This file must be **#include** -ed before using the functions.

signed char cmax(signed char a, signed char b)

returns the maximum value of bytes a and b.

int max(int a, int b)

returns the maximum value of integers a and b.

long int lmax(long int a, long int b)

returns the maximum value of long integers a and b.

float fmax(float a, float b)

returns the maximum value of floating point numbers a and b.

signed char cmin(signed char a, signed char b)

returns the minimum value of bytes a and b.

int min(int a, int b)

returns the minimum value of integers a and b.

long int lmin(long int a, long int b)

returns the minimum value of long integers a and b.

float fmin(float a, float b)

returns the minimum value of floating point numbers a and b.

signed char csign(signed char x)

returns -1, 0 or 1 if the byte x is negative, zero or positive.

signed char sign(int x)

returns -1, 0 or 1 if the integer x is negative, zero or positive

signed char lsign(long int x)

returns -1, 0 or 1 if the long integer x is negative, zero or positive.

signed char fsign(float x)

returns -1, 0 or 1 if the floating point number x is negative, zero or positive.

unsigned char isqrt(unsigned int x)

returns the square root of the unsigned integer x.

unsigned int Isqrt(unsigned long x)

returns the square root of the unsigned long integer x.

float sqrt(float x)

returns the square root of the positive floating point number x.

float floor(float x)

returns the smallest integer value of the floating point number x.

float ceil(float x)

returns the largest integer value of the floating point number x.

float fmod(float x, float y)

returns the remainder of x divided by y.

float modf(float x, float *ipart)

splits the floating point number x into integer and fractional components. The fractional part of x is returned as a signed floating point number. The integer part is stored as floating point number at ipart.

float ldexp(float x, int expn)

returns $x * 2^{\text{expn}}$.

float frexp(float x, int *expn)

returns the mantissa and exponent of the floating point number x.

float exp(float x)

returns e^x .

float log(float x)

returns the natural logarithm of the floating point number x.

float log10(float x)

returns the base 10 logarithm of the floating point number x.

float pow(float x, float y)

returns x^y .

float sin(float x)

returns the sine of the floating point number x, where the angle is expressed in radians.

float cos(float x)

returns the cosine of the floating point number x, where the angle is expressed in radians.

float tan(float x)

returns the tangent of the floating point number x, where the angle is expressed in radians.

float sinh(float x)

returns the hyperbolic sine of the floating point number x, where the angle is expressed in radians.

float cosh(float x)

returns the hyperbolic cosine of the floating point number x, where the angle is expressed in radians.

float tanh(float x)

returns the hyperbolic tangent of the floating point number x, where the angle is expressed in radians.

float asin(float x)

returns the arc sine of the floating point number x (in the range $-\pi/2$ to $\pi/2$).
x must be in the range -1 to 1.

float acos(float x)

returns the arc cosine of the floating point number x (in the range 0 to π).
x must be in the range -1 to 1.

float atan(float x)

returns the arc tangent of the floating point number x (in the range $-\pi/2$ to $\pi/2$).

float atan2(float y, float x)

returns the arc tangent of the floating point numbers y/x (in the range $-\pi$ to π).

4.5 String Functions

The prototypes for these functions are placed in the file **string.h**, located in the `.\INC` subdirectory. This file must be **#include** -ed before using the functions.

The string manipulation functions were extended to handle strings located both in RAM and FLASH memories.

char *strcat(char *str1, char *str2)

concatenate the string str2 to the end of the string str1.

char *strcatf(char *str1, char flash *str2)

concatenate the string str2, located in FLASH, to the end of the string str1.

char *strncat(char *str1, char *str2, unsigned char n)

concatenate maximum n characters of the string str2 to the end of the string str1. Returns a pointer to the string str1.

char *strncatf(char *str1, char flash *str2, unsigned char n)

concatenate maximum n characters of the string str2, located in FLASH, to the end of the string str1. Returns a pointer to the string str1.

char *strchr(char *str, char c)

returns a pointer to the first occurrence of the character c in the string str, else a NULL pointer.

char *strrchr(char *str, char c)

returns a pointer to the last occurrence of the character c in the string str, else a NULL pointer.

signed char strpos(char *str, char c)

returns the index to first occurrence of the character c in the string str, else -1.

signed char strrpos(char *str, char c)

returns the index to the last occurrence of the character c in the string str, else -1.

signed char strcmp(char *str1, char *str2)

compares the string str1 with the string str2. Returns <0, 0, >0 according to str1<str2, str1=str2, str1>str2.

signed char strcmpf(char *str1, char flash *str2)

compares the string str1, located in RAM, with the string str2, located in FLASH. Returns <0, 0, >0 according to str1<str2, str1=str2, str1>str2.

signed char strncmp(char *str1, char *str2, unsigned char n)

compares at most n characters of the string str1 with the string str2. Returns <0, 0, >0 according to str1<str2, str1=str2, str1>str2.

CodeVisionAVR

signed char strncmppf(char *str1, char flash *str2, unsigned char n)

compares at most n characters of the string str1, located in RAM, with the string str2, located in FLASH.

Returns <0, 0, >0 according to str1<str2, str1=str2, str1>str2.

char *strcpy(char *dest, char *src)

copies the string src to the string dest.

char *strcpyf(char *dest, char flash *src)

copies the string src, located in FLASH, to the string dest, located in RAM.

Returns a pointer to the string dest.

char *strncpy(char *dest, char *src, unsigned char n)

copies at most n characters from the string src to the string dest (null padding).

Returns a pointer to the string dest.

char *strncpyf(char *dest, char flash *src, unsigned char n)

copies at most n characters from the string src, located in FLASH, to the string dest, located in RAM (null padding).

Returns a pointer to the string dest.

unsigned char strspn(char *str, char *set)

returns the index of the first character, from the string str, that doesn't match a character from the string set.

If all characters from set are in str returns the length of str.

unsigned char strspnf(char *str, char flash *set)

returns the index of the first character, from the string str, located in RAM, that doesn't match a character from the string set, located in FLASH.

If all characters from set are in str returns the length of str.

unsigned char strcspn(char *str, char *set)

searches the string str for the first occurrence of a character from the string set.

If there is a match returns, the index of the character in str.

If there are no matching characters, returns the length of str.

unsigned char strcspnf(char *str, char flash *set)

searches the string str for the first occurrence of a character from the string set, located in FLASH.

If there is a match, returns the index of the character in str.

If there are no matching characters, returns the length of str.

char *strpbrk(char *str, char *set)

searches the string str for the first occurrence of a char from the string set.

If there is a match, returns a pointer to the character in str.

If there are no matching characters, returns a NULL pointer.

char *strpbrkf(char *str, char flash *set)

searches the string str, located in RAM, for the first occurrence of a char from the string set, located in FLASH.

If there is a match, returns a pointer to the character in str.

If there are no matching characters, returns a NULL pointer.

char *strrprbk(char *str, char *set)

searches the string str for the last occurrence of a character from the string set.

If there is a match, returns a pointer to the character in str.

If there are no matching characters, returns a NULL pointer.

char *strrprbkf(char *str, char flash *set)

searches the string str, located in RAM, for the last occurrence of a character from the string set, located in FLASH.

If there is a match, returns a pointer to the character in str.

If there are no matching characters, returns a NULL pointer.

char *strstr(char *str1, char *str2)

searches the string str1 for the first occurrence of the string str2.

If there is a match, returns a pointer to the character in str1 where str2 begins.

If there is no match, returns a NULL pointer.

char *strstrf(char *str1, char flash *str2)

searches the string str1, located in RAM, for the first occurrence of the string str2, located in FLASH.

If there is a match, returns a pointer to the character in str1 where str2 begins.

If there is no match, returns a NULL pointer.

char *strtok(char *str1, char flash *str2)

scans the string str1, located in RAM, for the first token not contained in the string str2, located in FLASH.

The function considers the string str1 as consisting of a sequence of text tokens, separated by spans of one or more characters from the string str2.

The first call to strtok, with the pointer to str1 being different from NULL, returns a pointer to the first character of the first token in str1. Also a NULL character will be written in str1, immediately after the returned token.

Subsequent calls to strtok, with NULL as the first parameter, will work through the string str1 until no more tokens remain. When there are no more tokens, strtok will return a NULL pointer.

unsigned char strlen(char *str)

for the TINY memory model.

returns the length of the string str (in the range 0..255), excluding the null terminator.

unsigned int strlen(char *str)

for the SMALL memory model.

returns the length of the string str (in the range 0..65535), excluding the null terminator.

unsigned int strlenf(char flash *str)

returns the length of the string str located in FLASH, excluding the null terminator.

CodeVisionAVR

void *memcpy(void *dest,void *src, unsigned char n)

for the TINY memory model.

void *memcpy(void *dest,void *src, unsigned int n)

for the SMALL memory model.

Copies n bytes from src to dest. dest must not overlap src, else use **memmove**.
Returns a pointer to dest.

void *memcpyf(void *dest,void flash *src, unsigned char n)

for the TINY memory model.

void *memcpyf(void *dest,void flash *src, unsigned int n)

for the SMALL memory model.

Copies n bytes from src, located in FLASH, to dest. Returns a pointer to dest.

void *memccpy(void *dest,void *src, char c, unsigned char n)

for the TINY memory model.

void *memccpy(void *dest,void *src, char c, unsigned int n)

for the SMALL memory model.

Copies at most n bytes from src to dest, until the character c is copied.
dest must not overlap src.
Returns a NULL pointer if the last copied character was c or a pointer to dest+n+1.

void *memmove(void *dest,void *src, unsigned char n)

for the TINY memory model.

void *memmove(void *dest,void *src, unsigned int n)

for the SMALL memory model.

Copies n bytes from src to dest. dest may overlap src.
Returns a pointer to dest.

void *memchr(void *buf, unsigned char c, unsigned char n)

for the TINY memory model.

void *memchr(void *buf, unsigned char c, unsigned int n)

for the SMALL memory model.

Scans n bytes from buf for byte c.
Returns a pointer to c if found or a NULL pointer if not found.

signed char memcmp(void *buf1,void *buf2, unsigned char n)

for the TINY memory model.

signed char memcmp(void *buf1,void *buf2, unsigned int n)

for the SMALL memory model.

Compares at most n bytes of buf1 with buf2.

Returns <0, 0, >0 according to buf1<buf2, buf1=buf2, buf1>buf2.

signed char memcmprf(void *buf1,void flash *buf2, unsigned char n)

for the TINY memory model.

signed char memcmprf(void *buf1,void flash *buf2, unsigned int n)

for the SMALL memory model.

Compares at most n bytes of buf1, located in RAM, with buf2, located in FLASH.

Returns <0, 0, >0 according to buf1<buf2, buf1=buf2, buf1>buf2.

void *memset(void *buf, unsigned char c, unsigned char n)

for the TINY memory model.

void *memset(void *buf, unsigned char c, unsigned int n)

for the SMALL memory model.

Sets n bytes from buf with byte c. Returns a pointer to buf.

4.6 Variable Length Argument Lists Macros

These macros are defined in the file **stdarg.h**, located in the `.INC` subdirectory. This file must be **#include** -ed before using the macros.

void va_start(argptr, previous_par)

This macro, when used in a function with a variable length argument list, initializes the **argptr** pointer of **va_list** type, for subsequent use by the **va_arg** and **va_end** macros.

The **previous_par** argument must be the name of the function argument immediately preceding the optional arguments.

The **va_start** macro must be called prior to any access using the **va_arg** macro.

type va_arg(argptr, type)

This macro is used to extract successive arguments from the variable length argument list referenced by **argptr**.

type specifies the data type of the argument to extract.

The **va_arg** macro can be called only once for each argument. The order of the parameters in the argument list must be observed.

On the first call **va_arg** returns the first argument after the **previous_par** argument specified in the **va_start** macro. Subsequent calls to **va_arg** return the remaining arguments in succession.

void va_end(argptr)

This macro is used to terminate use of the variable length argument list pointer **argptr**, initialized using the **va_start** macro.

Example:

```
#include <stdarg.h>

/* declare a function with a variable number of arguments */
int sum_all(int nsum, ...)
{
    va_list argptr;
    int i, result=0;

    /* initialize argptr */
    va_start(argptr, nsum);

    /* add all the function arguments after nsum */
    for (i=1; i <= nsum; i++)
        /* add each argument */
        result+=va_arg(argptr, int);

    /* terminate the use of argptr */
    va_end(argptr);

    return result;
}

void main(void)
{
    int s;
    /* calculate the sum of 5 arguments */
    s=sum_all(5, 10, 20, 30, 40, 50);
}
```

4.7 Non-local Jump Functions

These functions can execute a non-local goto.

They are usually used to pass control to an error recovery routine.

The prototypes for the non-local jump functions are placed in the file **setjmp.h**, located in the `.INC` subdirectory. This file must be **#include** -ed before using the functions.

int setjmp(char *env)

This function saves the current CPU state (Y, SP, SREG registers and the current instruction address) in the `env` variable.

The CPU state can then be restored by subsequently calling the **longjmp** function.

Execution is then resumed immediately after the **setjmp** function call.

The **setjmp** function will return 0 when the current CPU state is saved in the `env` variable.

If the function returns a value different from 0, it signals that a **longjmp** function was executed.

In this situation the returned value is the one that was passed as the `retval` argument to the **longjmp** function.

In order to preserve the local variables in the function where `setjmp` is used, these must be declared with the **volatile** attribute.

void longjmp(char *env, int retval)

This function restores the CPU state that was previously saved in the `env` variable by a call to **setjmp**.

The `retval` argument holds the integer non-zero value that will be returned by **setjmp** after the call to **longjmp**. If a 0 value is passed as the `retval` argument then it will be substituted with 1.

In order to facilitate the usage of these functions, the **setjmp.h** header file also contains the definition of the **jmp_buf** data type, which is used when declaring the `env` variables.

Example:

```
#include <mega8515.h>
#include <stdio.h>
#include <setjmp.h>

/* declare the variable used to hold the CPU state */
jmp_buf cpu_state;

void foo(void)
{
    printf("Now we will make a long jump to main()\n\r");
    longjmp(cpu_state,1);
}

/* ATmega8515 clock frequency [Hz] */
#define xtal 4000000L

/* Baud rate */
#define baud 9600

void main(void)
{
    /* this local variable will be preserved after a longjmp */
    volatile int i;
    /* this local variable will not be preserved after a longjmp */
    int j;
```

CodeVisionAVR

```
/* initialize the USART control register
   TX enabled, no interrupts, 8 data bits */
UCSRA=0x00;
UCSRB=0x08;
UCSRC=0x86;

/* initialize the USART's baud rate */
UBRRH=(xtal/16/baud-1) >> 8;
UBRRL=(xtal/16/baud-1) & 0xFF;

if (setjmp(cpu_state)==0)
{
    printf("First call to setjmp\n\r");
    foo();
}
else
    printf("We jumped here from foo()\n\r");
}
```

4.8 BCD Conversion Functions

The prototypes for these functions are placed in the file **bcd.h**, located in the `.INC` subdirectory. This file must be **#include** -ed before using the functions.

unsigned char bcd2bin(unsigned char n)

Converts the number `n` from BCD representation to it's binary equivalent.

unsigned char bin2bcd(unsigned char n)

Converts the number `n` from binary representation to it's BCD equivalent.
The number `n` values must be from 0 to 99.

4.9 Gray Code Conversion Functions

The prototypes for these functions are placed in the file **gray.h**, located in the `.INC` subdirectory. This file must be **#include** -ed before using the functions.

unsigned char gray2binc(unsigned char n)

unsigned char gray2bin(unsigned int n)

unsigned char gray2binl(unsigned long n)

Convert the number `n` from Gray code representation to it's binary equivalent.

unsigned char bin2grayc(unsigned char n)

unsigned char bin2gray(unsigned int n)

unsigned char bin2grayl(unsigned long n)

Convert the number `n` from binary representation to it's Gray code equivalent.

4.10 Memory Access Macros

The memory access macros are defined in the **mem.h** header file, located in the `.INC` subdirectory. This file must be **#include** -ed before using these macros.

pokeb(addr, data)

this macro writes the **unsigned char** data to RAM at address `addr`.

pokew(addr, data)

this macro writes the **unsigned int** data to RAM at address `addr`. The LSB is written at address `addr` and the MSB is written at address `addr+1`.

peekb(unsigned int addr)

this macro reads an **unsigned char** located in RAM at address `addr`.

peekw (unsigned int addr)

this macro reads an **unsigned int** located in RAM at address `addr`. The LSB is read from address `addr` and the MSB is read from address `addr+1`.

4.11 LCD Functions

4.11.1 LCD Functions for displays with up to 2x40 characters

The LCD Functions are intended for easy interfacing between C programs and alphanumeric LCD modules built with the Hitachi HD44780 chip or equivalent.

The prototypes for these functions are placed in the file **lcd.h**, located in the `.\INC` subdirectory. This file must be **#include** -ed before using the functions.

The LCD functions do not yet support the ATxmega chips.

Prior to **#include** -ing the **lcd.h** file, you must declare which microcontroller port is used for communication with the LCD module.

The following LCD formats are supported in **lcd.h**: 1x8, 2x12, 3x12, 1x16, 2x16, 2x20, 4x20, 2x24 and 2x40 characters.

Example:

```
/* the LCD module is connected to PORTC */
#asm
    .equ __lcd_port=0x15
#endasm

/* now you can include the LCD Functions */
#include <lcd.h>
```

The LCD module must be connected to the port bits as follows:

[LCD]	[AVR Port]
RS (pin4) -----	bit 0
RD (pin 5) -----	bit 1
EN (pin 6) -----	bit 2
DB4 (pin 11) ---	bit 4
DB5 (pin 12) ---	bit 5
DB6 (pin 13) ---	bit 6
DB7 (pin 14) ---	bit 7

You must also connect the LCD power supply and contrast control voltage, according to the data sheet.

The low level LCD Functions are:

void _lcd_ready(void)

waits until the LCD module is ready to receive data.

This function must be called prior to writing data to the LCD with the **_lcd_write_data** function.

void _lcd_write_data(unsigned char data)

writes the byte data to the LCD instruction register.

This function may be used for modifying the LCD configuration.

Example:

```
/* enables the displaying of the cursor */
_lcd_ready();
_lcd_write_data(0xe);
```

CodeVisionAVR

void lcd_write_byte(unsigned char addr, unsigned char data);

writes a byte to the LCD character generator or display RAM.

Example:

```
/* LCD user defined characters
Chip: ATmega8515
Memory Model: SMALL
Data Stack Size: 128 bytes

Use an 2x16 alphanumeric LCD connected
to the STK200+ PORTC header as follows:

[LCD]    [STK200+ PORTC HEADER]
1 GND- 9  GND
2 +5V- 10 VCC
3 VLC- LCD HEADER Vo
4 RS - 1  PC0
5 RD - 2  PC1
6 EN - 3  PC2
11 D4 - 5  PC4
12 D5 - 6  PC5
13 D6 - 7  PC6
14 D7 - 8  PC7 */

/* the LCD is connected to PORTC outputs */
#asm
.equ __lcd_port=0x15 ;PORTC
#endasm

/* include the LCD driver routines */
#include <lcd.h>

typedef unsigned char byte;

/* table for the user defined character
   arrow that points to the top right corner */
flash byte char0[8]={
0b10000000,
0b10001111,
0b10000011,
0b10000101,
0b10001001,
0b10010000,
0b10100000,
0b11000000};

/* function used to define user characters */
void define_char(byte flash *pc,byte char_code)
{
byte i,a;
a=(char_code<<3) | 0x40;
for (i=0; i<8; i++) lcd_write_byte(a+,*pc++);
}
```

CodeVisionAVR

```
void main(void)
{
/* initialize the LCD for 2 lines & 16 columns */
lcd_init(16);

/* define user character 0 */
define_char(char0,0);

/* switch to writing in Display RAM */
lcd_gotoxy(0,0);
lcd_putsf("User char 0:");

/* display used defined char 0 */
lcd_putchar(0);

while (1); /* loop forever */
}
```

unsigned char lcd_read_byte(unsigned char addr);

reads a byte from the LCD character generator or display RAM.

The high level LCD Functions are:

unsigned char lcd_init(unsigned char lcd_columns)

initializes the LCD module, clears the display and sets the printing character position at row 0 and column 0. The numbers of columns of the LCD must be specified (e.g. 16). No cursor is displayed. The function returns 1 if the LCD module is detected and 0 if it is not. This is the first function that must be called before using the other high level LCD Functions.

void lcd_clear(void)

clears the LCD and sets the printing character position at row 0 and column 0.

void lcd_gotoxy(unsigned char x, unsigned char y)

sets the current display position at column x and row y. The row and column numbering starts from 0.

void lcd_putchar(char c)

displays the character c at the current display position.

void lcd_puts(char *str)

displays at the current display position the string str, located in RAM.

void lcd_putsf(char flash *str)

displays at the current display position the string str, located in FLASH.

4.11.2 LCD Functions for displays with 4x40 characters

The LCD Functions are intended for easy interfacing between C programs and alphanumeric LCD modules with 4x40 characters, built with the Hitachi HD44780 chip or equivalent. The prototypes for these functions are placed in the file **lcd4x40.h**, located in the .INC subdirectory. This file must be **#include** -ed before using the functions.

The LCD functions do not yet support the ATxmega chips.

Prior to **#include** -ing the **lcd4x40.h** file, you must declare which microcontroller port is used for communication with the LCD module.

Example:

```
/* the LCD module is connected to PORTC */
#asm
    .equ __lcd_port=0x15
#endasm

/* now you can include the LCD Functions */
#include <lcd4x40.h>
```

The LCD module must be connected to the port bits as follows:

[LCD]	[AVR Port]
RS (pin 11) ---	bit 0
RD (pin 10) ---	bit 1
EN1 (pin 9) ----	bit 2
EN2 (pin 15) --	bit 3
DB4 (pin 4) ----	bit 4
DB5 (pin 3) ----	bit 5
DB6 (pin 2) ----	bit 6
DB7 (pin 1) ----	bit 7

You must also connect the LCD power supply and contrast control voltage, according to the data sheet.

The low level LCD Functions are:

void _lcd_ready(void)

waits until the LCD module is ready to receive data. This function must be called prior to writing data to the LCD with the **_lcd_write_data** function.

void _lcd_write_data(unsigned char data)

writes the byte data to the LCD instruction register. This function may be used for modifying the LCD configuration.

Prior calling the low level functions **_lcd_ready** and **_lcd_write_data**, the global variable **_en1_msk** must be set to **LCD_EN1**, respectively **LCD_EN2**, to select the upper, respectively lower half, LCD controller.

Example:

```
/* enables the displaying of the cursor on the upper half
of the LCD */
_en1_msk=LCD_EN1;
_lcd_ready();
_lcd_write_data(0xe);
```

CodeVisionAVR

void lcd_write_byte(unsigned char addr, unsigned char data);

writes a byte to the LCD character generator or display RAM.

unsigned char lcd_read_byte(unsigned char addr);

reads a byte from the LCD character generator or display RAM.

The high level LCD Functions are:

unsigned char lcd_init(void)

initializes the LCD module, clears the display and sets the printing character position at row 0 and column 0. No cursor is displayed.

The function returns 1 if the LCD module is detected and 0 if it is not.

This is the first function that must be called before using the other high level LCD Functions.

void lcd_clear(void)

clears the LCD and sets the printing character position at row 0 and column 0.

void lcd_gotoxy(unsigned char x, unsigned char y)

sets the current display position at column x and row y. The row and column numbering starts from 0.

void lcd_putchar(char c)

displays the character c at the current display position.

void lcd_puts(char *str)

displays at the current display position the string str, located in RAM.

void lcd_putsf(char flash *str)

displays at the current display position the string str, located in FLASH.

4.11.3 LCD Functions for displays connected in 8 bit memory mapped mode

These LCD Functions are intended for easy interfacing between C programs and alphanumeric LCD modules built with the Hitachi HD44780 chip or equivalent.

The LCD is connected to the AVR external data and address buses as an 8 bit peripheral.

This type of connection is used in the Kanda Systems STK200+ and STK300 development boards.

For the LCD connection, please consult the documentation that came with your development board.

The LCD functions do not yet support the ATxmega chips.

These functions can be used only with AVR chips that allow using external memory devices.

The prototypes for these functions are placed in the file **lcdstk.h**, located in the **.INC** subdirectory.

This file must be **#include** -ed before using the functions.

The following LCD formats are supported in **lcdstk.h**: 1x8, 2x12, 3x12, 1x16, 2x16, 2x20, 4x20, 2x24 and 2x40 characters.

The LCD Functions are:

void _lcd_ready(void)

waits until the LCD module is ready to receive data.

This function must be called prior to writing data to the LCD with the **_LCD_RS0** and **_LCD_RS1** macros.

Example:

```
/* enables the displaying of the cursor */
_lcd_ready();
_LCD_RS0=0xe;
```

The **_LCD_RS0**, respectively **_LCD_RS1**, macros are used for accessing the LCD Instruction Register with RS=0, respectively RS=1.

void lcd_write_byte(unsigned char addr, unsigned char data);

writes a byte to the LCD character generator or display RAM.

Example:

```
/* LCD user defined characters

Chip: ATmegaS8515
Memory Model: SMALL
Data Stack Size: 128 bytes

Use an 2x16 alphanumeric LCD connected
to the STK200+ LCD connector */

/* include the LCD driver routines */
#include <lcdstk.h>

typedef unsigned char byte;
```

CodeVisionAVR

```
/* table for the user defined character
   arrow that points to the top right corner */
flash byte char0[8]={
0b10000000,
0b10001111,
0b10000011,
0b10000101,
0b10001001,
0b10010000,
0b10100000,
0b11000000};

/* function used to define user characters */
void define_char(byte flash *pc,byte char_code)
{
byte i,a;
a=(char_code<<3) | 0x40;
for (i=0; i<8; i++) lcd_write_byte(a++,*pc++);
}

void main(void)
{
/* initialize the LCD for 2 lines & 16 columns */
lcd_init(16);

/* define user character 0 */
define_char(char0,0);

/* switch to writing in Display RAM */
lcd_gotoxy(0,0);
lcd_putsf("User char 0:");

/* display used defined char 0 */
lcd_putchar(0);

while (1); /* loop forever */
}
```

unsigned char lcd_read_byte(unsigned char addr);

reads a byte from the LCD character generator or display RAM.

unsigned char lcd_init(unsigned char lcd_columns)

initializes the LCD module, clears the display and sets the printing character position at row 0 and column 0. The numbers of columns of the LCD must be specified (e.g. 16). No cursor is displayed. The function returns 1 if the LCD module is detected and 0 if it is not. This is the first function that must be called before using the other high level LCD Functions.

void lcd_clear(void)

clears the LCD and sets the printing character position at row 0 and column 0.

void lcd_gotoxy(unsigned char x, unsigned char y)

sets the current display position at column x and row y. The row and column numbering starts from 0.

void lcd_putchar(char c)

displays the character c at the current display position.

void lcd_puts(char *str)

displays at the current display position the string str, located in RAM.

void lcd_putsf(char flash *str)

displays at the current display position the string str, located in FLASH.

4.12 I²C Bus Functions

The I²C Functions are intended for easy interfacing between C programs and various peripherals using the Philips I²C bus.

These functions treat the microcontroller as a bus master and the peripherals as slaves.

The prototypes for these functions are placed in the file **i2c.h**, located in the `.\INC` subdirectory. This file must be **#include** -ed before using the functions.

The I²C Functions functions do not yet support the ATxmega chips.

Prior to **#include** -ing the **i2c.h** file, you must declare which microcontroller port and port bits are used for communication through the I²C bus.

Example:

```
/* the I2C bus is connected to PORTB */
/* the SDA signal is bit 3 */
/* the SCL signal is bit 4 */
#asm
    .equ __i2c_port=0x18
    .equ __sda_bit=3
    .equ __scl_bit=4
#endasm

/* now you can include the I2C Functions */
#include <i2c.h>
```

The I²C Functions are:

void i2c_init(void)

this function initializes the I²C bus.

This is the first function that must be called prior to using the other I²C Functions.

unsigned char i2c_start(void)

issues a START condition.

Returns 1 if bus is free or 0 if the I²C bus is busy.

void i2c_stop(void)

issues a STOP condition.

unsigned char i2c_read(unsigned char ack)

reads a byte from the bus.

CodeVisionAVR

The **ack** parameter specifies if an acknowledgement is to be issued after the byte was read. Set **ack** to 0 for no acknowledgement or 1 for acknowledgement.

unsigned char i2c_write(unsigned char data)

writes the byte data to the bus.

Returns 1 if the slave acknowledges or 0 if not.

Example how to access an Atmel 24C02 256 byte I²C EEPROM:

```
/* the I2C bus is connected to PORTB */
/* the SDA signal is bit 3 */
/* the SCL signal is bit 4 */
#asm
    .equ __i2c_port=0x18
    .equ __sda_bit=3
    .equ __scl_bit=4
#endasm

/* now you can include the I2C Functions */
#include <i2c.h>

/* function declaration for delay_ms */
#include <delay.h>

#define EEPROM_BUS_ADDRESS 0xaa

/* read a byte from the EEPROM */
unsigned char eeprom_read(unsigned char address) {
    unsigned char data;
    i2c_start();
    i2c_write(EEPROM_BUS_ADDRESS);
    i2c_write(address);
    i2c_start();
    i2c_write(EEPROM_BUS_ADDRESS | 1);
    data=i2c_read(0);
    i2c_stop();
    return data;
}

/* write a byte to the EEPROM */
void eeprom_write(unsigned char address, unsigned char data) {
    i2c_start();
    i2c_write(EEPROM_BUS_ADDRESS);
    i2c_write(address);
    i2c_write(data);
    i2c_stop();
    /* 10ms delay to complete the write operation */
    delay_ms(10);
}

void main(void) {
    unsigned char i;
    /* initialize the I2C bus */
    i2c_init();
    /* write the byte 55h at address AAh */
    eeprom_write(0xaa,0x55);
    /* read the byte from address AAh */
    i=eeprom_read(0xaa);
    while (1); /* loop forever */
}
```

4.12.1 National Semiconductor LM75 Temperature Sensor Functions

These functions are intended for easy interfacing between C programs and the LM75 I²C bus temperature sensor.

The prototypes for these functions are placed in the file **lm75.h**, located in the `.INC` subdirectory. This file must be **#include** -ed before using the functions.

The I²C bus functions prototypes are automatically **#include** -ed with the **lm75.h**.

Prior to **#include** -ing the **lm75.h** file, you must declare which microcontroller port and port bits are used for communication with the LM75 through the I²C bus.

Example:

```
/* the I2C bus is connected to ATmega8515 PORTB */
/* the SDA signal is bit 3 */
/* the SCL signal is bit 4 */
#asm
    .equ __i2c_port=0x18
    .equ __sda_bit=3
    .equ __scl_bit=4
#endasm

/* now you can include the LM75 Functions */
#include <lm75.h>
```

The LM75 Functions are:

void lm75_init(unsigned char chip, signed char thyst, signed char tos, unsigned char pol)

this function initializes the LM75 sensor chip.

Before calling this function the I²C bus must be initialized by calling the **i2c_init** function.

This is the first function that must be called prior to using the other LM75 Functions.

If more than one chip is connected to the I²C bus, then the function must be called for each one, specifying accordingly the function parameter **chip**.

Maximum 8 LM75 chips can be connected to the I²C bus, their **chip** address can be from 0 to 7.

The LM75 is configured in comparator mode, where it functions like a thermostat.

The O.S. output becomes active when the temperature exceeds the **tos** limit, and leaves the active state when the temperature drops below the **thyst** limit.

Both **thyst** and **tos** are expressed in °C.

pol represents the polarity of the LM75 O.S. output in active state.

If **pol** is 0, the output is active low and if **pol** is 1, the output is active high.

Refer to the LM75 data sheet for more information.

int lm75_temperature_10(unsigned char chip)

this function returns the temperature of the LM75 sensor with the address **chip**.

The temperature is in °C and is multiplied by 10.

A 300ms delay must be present between two successive calls to the **lm75_temperature_10** function.

CodeVisionAVR

Example how to display the temperature of two LM75 sensors with addresses 0 and 1:

```
/* the LM75 I2C bus is connected to ATmega8515 PORTB */
/* the SDA signal is bit 3 */
/* the SCL signal is bit 4 */
#asm
    .equ __i2c_port=0x18
    .equ __sda_bit=3
    .equ __scl_bit=4
#endasm

/* include the LM75 Functions */
#include <lm75.h>

/* the LCD module is connected to ATmega8515 PORTC */
#asm
    .equ __lcd_port=0x15
#endasm

/* include the LCD Functions */
#include <lcd.h>

/* include the prototype for sprintf */
#include <stdio.h>

/* include the prototype for abs */
#include <stdlib.h>

/* include the prototypes for the delay functions */
#include <delay.h>

char display_buffer[33];

void main(void) {
    int t0,t1;

    /* initialize the LCD, 2 rows by 16 columns */
    lcd_init(16);

    /* initialize the I2C bus */
    i2c_init();

    /* initialize the LM75 sensor with address 0 */
    /* thyst=20°C tos=25°C */
    lm75_init(0,20,25,0);

    /* initialize the LM75 sensor with address 1 */
    /* thyst=30°C tos=35°C */
    lm75_init(1,30,35,0);
```

CodeVisionAVR

```
/* temperature display loop */
while (1)
{
    /* read the temperature of sensor #0 *10°C */
    t0=lm75_temperature_10(0);
    /* 300ms delay */
    delay_ms(300);

    /* read the temperature of sensor #1 *10°C */
    t1=lm75_temperature_10(1);
    /* 300ms delay */
    delay_ms(300);

    /* prepare the displayed temperatures */
    /* in the display_buffer */
    sprintf(display_buffer,
    "t0=%-i.%-u°C\n\t1=%-i.%-u°C",
    t0/10,abs(t0%10),0xdf,t1/10,abs(t1%10),0xdf);

    /* display the temperatures */
    lcd_clear();
    lcd_puts(display_buffer);
};
}
```

4.12.2 Maxim/Dallas Semiconductor DS1621 Thermometer/Thermostat Functions

These functions are intended for easy interfacing between C programs and the DS1621 I²C bus thermometer/thermostat.

The prototypes for these functions are placed in the file **ds1621.h**, located in the `.\INC` subdirectory. This file must be **#include** -ed before using the functions.

The I²C bus functions prototypes are automatically **#include** -ed with the **ds1621.h**.

Prior to **#include** -ing the **ds1621.h** file, you must declare which microcontroller port and port bits are used for communication with the DS1621 through the I²C bus.

Example:

```
/* the I2C bus is connected to ATmega8515 PORTB */
/* the SDA signal is bit 3 */
/* the SCL signal is bit 4 */
#asm
    .equ __i2c_port=0x18
    .equ __sda_bit=3
    .equ __scl_bit=4
#endasm

/* now you can include the DS1621 Functions */
#include <ds1621.h>
```

The DS1621 Functions are:

void ds1621_init(unsigned char chip, signed char tlow, signed char thigh, unsigned char pol)

this function initializes the DS1621 chip.

Before calling this function the I²C bus must be initialized by calling the **i2c_init** function.

This is the first function that must be called prior to using the other DS1621 Functions.

If more than one chip is connected to the I²C bus, then the function must be called for each one, specifying accordingly the function parameter **chip**.

Maximum 8 DS1621 chips can be connected to the I²C bus, their **chip** address can be from 0 to 7.

Besides measuring temperature, the DS1621 functions also like a thermostat.

The Tout output becomes active when the temperature exceeds the **thigh** limit, and leaves the active state when the temperature drops below the **tlow** limit.

Both **tlow** and **thigh** are expressed in °C.

pol represents the polarity of the DS1621 Tout output in active state.

If **pol** is 0, the output is active low and if **pol** is 1, the output is active high.

Refer to the DS1621 data sheet for more information.

unsigned char ds1621_get_status(unsigned char chip)

this function reads the contents of the configuration/status register of the DS1621 with address **chip**.

Refer to the DS1621 data sheet for more information about this register.

void ds1621_set_status(unsigned char chip, unsigned char data)

this function sets the contents of the configuration/status register of the DS1621 with address **chip**.

Refer to the DS1621 data sheet for more information about this register.

void ds1621_start(unsigned char chip)

this functions exits the DS1621, with address **chip**, from the power-down mode and starts the temperature measurements and the thermostat.

void ds1621_stop(unsigned char chip)

this functions enters the DS1621, with address **chip**, in power-down mode and stops the temperature measurements and the thermostat.

int ds1621_temperature_10(unsigned char chip)

this function returns the temperature of the DS1621 sensor with the address **chip**. The temperature is in °C and is multiplied by 10.

Example how to display the temperature of two DS1621 sensors with addresses 0 and 1:

```
/* the DS1621 I2C bus is connected to ATmega8515 PORTB */
/* the SDA signal is bit 3 */
/* the SCL signal is bit 4 */
#asm
    .equ __i2c_port=0x18
    .equ __sda_bit=3
    .equ __scl_bit=4
#endasm

/* include the DS1621 Functions */
#include <ds1621.h>

/* the LCD module is connected to ATmega8515 PORTC */
#asm
    .equ __lcd_port=0x15
#endasm

/* include the LCD Functions */
#include <lcd.h>

/* include the prototype for sprintf */
#include <stdio.h>

/* include the prototype for abs */
#include <stdlib.h>

char display_buffer[33];

void main(void) {
    int t0,t1;

    /* initialize the LCD, 2 rows by 16 columns */
    lcd_init(16);
```

CodeVisionAVR

```
/* initialize the I2C bus */
i2c_init();

/* initialize the DS1621 sensor with address 0 */
/* tlow=20°C thigh=25°C */
ds1621_init(0,20,25,0);

/* initialize the DS1621 sensor with address 1 */
/* tlow=30°C thigh=35°C */
ds1621_init(1,30,35,0);

/* temperature display loop */
while (1)
{
    /* read the temperature of DS1621 #0 *10°C */
    t0=ds1621_temperature_10(0);

    /* read the temperature of DS1621 #1 *10°C */
    t1=ds1621_temperature_10(1);

    /* prepare the displayed temperatures */
    /* in the display_buffer */
    sprintf(display_buffer,
            "t0=%-i.%-u°C\nt1=%-i.%-u°C",
            t0/10,abs(t0%10),0xdf,t1/10,abs(t1%10),0xdf);

    /* display the temperatures */
    lcd_clear();
    lcd_puts(display_buffer);
};
}
```

4.12.3 Philips PCF8563 Real Time Clock Functions

These functions are intended for easy interfacing between C programs and the PCF8563 I²C bus real time clock (RTC).

The prototypes for these functions are placed in the file **pcf8563.h**, located in the `.\INC` subdirectory. This file must be **#include** -ed before using the functions.

The I²C bus functions prototypes are automatically **#include** -ed with the **pcf8563.h**.

Prior to **#include** -ing the **pcf8563.h** file, you must declare which microcontroller port and port bits are used for communication with the PCF8563 through the I²C bus.

Example:

```
/* the I2C bus is connected to ATmega8515 PORTB */
/* the SDA signal is bit 3 */
/* the SCL signal is bit 4 */
#asm
    .equ __i2c_port=0x18
    .equ __sda_bit=3
    .equ __scl_bit=4
#endasm
/* now you can include the PCF8563 Functions */
#include <pcf8563.h>
```

The PCF8563 Functions are:

void rtc_init(unsigned char ctrl2, unsigned char clkout, unsigned char timer_ctrl)

this function initializes the PCF8563 chip.

Before calling this function the I²C bus must be initialized by calling the **i2c_init** function.

This is the first function that must be called prior to using the other PCF8563 Functions.

Only one PCF8563 chip can be connected to the I²C bus.

The **ctrl2** parameter specifies the initialization value for the PCF8563 **Control/Status 2** register. The **pcf8563.h** header file defines the following macros which allow the easy setting of the **ctrl2** parameter:

- **RTC_TIE_ON** sets the **Control/Status 2** register bit **TIE** to 1
- **RTC_AIE_ON** sets the **Control/Status 2** register bit **AIE** to 1
- **RTC_TP_ON** sets the **Control/Status 2** register bit **TI/TP** to 1

These macros can be combined using the **|** operator in order to set more bits to 1.

The **clkout** parameter specifies the initialization value for the PCF8563 **CLKOUT Frequency** register. The **pcf8563.h** header file defines the following macros which allow the easy setting of the **clkout** parameter:

- **RTC_CLKOUT_OFF** disables the generation of pulses on the PCF8563 CLKOUT output
- **RTC_CLKOUT_1** generates 1Hz pulses on the PCF8563 CLKOUT output
- **RTC_CLKOUT_32** generates 32Hz pulses on the PCF8563 CLKOUT output
- **RTC_CLKOUT_1024** generates 1024Hz pulses on the PCF8563 CLKOUT output
- **RTC_CLKOUT_32768** generates 32768Hz pulses on the PCF8563 CLKOUT output.

The **timer_ctrl** parameter specifies the initialization value for the PCF8563 **Timer Control** register.

The **pcf8563.h** header file defines the following macros which allow the easy setting of the **timer_ctrl** parameter:

- **RTC_TIMER_OFF** disables the PCF8563 Timer countdown
- **RTC_TIMER_CLK_1_60** sets the PCF8563 Timer countdown clock frequency to 1/60Hz
- **RTC_TIMER_CLK_1** sets the PCF8563 Timer countdown clock frequency to 1Hz
- **RTC_TIMER_CLK_64** sets the PCF8563 Timer countdown clock frequency to 64Hz
- **RTC_TIMER_CLK_4096** sets the PCF8563 Timer countdown clock frequency to 4096Hz.

Refer to the PCF8563 data sheet for more information.

CodeVisionAVR

unsigned char rtc_read(unsigned char address)

this function reads the byte stored in a PCF8563 register at **address**.

void rtc_write(unsigned char address, unsigned char data)

this function stores the byte **data** in the PCF8583 register at **address**.

unsigned char rtc_get_time(unsigned char *hour, unsigned char *min, unsigned char *sec)

this function returns the current time measured by the RTC .

The ***hour**, ***min** and ***sec** pointers must point to the variables that must receive the values of hour, minutes and seconds.

The function return the value 1 if the read values are correct.

If the function returns 0 then the chip supply voltage has dropped below the Vlow value and the time values are incorrect.

Example:

```
/* the I2C bus is connected to ATmega8515 PORTB */
#asm
    .equ __i2c_port=0x18
    .equ __sda_bit=3
    .equ __scl_bit=4
#endasm

#include <pcf8563.h>

void main(void) {
    unsigned char ok,h,m,s;

    /* initialize the I2C bus */
    i2c_init();

    /* initialize the RTC,
       Timer interrupt enabled,
       Alarm interrupt enabled,
       CLKOUT frequency=1Hz
       Timer clock frequency=1Hz */
    rtc_init(RTC_TIE_ON | RTC_AIE_ON,RTC_CLKOUT_1,RTC_TIMER_CLK_1);

    /* read time from the RTC */
    ok=rtc_get_time(&h,&m,&s);

    /* ..... */
}
```

void rtc_set_time(unsigned char hour, unsigned char min, unsigned char sec)

this function sets the current time of the RTC .

The **hour**, **min** and **sec** parameters represent the values of hour, minutes and seconds.

void rtc_get_date(unsigned char *date, unsigned char *month, unsigned *year)

this function returns the current date measured by the RTC .

The ***date**, ***month** and ***year** pointers must point to the variables that must receive the values of day, month and year.

void rtc_set_date(unsigned char date, unsigned char month, unsigned year)

this function sets the current date of the RTC .

void rtc_alarm_off(void)

this function disables the RTC alarm function.

void rtc_alarm_on(void)

this function enables the RTC alarm function.

void rtc_get_alarm(unsigned char *date, unsigned char *hour, unsigned char *min)

this function returns the alarm time and date of the RTC.

The ***date**, ***hour** and ***min** pointers must point to the variables that must receive the values of date, hour and minutes.

void rtc_set_alarm(unsigned char date, unsigned char hour, unsigned char min)

this function sets the alarm time and date of the RTC.

The **date**, **hour** and **min** parameters represent the values of date, hours and minutes.

If **date** is set to 0, then this parameter will be ignored.

After calling this function the alarm will be turned off. It must be enabled using the **rtc_alarm_on** function.

void rtc_set_timer(unsigned char val)

this function sets the countdown value of the PCF8563 Timer.

4.12.4 Philips PCF8583 Real Time Clock Functions

These functions are intended for easy interfacing between C programs and the PCF8583 I²C bus real time clock (RTC).

The prototypes for these functions are placed in the file **pcf8583.h**, located in the `.\INC` subdirectory. This file must be **#include** -ed before using the functions.

The I²C bus functions prototypes are automatically **#include** -ed with the **pcf8583.h**.

Prior to **#include** -ing the **pcf8583.h** file, you must declare which microcontroller port and port bits are used for communication with the PCF8583 through the I²C bus.

Example:

```
/* the I2C bus is connected to ATmega8515 PORTB */
/* the SDA signal is bit 3 */
/* the SCL signal is bit 4 */
#asm
    .equ __i2c_port=0x18
    .equ __sda_bit=3
    .equ __scl_bit=4
#endasm

/* now you can include the PCF8583 Functions */
#include <pcf8583.h>
```

The PCF8583 Functions are:

void rtc_init(unsigned char chip, unsigned char dated_alarm)

this function initializes the PCF8583 chip.

Before calling this function the I²C bus must be initialized by calling the **i2c_init** function.

This is the first function that must be called prior to using the other PCF8583 Functions.

If more than one chip is connected to the I²C bus, then the function must be called for each one, specifying accordingly the function parameter **chip**.

Maximum 2 PCF8583 chips can be connected to the I²C bus, their chip address can be 0 or 1.

The **dated_alarm** parameter specifies if the RTC alarm takes in account both the time and date (**dated_alarm=1**), or only the time (**dated_alarm=0**).

Refer to the PCF8583 data sheet for more information.

After calling this function the RTC alarm is disabled.

unsigned char rtc_read(unsigned char chip, unsigned char address)

this function reads the byte stored in the PCF8583 SRAM.

void rtc_write(unsigned char chip, unsigned char address, unsigned char data)

this function stores the byte **data** in the PCF8583 SRAM.

When writing to the SRAM the user must take in account that locations at addresses 10h and 11h are used for storing the current year value.

unsigned char rtc_get_status(unsigned char chip)

this function returns the value of the PCF8583 control/status register.

By calling this function the global variables **__rtc_status** and **__rtc_alarm** are automatically updated.

The **__rtc_status** variable holds the value of the PCF8583 control/status register.

The **__rtc_alarm** variable takes the value 1 if an RTC alarm occurred.

CodeVisionAVR

void rtc_get_time(unsigned char chip, unsigned char *hour, unsigned char *min, unsigned char *sec, unsigned char *hsec)

this function returns the current time measured by the RTC.

The ***hour**, ***min**, ***sec** and ***hsec** pointers must point to the variables that must receive the values of hour, minutes, seconds and hundreds of a second.

Example:

```
/* the I2C bus is connected to ATmega8515 PORTB */
#asm
    .equ __i2c_port=0x18
    .equ __sda_bit=3
    .equ __scl_bit=4
#endasm

#include <pcf8583.h>

void main(void) {
    unsigned char h,m,s,hs;

    /* initialize the I2C bus */
    i2c_init();

    /* initialize the RTC 0,
       no dated alarm */
    rtc_init(0,0);

    /* read time from RTC 0*/
    rtc_get_time(0, &h, &m, &s, &hs);

    /* ..... */
}
```

void rtc_set_time(unsigned char chip, unsigned char hour, unsigned char min, unsigned char sec, unsigned char hsec)

this function sets the current time of the RTC.

The **hour**, **min**, **sec** and **hsec** parameters represent the values of hour, minutes, seconds and hundreds of a second.

void rtc_get_date(unsigned char chip, unsigned char *date, unsigned char *month, unsigned char *year)

this function returns the current date measured by the RTC.

The ***date**, ***month** and ***year** pointers must point to the variables that must receive the values of day, month and year.

void rtc_set_date(unsigned char chip, unsigned char date, unsigned char month, unsigned char year)

this function sets the current date of the RTC.

void rtc_alarm_off(unsigned char chip)

this function disables the RTC alarm function.

void rtc_alarm_on(unsigned char chip)

this function enables the RTC alarm function.

CodeVisionAVR

void rtc_get_alarm_time(unsigned char chip, unsigned char *hour, unsigned char *min, unsigned char *sec, unsigned char *hsec)

this function returns the alarm time of the RTC.
The ***hour**, ***min**, ***sec** and ***hsec** pointers must point to the variables that must receive the values of hours, minutes, seconds and hundreds of a second.

void rtc_set_alarm_time(unsigned char chip, unsigned char hour, unsigned char min, unsigned char sec, unsigned char hsec)

this function sets the alarm time of the RTC.
The **hour**, **min**, **sec** and **hsec** parameters represent the values of hours, minutes, seconds and hundreds of a second.

void rtc_get_alarm_date(unsigned char chip, unsigned char *date, unsigned char *month)

this function returns the alarm date of the RTC.
The ***day** and ***month** pointers must point to the variables that must receive the values of date and month.

void rtc_set_alarm_date(unsigned char chip, unsigned char date, unsigned char month)

this function sets the alarm date of the RTC.

4.12.5 Maxim/Dallas Semiconductor DS1307 Real Time Clock Functions

These functions are intended for easy interfacing between C programs and the DS1307 I²C bus real time clock (RTC).

The prototypes for these functions are placed in the file **ds1307.h**, located in the `.\INC` subdirectory. This file must be **#include**-ed before using the functions.

The I²C bus functions prototypes are automatically **#include**-ed with the **ds1307.h**.

Prior to **#include**-ing the **ds1307.h** file, you must declare which microcontroller port and port bits are used for communication with the DS1307 through the I²C bus.

Example:

```
/* the I2C bus is connected to Atmega8515 PORTB */
/* the SDA signal is bit 3 */
/* the SCL signal is bit 4 */
#asm
    .equ __i2c_port=0x18
    .equ __sda_bit=3
    .equ __scl_bit=4
#endasm

/* now you can include the DS1307 Functions */
#include <ds1307.h>
```

The DS1307 Functions are:

void rtc_init(unsigned char rs, unsigned char sqwe, unsigned char out)

this function initializes the DS1307 chip.

Before calling this function the I²C bus must be initialized by calling the **i2c_init** function.

This is the first function that must be called prior to using the other DS1307 Functions.

The **rs** parameter specifies the value of the square wave output frequency on the SQW/OUT pin:

- 0 for 1Hz
- 1 for 4096Hz
- 2 for 8192Hz
- 3 for 32768Hz.

If the **sqwe** parameter is set to 1 then the square wave output on the SQW/OUT pin is enabled.

The **out** parameter specifies the logic level on the SQW/OUT pin when the square wave output is disabled (sqwe=0).

Refer to the DS1307 data sheet for more information.

void rtc_get_time(unsigned char *hour, unsigned char *min, unsigned char *sec)

this function returns the current time measured by the RTC.

The ***hour**, ***min** and ***sec** pointers must point to the variables that must receive the values of hours, minutes and seconds.

Example:

```
/* the I2C bus is connected to Atmega8515 PORTB */
/* the SDA signal is bit 3 */
/* the SCL signal is bit 4 */
#asm
    .equ __i2c_port=0x18
    .equ __sda_bit=3
    .equ __scl_bit=4
#endasm
```

CodeVisionAVR

```
#include <ds1307.h>

void main(void) {
    unsigned char h,m,s;

    /* initialize the I2C bus */
    i2c_init();

    /* initialize the DS1307 RTC */
    rtc_init(0,0,0);

    /* read time from the DS1307 RTC */
    rtc_get_time(&h,&m,&s);

    /* ..... */
}
```

void rtc_set_time(unsigned char hour, unsigned char min, unsigned char sec)

this function sets the current time of the RTC.
The **hour**, **min** and **sec** parameters represent the values of hour, minutes and seconds.

void rtc_get_date(unsigned char *date, unsigned char *month, unsigned char *year)

this function returns the current date measured by the RTC.
The ***date**, ***month** and ***year** pointers must point to the variables that must receive the values of date, month and year.

void rtc_set_date(unsigned char date, unsigned char month, unsigned char year)

this function sets the current date of the RTC.

4.13 Maxim/Dallas Semiconductor DS1302 Real Time Clock Functions

These functions are intended for easy interfacing between C programs and the DS1302 real time clock (RTC).

The prototypes for these functions are placed in the file **ds1302.h**, located in the `.\INC` subdirectory. This file must be **#include** -ed before using the functions.

The DS1302 RTC Functions functions do not yet support the ATxmega chips.

Prior to **#include** -ing the **ds1302.h** file, you must declare which microcontroller port and port bits are used for communication with the DS1302.

Example:

```
/* the DS1302 is connected to ATmega8515 PORTB
   the IO signal is bit 3
   the SCLK signal is bit 4
   the RST signal is bit 5 */
#asm
    .equ __ds1302_port=0x18
    .equ __ds1302_io=3
    .equ __ds1302_sclk=4
    .equ __ds1302_rst=5
#endasm

/* now you can include the DS1302 Functions */
#include <ds1302.h>
```

The DS1302 Functions are:

void rtc_init(unsigned char tc_on, unsigned char diodes, unsigned char res)

this function initializes the DS1302 chip.

This is the first function that must be called prior to using the other DS1302 Functions.

If the **tc_on** parameter is set to 1 then the DS1302's trickle charge function is enabled.

The **diodes** parameter specifies the number of diodes used when the trickle charge function is enabled. This parameter can take the value 1 or 2.

The **res** parameter specifies the value of the trickle charge resistor:

- 0 for no resistor
- 1 for a 2k Ω resistor
- 2 for a 4k Ω resistor
- 3 for a 8k Ω resistor.

Refer to the DS1302 data sheet for more information.

unsigned char ds1302_read(unsigned char addr)

this function reads a byte stored at address **addr** in the DS1302 registers or SRAM.

void ds1302_write(unsigned char addr, unsigned char data)

this function stores the byte **data** at address **addr** in the DS1302 registers or SRAM.

void rtc_get_time(unsigned char *hour, unsigned char *min, unsigned char *sec)

this function returns the current time measured by the RTC.

The ***hour**, ***min** and ***sec** pointers must point to the variables that must receive the values of hours, minutes and seconds.

CodeVisionAVR

Example:

```
/* the DS1302 is connected to ATmega8515 PORTB
   the IO signal is bit 3
   the SCLK signal is bit 4
   the RST signal is bit 5 */
#asm
    .equ __ds1302_port=0x18
    .equ __ds1302_io=3
    .equ __ds1302_sclk=4
    .equ __ds1302_rst=5
#endasm

#include <ds1302.h>

void main(void) {
    unsigned char h,m,s;

    /* initialize the DS1302 RTC:
       use trickle charge,
       with 1 diode and 8K resistor */
    rtc_init(1,1,3);

    /* read time from the DS1302 RTC */
    rtc_get_time(&h, &m, &s);

    /* ..... */
}
```

void rtc_set_time(unsigned char hour, unsigned char min, unsigned char sec)

this function sets the current time of the RTC.
The **hour**, **min** and **sec** parameters represent the values of hour, minutes and seconds.

void rtc_get_date(unsigned char *date, unsigned char *month, unsigned char *year)

this function returns the current date measured by the RTC.
The ***date**, ***month** and ***year** pointers must point to the variables that must receive the values of date, month and year.

void rtc_set_date(unsigned char date, unsigned char month, unsigned char year)

this function sets the current date of the RTC.

4.14 1 Wire Protocol Functions

The 1 Wire Functions are intended for easy interfacing between C programs and various peripherals using the Maxim/Dallas Semiconductor 1 Wire protocol.

These functions treat the microcontroller as a bus master and the peripherals as slaves.

The prototypes for these functions are placed in the file **1wire.h**, located in the `.\INC` subdirectory. This file must be **#include** -ed before using the functions.

The 1 Wire Functions functions do not yet support the ATxmega chips.

Prior to **#include** -ing the **1wire.h** file, you must declare which microcontroller port and port bit is used for communication through the 1 Wire protocol.

Example:

```
/* the 1 Wire bus is connected to ATmega8515 PORTB
   the data signal is bit 2 */
#asm
    .equ __w1_port=0x18
    .equ __w1_bit=2
#endasm

/* now you can include the 1 Wire Functions */
#include <1wire.h>
```

Because the 1 Wire Functions require precision time delays for correct operation, the interrupts must be disabled during their execution.

Also it is very important to specify the correct AVR chip **Clock** frequency in the **Project|Configure|C Compiler|Code Generation** menu.

The 1 Wire Functions are:

unsigned char w1_init(void)

this function initializes the 1 Wire devices on the bus.
It returns 1 if there were devices present or 0 if not.

unsigned char w1_read(void)

this function reads a byte from the 1 Wire bus.

unsigned char w1_write(unsigned char data)

this function writes the byte **data** to the 1 Wire bus.
It returns 1 if the write process completed normally or 0 if not.

unsigned char w1_search(unsigned char cmd,void *p)

this function returns the number of devices connected to the 1 Wire bus.
If no devices were detected then it returns 0.
The byte **cmd** represents the Search ROM (F0h), Alarm Search (ECh) for the DS1820/DS18S20, or other similar commands, sent to the 1 Wire device.

The pointer **p** points to an area of RAM where are stored the 8 bytes ROM codes returned by the device. After the eighth byte, the function places a ninth status byte which contains a status bit returned by some 1 Wire devices (e.g. DS2405).

Thus the user must allocate 9 bytes of RAM for each device present on the 1 Wire bus.

If there is more than one device connected to the 1 Wire bus, than the user must first call the **w1_search** function to identify the ROM codes of the devices and to be able to address them at a later stage in the program.

CodeVisionAVR

Example:

```
#include <mega8515.h>

/* specify the Atmega8515 port and bit used for the 1 Wire bus */
#asm
    .equ __w1_port=0x18 ;PORTB
    .equ __w1_bit=2
#endasm

/* include the 1 Wire bus functions prototypes */
#include <1wire.h>

/* include the printf function prototype */
#include <stdio.h>

/* specify the maximum number of devices connected
   to the 1 Wire bus */
#define MAX_DEVICES 8

/* allocate RAM space for the ROM codes & status bit */
unsigned char rom_codes[MAX_DEVICES][9];

/* quartz crystal frequency [Hz] */
#define xtal 4000000L

/* Baud rate */
#define baud 9600

void main(void) {
    unsigned char i,j,devices;

    /* initialize the USART control register
       TX enabled, no interrupts, 8 data bits */
    UCSRA=0x00;
    UCSRB=0x08;
    UCSRC=0x86;

    /* initialize the USART's baud rate */
    UBRRH=(xtal/16/baud-1) >> 8;
    UBRL=(xtal/16/baud-1) & 0xFF;

    /* detect how many DS1820/DS18S20 devices
       are connected to the bus and
       store their ROM codes in the rom_codes array */
    devices=w1_search(0xf0,rom_codes);

    /* display the ROM codes for each detected device */
    printf("%-u DEVICE(S) DETECTED\n\r",devices);
    if (devices) {
        for (i=0;i<devices;i++) {
            printf("DEVICE #%-u ROM CODE IS:", i+1);
            for (j=0;j<8;j++) printf("%-X ",rom_codes[i][j]);
            printf("\n\r");
        };
    };
    while (1); /* loop forever */
}
```

unsigned char w1_crc8(void *p, unsigned char n)

this function returns the 8 bit DOW CRC for a block of bytes with the length **n**, pointed by **p**.

4.14.1 Maxim/Dallas Semiconductor DS1820/DS18S20 Temperature Sensors Functions

These functions are intended for easy interfacing between C programs and the DS1820/DS18S20 1 Wire bus temperature sensors.

The prototypes for these functions are placed in the file **ds1820.h**, located in the `.\INC` subdirectory. This file must be **#include** -ed before using the functions.

The 1 Wire bus functions prototypes are automatically **#include** -ed with the **ds1820.h**.

Prior to **#include** -ing the **ds1820.h** file, you must declare which microcontroller port and port bit are used for communication with the DS1820/DS18S20 through the 1 Wire bus.

Example:

```
/* specify the Atmega8515 port and bit used for the 1 Wire bus */
#asm
    .equ __w1_port=0x18 ;PORTB
    .equ __w1_bit=2
#endasm

/* include the DS1820/DS18S20 functions prototypes */
#include <ds1820.h>
```

The DS1820/DS18S20 functions are:

unsigned char ds1820_read_spd(unsigned char *addr)

this function reads the contents of the SPD for the DS1820/DS18S20 sensor with the ROM code stored in an array of 8 bytes located at address **addr**.

The functions returns the value 1 on succes and 0 in case of error.

If only one DS1820/DS18S20 sensor is used, no ROM code array is necessary and the pointer **addr** must be NULL (0).

The contents of the SPD will be stored in the structure:

```
struct __ds1820_scratch_pad_struct
{
    unsigned char temp_lsb,temp_msb,
                 temp_high,temp_low,
                 res1,res2,
                 cnt_rem,cnt_c,
                 crc;
} __ds1820_scratch_pad;
```

defined in the **ds1820.h** header file.

int ds1820_temperature_10(unsigned char *addr)

this function returns the temperature of the DS1820/DS18S20 sensor with the ROM code stored in an array of 8 bytes located at address **addr**.

The temperature is measured in °C and is multiplied by 10. In case of error the function returns the value -9999.

If only one DS1820/DS18S20 sensor is used, no ROM code array is necessary and the pointer **addr** must be NULL (0).

CodeVisionAVR

If several sensors are used, then the program must first identify the ROM codes for all the sensors. Only after that the **ds1820_temperature_10** function may be used, with the **addr** pointer pointing to the array which holds the ROM code for the needed device.

Example:

```
#include <mega8515.h>

/* specify the Atmega8515 port and bit used for the 1 Wire bus */
#asm
    .equ __w1_port=0x18 ;PORTB
    .equ __w1_bit=2
#endasm

/* include the DS1820/DS18S20 functions prototypes */
#include <ds1820.h>

/* include the printf function prototype */
#include <stdio.h>

/* include the abs function prototype */
#include <stdlib.h>

/* quartz crystal frequency [Hz] */
#define xtal 4000000L

/* Baud rate */
#define baud 9600

/* maximum number of DS1820/DS18S20 connected to the bus */
#define MAX_DEVICES 8

/* DS1820/DS18S20 devices ROM code storage area,
   9 bytes are used for each device
   (see the w1_search function description),
   but only the first 8 bytes contain the ROM code
   and CRC */
unsigned char rom_codes[MAX_DEVICES][9];

main()
{
    unsigned char i, devices;
    int temp;

    /* initialize the USART control register
       TX enabled, no interrupts, 8 data bits */
    UCSRA=0x00;
    UCSRB=0x08;
    UCSRC=0x86;

    /* initialize the USART's baud rate */
    UBRRH=(xtal/16/ baud-1) >> 8;
    UBRL=(xtal/16/ baud-1) & 0xFF;

    /* detect how many DS1820/DS18S20 devices
       are connected to the bus and
       store their ROM codes in the rom_codes array */
    devices=w1_search(0xf0, rom_codes);
}
```

CodeVisionAVR

```
/* display the number */
printf("%-u DEVICE(S) DETECTED\n\r", devices);

/* if no devices were detected then halt */
if (devices==0) while (1); /* loop forever */

/* measure and display the temperature(s) */
while (1)
{
    for (i=0;i<devices;)
    {
        temp=ds1820_temperature_10(&rom_codes[i][0]);
        printf("t%-u=%-i.%-u\x8C\n\r", ++i, temp/10,
            abs(temp%10));
    };
};
}
```

unsigned char ds1820_set_alarm(unsigned char *addr, signed char temp_low, signed char temp_high)

this function sets the low (**temp_low**) and high (**temp_high**) temperature alarms of the DS1820/DS18S20.

In case of success the function returns the value 1, else it returns 0.

The alarm temperatures are stored in both the DS1820/DS18S20's scratchpad RAM and its EEPROM. The ROM code needed to address the device is stored in an array of 8 bytes located at address **addr**. If only one DS1820/DS18S20 sensor is used, no ROM code array is necessary and the pointer **addr** must be NULL (0).

The alarm status for all the DS1820/DS18S20 devices on the 1 Wire bus can be determined by calling the **w1_search** function with the Alarm Search (ECh) command.

Example:

```
#include <mega8515.h>

/* specify the port and bit used for the 1 Wire bus */
#asm
    .equ __w1_port=0x18 ;PORTB
    .equ __w1_bit=2
#endasm

/* include the DS1820/DS18S20 functions prototypes */
#include <ds1820.h>

/* include the printf function prototype */
#include <stdio.h>

/* include the abs function prototype */
#include <stdlib.h>

/* maximum number of DS1820/DS18S20 connected to the bus */
#define MAX_DEVICES 8

/* DS1820/DS18S20 devices ROM code storage area,
   9 bytes are used for each device
   (see the w1_search function description),
   but only the first 8 bytes contain the ROM code and CRC */
unsigned char rom_codes[MAX_DEVICES][9];
```

CodeVisionAVR

```
/* allocate space for ROM codes of the devices
   which generate an alarm */
unsigned char alarm_rom_codes[MAX_DEVICES][9];

#define xtal 4000000L /* quartz crystal frequency [Hz] */
#define baud 9600 /* Baud rate */

main()
{
  unsigned char i, devices;
  int temp;

  /* initialize the USART control register
     TX enabled, no interrupts, 8 data bits */
  UCSRA=0x00;
  UCSRB=0x08;
  UCSRC=0x86;

  /* initialize the USART's baud rate */
  UBRRH=(xtal/16/baud-1) >> 8;
  UBRL=(xtal/16/baud-1) & 0xFF;

  /* detect how many DS1820/DS18S20 devices
     are connected to the bus and
     store their ROM codes in the rom_codes array */
  devices=w1_search(0xf0, rom_codes);

  /* display the number */
  printf("%-u DEVICE(S) DETECTED\n\r", devices);

  /* if no devices were detected then halt */
  if (devices==0) while (1); /* loop forever */

  /* set the temperature alarms for all the devices
     temp_low=25°C temp_high=35°C */
  for (i=0; i<devices; i++)
  {
    printf("INITIALIZING DEVICE #%-u ", i+1);
    if (ds1820_set_alarm(&rom_codes[i][0], 25, 35))
      putsf("OK"); else putsf("ERROR");
  };

  while (1)
  {
    /* measure and display the temperature(s) */
    for (i=0; i<devices; )
    {
      temp=ds1820_temperature_10(&rom_codes[i][0]);
      printf("t%-u=%-i.%-u\x8C\n\r", ++i, temp/10,
        abs(temp%10));
    };

    /* display the number of devices which
       generated an alarm */
    printf("ALARM GENERATED BY %-u DEVICE(S)\n\r",
      w1_search(0xec, alarm_rom_codes));
  };
}
```

Refer to the DS1820/DS18S20 data sheet for more information.

4.14.2 Maxim/Dallas Semiconductor DS18B20 Temperature Sensor Functions

These functions are intended for easy interfacing between C programs and the DS18B20 1 Wire bus temperature sensor.

The prototypes for these functions are placed in the file **ds18b20.h**, located in the `.\INC` subdirectory. This file must be **#include**-ed before using the functions.

The 1 Wire bus functions prototypes are automatically **#include**-ed with the **ds18b20.h**.

Prior to **#include**-ing the **ds18b20.h** file, you must declare which microcontroller port and port bit are used for communication with the DS18B20 through the 1 Wire bus.

Example:

```
/* specify the Atmega8515 port and bit used for the 1 Wire bus */
#asm
    .equ __w1_port=0x18 ;PORTB
    .equ __w1_bit=2
#endasm

/* include the DS18B20 functions prototypes */
#include <ds18b20.h>
```

The DS18B20 functions are:

unsigned char ds18b20_read_spd(unsigned char *addr)

this function reads the contents of the SPD for the DS18B20 sensor with the ROM code stored in an array of 8 bytes located at address **addr**.

The functions returns the value 1 on succes and 0 in case of error.

If only one DS18B20 sensor is used, no ROM code array is necessary and the pointer **addr** must be NULL (0).

The contents of the SPD will be stored in the structure:

```
struct __ds18b20_scratch_pad_struct
{
    unsigned char temp_lsb,temp_msb,
                 temp_high,temp_low,
                 conf_register,
                 res1,
                 res2,
                 res3,
                 crc;
} __ds18b20_scratch_pad;
```

defined in the **ds18b20.h** header file.

unsigned char ds18b20_init(unsigned char *addr,signed char temp_low,signed char temp_high,unsigned char resolution)

this function sets the low (**temp_low**) and high (**temp_high**) temperature alarms and specifies the temperature measurement **resolution** of the DS18B20.

The resolution argument may take the value of one of the following macros defined in the **ds18b20.h** header file:

```
DS18B20_9BIT_RES for 9 bit teperature measurement resolution (0.5°C)
DS18B20_10BIT_RES for 10 bit teperature measurement resolution (0.25°C)
DS18B20_11BIT_RES for 11 bit teperature measurement resolution (0.125°C)
DS18B20_12BIT_RES for 12 bit teperature measurement resolution (0.0625°C)
```

CodeVisionAVR

In case of success the function returns the value 1, else it returns 0.

The alarm temperatures and resolution are stored in both the DS18B20's scratchpad SRAM and its EEPROM.

The ROM code needed to address the device is stored in an array of 8 bytes located at address **addr**. If only one DS18B20 sensor is used, no ROM code array is necessary and the pointer **addr** must be NULL (0).

The alarm status for all the DS18B20 devices on the 1 Wire bus can be determined by calling the **w1_search** function with the Alarm Search (ECh) command.

float ds18b20_temperature(unsigned char *addr)

this function returns the temperature of the DS18B20 sensor with the ROM code stored in an array of 8 bytes located at address **addr**.

The temperature is measured in °C. In case of error the function returns the value -9999.

If only one DS18B20 sensor is used, no ROM code array is necessary and the pointer **addr** must be NULL (0).

Prior on calling the the **ds18b20_temperature** function for the first time, the **ds18b20_init** function must be used to specify the desired temperature measurement resolution.

If more several sensors are used, then the program must first identify the ROM codes for all the sensors.

Only after that the **ds18b20_temperature** function may be used, with the **addr** pointer pointing to the array which holds the ROM code for the needed device.

Example:

```
#include <mega8515.h>

/* specify the Atmega8515 port and bit used for the 1 Wire bus */
#asm
    .equ __w1_port=0x18 ;PORTB
    .equ __w1_bit=2
#endasm

/* include the DS18B20 functions prototypes */
#include <ds18b20.h>

/* include the printf function prototype */
#include <stdio.h>

/* quartz crystal frequency [Hz] */
#define xtal 4000000L

/* Baud rate */
#define baud 9600

/* maximum number of DS18B20 connected to the bus */
#define MAX_DEVICES 8

/* DS18B20 devices ROM code storage area,
   9 bytes are used for each device
   (see the w1_search function description),
   but only the first 8 bytes contain the ROM code
   and CRC */
unsigned char rom_codes[MAX_DEVICES][9];

/* allocate space for ROM codes of the devices
   which generate an alarm */
unsigned char alarm_rom_codes[MAX_DEVICES][9];
```

CodeVisionAVR

```
main()
{
unsigned char i,devices;

/* initialize the USART control register
   TX enabled, no interrupts, 8 data bits */
UCSRA=0x00;
UCSRB=0x08;
UCSRC=0x86;

/* initialize the USART's baud rate */
UBRRH=(xtal/16/baud-1) >> 8;
UBRRL=(xtal/16/baud-1) & 0xFF;

/* detect how many DS18B20 devices
   are connected to the bus and
   store their ROM codes in the rom_codes array */
devices=w1_search(0xf0,rom_codes);

/* display the number */
printf("%-u DEVICE(S) DETECTED\n\r",devices);

/* if no devices were detected then halt */
if (devices==0) while (1); /* loop forever */

/* set the temperature alarms & temperature
   measurement resolutions for all the devices
   temp_low=25°C temp_high=35°C resolution 12bits */
for (i=0;i<devices;i++)
{
printf("INITIALIZING DEVICE #-u ",i+1);
if (ds18b20_init(&rom_codes[i][0],25,35,DS18B20_12BIT_RES))
putsf("OK"); else putsf("ERROR");
};

while (1)
{
/* measure and display the temperature(s) */
for (i=0;i<devices;)
printf("t%u=%+.3f\%xf8C\n\r",i+1,
ds18b20_temperature(&rom_codes[i++][0]));

/* display the number of devices which
   generated an alarm */
printf("ALARM GENERATED BY %-u DEVICE(S)\n\r",
w1_search(0xec,alarm_rom_codes));
};
}
```

Refer to the DS18B20 data sheet for more information.

4.14.3 Maxim/Dallas Semiconductor DS2430 EEPROM Functions

These functions are intended for easy interfacing between C programs and the DS2430 1 Wire bus EEPROM.

The prototypes for these functions are placed in the file **ds2430.h**, located in the `.\INC` subdirectory. This file must be **#include** -ed before using the functions.

The 1 Wire bus functions prototypes are automatically **#include** -ed with the **ds2430.h**.

Prior to **#include** -ing the **ds2430.h** file, you must declare which microcontroller port and port bits are used for communication with the DS2430 through the 1 Wire bus.

Example:

```
/* specify the Atmega8515 port and bit used for the 1 Wire bus */
#asm
    .equ __w1_port=0x18 ;PORTB
    .equ __w1_bit=2
#endasm

/* include the DS2430 functions prototypes */
#include <ds2430.h>
```

The DS2430 functions are:

**unsigned char ds2430_read_block(unsigned char *romcode,unsigned char *dest,
unsigned char addr,unsigned char size);**

this function reads a block of **size** bytes starting from the DS2430 EEPROM memory address **addr** and stores it in the string **dest** located in RAM.

It returns 1 if successful, 0 if not.

The DS2430 device is selected using its ROM code stored in an array of 8 bytes located at address **romcode**.

**unsigned char ds2430_read(unsigned char *romcode,unsigned char addr,
unsigned char *data);**

this function reads a byte from the DS2430 EEPROM memory address **addr** and stores it in the RAM memory location pointed by **data**.

It returns 1 if successful, 0 if not.

The DS2430 device is selected using its ROM code stored in an array of 8 bytes located at address **romcode**.

**unsigned char ds2430_write_block(unsigned char *romcode,
unsigned char *source,unsigned char addr,unsigned char size);**

this function writes a block of **size** bytes, from the string **source**, located in RAM, in the DS2430 EEPROM starting from memory address **addr**.

It returns 1 if successful, 0 if not.

The DS2430 device is selected using its ROM code stored in an array of 8 bytes located at address **romcode**.

**unsigned char ds2430_write(unsigned char *romcode,
unsigned char addr,unsigned char data);**

this function writes the byte **data** at DS2430 EEPROM memory address **addr**.

It returns 1 if successful, 0 if not.

The DS2430 device is selected using its ROM code stored in an array of 8 bytes located at address **romcode**.

CodeVisionAVR

**unsigned char ds2430_read_appreg_block(unsigned char *romcode,
unsigned char *dest,unsigned char addr,unsigned char size);**

this function reads a block of **size** bytes starting from the DS2430 application register address **addr** and stores it in the string **dest** located in RAM.

It returns 1 if successful, 0 if not.

The DS2430 device is selected using it's ROM code stored in an array of 8 bytes located at address **romcode**.

**unsigned char ds2430_write_appreg_block(unsigned char *romcode,
unsigned char *source,unsigned char addr,unsigned char size);**

this function reads a block of **size** bytes starting from the DS2430 application register address **addr** and stores it in the string **dest** located in RAM.

It returns 1 if successful, 0 if not.

The DS2430 device is selected using it's ROM code stored in an array of 8 bytes located at address **romcode**.

If only one DS2430 EEPROM is used, no ROM code array is necessary and the pointer **romcode** must be NULL (0).

If several 1 Wire device are used, then the program must first identify the ROM codes for all the devices. Only after that the DS2430 functions may be used, with the **romcode** pointer pointing to the array which holds the ROM code for the needed device.

Example:

```
/* specify the port and bit used for the 1 Wire bus
```

```
    The DS2430 devices are connected to  
    bit 6 of PORTA of the ATmega8515 as follows:
```

```
[DS2430]      [STK200 PORTA HEADER]  
  1 GND        -   9 GND  
  2 DATA      -   7 PA6
```

```
    All the devices must be connected in parallel
```

```
    AN 4.7k PULLUP RESISTOR MUST BE CONNECTED  
    BETWEEN DATA (PA6) AND +5V !
```

```
*/
```

```
#asm
```

```
    .equ __w1_port=0x1b  
    .equ __w1_bit=6
```

```
#endasm
```

```
/* include the DS2430 functions */
```

```
#include <ds2430.h>  
#include <mega8515.h>  
#include <stdio.h>
```

```
/* DS2430 devices ROM code storage area,  
   9 bytes are used for each device  
   (see the w1_search function description),  
   but only the first 8 bytes contain the ROM code  
   and CRC */
```

```
#define MAX_DEVICES 8
```

```
unsigned char rom_code[MAX_DEVICES][9];
```

CodeVisionAVR

```
char text[]="Hello world!";
char buffer[32];
#define START_ADDR 2

/* ATmega8515 clock frequency [Hz] */
#define xtal 4000000L

/* Baud rate */
#define baud 9600

main() {
unsigned char i,devices;

/* initialize the USART control register
   TX enabled, no interrupts, 8 data bits */
UCSRA=0x00;
UCSRB=0x08;
UCSRC=0x86;

/* initialize the USART's baud rate */
UBRRH=(xtal/16/baud-1) >> 8;
UBRRL=(xtal/16/baud-1) & 0xFF;

/* detect how many 1 Wire devices are present on the bus */
devices=w1_search(0xF0,&rom_code[0][0]);
printf("%-u 1 Wire devices found\n\r",devices);
for (i=0;i<devices;i++)
  /* make sure to select only the DS2430 types
     0x14 is the DS2430 family code */
  if (rom_code[i][0]==DS2430_FAMILY_CODE)
    {
    printf("\n\r");
    /* write text in each DS2430 at START_ADDR */
    if (ds2430_write_block(&rom_code[i][0],
      text,START_ADDR,sizeof(text)))
      {
      printf("Data written OK in DS2430 #%-u!\n\r",i+1);
      /* display the text written in each DS2430 */
      if (ds2430_read_block(&rom_code[i][0],buffer,START_ADDR,
        sizeof(text)))
        printf("Data read OK!\n\rDS2430 #%-u text: %s\n\r",
          i+1,buffer);
      else printf("Error reading data from DS2430 #%-u!\n\r",
        i+1);
      }
    else printf("Error writing data to DS2430 #%-u!\n\r",i+1);
    };
  /* stop */
while (1);
}
```

Refer to the DS2430 data sheet for more information.

4.14.4 Maxim/Dallas Semiconductor DS2433 EEPROM Functions

These functions are intended for easy interfacing between C programs and the DS2433 1 Wire bus EEPROM.

The prototypes for these functions are placed in the file **ds2433.h**, located in the `.\INC` subdirectory. This file must be **#include** -ed before using the functions.

The 1 Wire bus functions prototypes are automatically **#include** -ed with the **ds2433.h**.

Prior to **#include** -ing the **ds2433.h** file, you must declare which microcontroller port and port bits are used for communication with the DS2433 through the 1 Wire bus.

Example:

```
/* specify the Atmega8515 port and bit used for the 1 Wire bus */
#asm
    .equ __w1_port=0x18 ;PORTB
    .equ __w1_bit=2
#endasm

/* include the DS2433 functions prototypes */
#include <ds2433.h>
```

The DS2433 functions are:

**unsigned char ds2433_read_block(unsigned char *romcode,unsigned char *dest,
unsigned int addr,unsigned int size);**

this function reads a block of **size** bytes starting from the DS2433 EEPROM memory address **addr** and stores it in the string **dest** located in RAM.

It returns 1 if successful, 0 if not.

The DS2433 device is selected using its ROM code stored in an array of 8 bytes located at address **romcode**.

**unsigned char ds2433_read(unsigned char *romcode,unsigned int addr,
unsigned char *data);**

this function reads a byte from the DS2433 EEPROM memory address **addr** and stores it in the RAM memory location pointed by **data**.

It returns 1 if successful, 0 if not.

The DS2433 device is selected using its ROM code stored in an array of 8 bytes located at address **romcode**.

**unsigned char ds2433_write_block(unsigned char *romcode,
unsigned char *source,unsigned int addr,unsigned int size);**

this function writes a block of **size** bytes, from the string **source**, located in RAM, in the DS2433 EEPROM starting from memory address **addr**.

It returns 1 if successful, 0 if not.

The DS2433 device is selected using its ROM code stored in an array of 8 bytes located at address **romcode**.

**unsigned char ds2433_write(unsigned char *romcode,unsigned int addr,
unsigned char data);**

this function writes the byte **data** at DS2433 EEPROM memory address **addr**.

It returns 1 if successful, 0 if not.

The DS2433 device is selected using its ROM code stored in an array of 8 bytes located at address **romcode**.

CodeVisionAVR

If only one DS2433 EEPROM is used, no ROM code array is necessary and the pointer **romcode** must be NULL (0).

If several 1 Wire device are used, then the program must first identify the ROM codes for all the devices. Only after that the DS2433 functions may be used, with the **romcode** pointer pointing to the array which holds the ROM code for the needed device.

Example:

```
/* specify the port and bit used for the 1 Wire bus
```

```
    The DS2433 devices are connected to  
    bit 6 of PORTA of the ATmega8515 as follows:
```

```
[DS2433]      [STK200 PORTA HEADER]  
  1 GND        -   9 GND  
  2 DATA      -   7 PA6
```

```
    All the devices must be connected in parallel
```

```
    AN 4.7k PULLUP RESISTOR MUST BE CONNECTED  
    BETWEEN DATA (PA6) AND +5V !
```

```
*/
```

```
#asm
```

```
    .equ __w1_port=0x1b
```

```
    .equ __w1_bit=6
```

```
#endasm
```

```
// test the DS2433 functions
```

```
#include <ds2433.h>
```

```
#include <mega8515.h>
```

```
#include <stdio.h>
```

```
/* DS2433 devices ROM code storage area,  
   9 bytes are used for each device  
   (see the w1_search function description),  
   but only the first 8 bytes contain the ROM code  
   and CRC */
```

```
#define MAX_DEVICES 8
```

```
unsigned char rom_code[MAX_DEVICES][9];
```

```
char text[]="This is a long text to \  
be able to test writing across the \  
scratchpad boundary";
```

```
char buffer[100];
```

```
#define START_ADDR 2
```

```
/* ATmega8515 clock frequency [Hz] */
```

```
#define xtal 4000000L
```

```
/* Baud rate */
```

```
#define baud 9600
```

CodeVisionAVR

```
main() {
unsigned char i,devices;

/* initialize the USART control register
   TX enabled, no interrupts, 8 data bits */
UCSRA=0x00;
UCSRB=0x08;
UCSRC=0x86;

/* initialize the USART's baud rate */
UBRRH=(xtal/16/ baud-1) >> 8;
UBRRL=(xtal/16/ baud-1) & 0xFF;

/* detect how many 1 Wire devices are present on the bus */
devices=w1_search(0xF0,&rom_code[0][0]);
printf("%-u 1 Wire devices found\n\r",devices);

for (i=0;i<devices;i++)
  /* make sure to select only the DS2433 types
     0x23 is the DS2433 family code */
  if (rom_code[i][0]==DS2433_FAMILY_CODE)
  {
  printf("\n\r");
  /* write text in each DS2433 at START_ADDR */
  if (ds2433_write_block(&rom_code[i][0],
    text,START_ADDR,sizeof(text)))
    {
    printf("Data written OK in DS2433 #%-u!\n\r",i+1);
    /* display the text written in each DS2433 */
    if (ds2433_read_block(&rom_code[i][0],buffer,START_ADDR,
      sizeof(text)))
      printf("Data read OK!\n\rDS2433 #%-u text: %s\n\r",
        i+1,buffer);
    else printf("Error reading data from DS2433 #%-u!\n\r",i+1);
    }
  else printf("Error writing data to DS2433 #%-u!\n\r",i+1);
  };
/* stop */
while (1);
}
```

Refer to the DS2433 data sheet for more information.

4.15 SPI Functions

The SPI Functions are intended for easy interfacing between C programs and various peripherals using the SPI bus.

The prototypes for these functions are placed in the file **spi.h**, located in the `.\INC` subdirectory. This file must be **#include** -ed before using the functions.

The SPI functions are:

unsigned char spi(unsigned char data)

this function sends the byte data, simultaneously receiving a byte.

Prior to using the **spi** function, you must configure the SPI Control Register SPCR according to the Atmel Data Sheets.

Because the **spi** function uses polling for SPI communication, there is no need to set the SPI Interrupt Enable Bit SPIE.

For the ATxmega chips the **spi** function use by default the **SPIC** controller on I/O port **PORTC**.

If you wish to use another SPI controller, you must define the `_ATXMEGA_SPI_` and `_ATXMEGA_SPI_PORT_` preprocessor macros prior to **#include** the **spi.h** header file, like in the example below:

```
/* use the ATxmega128A1 SPID for the spi function */
#define _ATXMEGA_SPI_ SPID
#define _ATXMEGA_SPI_PORT_ PORTD

/* use the SPI functions */
#include <spi.h>
```

The `_ATXMEGA_SPI_` and `_ATXMEGA_SPI_PORT_` macros needs to be defined only once in the whole program, as the compiler will treat them like they are globally defined.

For the ATxmega chips the SPI library also contains the following function:

void spi_init(bool master_mode, bool lsb_first, SPI_MODE_t mode, bool clk2x, SPI_PRESCALER_t clock_div, unsigned char ss_pin)

this function initializes the SPI controller and corresponding I/O port as defined by the `_ATXMEGA_SPI_` and `_ATXMEGA_SPI_PORT_` macros.

If the **master_mode** parameter is true, the SPI controller will function in master mode, otherwise it will function in slave mode.

If the **lsb_first** parameter is true, the data byte sent/received on the bus will start with bit 0, otherwise it will start with bit 7.

The **mode** parameter specifies the SPI clock polarity and phase. The **SPI_MODE_t** data type and SPI modes are defined in the header file **xmbits_a1.h**:

```
SPI_MODE_0_gc for SPI mode 0
SPI_MODE_1_gc for SPI mode 1
SPI_MODE_2_gc for SPI mode 2
SPI_MODE_3_gc for SPI mode 3.
```

If the **clk2x** parameter is true, the SPI master will function in double speed mode.

CodeVisionAVR

The `clock_div` parameter specifies the SPI clock prescaler division factor. The `SPI_PRESCALER_t` data type and SPI prescaler values are defined in the header file `xmbits_a1.h`:

`SPI_PRESCALER_DIV4_gc` for System Clock/4
`SPI_PRESCALER_DIV16_gc` for System Clock/16
`SPI_PRESCALER_DIV64_gc` for System Clock/64
`SPI_PRESCALER_DIV128_gc` for System Clock/128.

The `ss_pin` parameter specifies the SPI I/O port pin that is used for SS. Its values are defined in the header file `xmbits_a1.h`.

Example of using the `spi` function for interfacing to an AD7896 ADC:

```
/*
Digital voltmeter using an
Analog Devices AD7896 ADC
connected to an AT90mega8515
using the SPI bus

Chip: AT90mega8515
Memory Model: SMALL
Data Stack Size: 128 bytes
Clock frequency: 4MHz

AD7896 connections to the ATmega8515

[AD7896] [ATmega8515 DIP40]
1 Vin
2 Vref=5V
3 AGND - 20 GND
4 SCLK - 8 SCK
5 SDATA - 7 MISO
6 DGND - 20 GND
7 CONVST- 2 PB1
8 BUSY - 1 PB0

Use an 2x16 alphanumeric LCD connected
to PORTC as follows:

[LCD] [ATmega8515 DIP40]
1 GND- 20 GND
2 +5V- 40 VCC
3 VLC
4 RS - 21 PC0
5 RD - 22 PC1
6 EN - 23 PC2
11 D4 - 25 PC4
12 D5 - 26 PC5
13 D6 - 27 PC6
14 D7 - 28 PC7 */

#asm
.equ __lcd_port=0x15
#endasm
```

CodeVisionAVR

```
#include <lcd.h> // LCD driver routines
#include <spi.h> // SPI driver routine
#include <mega8515.h>
#include <stdio.h>
#include <delay.h>

/* AD7896 reference voltage [mV] */
#define VREF 5000L

/* AD7896 control signals PORTB bit allocation */
#define ADC_BUSY PINB.0
#define NCONVST PORTB.1

/* LCD display buffer */
char lcd_buffer[33];

unsigned read_adc(void)
{
    unsigned result;
    /* start conversion in mode 1, (high sampling performance) */
    NCONVST=0;
    NCONVST=1;
    /* wait for the conversion to complete */
    while (ADC_BUSY);
    /* read the MSB using SPI */
    result=(unsigned) spi(0)<<8;
    /* read the LSB using SPI and combine with MSB */
    result|=spi(0);
    /* calculate the voltage in [mV] */
    result=(unsigned) (((unsigned long) result*VREF)/4096L);
    /* return the measured voltage */
    return result;
}

void main(void)
{
    /* initialize PORTB
       PB.0 input from AD7896 BUSY
       PB.1 output to AD7896 /CONVST
       PB.2 & PB.3 inputs
       PB.4 output (SPI /SS pin)
       PB.5 input
       PB.6 input (SPI MISO)
       PB.7 output to AD7896 SCLK */
    DDRB=0x92;

    /* initialize the SPI in master mode
       no interrupts, MSB first, clock phase negative
       SCK low when idle, clock phase=0
       SCK=fxtal/4 */
    SPCR=0x54;
    SPSR=0x00;

    /* the AD7896 will work in mode 1 (high sampling performance)
       /CONVST=1, SCLK=0 */
    PORTB=2;

    /* initialize the LCD */
    lcd_init(16);
}
```

CodeVisionAVR

```
lcd_putsf("AD7896 SPI bus\nVoltmeter");
delay_ms(2000);
lcd_clear();

/* read and display the ADC input voltage */
while (1)
{
    sprintf(lcd_buffer, "Uadc=%4umV", read_adc());
    lcd_clear();
    lcd_puts(lcd_buffer);
    delay_ms(100);
};
}
```

4.16 Power Management Functions

The Power Management Functions are intended for putting the AVR chip in one of its low power consumption modes.

The prototypes for these functions are placed in the file **sleep.h**, located in the `.\INC` subdirectory. This file must be **#include** -ed before using the functions.

The Power Management Functions are:

void sleep_enable(void)

this function enables entering the low power consumption modes.

void sleep_disable(void)

this function disables entering the low power consumption modes.

It is used to disable accidental entering the low power consumption modes.

void idle(void)

this function puts the AVR chip in the idle mode.

Prior to using this function, the **sleep_enable** function must be invoked to allow entering the low power consumption modes.

In this mode the CPU is stopped, but the Timers/Counters, Watchdog and interrupt system continue operating.

The CPU can wake up from external triggered interrupts as well as internal ones.

void powerdown(void)

this function puts the AVR chip in the powerdown mode.

Prior to using this function, the **sleep_enable** function must be invoked to allow entering the low power consumption modes.

In this mode the external oscillator is stopped.

The AVR can wake up only from an external reset, Watchdog time-out or external level triggered interrupt.

void powersave(void)

this function puts the AVR chip in the powersave mode.

Prior to using this function, the **sleep_enable** function must be invoked to allow entering the low power consumption modes.

This mode is similar to the powerdown mode with some differences, please consult the Atmel Data Sheet for the particular chip that you use.

void standby(void)

this function puts the AVR chip in the standby mode.

Prior to using this function, the **sleep_enable** function must be invoked to allow entering the low power consumption modes.

This mode is similar to the powerdown mode with the exception that the external clock oscillator keeps on running.

Consult the Atmel Data Sheet for the particular chip that you use, in order to see if the standby mode is available for it.

void extended_standby(void)

this function puts the AVR chip in the extended standby mode. Prior to using this function, the **sleep_enable** function must be invoked to allow entering the low power consumption modes. This mode is similar to the powersave mode with the exception that the external clock oscillator keeps on running. Consult the Atmel Data Sheet for the particular chip that you use, in order to see if the standby mode is available for it.

4.17 Delay Functions

These functions are intended for generating delays in C programs. The prototypes for these functions are placed in the file **delay.h**, located in the `.\INC` subdirectory. This file must be **#include** -ed before using the functions. Before calling the functions the interrupts must be disabled, otherwise the delays will be much longer than expected. Also it is very important to specify the correct AVR chip clock frequency in the **Project|Configure|C Compiler|Code Generation** menu.

The functions are:

void delay_us(unsigned int n)

generates a delay of n μ seconds. n must be a constant expression.

void delay_ms(unsigned int n)

generates a delay of n milliseconds. This function automatically resets the watchdog timer every 1ms by generating the **wdr** instruction.

Example:

```
void main(void) {
/* disable interrupts */
#asm("cli")

/* 100 $\mu$ s delay */
delay_us(100);

/* ..... */

/* 10ms delay */
delay_ms(10);

/* enable interrupts */
#asm("sei")

/* ..... */
}
```

4.18 MMC/SD/SD HC FLASH Memory Card Driver Functions

The MMC/SD/SD HC FLASH Memory Card Driver Functions are intended for interfacing between C programs and MMC, SD, SD HC cards using the SPI bus interface.

These low level functions are referenced by the high level **FAT Access Functions**.

The unctions are based on the open source drivers provided by Mr. ChaN from Electronic Lives Mfg. <http://elm-chan.org>

Before using the card driver functions, the I/O port signals employed for communication with the MMC/SD/SD HC card must be configured in the **Project|Configure|C Compiler|Libraries|MMC/SD/SD HC Card** menu.

Note: The MMC/SD/SD HC card driver functions are not re-entrant. They must not be called from interrupt service routines.

The MMC/SD/SD HC card must be connected to the AVR microcontroller using a CD4050 CMOS buffer that will translate the 5V logic signals to 3.3V as needed by the card.

The connection schematic is provided below:

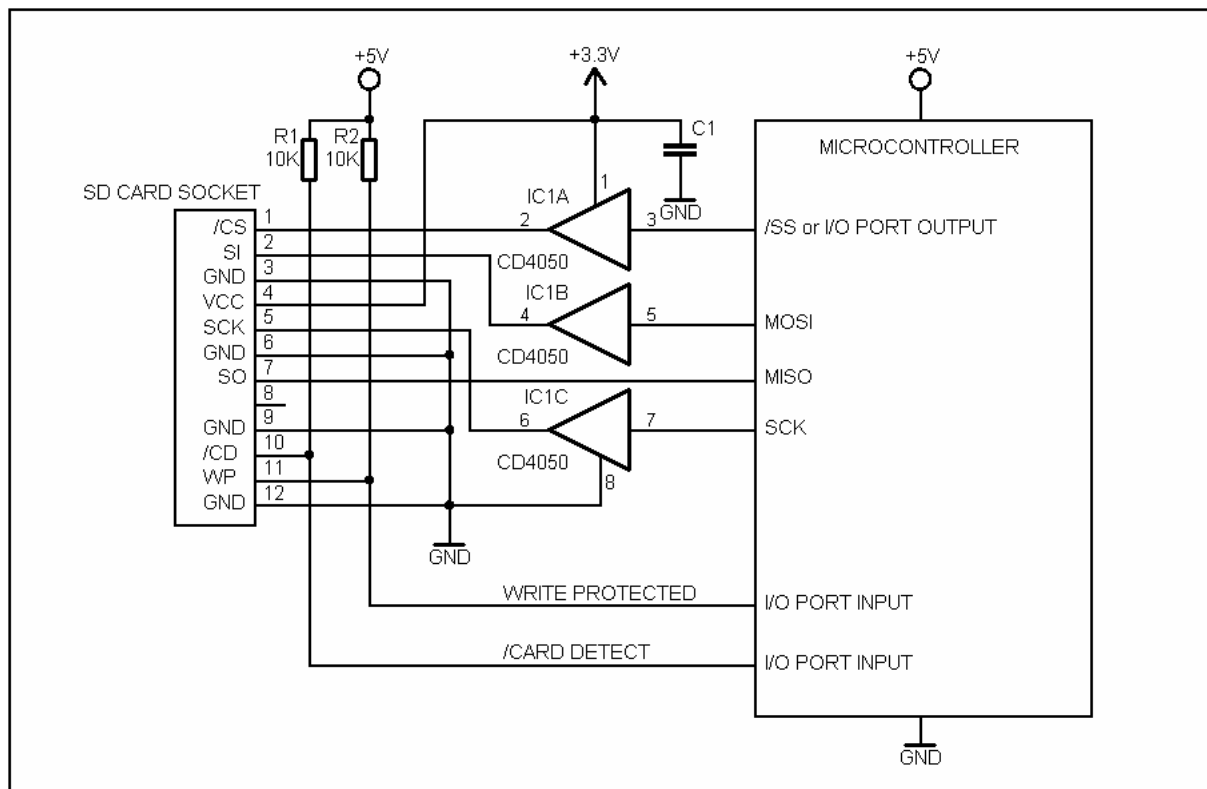

The MMC/SD/SD HC card driver function prototypes, helper type definitions and macros are placed in the header file **sdcard.h**, located in the **.INC** subdirectory. This file must be **#include** -ed before using the functions.

CodeVisionAVR

The MMC/SD/SD HC card driver functions are:

void disk_timerproc (void)

is a low level timing function that must be called every 10ms by a Timer interrupt.

Note: It is mandatory to ensure that this function is called every 10ms in your program. Otherwise the MMC/SD/SD HC card driver functions will lock in an endless loop when testing for disk operations timeout.

Example:

```
/* ATmega128 I/O register definitions */
#include <mega128.h>
/* MMC/SD/SD HC card support */
#include <sdcard.h>

/* Timer1 overflow interrupt frequency [Hz] */
#define T1_OVF_FREQ 100
/* Timer1 clock prescaler value */
#define T1_PRESC 1024L
/* Timer1 initialization value after overflow */
#define T1_INIT (0x1000L-(MCU_CLOCK_FREQUENCY/(T1_PRESC*T1_OVF_FREQ)))

/* 100Hz timer interrupt generated by ATmega128 Timer1 overflow */
interrupt [TIM1_OVF] void timer_comp_isr(void)
{
    /* re-initialize Timer1 */
    TCNT1H=T1_INIT>>8;
    TCNT1L=T1_INIT&0xFF;
    /* card access low level timing function */
    disk_timerproc();

    /* the rest of the interrupt service routine */
    /* .... */

}

void main(void)
{
    /* initialize Timer1 overflow interrupts in Mode 0 (Normal) */
    TCCR1A=0x00;
    /* clkio/1024 */
    TCCR1B=(1<<CS12)|(1<<CS10);
    /* timer overflow interrupts will occur with 100Hz frequency */
    TCNT1H=T1_INIT>>8;
    TCNT1L=T1_INIT&0xFF;
    /* enable Timer1 overflow interrupt */
    TIMSK=1<<TOIE1;
    /* globally enable interrupts */
    #asm("sei")

    /* the rest of the program */
    /* .... */

    while(1)
    {
        /* .... */
    }
}
```

CodeVisionAVR

unsigned char disk_initialize(unsigned char drv)

performs the initialization, including the SPI bus interface and I/O ports, of a physical drive located on a MMC, SD or SD HC card.

Parameters:

drv represents the drive number. Drive numbering starts with 0.

Return value:

The function returns 1 byte containing the disk status flags, specified by the following macros defined in **sdcard.h**:

- **STA_NOINIT** (=0x01, bit 0 of function result) Disk drive not initialized. This flag is set after microcontroller reset, card removal or when the **disk_initialize** function has failed.
- **STA_NODISK** (=0x02, bit 1 of function result) This flag is set if no card is inserted in the socket.
- **STA_PROTECT** (=0x04, bit 2 of function result) Card is write protected. If the **STA_NODISK** flag is also set, the **STA_PROTECT** flag is not valid.

On success, the function returns 0, which means all status flags are reset.

Note: For the MMC/SD/SD HC card driver using the SPI interface, the **drv** parameter must be always 0, otherwise the function will return with the **STA_NOINIT** flag set.

Example:

```
/* ATmega128 I/O register definitions */
#include <mega128.h>
/* MMC/SD/SD HC card support */
#include <sdcard.h>
/* delay functions */
#include <delay.h>

/* the LCD is connected to PORTC outputs */
#asm
.equ __lcd_port=0x15 ;PORTC
#endasm
/* include the LCD driver routines */
#include <lcd.h>

/* Timer1 overflow interrupt frequency [Hz] */
#define T1_OVF_FREQ 100
/* Timer1 clock prescaler value */
#define T1_PRESC 1024L
/* Timer1 initialization value after overflow */
#define T1_INIT (0x10000L-(MCU_CLOCK_FREQUENCY/(T1_PRESC*T1_OVF_FREQ)))
```

CodeVisionAVR

```
/* 100Hz timer interrupt generated by ATmega128 Timer1 overflow */
interrupt [TIM1_OVF] void timer_comp_isr(void)
{
/* re-initialize Timer1 */
TCNT1H=T1_INIT>>8;
TCNT1L=T1_INIT&0xFF;
/* card access low level timing function */
disk_timerproc();

/* the rest of the interrupt service routine */
/* .... */

}

void main(void)
{
unsigned char disk_status;

/* initialize Timer1 overflow interrupts in Mode 0 (Normal) */
TCCR1A=0x00;
/* clkio/1024 */
TCCR1B=(1<<CS12)|(1<<CS10);
/* timer overflow interrupts will occur with 100Hz frequency */
TCNT1H=T1_INIT>>8;
TCNT1L=T1_INIT&0xFF;
/* enable Timer1 overflow interrupt */
TIMSK=1<<TOIE1;
/* initialize the LCD, 16 characters/line */
lcd_init(16);
/* globally enable interrupts */
#asm("sei")
/* initialize SPI interface and card driver */
disk_status=disk_initialize(0);
/* clear the LCD */
lcd_clear();
/* display disk initialization result on the LCD */
if (disk_status & STA_NOINIT) lcd_puts("Disk init failed");
else
if (disk_status & STA_NODISK) lcd_puts("Card not present");
else
if (disk_status & STA_PROTECT) lcd_puts("Card write\nprotected");
/* all status flags are 0, disk initialization OK */
else lcd_puts("Init OK");
/* wait 2 seconds */
delay_ms(2000);

/* the rest of the program */
/* .... */

while(1)
{
/* .... */

}
}
```

CodeVisionAVR

unsigned char disk_status(unsigned char drv)

returns the current disk status of a physical drive located on a MMC, SD or SD HC card.

Parameters:

drv represents the drive number. Drive numbering starts with 0.

Return value:

The function returns 1 byte containing the disk status flags, specified by the following macros defined in **sdcard.h**:

- **STA_NOINIT** (=0x01, bit 0 of function result) Disk drive not initialized. This flag is set after microcontroller reset, card removal or when the **disk_initialize** function has failed.
- **STA_NODISK** (=0x02, bit 1 of function result) This flag is set if no card is inserted in the socket.
- **STA_PROTECT** (=0x04, bit 2 of function result) Card is write protected. If the **STA_NODISK** flag is also set, the **STA_PROTECT** flag is not valid.

On success, the function returns 0, which means all status flags are reset.

Note: For the MMC/SD/SD HC card driver using the SPI interface, the **drv** parameter must be always 0, otherwise the function will return with the **STA_NOINIT** flag set.

The **DRESULT** enumeration data type is defined in **sdcard.h**:

```
typedef enum
{
    RES_OK=0,          /* 0: Successful */
    RES_ERROR,        /* 1: R/W Error */
    RES_WRPRT,        /* 2: Write Protected */
    RES_NOTRDY,       /* 3: Not Ready */
    RES_PARERR        /* 4: Invalid Parameter */
} DRESULT;
```

It is used for returning the result of the following driver functions:

DRESULT disk_read (unsigned char drv, unsigned char* buff, unsigned long sector, unsigned char count)

reads sectors from a physical drive.

Parameters:

drv represents the drive number. Drive numbering starts with 0.

buff points to the char array where read data will be stored.

sector represents the Logical Block Address number of the first sector to be read.

count represents the number of sectors to be read (1..255).

Return value:

- RES_OK - success
- RES_ERROR - a write error occurred
- RES_WRPRT - the MMC/SD/SD HC card is write protected
- RES_NOTRDY - the disk drive has not been initialized
- RES_PARERR - invalid parameters were passed to the function.

Note: For the MMC/SD/SD HC card driver using the SPI interface, the **drv** parameter must be always 0, otherwise the function will return with the STA_NOINIT flag set.

DRESULT disk_write (unsigned char drv, unsigned char* buff, unsigned long sector, unsigned char count)

writes sectors to a physical drive.

Parameters:

drv represents the drive number. Drive numbering starts with 0.
buff points to the char array where the data to be written is stored.
sector represents the Logical Block Address number of the first sector to be written.
count represents the number of sectors to be written (1..255).

Return value:

- RES_OK - success
- RES_ERROR - a write error occurred
- RES_WRPRT - the SD/SD HC card is write protected
- RES_NOTRDY - disk drive has not been initialized
- RES_PARERR - invalid parameters were passed to the function.

Note: For the MMC/SD/SD HC card driver using the SPI interface, the **drv** parameter must be always 0, otherwise the function will return with the STA_NOINIT flag set.

DRESULT disk_ioctl (unsigned char drv, unsigned char ctrl, void* buff)

this function is used for controlling MMC/SD/SD HC card specific features and other disk functions.

Parameters

drv represents the drive number. Drive numbering starts with 0.
ctrl specifies the command code.
buff points to the buffer that will hold function results depending on the command code. When not used, a NULL pointer must be passed as parameter.

Return value:

- RES_OK - success
- RES_ERROR - an error occurred
- RES_NOTRDY - the disk drive has not been initialized
- RES_PARERR - invalid parameters were passed to the function.

Note: For the MMC/SD/SD HC card driver using the SPI interface, the **drv** parameter must be always 0, otherwise the function will return with the STA_NOINIT flag set.

CodeVisionAVR

The following **ctrl** command codes, specified by the macros defined in the **sdcard.h** header file, can be issued to the **disk_ioctl** function:

- **CTRL_SYNC** - wait until the disk drive has finished the write process. The **buff** pointer must be NULL.
- **GET_SECTOR_SIZE** - returns the size of the drive's sector. The **buff** pointer must point to a 16bit **unsigned int** variable, that will contain the sector size. For MMC/SD/SD HC cards the returned sector size will be 512 bytes.
- **GET_SECTOR_COUNT** - returns the total number of sectors on the drive. The **buff** pointer must point to a 32bit **unsigned long int** variable, that will contain the sector count.
- **GET_BLOCK_SIZE** - returns the erase block size of the drive's memory array in sectors count. The **buff** pointer must point to a 32bit **unsigned long int** variable, that will contain the block size. If the erase block size is not known, the returned value will be 1.

Example:

```
/* ATmega128 I/O register definitions */
#include <mega128.h>
/* MMC/SD/SD HC card support */
#include <sdcard.h>
/* delay functions */
#include <delay.h>
/* sprintf */
#include <stdio.h>

/* the LCD is connected to PORTC outputs */
#asm
.equ __lcd_port=0x15 ;PORTC
#endasm

/* include the LCD driver routines */
#include <lcd.h>

/* Timer1 overflow interrupt frequency [Hz] */
#define T1_OVF_FREQ 100
/* Timer1 clock prescaler value */
#define T1_PRESC 1024L
/* Timer1 initialization value after overflow */
#define T1_INIT (0x10000L-(MCU_CLOCK_FREQUENCY_/(T1_PRESC*T1_OVF_FREQ)))

/* 100Hz timer interrupt generated by ATmega128 Timer1 overflow */
interrupt [TIM1_OVF] void timer_comp_isr(void)
{
/* re-initialize Timer1 */
TCNT1H=T1_INIT>>8;
TCNT1L=T1_INIT&0xFF;
/* card access low level timing function */
disk_timerproc();

/* the rest of the interrupt service routine */
/* .... */
}
```

CodeVisionAVR

```
void main(void)
{
char display_buffer[64]; /* buffer used by sprintf */
unsigned char disk_status;
unsigned int sector_size;
unsigned long int sector_count;

/* initialize Timer1 overflow interrupts in Mode 0 (Normal) */
TCCR1A=0x00;
/* clkio/1024 */
TCCR1B=(1<<CS12)|(1<<CS10);
/* timer overflow interrupts will occur with 100Hz frequency */
TCNT1H=T1_INIT>>8;
TCNT1L=T1_INIT&0xFF;
/* enable Timer1 overflow interrupt */
TIMSK=1<<TOIE1;
/* initialize the LCD */
lcd_init(16);
/* globally enable interrupts */
#asm("sei")
/* initialize SPI interface and card driver */
disk_status=disk_initialize(0);
/* clear the LCD */
lcd_clear();
/* display disk initialization result on the LCD */
if (disk_status & STA_NOINIT) lcd_puts("Disk init failed");
else
if (disk_status & STA_NODISK) lcd_puts("Card not present");
else
if (disk_status & STA_PROTECT) lcd_puts("Card write\nprotected");
/* all status flags are 0, disk initialization OK */
else
{
lcd_puts("Init OK");
/* wait 2 seconds */
delay_ms(2000);
/* clear the LCD */
lcd_clear();
/* get the sector size */
if (disk_ioctl(0,GET_SECTOR_SIZE,&sector_size)==RES_OK)
{
/* sector size read OK, display it */
sprintf(display_buffer,"Sector size=%u",sector_size);
lcd_puts(display_buffer);
/* wait 2 seconds */
delay_ms(2000);
/* clear the LCD */
lcd_clear();
/* get the sector count */
if (disk_ioctl(0,GET_SECTOR_COUNT,&sector_count)==RES_OK)
{
/* sector count read OK, display it */
sprintf(display_buffer,"Sector count=%lu",sector_count);
lcd_puts(display_buffer);
}
else lcd_puts("Error reading\nsector count");
}
else lcd_puts("Error reading\nsector size");
}
}
```

CodeVisionAVR

```
/* wait 2 seconds */
delay_ms(2000);

/* the rest of the program */
/* .... */

while(1)
{
    /* .... */

}
}
```

Note: When compiling the above example, make sure that the **(s)printf Features** option in the **Project|Configure|C Compiler|Code Generation** menu will be set to: **long, width**. This will ensure that the unsigned long int **sector_count** variable will be displayed correctly by the **sprintf** function.

4.19 FAT Access Functions

These functions are intended for high level data access to MMC/SD/SD HC FLASH memory cards formatted using the FAT12, FAT16 or FAT32 standards.

The FAT access functions are based on FATFS open source library by Mr. ChaN from Electronic Lives Mfg. <http://elm-chan.org>

The FAT access function prototypes, helper type definitions and macros are placed in the header file **ff.h**, located in the `.\INC` subdirectory. This file must be **#include** -ed before using the functions.

The FAT access functions call the low level **MMC/SD/SD HC Card Driver** functions, so the I/O port signals employed for communication with the MMC/SD/SD HC card must be configured in the **Project|Configure|C Compiler|Libraries|MMC/SD/SD HC Card** menu.

Notes:

- The FAT access functions are not re-entrant. They must not be called from interrupt service routines.
- Currently the FAT access functions support only the DOS short 8.3 file name format. Long file names are not supported.
- The file/directory names are encoded using 8bit ASCII, unicode characters are not supported.
- Before being accessed using the FAT functions, the MMC/SD/SD HC card must be partitioned and formatted to FAT12, FAT16 or FAT32 system on a PC.

The following helper data types are defined in **ff.h**:

- The **FRESULT** type is used for returning the result of the FAT access functions:

```
typedef enum
{
    FR_OK = 0,                /* 0 */
    FR_DISK_ERR,             /* 1 */
    FR_INT_ERR,              /* 2 */
    FR_NOT_READY,            /* 3 */
    FR_NO_FILE,              /* 4 */
    FR_NO_PATH,              /* 5 */
    FR_INVALID_NAME,         /* 6 */
    FR_DENIED,               /* 7 */
    FR_EXIST,                /* 8 */
    FR_INVALID_OBJECT,       /* 9 */
    FR_WRITE_PROTECTED,     /* 10 */
    FR_INVALID_DRIVE,        /* 11 */
    FR_NOT_ENABLED,          /* 12 */
    FR_NO_FILESYSTEM,        /* 13 */
    FR_MKFS_ABORTED,         /* 14 */
    FR_TIMEOUT                /* 15 */
} FRESULT;
```

CodeVisionAVR

- The **FATFS** type structure is used for holding the work area associated with each logical drive volume:

```
typedef struct _FATFS_  
{  
    unsigned char    fs_type;    /* FAT sub type */  
    unsigned char    drive;     /* Physical drive number */  
    unsigned char    csize;     /* Number of sectors per cluster */  
    unsigned char    n_fats;    /* Number of FAT copies */  
    unsigned char    wflag;     /* win[] dirty flag (1:must be written  
back) */  
    unsigned short   id;        /* File system mount ID */  
    unsigned short   n_rootdir; /* Number of root directory entries (0  
on FAT32) */  
    unsigned char    fsi_flag;  /* fsinfo dirty flag (1:must be written  
back) */  
    unsigned long    last_clust; /* Last allocated cluster */  
    unsigned long    free_clust; /* Number of free clusters */  
    unsigned long    fsi_sector; /* fsinfo sector */  
    unsigned long    cdir;      /* Current directory (0:root)*/  
    unsigned long    sects_fat;  /* Sectors per fat */  
    unsigned long    max_clust;  /* Maximum cluster# + 1. Number of  
clusters is max_clust - 2 */  
    unsigned long    fatbase;    /* FAT start sector */  
    unsigned long    dirbase;    /* Root directory start sector  
(Cluster# on FAT32) */  
    unsigned long    database;   /* Data start sector */  
    unsigned long    winsect;    /* Current sector appearing in the  
win[] */  
    unsigned char    win[512];   /* Disk access window for Directory/FAT  
*/  
} FATFS;
```

A **FATFS** type object is allocated by the **f_mount** function for each logical drive.

- The **FIL** type structure is used to hold the state of an open file:

```
typedef struct _FIL_  
{  
    FATFS*    fs;                /* Pointer to the owner file system  
object */  
    unsigned short   id;        /* Owner file system mount ID */  
    unsigned char    flag;      /* File status flags */  
    unsigned char    csect;     /* Sector address in the cluster */  
    unsigned long    fptr;      /* File R/W pointer */  
    unsigned long    fsize;     /* File size */  
    unsigned long    org_clust; /* File start cluster */  
    unsigned long    curr_clust; /* Current cluster */  
    unsigned long    dsect;     /* Current data sector */  
    unsigned long    dir_sect;  /* Sector containing the directory  
entry */  
    unsigned char*   dir_ptr;   /* Pointer to the directory entry in  
the window */  
    unsigned char    buf[512]; /* File R/W buffer */  
} FIL;
```

This structure is initialized by the **f_open** and discarded by the **f_close** functions.

CodeVisionAVR

- The **FILINFO** type structure is used to hold the information returned by the **f_stat** and **f_readdir** functions:

```
typedef struct _FILINFO_
{
    unsigned long    fsize;        /* File size */
    unsigned short   fdate;        /* Last modified date */
    unsigned short   ftime;        /* Last modified time */
    unsigned char    fattrib;      /* Attribute */
    char    fname[13]; /* Short file name (DOS 8.3 format) */
} FILINFO;
```

The **fdate** structure member indicates the date when the file was modified or the directory was created.

It has the following format:

- bits 0:4 - Day: 1...31
- bits 5:8 - Month: 1...12
- bits 9:15 - Year starting with 1980: 0...127

The **ftime** structure member indicates the time when the file was modified or the directory was created.

It has the following format:

- bits 0:4 - Second/2: 0...29
- bits 5:10 - Minute: 0...59
- bits 11:15 - Hour: 0...23

The **fattrib** structure member indicates the file or directory attributes combination defined by the following macros:

- AM_RDO - Read Only attribute
- AM_HID - Hidden attribute
- AM_SYS - System attribute
- AM_VOL - Volume attribute
- AM_DIR - Directory attribute
- AM_ARC - Archive attribute
- AM_MASK - Mask of all defined attributes.

- The **DIR** type structure is used for holding directory information returned by the **f_opendir** and **f_readdir** functions:

```
typedef struct _DIR_
{
    FATFS*    fs;        /* Pointer to the owner file system object
*/
    unsigned short   id;        /* Owner file system mount ID */
    unsigned short   index;    /* Current read/write index number */
    unsigned long    sclust;    /* Table start cluster (0:Static table) */
    unsigned long    clust;    /* Current cluster */
    unsigned long    sect;     /* Current sector */
    unsigned char*   dir;      /* Pointer to the current SFN entry in the
win[] */
    unsigned char*   fn;       /* Pointer to the SFN (in/out)
{file[8],ext[3],status[1]} */
} DIR;
```

CodeVisionAVR

The FAT access functions require the presence of a Real Time Clock in the system, in order to be able to set the time stamp of files or directories.

The following pointers to functions, that allow reading the time and date from the Real Time Clock, are declared in the **ff.h** header file:

void (*prtc_get_time) (unsigned char *hour, unsigned char *min, unsigned char *sec)

pointer to a Real Time Clock function used for reading time.

void (*prtc_get_date) (unsigned char *date, unsigned char *month, unsigned int *year)

pointer to a Real Time Clock function used for reading date.

On program startup these pointers need to be initialized to point to the appropriate RTC functions, like in the following example:

```
/* FAT on MMC/SD/SD HC card support */
#include <ff.h>

/* PCF8563 RTC functions*/
#include <PCF8563.h>

/* The PCF8563 RTC on the I2C bus is connected to ATmega128 PORTD
   SDA - PORTD.1
   SCL - PORTD.0
*/
#asm
    .equ __i2c_port=0x12
    .equ __sda_bit=1
    .equ __scl_bit=0
#endasm

void main(void)
{
    /* init the PCF8563 RTC */
    rtc_init(0,RTC_CLKOUT_OFF,RTC_TIMER_OFF);

    /* init the pointer to the RTC function used for reading time */
    prtc_get_time=
        (void (*)(unsigned char *,unsigned char *,unsigned char *))
        rtc_get_time;

    /* init the pointer to the RTC function used for reading time */
    prtc_get_date=
        (void (*)(unsigned char *,unsigned char *,unsigned int *))
        rtc_get_date;

    /* follows the rest of the program */
    /* ... */
}
```

Notes:

- If the return type of the RTC functions is different from **void**, like required by the **prtc_get_time** and **prtc_get_date** pointer declarations, then casting to the appropriate type must be performed, like in the above example.

- If the system doesn't have a Real Time Clock, then these pointers must not be initialized at program startup. In this situation, they will be automatically initialized to NULL in the FAT access library and all files or directories created or modified by the FAT access functions will have the time stamp: January 1, 2009 00:00:00.

CodeVisionAVR

The FAT access functions are:

FRESULT f_mount(unsigned char vol, FATFS *fs)

allocates/deallocates a work area of memory for a logical drive volume. This function must be called first before any other FAT access function. In order to deallocate a work area associated with a logical drive, a NULL pointer must be passed as **fs**.

Note: This function only initializes the work area, no physical disk access is performed at this stage. The effective volume mount is performed on first file access after the function was called or after a media change.

Parameters:

vol specifies the logical drive number (0..9).
fs is a pointer to the FATFS type data structure associated with the logical drive that must be allocated/deallocated.

Return Values:

- FR_OK - success
- FR_INVALID_DRIVE - the drive number is invalid.

FRESULT f_open(FIL* fp, const char* path, unsigned char mode)

creates a file object **FIL** structure which will be used for accessing the file. The file read/write pointer is set to the start of the file.

Parameters:

fp points to the **FIL** type structure to be created. After the **f_open** function succeeds, this structure can be used by the other functions to access the file.
path points to a RAM based NULL terminated char string that represents the path name for the file to be created or opened.
The path name has the following format:

[logical_drive_number:][/][directory_name/]file_name

Examples:

file.txt - a file located in the current directory (specified previously by the **f_chdir** function) on the current drive (specified previously by the **f_chdrive** function).

/file.txt - a file located in the root directory of the current drive.

0:file.txt - a file located in the current directory (specified previously by the **f_chdir** function) on the logical drive 0.

0:/ - the root directory of logical drive 0.

0:/file.txt - a file located in the root directory of logical drive 0.

. - current directory.

.. - parent directory of the current directory.

The file_name must have the DOS 8.3 short file name format.

CodeVisionAVR

mode is the file access type and open method, represented by a combination of the flags specified by the following macros:

- **FA_READ** - Read access to the object. Data can be read from the file. For read-write access it must be combined with **FA_WRITE**.
- **FA_WRITE** - Write access to the object. Data can be written to the file. For read-write access it must be combined with **FA_READ**.
- **FA_OPEN_EXISTING** - Opens the file. If the file doesn't exist, the function will fail.
- **FA_OPEN_ALWAYS** - If the file exists, it will be opened. If the file doesn't exist, it will be first created and then opened.
- **FA_CREATE_NEW** - Creates a new file. If the file already exists, the function will fail.
- **FA_CREATE_ALWAYS** - Creates a new file. If the file already exists, it will be overwritten and its size set to 0.

Return values:

- **FR_OK** - success.
- **FR_NO_FILE** - couldn't find the file.
- **FR_NO_PATH** - couldn't find the path.
- **FR_INVALID_NAME** - the file name is invalid.
- **FR_INVALID_DRIVE** - the drive number is invalid.
- **FR_EXIST** - the file already exists.
- **FR_DENIED** - file access was denied because one of the following reasons:
 - trying to open a read-only file in write mode
 - file couldn't be created because a file with the same name or read-only attribute already exists
 - file couldn't be created because the directory table or disk are full.
- **FR_NOT_READY** - no disk access was possible due to missing media or other reason.
- **FR_WRITE_PROTECTED** - opening in write mode or creating a file was not possible because the media is write protected.
- **FR_DISK_ERR** - the function failed because of a physical disk access function failure.
- **FR_INT_ERR** - the function failed due to a wrong FAT structure or an internal error.
- **FR_NOT_ENABLED** - the logical drive was not mounted with **f_mount**.
- **FR_NO_FILESYSTEM** - there is no valid FAT partition on the disk.

FRESULT f_read(FIL* fp, void* buff, unsigned int btr, unsigned int* br)

reads data from a file previously opened with **f_open**.

After the function is executed, the file read/write pointer advances with the number of bytes read from the file.

Parameters:

fp points to the **FIL** type structure that contains the file parameters. This structure must have been previously initialized by calling the **f_open** function.

buff points to a byte buffer array, located in RAM, that will hold the data read from the file. The size of the buffer must be large enough so that the data will fit in.

btr specifies the number of bytes to be read from the file.

br points to an unsigned int variable that will hold the number of bytes of data effectively read from the file. On function success, if the number of effectively read bytes is smaller than the **btr** value, then the file read/write pointer reached the end of the file.

Return values:

- FR_OK - success.
- FR_DENIED - file access was denied because it was opened in write-only mode.
- FR_NOT_READY - no disk access was possible due to missing media or other reason.
- FR_DISK_ERR - the function failed because of a physical disk access function failure.
- FR_INT_ERR - the function failed due to a wrong FAT structure or an internal error.
- FR_INVALID_OBJECT - the file was not opened with **f_open**.

FRESULT f_write(FIL* fp, const void* buff, unsigned int btw, unsigned int* bw)

writes data to a file previously opened with **f_open**.

After the function is executed, the file read/write pointer advances with the number of bytes written to the file.

Parameters:

fp points to the **FIL** type structure that contains the file parameters. This structure must have been previously initialized by calling the **f_open** function.

buff points to a byte buffer array, located in RAM, that holds the data to be written to the file.

btw specifies the number of bytes to be written to the file.

bw points to an unsigned int variable that will hold the number of bytes of data effectively written to the file.

Return values:

- FR_OK - success.
- FR_DENIED - file access was denied because it was opened in read-only mode.
- FR_NOT_READY - no disk access was possible due to missing media or other reason.
- FR_DISK_ERR - the function failed because of a physical disk access function failure.
- FR_INT_ERR - the function failed due to a wrong FAT structure or an internal error.
- FR_INVALID_OBJECT - the file was not opened with **f_open**.

FRESULT f_lseek(FIL* fp, unsigned long ofs)

moves the file read/write pointer of a file previously opened with **f_open**.

In write-mode, this function can be also used to extend the file size, by moving the file read/write pointer past the end of the file. On success the value of the **fptr** member of the **FIL** structure, pointed by **fp**, must be checked to see if the file read/write pointer effectively advanced to the correct position and the drive didn't get full.

In read-mode, trying to advance the file read/write pointer past the end, will limit it's position to the end of the file. In this case the **fptr** member of the **FIL** structure, pointed by **fp**, will hold the size of the file.

Parameters:

fp points to the **FIL** type structure that contains the file parameters. This structure must have been previously initialized by calling the **f_open** function.

ofs represents the byte position where the file read/write pointer must be placed starting with the beginning of the file.

Return values:

- FR_OK - success.
- FR_NOT_READY - no disk access was possible due to missing media or other reason.
- FR_DISK_ERR - the function failed because of a physical disk access function failure.
- FR_INT_ERR - the function failed due to a wrong FAT structure or an internal error.
- FR_INVALID_OBJECT - the file was not opened with **f_open**.

FRESULT f_truncate(FIL* fp)

truncates the file's size to the current position of the file read/write pointer.
If the read/write pointer is already at the end of the file, the function will have no effect.

Parameter:

fp points to the **FIL** type structure that contains the file parameters. This structure must have been previously initialized by calling the **f_open** function.

Return values:

- FR_OK - success.
- FR_DENIED - file access was denied because it was opened in read-only mode.
- FR_NOT_READY - no disk access was possible due to missing media or other reason.
- FR_DISK_ERR - the function failed because of a physical disk access function failure.
- FR_INT_ERR - the function failed due to a wrong FAT structure or an internal error.
- FR_INVALID_OBJECT - the file was not opened with **f_open**.

FRESULT f_close(FIL* fp)

closes a file previously opened using **f_open**.
If any data was written to the file, the cached information is written to the disk.
After the function succeeded, the **FIL** type structure pointed by **fp**, is not valid anymore and the RAM memory allocated for it can be released.
If the file was opened in read-only mode, the memory allocated for the **FIL** type structure, pointed by **fp**, can be released without the need for previously calling the **f_close** function.

Parameter:

fp points to the **FIL** type structure that contains the file parameters. This structure must have been previously initialized by calling the **f_open** function.

Return values:

- FR_OK - success.
- FR_NOT_READY - no disk access was possible due to missing media or other reason.
- FR_DISK_ERR - the function failed because of a physical disk access function failure.
- FR_INT_ERR - the function failed due to a wrong FAT structure or an internal error.
- FR_INVALID_OBJECT - the file was not opened with **f_open**.

FRESULT f_sync(FIL* fp)

flushes the cached data when writing a file.
This function is useful for applications when a file is opened for a long time in write mode.
Calling **f_sync** periodically or right after **f_write** minimizes the risk of data loss due to power failure or media removal from the drive.

Note: There is no need to call **f_sync** before **f_close**, as the later also performs a write cache flush.

Parameter:

fp points to the **FIL** type structure that contains the file parameters. This structure must have been previously initialized by calling the **f_open** function.

Return values:

- FR_OK - success.
- FR_NOT_READY - no disk access was possible due to missing media or other reason.
- FR_DISK_ERR - the function failed because of a physical disk access function failure.
- FR_INT_ERR - the function failed due to a wrong FAT structure or an internal error.
- FR_INVALID_OBJECT - the file was not opened with **f_open**.

FRESULT f_opendir(DIR* dj, const char* path)

opens an existing directory and initializes the **DIR** type structure that holds directory information, which may be used by other FAT access functions.
The memory allocated for the **DIR** type structure may be de-allocated at any time.

Parameters:

dj points to the **DIR** type structure that must be initialized.
path points to a RAM based NULL terminated char string that represents the path name for the directory to be opened.

Return values:

- FR_OK - success.
- FR_NO_PATH - couldn't find the path.
- FR_INVALID_NAME - the directory name is invalid.
- FR_INVALID_DRIVE - the drive number is invalid.
- FR_NOT_READY - no disk access was possible due to missing media or other reason.
- FR_DISK_ERR - the function failed because of a physical disk access function failure.
- FR_INT_ERR - the function failed due to a wrong FAT structure or an internal error.
- FR_NOT_ENABLED - the logical drive was not mounted with **f_mount**.
- FR_NO_FILESYSTEM - there is no valid FAT partition on the disk.

CodeVisionAVR

FRESULT f_readdir(DIR* dj, FILINFO* fno)

sequentially reads directory entries.

In order to read all the items in a directory this function must be called repeatedly.

When all items were read, the function will return a empty NULL char string in the **fname** member of the **FILINFO** structure, without any error.

Note: The "." and ".." directory entries are not filtered and will appear in the read entries.

Parameters:

dj points to the **DIR** type structure that holds directory information previously initialized by calling the **f_opendir** function.

fno points to the **FILINFO** type structure that will hold the file information for a read directory entry. If a NULL pointer is passed as **fno**, the directory entry read process will start from the beginning.

Return values:

- FR_OK - success.
- FR_NOT_READY - no disk access was possible due to missing media or other reason.
- FR_DISK_ERR - the function failed because of a physical disk access function failure.
- FR_INT_ERR - the function failed due to a wrong FAT structure or an internal error.
- FR_NO_FILESYSTEM - there is no valid FAT partition on the disk.

Example:

```
/* ATmega128 I/O register definitions */
#include <mega128.h>
/* FAT on MMC/SD/SD HC card support */
#include <ff.h>
/* printf */
#include <stdio.h>
/* string functions */
#include <string.h>

/* Timer1 overflow interrupt frequency [Hz] */
#define T1_OVF_FREQ 100
/* Timer1 clock prescaler value */
#define T1_PRESC 1024L
/* Timer1 initialization value after overflow */
#define T1_INIT (0x10000L-(MCU_CLOCK_FREQUENCY_/ (T1_PRESC*T1_OVF_FREQ)))

/* USART Baud rate */
#define BAUD_RATE 19200
#define BAUD_INIT (MCU_CLOCK_FREQUENCY_/ (BAUD_RATE*16L)-1)

/* 100Hz timer interrupt generated by ATmega128 Timer1 overflow */
interrupt [TIM1_OVF] void timer_comp_isr(void)
{
    /* re-initialize Timer1 */
    TCNT1H=T1_INIT>>8;
    TCNT1L=T1_INIT&0xFF;
    /* MMC/SD/SD HC card access low level timing function */
    disk_timerproc();
}
```

CodeVisionAVR

```
/* error message list */
flash char * flash_error_msg[]=
{
    "", /* not used */
    "FR_DISK_ERR",
    "FR_INT_ERR",
    "FR_INT_ERR",
    "FR_NOT_READY",
    "FR_NO_FILE",
    "FR_NO_PATH",
    "FR_INVALID_NAME",
    "FR_DENIED",
    "FR_EXIST",
    "FR_INVALID_OBJECT",
    "FR_WRITE_PROTECTED",
    "FR_INVALID_DRIVE",
    "FR_NOT_ENABLED",
    "FR_NO_FILESYSTEM",
    "FR_MKFS_ABORTED",
    "FR_TIMEOUT"
};

/* display error message and stop */
void error(FRESULT res)
{
    if ((res>=FR_DISK_ERR) && (res<=FR_TIMEOUT))
        printf("ERROR: %p\r\n",error_msg[res]);
    /* stop here */
    while(1);
}

/* will hold file/directory information returned by f_readdir*/
FILINFO file_info;

/* recursively scan directory entries and display them */
FRESULT directory_scan(char *path)
{
    /* will hold the directory information */
    DIR directory;
    /* FAT function result */
    FRESULT res;
    int i;
```

CodeVisionAVR

```
if ((res=f_opendir(&directory,path))==FR_OK)
{
while (((res=f_readdir(&directory,&file_info))==FR_OK) &&
file_info.fname[0])
{
/* display file/directory name and associated information */
printf("%c%c%c%c%c %02u/%02u/%u %02u:%02u:%02u %9lu"
" %s/%s\r\n",
(file_info.fattrib & AM_DIR) ? 'D' : '-',
(file_info.fattrib & AM_RDO) ? 'R' : '-',
(file_info.fattrib & AM_HID) ? 'H' : '-',
(file_info.fattrib & AM_SYS) ? 'S' : '-',
(file_info.fattrib & AM_ARC) ? 'A' : '-',
file_info.fdate & 0x1F,(file_info.fdate >> 5) & 0xF,
(file_info.fdate >> 9)+1980,
file_info.ftime >> 11,(file_info.ftime >> 5) & 0x3F,
(file_info.ftime & 0xF) << 1,
file_info.fsize,path,file_info.fname);
if (file_info.fattrib & AM_DIR)
{
/* it's a subdirectory */
/* make sure to skip past "." and ".." when recursing */
if (file_info.fname[0]!='.')
{
i=strlen(path);
/* append the subdirectory name to the path */
if (path[i-1]!='/') strcatf(path,"/");
strcat(path,file_info.fname);
/* scan subdirectory */
res=directory_scan(path);
/* restore the old path name */
path[i]=0;
/* remove any eventual '/' from the end of the path */
--i;
if (path[i]=='/') path[i]=0;
/* stop if an error occurred */
if (res!=FR_OK) break;
}
}
}
}
return res;
}

void main(void)
{
/* FAT function result */
FRESULT res;
/* will hold the information for logical drive 0: */
FATFS drive;
/* root directory path */
char path[256]="0:/";
```

CodeVisionAVR

```
/* initialize Timer1 overflow interrupts in Mode 0 (Normal) */
TCCR1A=0x00;
/* clkio/1024 */
TCCR1B=(1<<CS12)|(1<<CS10);
/* timer overflow interrupts will occur with 100Hz frequency */
TCNT1H=T1_INIT>>8;
TCNT1L=T1_INIT&0xFF;
/* enable Timer1 overflow interrupt */
TIMSK=1<<TOIE1;

/* initialize the USART0 TX, 8N1, Baud rate: 19200 */
UCSR0A=0;
UCSR0B=1<<TXEN0;
UCSR0C=(1<<UCSZ01)|(1<<UCSZ00);
UBRR0H=BAUD_INIT>>8;
UBRR0L=BAUD_INIT&0xFF;

/* globally enable interrupts */
#asm("sei")

printf("Directory listing for root of logical drive 0:\r\n");

/* mount logical drive 0: */
if ((res=f_mount(0,&drive))==FR_OK)
    printf("Logical drive 0: mounted OK\r\n");
else
    /* an error occurred, display it and stop */
    error(res);

/* repeatedly read directory entries and display them */
if ((res=directory_scan(path))!=FR_OK)
    /* if an error occurred, display it and stop */
    error(res);

/* stop here */
while(1);
}
```

Note: When compiling the above example, make sure that the **(s)printf Features** option in the **Project|Configure|C Compiler|Code Generation** menu will be set to: **long, width**. This will ensure that the unsigned long int file sizes will be displayed correctly by the **printf** function.

FRESULT f_stat(const char* path, FILINFO* fno)

gets the file or directory status in a **FILINFO** type structure.

Parameters:

path points to a RAM based NULL terminated char string that represents the path name for the file or directory.

fno points to the **FILINFO** type structure that will hold the status information.

Return values:

- **FR_OK** - success.
- **FR_NO_FILE** - couldn't find the file.
- **FR_NO_PATH** - couldn't find the path.
- **FR_INVALID_NAME** - the file name is invalid.
- **FR_INVALID_DRIVE** - the drive number is invalid.
- **FR_NOT_READY** - no disk access was possible due to missing media or other reason.
- **FR_WRITE_PROTECTED** - opening in write mode or creating a file was not possible because the media is write protected.
- **FR_DISK_ERR** - the function failed because of a physical disk access function failure.
- **FR_INT_ERR** - the function failed due to a wrong FAT structure or an internal error.
- **FR_NOT_ENABLED** - the logical drive was not mounted with **f_mount**.
- **FR_NO_FILESYSTEM** - there is no valid FAT partition on the disk.

FRESULT f_getfree(const char* path, unsigned long* nclst, FATFS fatfs)**

gets the number of free clusters on the drive.

Parameters:

path points to a RAM based NULL terminated char string that represents the path name of the root directory of the logical drive.

nclst points to an unsigned long int variable that will hold the number of free clusters.

fatfs points to a pointer to the FATFS type structure associated with the logical drive.

Return values:

- **FR_OK** - success.
- **FR_INVALID_DRIVE** - the drive number is invalid.
- **FR_NOT_READY** - no disk access was possible due to missing media or other reason.
- **FR_WRITE_PROTECTED** - opening in write mode or creating a file was not possible because the media is write protected.
- **FR_DISK_ERR** - the function failed because of a physical disk access function failure.
- **FR_INT_ERR** - the function failed due to a wrong FAT structure or an internal error.
- **FR_NOT_ENABLED** - the logical drive was not mounted with **f_mount**.
- **FR_NO_FILESYSTEM** - there is no valid FAT partition on the disk.

CodeVisionAVR

The **csize** member of the FATFS structure represents the number of sectors/cluster, so the free size in bytes can be calculated using the example below:

```
/* ATmega128 I/O register definitions */
#include <mega128.h>
/* FAT on MMC/SD/SD HC card support */
#include <ff.h>
/* printf */
#include <stdio.h>

/* Timer1 overflow interrupt frequency [Hz] */
#define T1_OVF_FREQ 100
/* Timer1 clock prescaler value */
#define T1_PRESC 1024L
/* Timer1 initialization value after overflow */
#define T1_INIT (0x10000L-(MCU_CLOCK_FREQUENCY_/(T1_PRESC*T1_OVF_FREQ)))

/* USART Baud rate */
#define BAUD_RATE 19200
#define BAUD_INIT (MCU_CLOCK_FREQUENCY_/(BAUD_RATE*16L)-1)

/* 100Hz timer interrupt generated by ATmega128 Timer1 overflow */
interrupt [TIM1_OVF] void timer_comp_isr(void)
{
    /* re-initialize Timer1 */
    TCNT1H=T1_INIT>>8;
    TCNT1L=T1_INIT&0xFF;
    /* card access low level timing function */
    disk_timerproc();
}

/* error message list */
flash char * flash_error_msg[]=
{
    "", /* not used */
    "FR_DISK_ERR",
    "FR_INT_ERR",
    "FR_INT_ERR",
    "FR_NOT_READY",
    "FR_NO_FILE",
    "FR_NO_PATH",
    "FR_INVALID_NAME",
    "FR_DENIED",
    "FR_EXIST",
    "FR_INVALID_OBJECT",
    "FR_WRITE_PROTECTED",
    "FR_INVALID_DRIVE",
    "FR_NOT_ENABLED",
    "FR_NO_FILESYSTEM",
    "FR_MKFS_ABORTED",
    "FR_TIMEOUT"
};
```

CodeVisionAVR

```
/* display error message and stop */
void error(FRESULT res)
{
if ((res>=FR_DISK_ERR) && (res<=FR_TIMEOUT))
    printf("ERROR: %p\r\n",error_msg[res]);
/* stop here */
while(1);
}

void main(void)
{
/* FAT function result */
FRESULT res;
/* will hold the information for logical drive 0: */
FATFS fat;
/* pointer to the FATFS type structure */
FATFS *pfat;
/* number of free clusters on logical drive 0:*/
unsigned long free_clusters;
/* number of free kbytes on logical drive 0: */
unsigned long free_kbytes;
/* root directory path for logical drive 0: */
char root_path[]="0:/";

/* initialize Timer1 overflow interrupts in Mode 0 (Normal) */
TCCR1A=0x00;
/* clkio/1024 */
TCCR1B=(1<<CS12)|(1<<CS10);
/* timer overflow interrupts will occur with 100Hz frequency */
TCNT1H=T1_INIT>>8;
TCNT1L=T1_INIT&0xFF;
/* enable Timer1 overflow interrupt */
TIMSK=1<<TOIE1;

/* initialize the USART0 TX, 8N1, Baud rate: 19200 */
UCSR0A=0;
UCSR0B=1<<TXEN0;
UCSR0C=(1<<UCSZ01)|(1<<UCSZ00);
UBRR0H=BAUD_INIT>>8;
UBRR0L=BAUD_INIT&0xFF;

/* globally enable interrupts */
#asm("sei")

/* point to the FATFS structure that holds
information for the logical drive 0: */
pfat=&fat;

/* mount logical drive 0: */
if ((res=f_mount(0,pfat))==FR_OK)
    printf("Logical drive 0: mounted OK\r\n");
else
    /* an error occured, display it and stop */
    error(res);
```

CodeVisionAVR

```
/* get the number of free clusters */
if ((res=f_getfree(root_path,&free_clusters,&pfat))==FR_OK)
{
    /* calculate the number of free bytes */
    free_kbytes=free_clusters *
        /* cluster size in sectors */
        pfat->csize
        /* divide by 2 to obtain the sector size in kbytes
        512 (sector size in bytes)/1024 = 1/2 kbytes
        we need to do the division by 2 directly,
        in order to prevent unsigned long multiplication
        overflow for 8GB+ SD HC cards */
        /2;
    /* display the number of free kbytes */
    printf("Free space on logical drive 0: %lu kbytes\r\n",free_kbytes);
}
else
    /* an error occurred, display it and stop */
    error(res);

/* stop here */
while(1);
}
```

Note: When compiling the above example, make sure that the **(s)printf Features** option in the **Project|Configure|C Compiler|Code Generation** menu will be set to: **long, width**. This will ensure that the unsigned long int file sizes will be displayed correctly by the **printf** function.

FRESULT f_mkdir (const char* path)

creates a new directory.

Parameter:

path points to a RAM based NULL terminated char string that represents the path name for the directory to be created.

Return values:

- FR_OK - success.
- FR_NO_PATH - couldn't find the path.
- FR_INVALID_NAME - the directory name is invalid.
- FR_INVALID_DRIVE - the drive number is invalid.
- FR_EXIST - the directory already exists.
- FR_DENIED - the directory couldn't be created because the directory table or disk are full.
- FR_NOT_READY - no disk access was possible due to missing media or other reason.
- FR_WRITE_PROTECTED - creating the directory was not possible because the media is write protected.
- FR_DISK_ERR - the function failed because of a physical disk access function failure.
- FR_INT_ERR - the function failed due to a wrong FAT structure or an internal error.
- FR_NOT_ENABLED - the logical drive was not mounted with **f_mount**.
- FR_NO_FILESYSTEM - there is no valid FAT partition on the disk.

FRESULT f_unlink(const char* path)

deletes an existing file or directory.

Parameter:

path points to a RAM based NULL terminated char string that represents the path name for the file or directory to be deleted.

Return values:

- FR_OK - success.
- FR_NO_FILE - couldn't find the file or directory.
- FR_NO_PATH - couldn't find the path.
- FR_INVALID_NAME - the file or directory name is invalid.
- FR_INVALID_DRIVE - the drive number is invalid.
- FR_DENIED - access was denied because one of the following reasons:
 - file or directory read-only attribute is set
 - the directory is not empty.
- FR_NOT_READY - no disk access was possible due to missing media or other reason.
- FR_WRITE_PROTECTED - the media in the drive is write protected.
- FR_DISK_ERR - the function failed because of a physical disk access function failure.
- FR_INT_ERR - the function failed due to a wrong FAT structure or an internal error.
- FR_NOT_ENABLED - the logical drive was not mounted with **f_mount**.
- FR_NO_FILESYSTEM - there is no valid FAT partition on the disk.

FRESULT f_chmod (const char* path, unsigned char value, unsigned char mask)

changes the attribute of a file or directory.

Parameters:

path points to a RAM based NULL terminated char string that represents the path name for the file or directory.

value specifies the new combination of attribute flags to be set.

mask specifies the combination of which attribute flags must be changed.

The attribute is obtained by combining the following predefined macros:

- AM_RDO - Read Only attribute flag
- AM_HID - Hidden attribute flag
- AM_SYS - System attribute flag
- AM_ARC - Archive attribute flag

using the | binary OR operator.

Return values:

- FR_OK - success.
- FR_NO_FILE - couldn't find the file or directory.
- FR_NO_PATH - couldn't find the path.
- FR_INVALID_NAME - the file or directory name is invalid.
- FR_INVALID_DRIVE - the drive number is invalid.
- FR_NOT_READY - no disk access was possible due to missing media or other reason.
- FR_WRITE_PROTECTED - the media in the drive is write protected.
- FR_DISK_ERR - the function failed because of a physical disk access function failure.
- FR_INT_ERR - the function failed due to a wrong FAT structure or an internal error.
- FR_NOT_ENABLED - the logical drive was not mounted with **f_mount**.
- FR_NO_FILESYSTEM - there is no valid FAT partition on the disk.

FRESULT f_utime (const char* path, const FILINFO* fno)

changes the time stamp of a file or directory.

Parameters:

path points to a RAM based NULL terminated char string that represents the path name for the file or directory.

fno points to the **FILINFO** type structure that holds the file information and has the time stamp to be set contained in the **fdate** and **ftime** members.

Return values:

- FR_OK - success.
- FR_NO_FILE - couldn't find the file or directory.
- FR_NO_PATH - couldn't find the path.
- FR_INVALID_NAME - the file or directory name is invalid.
- FR_INVALID_DRIVE - the drive number is invalid.
- FR_NOT_READY - no disk access was possible due to missing media or other reason.
- FR_WRITE_PROTECTED - the media in the drive is write protected.
- FR_DISK_ERR - the function failed because of a physical disk access function failure.
- FR_INT_ERR - the function failed due to a wrong FAT structure or an internal error.
- FR_NOT_ENABLED - the logical drive was not mounted with **f_mount**.
- FR_NO_FILESYSTEM - there is no valid FAT partition on the disk.

CodeVisionAVR

Example:

```
/* ATmega128 I/O register definitions */
#include <mega128.h>
/* FAT on MMC/SD/SD HC card support */
#include <ff.h>
/* printf */
#include <stdio.h>
/* PCF8563 RTC functions*/
#include <PCF8563.h>

/* The PCF8563 RTC on the I2C bus is connected to ATmega128 PORTD
   SDA - PORTD.1
   SCL - PORTD.0
*/
#asm
    .equ __i2c_port=0x12
    .equ __sda_bit=1
    .equ __scl_bit=0
#endasm

/* Timer1 overflow interrupt frequency [Hz] */
#define T1_OVF_FREQ 100
/* Timer1 clock prescaler value */
#define T1_PRESC 1024L
/* Timer1 initialization value after overflow */
#define T1_INIT (0x10000L-( _MCU_CLOCK_FREQUENCY_/(T1_PRESC*T1_OVF_FREQ)))

/* USART Baud rate */
#define BAUD_RATE 19200
#define BAUD_INIT ( _MCU_CLOCK_FREQUENCY_/(BAUD_RATE*16L)-1)

/* FAT function result */
FRESULT res;
/* number of bytes written/read to the file */
unsigned int nbytes;
/* will hold the information for logical drive 0: */
FATFS fat;
/* will hold the file information */
FIL file;
/* will hold file attributes, time stamp information */
FILINFO finfo;
/* file path */
char path[]="0:/file.txt";
/* text to be written to the file */
char text[]="I like CodeVisionAVR!";
/* file read buffer */
char buffer[256];

/* 100Hz timer interrupt generated by ATmega128 Timer1 overflow */
interrupt [TIM1_OVF] void timer_comp_isr(void)
{
    /* re-initialize Timer1 */
    TCNT1H=T1_INIT>>8;
    TCNT1L=T1_INIT&0xFF;
    /* card access low level timing function */
    disk_timerproc();
}
```

CodeVisionAVR

```
/* error message list */
flash char * flash_error_msg[]=
{
    "", /* not used */
    "FR_DISK_ERR",
    "FR_INT_ERR",
    "FR_INT_ERR",
    "FR_NOT_READY",
    "FR_NO_FILE",
    "FR_NO_PATH",
    "FR_INVALID_NAME",
    "FR_DENIED",
    "FR_EXIST",
    "FR_INVALID_OBJECT",
    "FR_WRITE_PROTECTED",
    "FR_INVALID_DRIVE",
    "FR_NOT_ENABLED",
    "FR_NO_FILESYSTEM",
    "FR_MKFS_ABORTED",
    "FR_TIMEOUT"
};

/* display error message and stop */
void error(FRESULT res)
{
    if ((res>=FR_DISK_ERR) && (res<=FR_TIMEOUT))
        printf("ERROR: %p\r\n",error_msg[res]);
    /* stop here */
    while(1);
}

/* display file's attribute, size and time stamp */
void display_status(char *file_name)
{
    if ((res=f_stat(file_name,&finfo))==FR_OK)
        printf("File: %s, Attributes: %c%c%c%c\r\n"
            "Date: %02u/%02u/%u, Time: %02u:%02u:%02u\r\n"
            "Size: %lu bytes\r\n",
            finfo.fname,
            (finfo.fattrib & AM_DIR) ? 'D' : '-',
            (finfo.fattrib & AM_RDO) ? 'R' : '-',
            (finfo.fattrib & AM_HID) ? 'H' : '-',
            (finfo.fattrib & AM_SYS) ? 'S' : '-',
            (finfo.fattrib & AM_ARC) ? 'A' : '-',
            finfo.fdate & 0x1F, (finfo.fdate >> 5) & 0xF,
            (finfo.fdate >> 9) + 1980,
            (finfo.ftime >> 11), (finfo.ftime >> 5) & 0x3F,
            (finfo.ftime & 0xF) << 1,
            finfo.fsize);
    else
        /* an error occured, display it and stop */
        error(res);
}
```

CodeVisionAVR

```
void main(void)
{
/* initialize Timer1 overflow interrupts in Mode 0 (Normal) */
TCCR1A=0x00;
/* clkio/1024 */
TCCR1B=(1<<CS12)|(1<<CS10);
/* timer overflow interrupts will occur with 100Hz frequency */
TCNT1H=T1_INIT>>8;
TCNT1L=T1_INIT&0xFF;
/* enable Timer1 overflow interrupt */
TIMSK=1<<TOIE1;

/* initialize the USART0 TX, 8N1, Baud rate: 19200 */
UCSR0A=0;
UCSR0B=1<<TXEN0;
UCSR0C=(1<<UCSZ01)|(1<<UCSZ00);
UBRR0H=BAUD_INIT>>8;
UBRR0L=BAUD_INIT&0xFF;

/* init the PCF8563 RTC */
rtc_init(0,RTC_CLKOUT_OFF,RTC_TIMER_OFF);

/* init the pointer to the RTC function used for reading time */
prtc_get_time=
    (void (*)(unsigned char *,unsigned char *,unsigned char *))
    rtc_get_time;

/* init the pointer to the RTC function used for reading time */
prtc_get_date=
    (void (*)(unsigned char *,unsigned char *,unsigned int *))
    rtc_get_date;

/* globally enable interrupts */
#asm("sei")

/* mount logical drive 0: */
if ((res=f_mount(0,&fat))==FR_OK)
    printf("Logical drive 0: mounted OK\r\n");
else
    /* an error occurred, display it and stop */
    error(res);

printf("%s \r\n",path);

/* create a new file in the root of drive 0:
and set write access mode */
if ((res=f_open(&file,path,FA_CREATE_ALWAYS | FA_WRITE))==FR_OK)
    printf("File %s created OK\r\n",path);
else
    /* an error occurred, display it and stop */
    error(res);

/* write some text to the file,
without the NULL string terminator sizeof(data)-1 */
if ((res=f_write(&file,text,sizeof(text)-1,&nbytes))==FR_OK)
    printf("%u bytes written of %u\r\n",nbytes,sizeof(text)-1);
else
    /* an error occurred, display it and stop */
    error(res);
```

CodeVisionAVR

```
/* close the file */
if ((res=f_close(&file))==FR_OK)
    printf("File %s closed OK\r\n",path);
else
    /* an error ocured, display it and stop */
    error(res);

/* open the file in read mode */
if ((res=f_open(&file,path,FA_READ))==FR_OK)
    printf("File %s opened OK\r\n",path);
else
    /* an error ocured, display it and stop */
    error(res);

/* read and display the file's content.
make sure to leave space for a NULL terminator
in the buffer, so maximum sizeof(buffer)-1 bytes can be read */
if ((res=f_read(&file,buffer,sizeof(buffer)-1,&nbytes))==FR_OK)
{
    printf("%u bytes read\r\n",nbytes);
    /* NULL terminate the char string in the buffer */
    buffer[nbytes+1]=NULL;
    /* display the buffer contents */
    printf("Read text: \"%s\"\r\n",buffer);
}
else
    /* an error ocured, display it and stop */
    error(res);

/* close the file */
if ((res=f_close(&file))==FR_OK)
    printf("File %s closed OK\r\n",path);
else
    /* an error ocured, display it and stop */
    error(res);

/* display file's attribute, size and time stamp */
display_status(path);

/* change file's attributes, set the file to be Read-Only */
if ((res=f_chmod(path,AM_RDO,AM_RDO))==FR_OK)
    printf("Read-Only attribute set OK\r\n",path);
else
    /* an error ocured, display it and stop */
    error(res);
```

CodeVisionAVR

```
/* change file's time stamp */
#define DAY (6)
#define MONTH (3)
#define YEAR (2000)
#define SECOND (0)
#define MINUTE (40)
#define HOUR (14)

finfo.fdate=DAY | (MONTH<<5) | ((YEAR-1980)<<9);
finfo.ftime=(SECOND>>1) | (MINUTE<<5) | (HOUR<<11);
if ((res=f_utime(path,&finfo))==FR_OK)
    printf("New time stamp %02u/%02u/%u %02u:%02u:%02u set OK\r\n",
        DAY,MONTH,YEAR,HOUR,MINUTE,SECOND);
else
    /* an error ocured, display it and stop */
    error(res);

/* display file's new attribute and time stamp */
display_status(path);

/* change file's attributes, clear the Read-Only attribute */
if ((res=f_chmod(path,0,AM_RDO))==FR_OK)
    printf("Read-Only attribute cleared OK\r\n",path);
else
    /* an error ocured, display it and stop */
    error(res);

/* display file's new attribute and time stamp */
display_status(path);

/* stop here */
while(1);
}
```

Note: When compiling the above example, make sure that the **(s)printf Features** option in the **Project|Configure|C Compiler|Code Generation** menu will be set to: **int, width**.

CodeVisionAVR

FRESULT f_rename(const char* path_old, const char* path_new)

renames a file or directory.

If the new path contains a different directory than the old path, the file will be also moved to this directory.

The logical drive is determined by the old path, it must not be specified in the new path.

Parameters:

path_old points to a RAM based NULL terminated char string that represents the path name for the file or directory to be renamed.

path_new points to a RAM based NULL terminated char string that represents the new path name for the file or directory.

Return values:

- FR_OK - success.
- FR_NO_FILE - couldn't find the file or directory.
- FR_NO_PATH - couldn't find the path.
- FR_INVALID_NAME - the file or directory name is invalid.
- FR_INVALID_DRIVE - the drive number is invalid.
- FR_NOT_READY - no disk access was possible due to missing media or other reason.
- FR_EXIST - the file or directory already exists.
- FR_DENIED - the file or directory couldn't be created or moved from any reason..
- FR_WRITE_PROTECTED - the media in the drive is write protected.
- FR_DISK_ERR - the function failed because of a physical disk access function failure.
- FR_INT_ERR - the function failed due to a wrong FAT structure or an internal error.
- FR_NOT_ENABLED - the logical drive was not mounted with **f_mount**.
- FR_NO_FILESYSTEM - there is no valid FAT partition on the disk.

FRESULT f_chdir(const char* path)

changes the current directory of the current logical drive.

When the drive is mounted, the current directory is the root directory.

Note: After **f_chdir** is called, all subsequent file access function operations will be performed by default in the new current directory, if no other directory is specified when calling these functions.

Parameter:

path points to a RAM based NULL terminated char string that represents the path name for the directory to go.

Return values:

- FR_OK - success.
- FR_NO_PATH - couldn't find the path.
- FR_INVALID_NAME - the file or directory name is invalid.
- FR_INVALID_DRIVE - the drive number is invalid.
- FR_NOT_READY - no disk access was possible due to missing media or other reason.
- FR_DISK_ERR - the function failed because of a physical disk access function failure.
- FR_INT_ERR - the function failed due to a wrong FAT structure or an internal error.
- FR_NOT_ENABLED - the logical drive was not mounted with **f_mount**.
- FR_NO_FILESYSTEM - there is no valid FAT partition on the disk.

FRESULT f_chdrive(unsigned char drv)

changes the current logical drive. The initial logical drive is 0.

Note: After **f_chdrive** is called, all subsequent file/directory access function operations will be performed by default on the new logical drive, if no other drive is specified when calling these functions.

Parameter:

drv specifies the logical drive number (0...9) to be set as current drive.

Return values:

- FR_OK - success.
- FR_INVALID_DRIVE - the drive number is invalid.

CodeVisionAVR

5. CodeWizardAVR Automatic Program Generator

The CodeWizardAVR Automatic Program Generator allows you to easily write all the code needed for implementing the following functions:

- External memory access setup
- Chip reset source identification
- Input/Output Port initialization
- External Interrupts initialization
- Timers/Counters initialization
- Watchdog Timer initialization
- UART initialization and interrupt driven buffered serial communication
- Analog Comparator initialization
- ADC initialization
- SPI Interface initialization
- I²C Bus, LM75 Temperature Sensor, DS1621 Thermometer/Thermostat, PCF8563, PCF8583, DS1302 and DS1307 Real Time Clocks initialization
- 1 Wire Bus and DS18B20/DS18S20 Temperature Sensors initialization
- LCD module initialization.

The Automatic Program Generator is invoked using the **Tools|CodeWizardAVR** menu command or by clicking on the  toolbar button.

The **File|New** menu command or the  toolbar button allow creating a new CodeWizardAVR project. This project will be named by default **untitled.cwp**.

The **File|Open** menu command or the  toolbar button allow loading an existing CodeWizardAVR project:

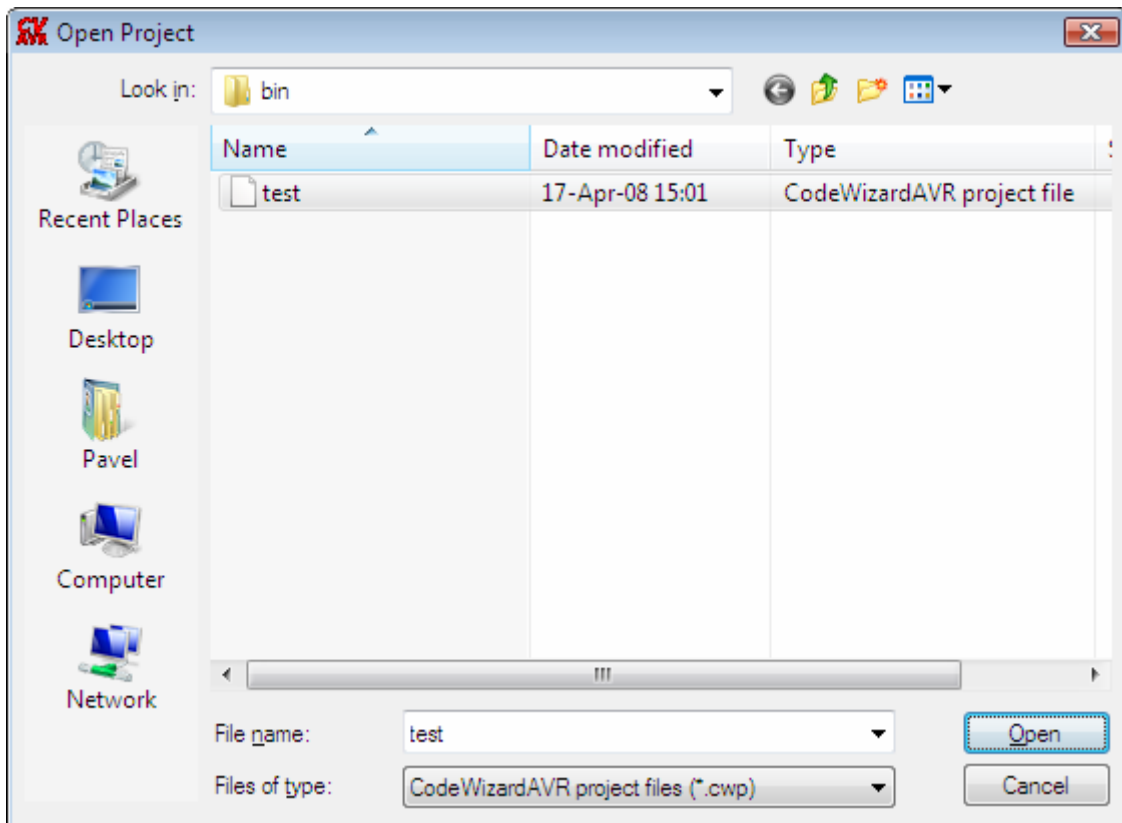



CodeVisionAVR

The **File|Save** menu command or the  toolbar button allow saving the currently opened CodeWizardAVR project.

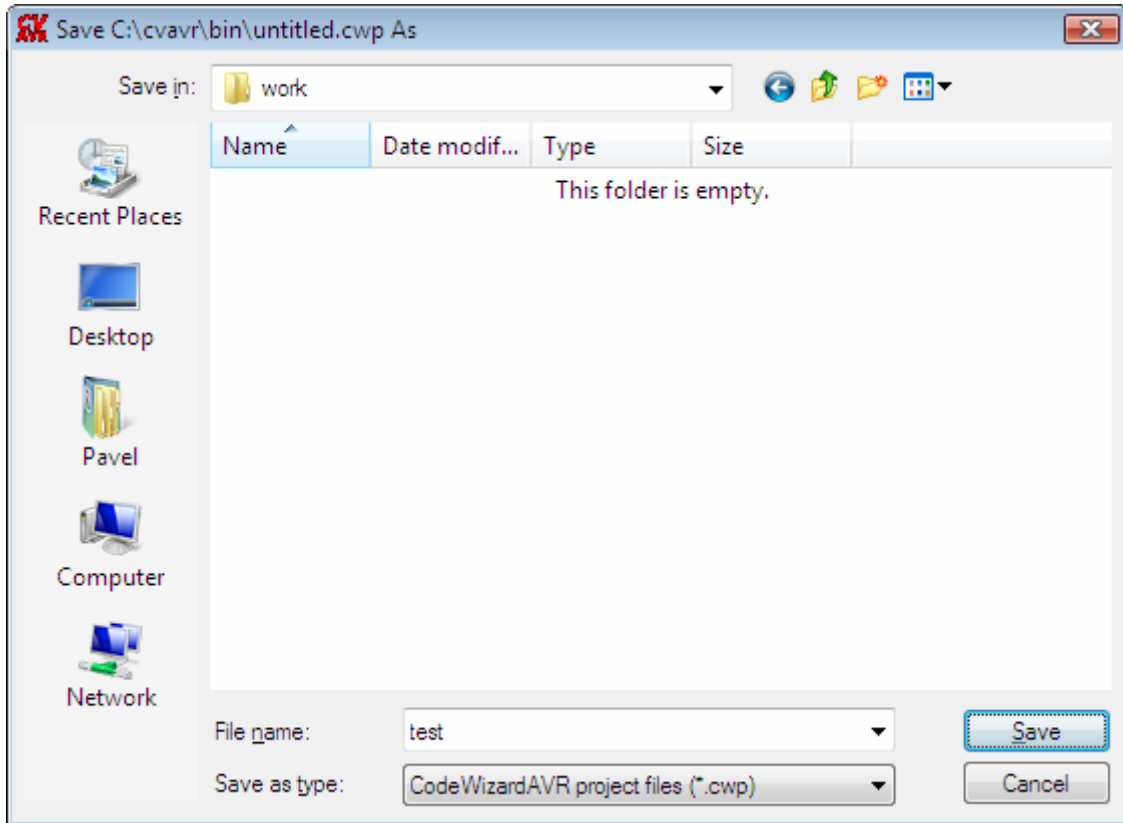
The **File|Save As** menu command or the  toolbar button allow saving the currently opened CodeWizardAVR project under a new name:



By selecting the **File|Program Preview** menu option or by clicking on the  toolbar button, the code generated by CodeWizardAVR can be viewed in the **Program Preview** window. This may be useful when applying changes to an existing project, as portions of code generated by the CodeWizardAVR can be selected, copied to the clipboard and then pasted in the project's source files.

If the **File|Generate, Save and Exit** menu option is selected or the  toolbar button is clicked, CodeWizardAVR will generate the main .C source and project .PRJ files, save the CodeWizardAVR project .CWP file and return to the CodeVisionAVR IDE. Eventual pin function conflicts will be prompted to the user, allowing him to correct the errors.

CodeVisionAVR

In the course of program generation the user will be prompted for the name of the main C file:

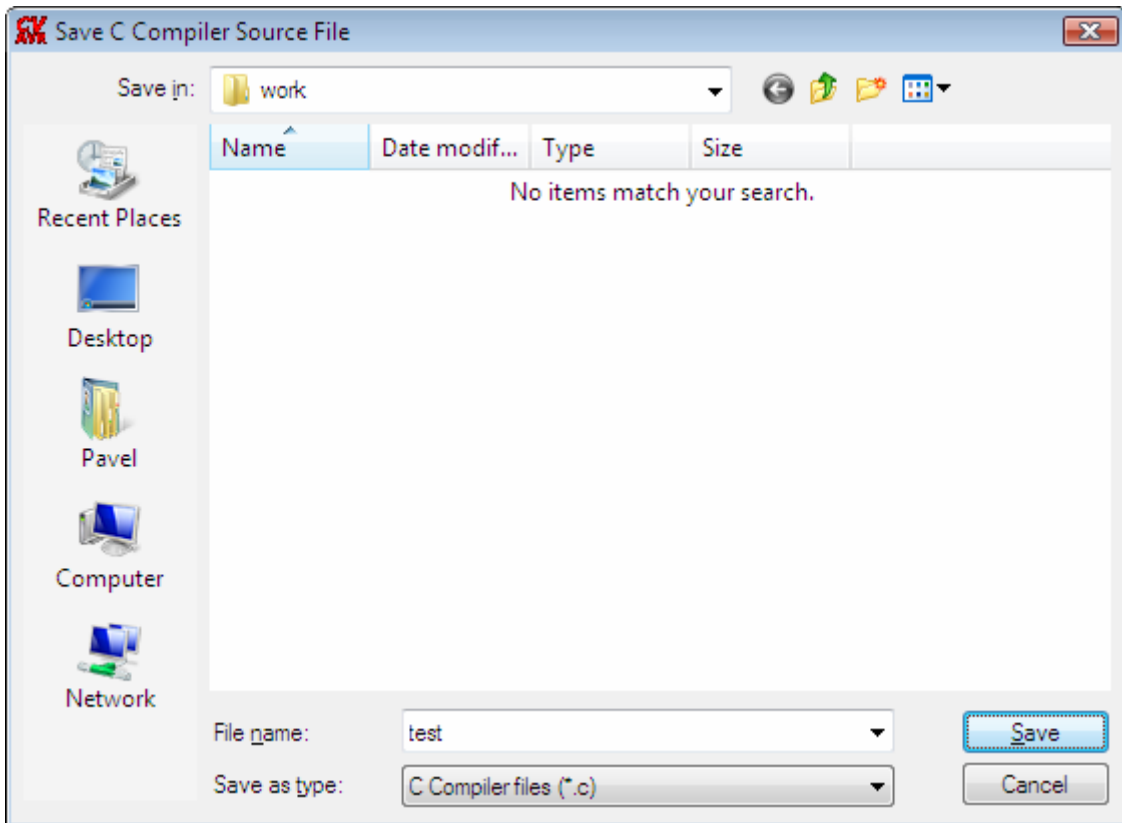

and for the name of the project file:

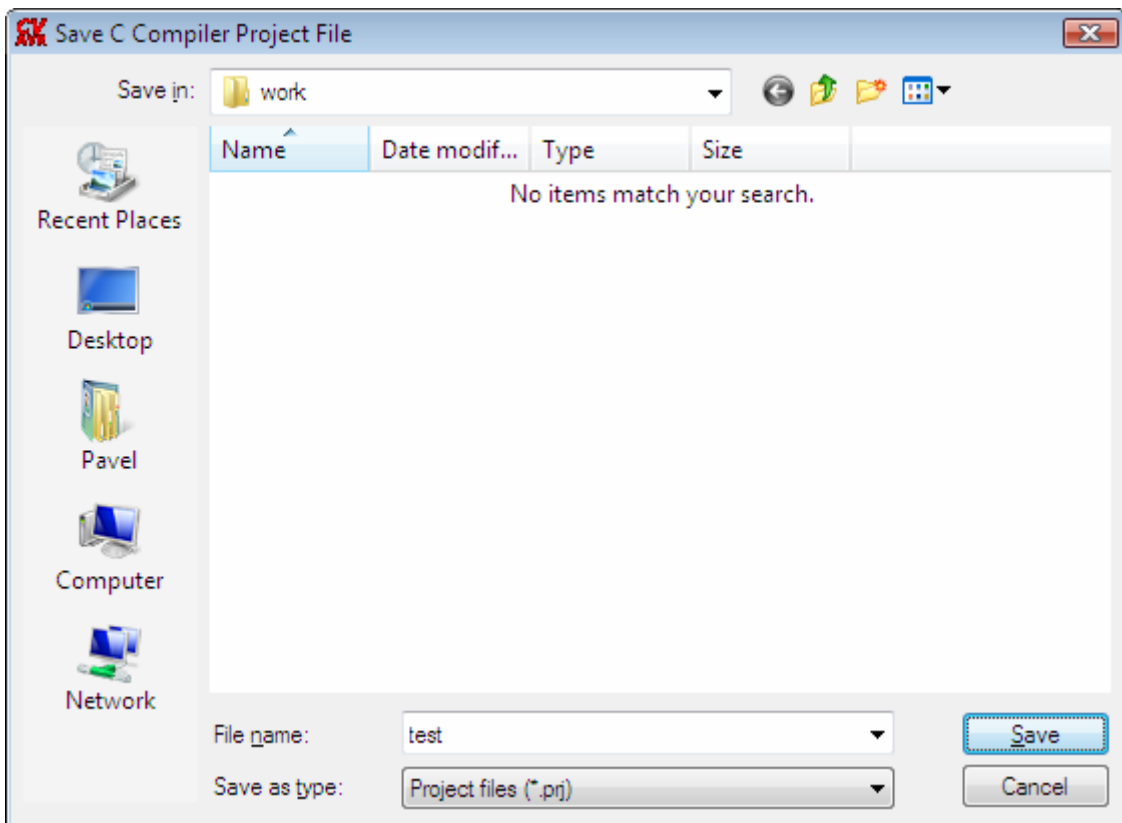

CodeVisionAVR

Selecting the **File|Exit** menu option allows the user to exit the CodeWizardAVR without generating any program files.

By selecting the **Help** menu option or by clicking on the  toolbar button, the user can see the help topic that corresponds to the current CodeWizardAVR configuration menu.

5.1 Setting the AVR Chip Options

By selecting the **Chip** tab of the CodeWizardAVR, you can set the AVR chip options.

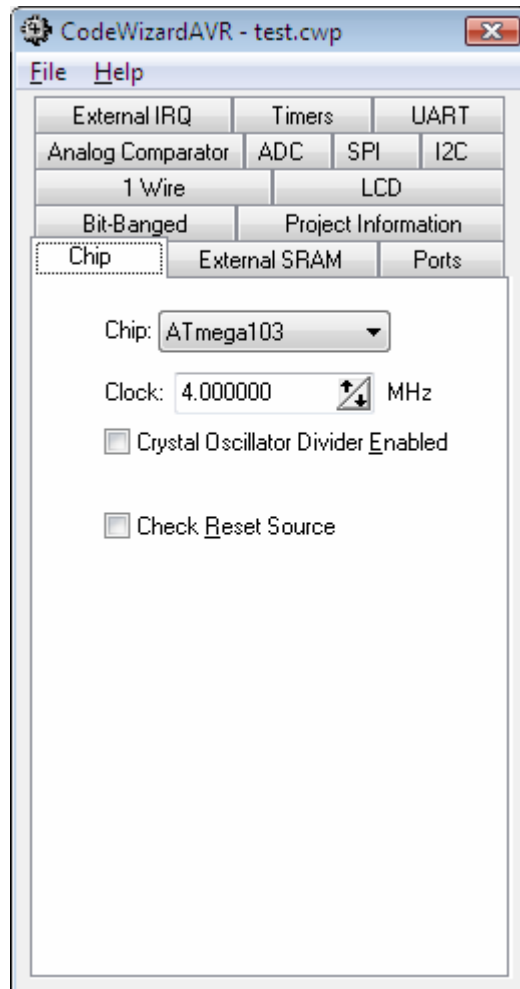

The chip type can be specified using the **Chip** list box.

The chip clock frequency in MHz can be specified using the **Clock** spinedit box.

For the AVR chips that contain a crystal oscillator divider, a supplementary **Crystal Oscillator Divider Enabled** check box is visible.

This check box allows you to enable or disable the crystal oscillator divider.

If the crystal oscillator is enabled, you can specify the division ratio using the **Crystal Oscillator Divider** spinedit box.

For the AVR chips that allow the identification of the reset source, a supplementary **Check Reset Source** check box is visible. If it's checked then the CodeWizardAVR will generate code that allows identification of the conditions that caused the chip reset.

CodeVisionAVR

For the AVR chips that allow self-programming, a supplementary **Program Type** list box is visible. It allows to select the type of the generated code:

- **Application**
- **Boot Loader**

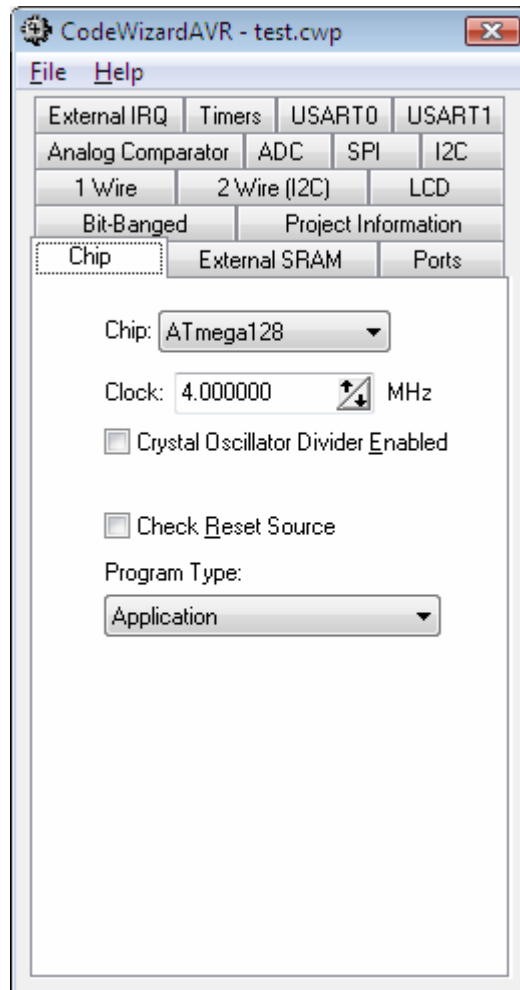

5.2 Setting the External SRAM

For the AVR chips that allow connection of external SRAM, you can specify the size of this memory and wait state insertion by selecting the **External SRAM** tab.

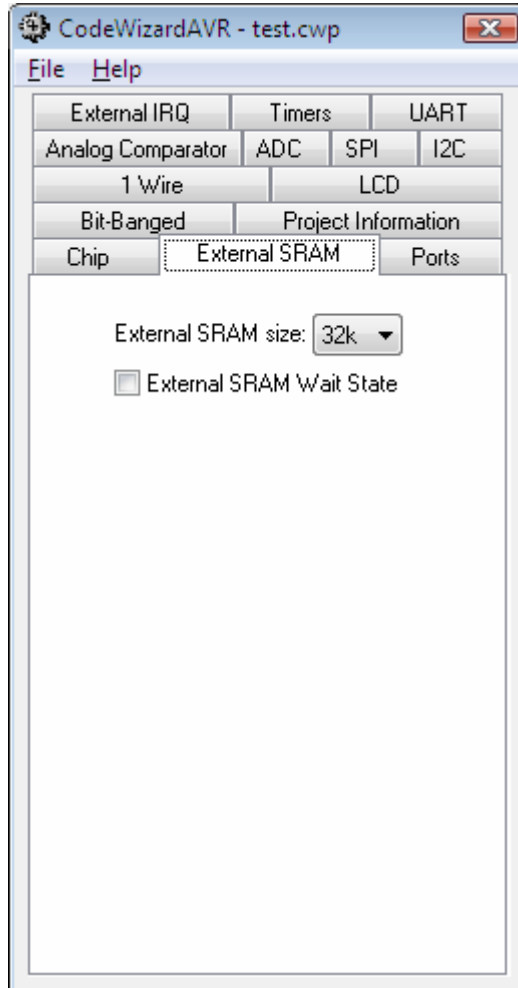

The size of external SRAM can be specified using the **External SRAM Size** list box. Additional wait states in accessing the external SRAM can be inserted by checking the **External SRAM Wait State** check box. The MCUCR register in the startup initialization code is configured automatically according to these settings.

CodeVisionAVR

For devices, like the ATmega128, that allow splitting the external SRAM in two pages, the External SRAM configuration window will look like this:

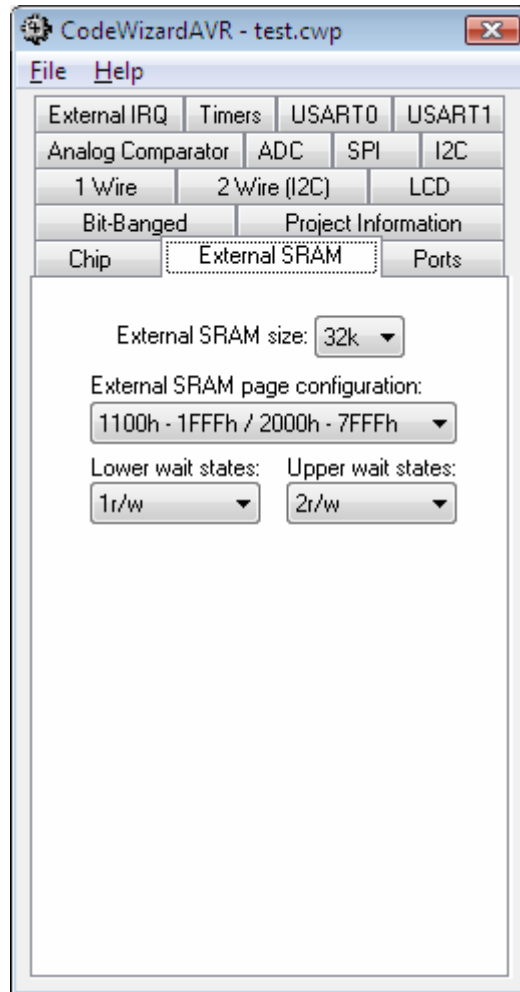

The **External SRAM page configuration** list box allows selection of the splitting address for the two external SRAM pages .

The wait states that are inserted during external SRAM access, can be specified for the lower, respectively upper, memory pages using the **Lower wait states**, respectively **Upper wait states** list boxes.

The MCUCR, EMCUCR, XMCRA registers in the startup initialization code are configured automatically according to these settings.

CodeVisionAVR

5.3 Setting the Input/Output Ports

By selecting the **Ports** tab of the CodeWizardAVR, you can specify the input/output Ports configuration.

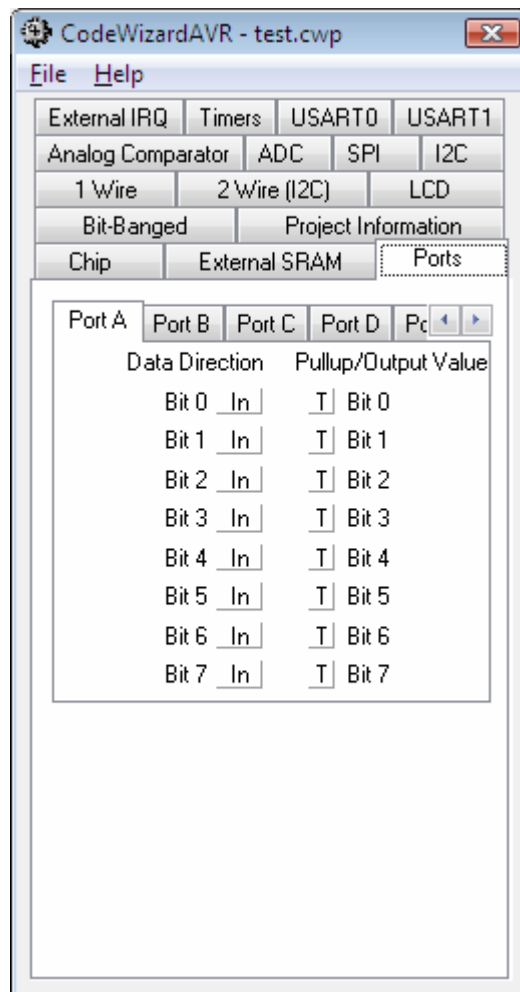

You can choose which port you want to configure by selecting the appropriate **PORT x** tab.

By clicking on the corresponding **Data Direction** bit you can set the chip pin to be output (Out) or input (In).

The DDRx register will be initialized according to these settings.

By clicking on the corresponding **Pullup/Output Value** bit you can set the following options:

- if the pin is an input, it can be tri-stated (T) or have an internal pull-up (P) resistor connected to the positive power supply.
- if the pin is an output, its value can be initially set to 0 or 1.

The PORTx register will be initialized according to these settings.

5.4 Setting the External Interrupts

By selecting the **External IRQ** tab of the CodeWizardAVR, you can specify the external interrupt configuration.

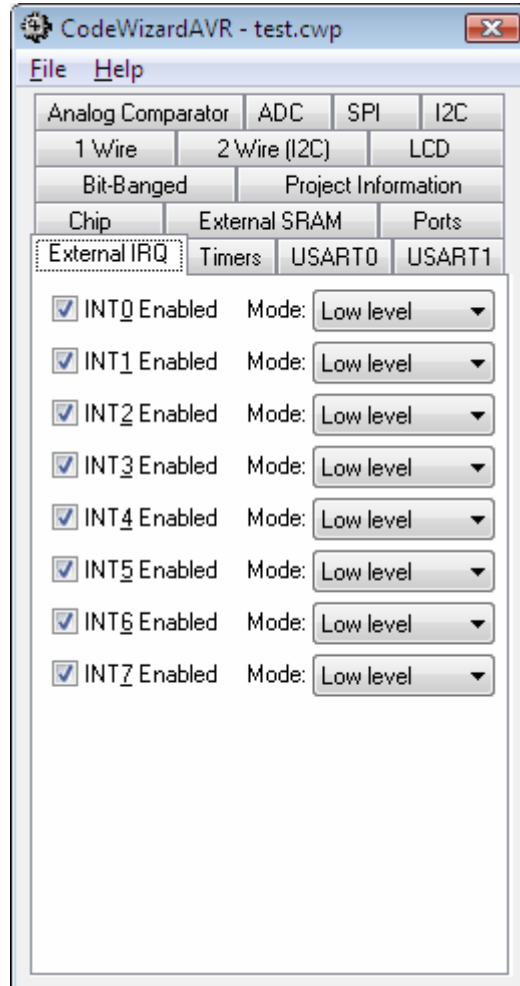

Checking the appropriate **INTx Enabled** check box enables the corresponding external interrupt. If the AVR chip supports this feature, you can select if the interrupt will be edge or level triggered using the corresponding **Mode** list box.

For each enabled external interrupt the CodeWizardAVR will define an **ext_intx_isr** interrupt service routine, where **x** is the number of the external interrupt.

CodeVisionAVR

For some devices, like the ATmega3290, the External IRQ tab may present the following options:

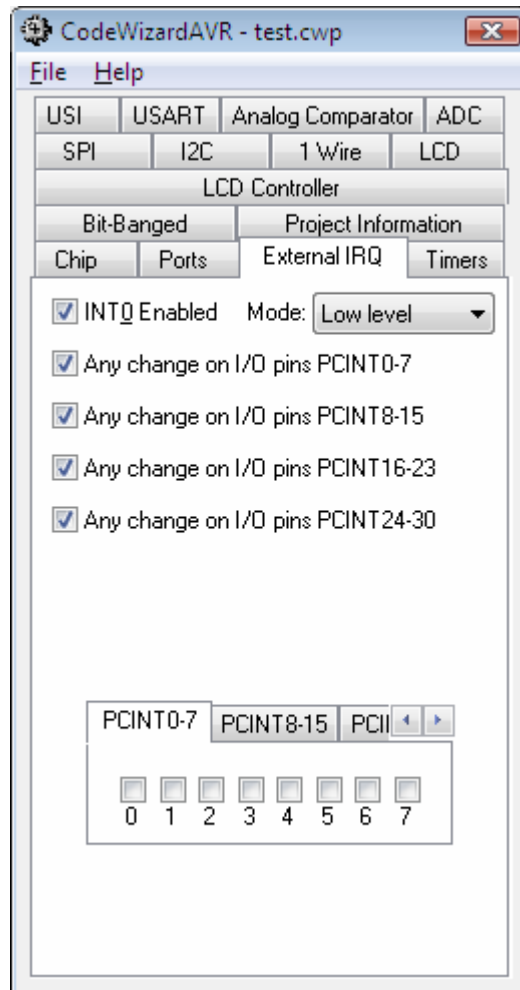

The **Any change on I/O pins** check boxes, if checked, will specify which of the PCINT I/O pins will trigger an external interrupt.

The interrupt service routines for these interrupts will be **pin_change_isr0** for PCINT0-7, **pin_change_isr1** for PCINT8-15, **pin_change_isr2** for PCINT16-23 and **pin_change_isr3** for PCINT24-30.

5.5 Setting the Timers/Counters

By selecting the **Timers** tab of the CodeWizardAVR, you can specify the timers/counters configuration.

A number of **Timer** tabs will be displayed according to the AVR chip type.

By selecting the **Timer 0** tab you can have the following options:

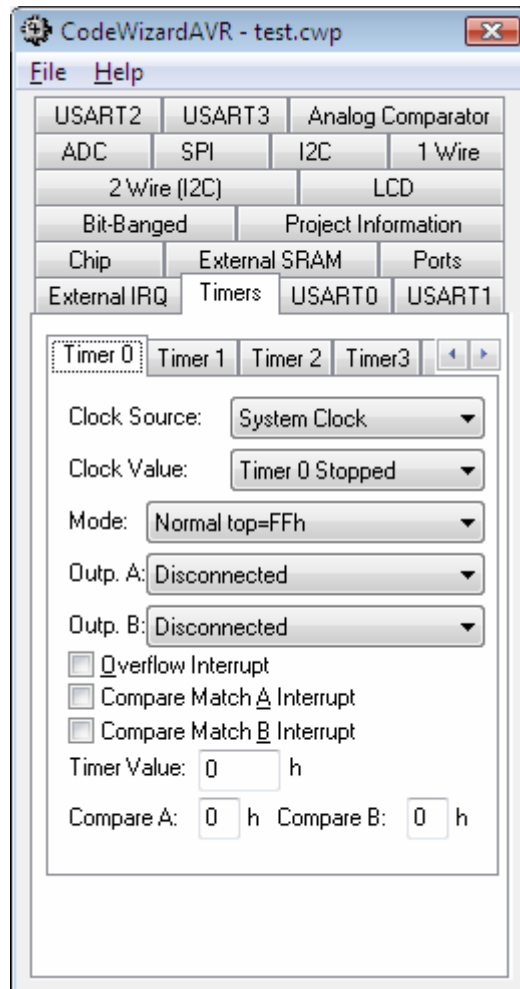

- **Clock Source** specifies the timer/counter 0 clock pulse source
- **Clock Value** specifies the timer/counter 0 clock frequency
- **Mode** specifies if the timer/counter 0 functioning mode
- **Outp. A** specifies the function of the timer/counter 0 compare A output and depends of the functioning mode
- **Outp. B** specifies the function of the timer/counter 0 compare B output and depends of the functioning mode
- **Overflow Interrupt** specifies if an interrupt is to be generated on timer/counter 0 overflow

CodeVisionAVR

- **Compare Match A Interrupt** specifies if an interrupt is to be generated on timer/counter 0 compare A match
- **Compare Match B Interrupt** specifies if an interrupt is to be generated on timer/counter 0 compare B match
- **Timer Value** specifies the initial value of timer/counter 0 at startup
- **Compare A** specifies the initial value of timer/counter 0 output compare A register
- **Compare B** specifies the initial value of timer/counter 0 output compare B register.

If timer/counter 0 interrupts are used the following interrupt service routines may be defined by the CodeWizardAVR:

- **timer0_ovf_isr** for timer/counter overflow
- **timer0_compa_isr** for timer/counter output compare A match
- **timer0_compb_isr** for timer/counter output compare B match

You must note that depending of the used AVR chip some of these options may not be present. For more information you must consult the corresponding Atmel data sheet.

CodeVisionAVR

By selecting the **Timer 1** tab you can have the following options:

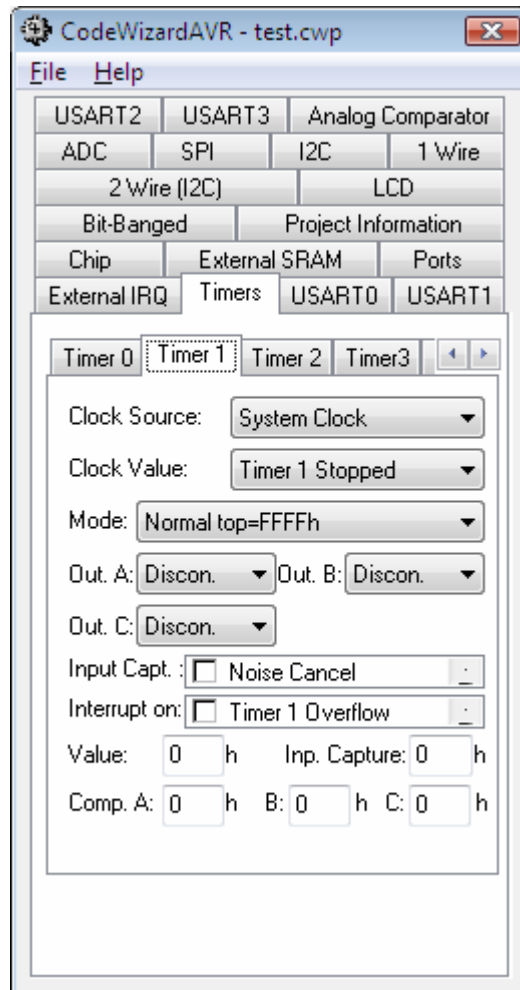

- **Clock Source** specifies the timer/counter 1 clock pulse source
- **Clock Value** specifies the timer/counter 1 clock frequency
- **Mode** specifies if the timer/counter 1 functioning mode
- **Out. A** specifies the function of the timer/counter 1 output A and depends of the functioning mode
- **Out. B** specifies the function of the timer/counter 1 output B and depends of the functioning mode
- **Out. C** specifies the function of the timer/counter 3 output C and depends of the functioning mode
- **Inp Capt.** specifies the timer/counter 1 capture trigger edge and if the noise canceler is to be used
- **Interrupt on** specifies if an interrupt is to be generated on timer/counter 1 overflow, input capture and compare match
- **Timer Value** specifies the initial value of timer/counter 1 at startup
- **Comp. A, B and C** specifies the initial value of timer/counter 1 output compare registers A, B and C.

If timer/counter 1 interrupts are used the following interrupt service routines may be defined by the CodeWizardAVR:

- **timer1_ovf_isr** for timer/counter overflow
- **timer1_comp_isr** or **timer1_compa_isr**, **timer1_compb_isr** and **timer1_copmc_isr** for timer/counter output compare match
- **timer1_capt_isr** for timer/counter input capture

You must note that depending of the used AVR chip some of these options may not be present. For more information you must consult the corresponding Atmel data sheet.

CodeVisionAVR

By selecting the **Timer 2** tab you can have the following options:

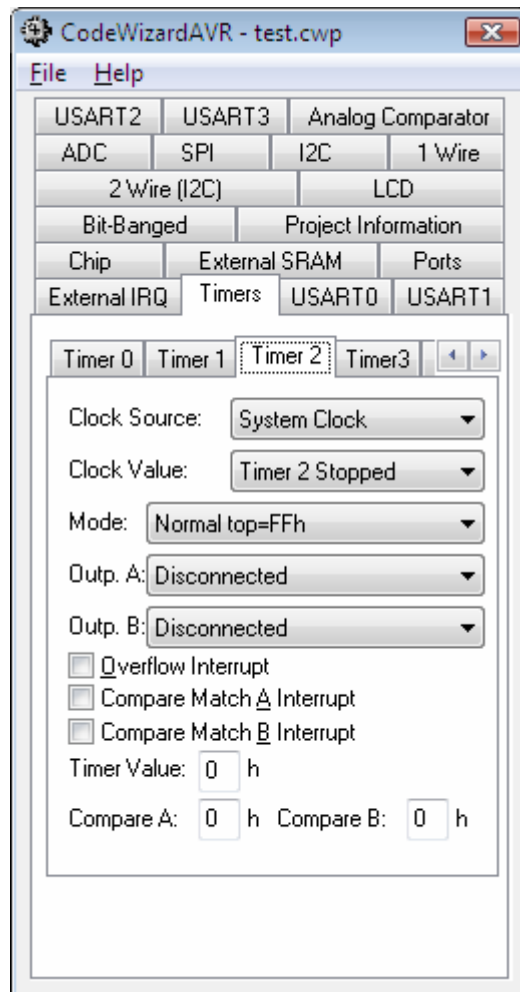

- **Clock Source** specifies the timer/counter 2 clock pulse source
- **Clock Value** specifies the timer/counter 2 clock frequency
- **Mode** specifies if the timer/counter 2 functioning mode
- **Out. A** specifies the function of the timer/counter 2 output A and depends of the functioning mode
- **Out. B** specifies the function of the timer/counter 2 output B and depends of the functioning mode
- **Overflow Interrupt** specifies if an interrupt is to be generated on timer/counter 2 overflow
- **Compare Match A Interrupt** specifies if an interrupt is to be generated on timer/counter 2 compare register A match
- **Compare Match B Interrupt** specifies if an interrupt is to be generated on timer/counter 2 compare register B match
- **Timer Value** specifies the initial value of timer/counter 2 at startup
- **Compare A** specifies the initial value of timer/counter 2 output compare A register
- **Compare B** specifies the initial value of timer/counter 2 output compare B register

If timer/counter 2 interrupts are used the following interrupt service routines may be defined by the CodeWizardAVR:

- **timer2_ovf_isr** for timer/counter overflow
- **timer2_comp_isr** and **timer2_compb_isr** for timer/counter output compare match.

You must note that depending of the used AVR chip some of these options may not be present. For more information you must consult the corresponding Atmel data sheet.

CodeVisionAVR

By selecting the **Timer 3** tab you can have the following options:

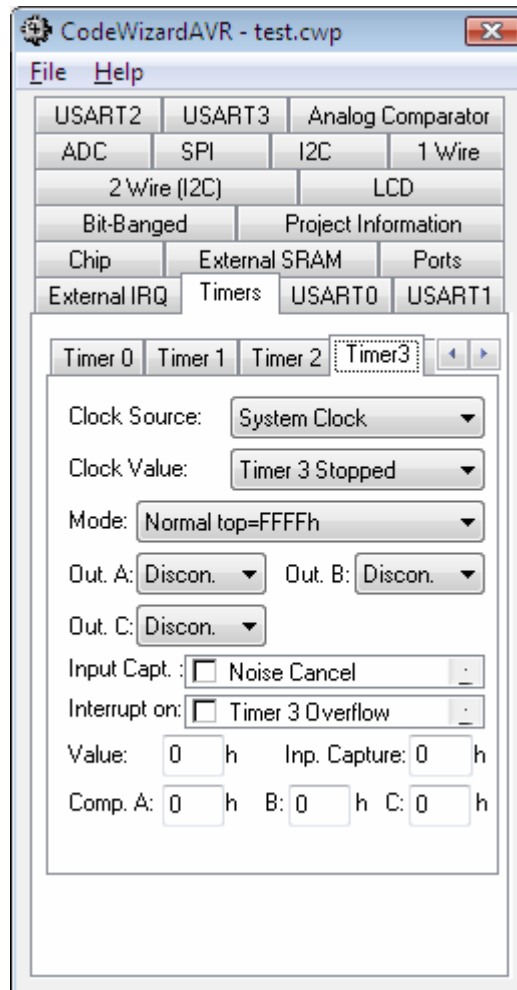

- **Clock Source** specifies the timer/counter 3 clock pulse source
- **Clock Value** specifies the timer/counter 3 clock frequency
- **Mode** specifies if the timer/counter 3 functioning mode
- **Out. A** specifies the function of the timer/counter 3 output A and depends of the functioning mode
- **Out. B** specifies the function of the timer/counter 3 output B and depends of the functioning mode
- **Out. C** specifies the function of the timer/counter 3 output C and depends of the functioning mode
- **Inp Capt.** specifies the timer/counter 3 capture trigger edge and if the noise canceler is to be used
- **Interrupt on** specifies if an interrupt is to be generated on timer/counter 3 overflow, input capture and compare match
- **Timer Value** specifies the initial value of timer/counter 3 at startup
- **Comp. A, B and C** specifies the initial value of timer/counter 3 output compare registers A, B and C.

CodeVisionAVR

If timer/counter 3 interrupts are used the following interrupt service routines may be defined by the CodeWizardAVR:

- **timer3_ovf_isr** for timer/counter overflow
- **timer3_comp_isr** or **timer3_compa_isr**, **timer3_compb_isr** and **timer3_compc_isr** for timer/counter output compare match
- **timer3_capt_isr** for timer/counter input capture

You must note that depending of the used AVR chip some of these options may not be present. For more information you must consult the corresponding Atmel data sheet.

By selecting the **Watchdog** tab you can configure the watchdog timer.

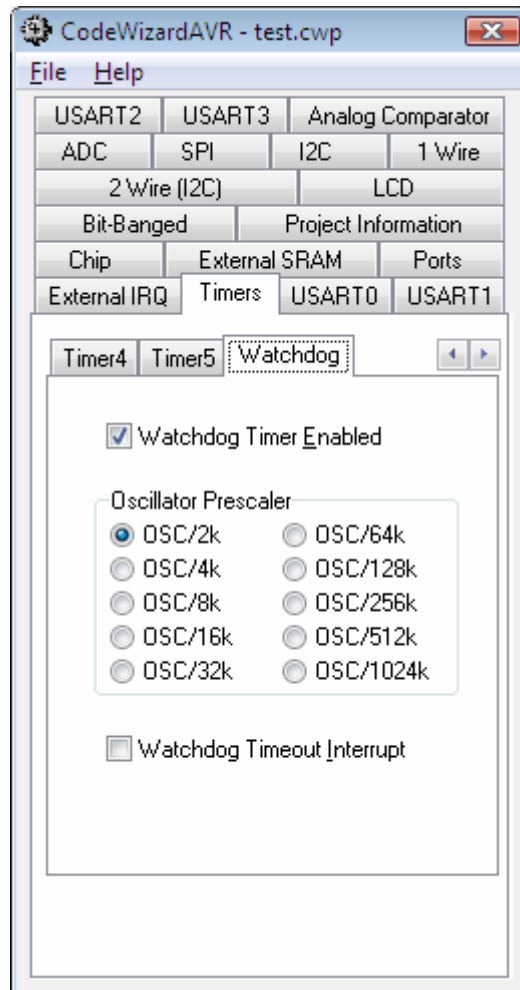

Checking the **Watchdog Timer Enabled** check box activates the watchdog timer. You will have then the possibility to set the watchdog timer's **Oscillator Prescaler**. If the **Watchdog Timeout Interrupt** check box is checked, an interrupt, serviced by the **wdt_timeout_isr** function, will be generated instead of reset if a timeout occurs.

In case the watchdog timer is enabled, you must include yourself the appropriate code sequences to reset it periodically. Example:

```
#asm("wdr")
```

For more information about the watchdog timer you must consult the Atmel data sheet for the chip that you use.

5.6 Setting the UART or USART

By selecting the **UART** tab of the CodeWizardAVR, you can specify the UART configuration.

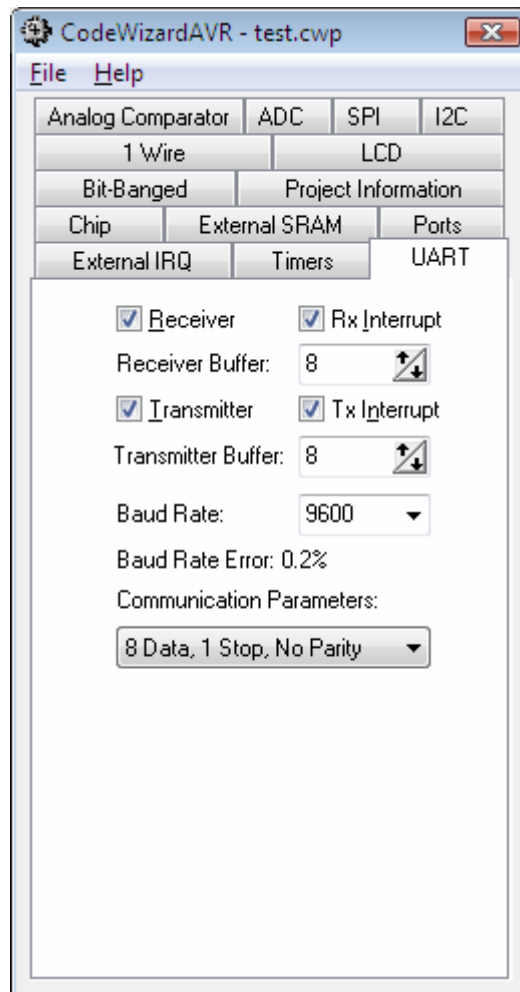

Checking the **Receiver** check box activates the UART receiver.

The receiver can function in the following modes:

- polled, the **Rx Interrupt** check box isn't checked
- interrupt driven circular buffer, the **Rx Interrupt** check box is checked.

In the interrupt driven mode you can specify the size of the circular buffer using the **Receiver Buffer** spinedit box.

Checking the **Transmitter** check box activates the UART transmitter.

The transmitter can function in the following modes:

- polled, the **Tx Interrupt** check box isn't checked
- interrupt driven circular buffer, the **Tx Interrupt** check box is checked.

In the interrupt driven mode you can specify the size of the circular buffer using the **Transmitter Buffer** spinedit box.

The communication Baud rate can be specified using the **UART Baud Rate** list box.

CodeWizardAVR will automatically set the UBRR according to the Baud rate and AVR chip clock frequency. The Baud rate error for these parameters will be calculated and displayed.

The **Communications Parameters** list box allows you to specify the number of data bits, stop bits and parity used for serial communication.

CodeVisionAVR

For devices featuring an **USART** there will be an additional **Mode** list box.

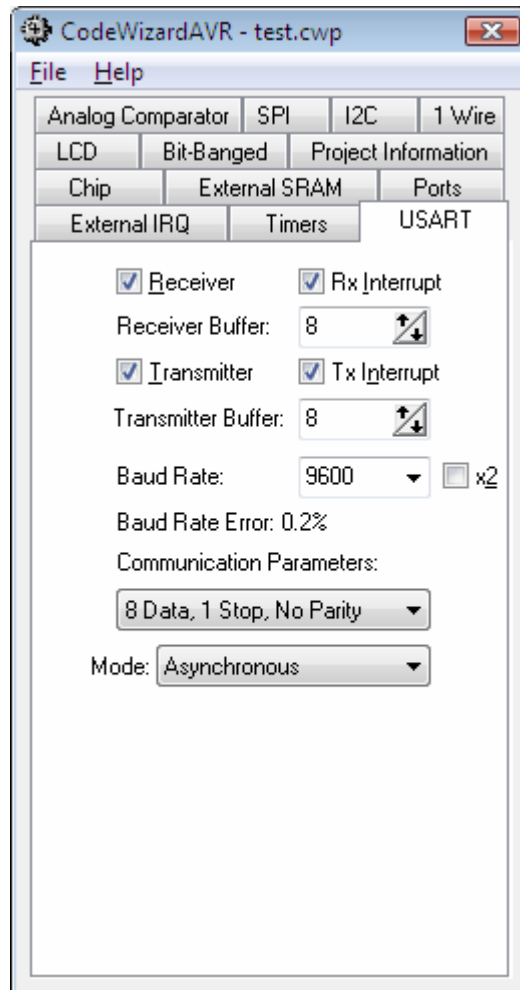

It allows you to specify the following communication modes:

- Asynchronous
- Synchronous Master, with the UCSRC register's UCPOL bit set to 0
- Synchronous Master, with the UCSRC register's UCPOL bit set to 1
- Synchronous Slave, with the UCSRC register's UCPOL bit set to 0
- Synchronous Slave, with the UCSRC register's UCPOL bit set to 1.

The serial communication is realized using the Standard Input/Output Functions **getchar**, **gets**, **scanf**, **putchar**, **puts** and **printf**.

For interrupt driven serial communication, CodeWizardAVR automatically redefines the basic **getchar** and **putchar** functions.

The receiver buffer is implemented using the global array **rx_buffer**.

The global variable **rx_wr_index** is the **rx_buffer** array index used for writing received characters in the buffer.

The global variable **rx_rd_index** is the **rx_buffer** array index used for reading received characters from the buffer by the **getchar** function.

The global variable **rx_counter** contains the number of characters received in **rx_buffer** and not yet read by the **getchar** function.

If the receiver buffers overflows the **rx_buffer_overflow** global bit variable will be set.

CodeVisionAVR

The transmitter buffer is implemented using the global array **tx_buffer**.

The global variable **tx_wr_index** is the **tx_buffer** array index used for writing in the buffer the characters to be transmitted.

The global variable **tx_rd_index** is the **tx_buffer** array index used for reading from the buffer the characters to be transmitted by the **putchar** function.

The global variable **tx_counter** contains the number of characters from **tx_buffer** not yet transmitted by the interrupt system.

For devices with 2 UARTs, respectively 2 USARTs, there will be two tabs present: **UART0** and **UART1**, respectively **USART0** and **USART1**.

The functions of configuration check and list boxes will be the same as described above.

The UART0 (USART0) will use the normal **putchar** and **getchar** functions.

In case of interrupt driven buffered communication, UART0 (USART0) will use the following variables: **rx_buffer0**, **rx_wr_index0**, **rx_rd_index0**, **rx_counter0**, **rx_buffer_overflow0**, **tx_buffer0**, **tx_wr_index0**, **tx_rd_index0**, **tx_counter0**.

The UART1 (USART1) will use the **putchar1** and **getchar1** functions.

In case of interrupt driven buffered communication, UART1 (USART1) will use the following variables: **rx_buffer1**, **rx_wr_index1**, **rx_rd_index1**, **rx_counter1**, **rx_buffer_overflow1**, **tx_buffer1**, **tx_wr_index1**, **tx_rd_index1**, **tx_counter1**.

All serial I/O using functions declared in **stdio.h**, will be done using UART0 (USART0).

5.7 Setting the Analog Comparator

By selecting the **Analog Comparator** tab of the CodeWizardAVR, you can specify the analog comparator configuration.

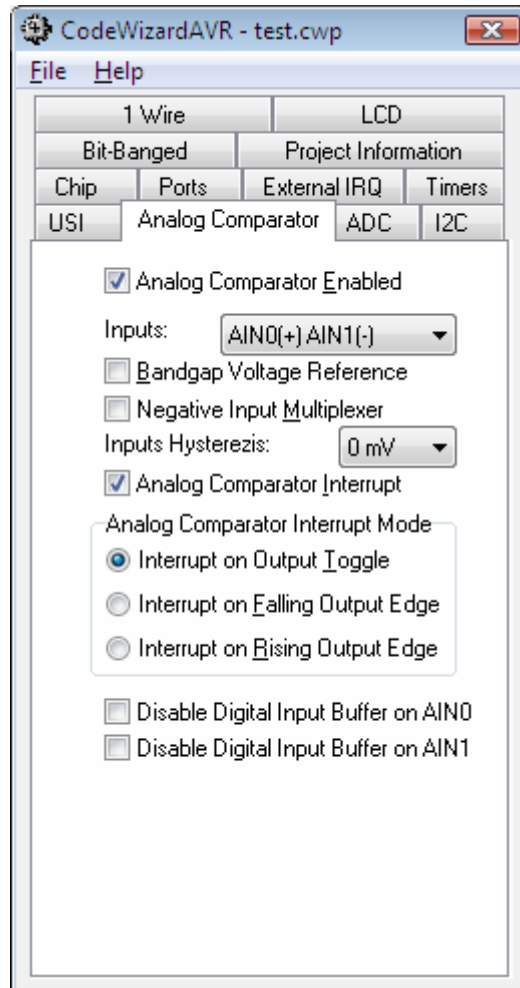

Checking the **Analog Comparator Enabled** check box enables the on-chip analog comparator. Checking the **Bandgap Voltage Reference** check box will connect an internal voltage reference to the analog comparator's positive input.

Checking the **Negative Input Multiplexer** check box will connect the analog comparator's negative input to the ADC's analog multiplexer.

If the **Negative Input Multiplexer** option is not enabled, the **Inputs** list box allows to select which of the ADC's analog multiplexer inputs will be connected to the analog comparator's positive and negative inputs.

The **Inputs Hysteresis** list box allows to select the amount of hysteresis of the analog comparator inputs.

If you want to generate interrupts if the analog comparator's output changes state, then you must check the **Analog Comparator Interrupt** check box.

The type of output change that triggers the interrupt can be specified in the **Analog Comparator Interrupt Mode** settings.

CodeVisionAVR

For some AVR chips the analog comparator's output may be used for capturing the state of timer/counter 1.

In this case the **Analog Comparator Input Capture** check box must be checked if present.

The **Disable Digital Input Buffer on AIN0**, respectively **Disable Digital Input Buffer on AIN1** check boxes, if checked, will deactivate the digital input buffers on the AIN0, respectively AIN1 pins, thus reducing the power consumption of the chip.

The corresponding bits in the PIN registers will always read 0 in this case.

Some of these check boxes may not be present on all the AVR chips.

If the analog comparator interrupt is enabled, the CodeWizardAVR will define the **ana_comp_isr** interrupt service routine.

5.8 Setting the Analog-Digital Converter

Some AVR chips contain an analog-digital converter (ADC). By selecting the **ADC** tab of the CodeWizardAVR, you can specify the ADC configuration.

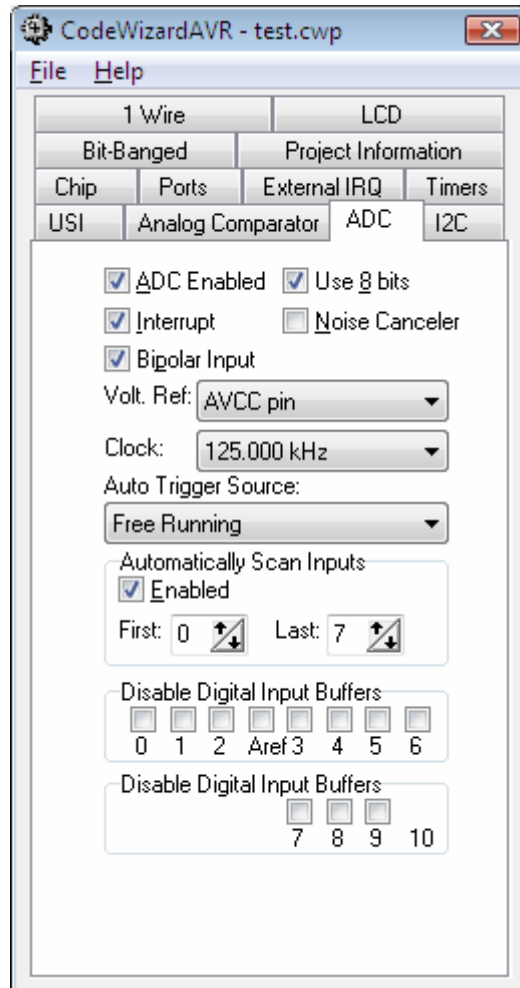

Checking the **ADC Enabled** check box enables the on-chip ADC.

On some AVR devices only the 8 most significant bits of the AD conversion result can be used. This feature is enabled by checking the **Use 8 bits** check box.

The ADC may be operated in bipolar mode if the **Bipolar Input** check box is checked.

Some AVR devices allow the ADC to use a high speed conversion mode, but with lower precision. This feature is enabled by checking the **High Speed** check box, if present.

If the ADC has an internal reference voltage source, than it can be selected using the **Volt. Ref.** list box or activated by checking the **ADC Bandgap** check box.

The ADC clock frequency can be selected using the **Clock** list box.

If you want to generate interrupts when the ADC finishes the conversion, then you must check the **Interrupt** check box.

CodeVisionAVR

If ADC interrupts are used you have the possibility to enable the following functions:

- by checking the **Noise Canceler** check box, the chip is placed in idle mode during the conversion process, thus reducing the noise induced on the ADC by the chip's digital circuitry
- by checking the **Automatically Scan Inputs Enabled** check box, the CodeWizardAVR will generate code to scan an ADC input domain and put the results in an array. The start, respectively the end, of the domain are specified using the **First Input**, respectively the **Last Input**, spinedit boxes.

Some AVR devices allow the AD conversion to be triggered by an event which can be selected using the **Auto Trigger Source** list box.

If the automatic inputs scanning is disabled, then a single analog-digital conversion can be executed using the function:

```
unsigned int read_adc(unsigned char adc_input)
```

This function will return the analog-digital conversion result for the input **adc_input**. The input numbering starts from 0.

If interrupts are enabled the above function will use an additional interrupt service routine **adc_isr**. This routine will store the conversion result in the **adc_data** global variable.

If the automatic inputs scanning is enabled, the **adc_isr** service routine will store the conversion results in the **adc_data** global array. The user program must read the conversion results from this array.

For some chips there is also the possibility to disable the digital input buffers on the inputs used by the ADC, thus reducing the power consumption of the chip.

This is accomplished by checking the corresponding **Disable Digital Input Buffers** check boxes.

If the **Automatically Scan Inputs** option is enabled, then the corresponding digital input buffers are automatically disabled for the ADC inputs in the scan range.

5.9 Setting the ATmega406 Voltage Reference

Some AVR chips, like the Atmega406, contain a low power precision bang-gap voltage reference, which can be configured by selecting the **Voltage Reference** tab of the CodeWizardAVR.

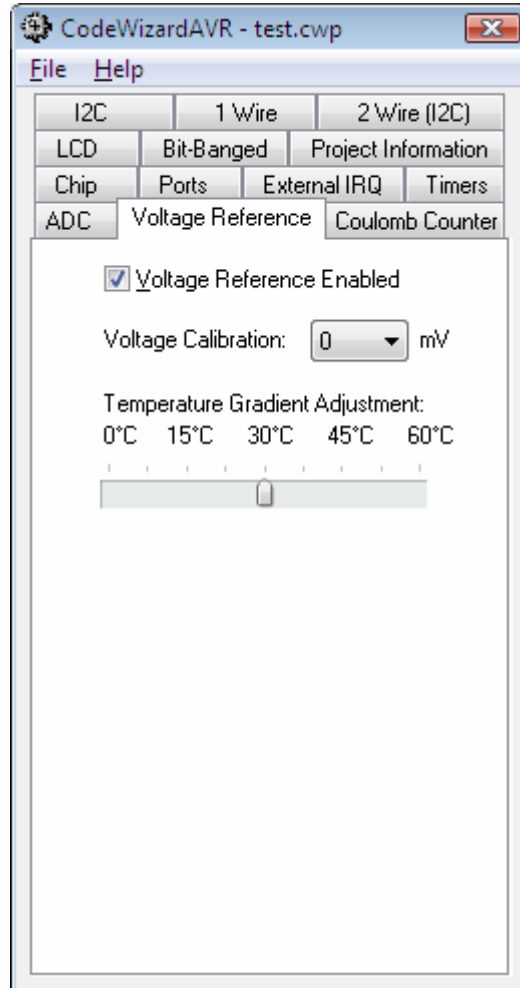

Checking the **Voltage Reference Enabled** check box enables the precision voltage reference. The **Voltage Calibration** list box allows for precision adjustment of the nominal value of the reference voltage in 2mV steps.

The **Temperature Gradient Adjustment** slider allows shifting the top of the V_{REF} versus temperature curve to the center of the temperature range of interest, thus minimizing the voltage drift in this range. The Atmega406 datasheet may be consulted for more details.

5.10 Setting the ATmega406 Coulomb Counter

The Atmega406 chip, contains a dedicated Sigma-Delta ADC optimized for Coulomb Counting to sample the charge or discharge current flowing through an external sense resistor R_s . This ADC can be configured by selecting the **Coulomb Counter** tab of the CodeWizardAVR.

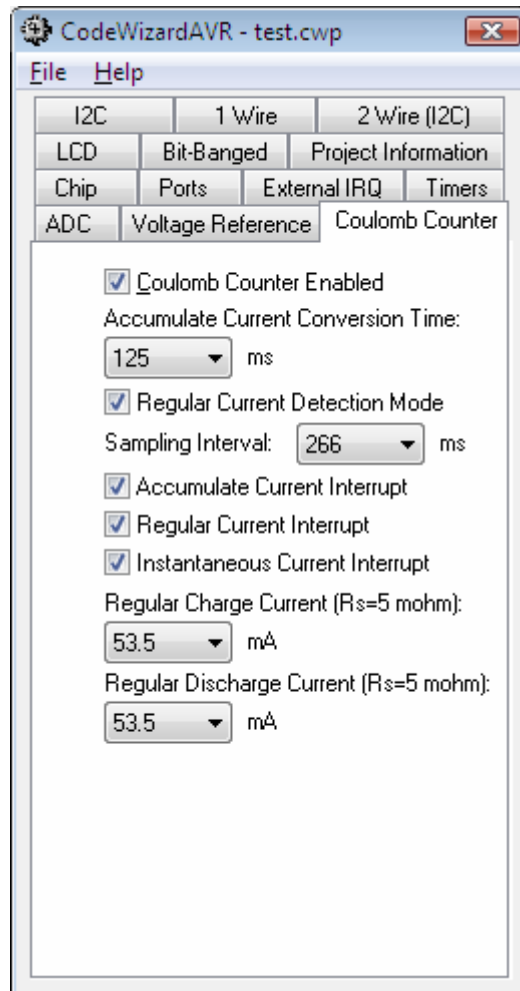

Checking the **Coulomb Counter Enabled** check box enables the Coulomb Counter Sigma-Delta ADC.

The **Accumulate Current Conversion Time** list box specifies the conversion time for the Accumulate Current output.

The **Regular Current Detection Mode** check box specifies that the Coulomb Counter will repeatedly do one instantaneous current conversion, before it is turned off for a timing interval specified by the **Sampling Interval** list box.

The interval selected using the above-mentioned list box includes a sampling time, having a typical value of 16ms.

The **Accumulate Current Interrupt** check box enable the generation of an interrupt after the accumulate current conversion has completed. This interrupt is serviced by the `ccadc_acc_isr` ISR.

The **Regular Current Interrupt** check box enable the generation of an interrupt when the absolute value of the result of the last AD conversion is greater, or equal to, the values of the CADRCC and CADRDC registers. This interrupt is serviced by the `ccadc_reg_cur_isr` ISR.

CodeVisionAVR

The **Instantaneous Current Interrupt** check box enables the generation of an interrupt when an instantaneous current conversion has completed. This interrupt is serviced by the **ccadc_conv_isr** ISR.

The **Regular Charge Current**, respectively **Regular Discharge Current**, list boxes determine the threshold levels for the *regular charge*, respectively *regular discharge* currents, setting the values for the CADRCC, respectively CADRDC, registers used for generating the *Regular Current Interrupt*.

The Atmega406 datasheet may be consulted for more details about the Coulomb Counter.

5.11 Setting the SPI Interface

By selecting the **SPI** tab of the CodeWizardAVR, you can specify the SPI interface configuration.

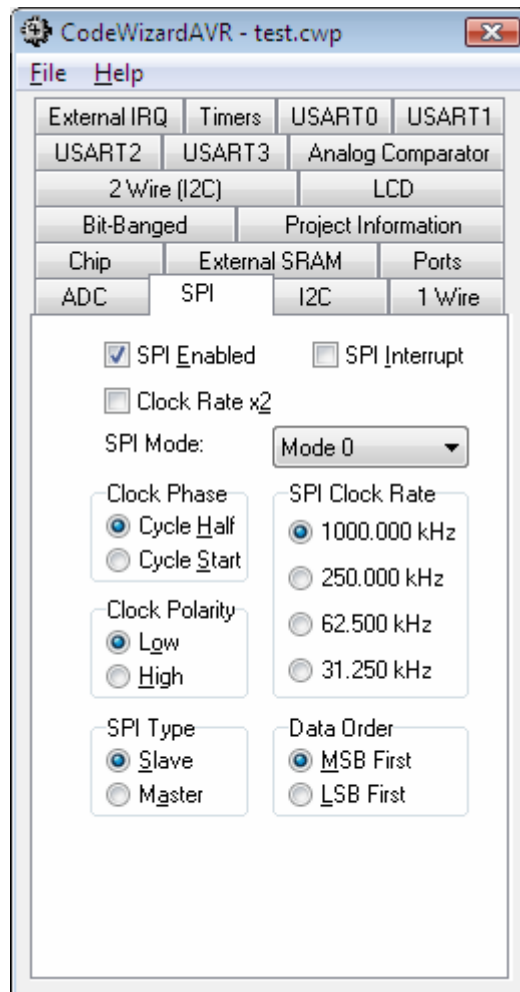

Checking the **SPI Enabled** check box enables the on-chip SPI interface.

If you want to generate interrupts upon completion of a SPI transfer, then you must check the **SPI Interrupt** check box.

You have the possibility to specify the following parameters:

- **SPI Clock Rate** used for the serial transfer
- **Clock Phase**: the position of the SCK strobe signal edge relative to the data bit
- **Clock Polarity**: low or high in idle state
- **SPI Type**: the AVR chip is master or slave
- **Data Order** in the serial transfer.

Checking the **Clock Rate x2** check box, available for some AVR chips, will double the **SPI Clock Rate**.

For communicating through the SPI interface, with disabled SPI interrupt, you must use the **SPI Functions**.

If the SPI interrupt is enabled, you must use the **spi_isr** interrupt service routine, declared by the CodeWizardAVR.

5.12 Setting the Universal Serial Interface - USI

By selecting the **USI** tab of the CodeWizardAVR, you can specify the USI configuration. The USI operating mode can be selected using the **Mode** list box. One of the USI operating modes is the **Three Wire (SPI)** mode:

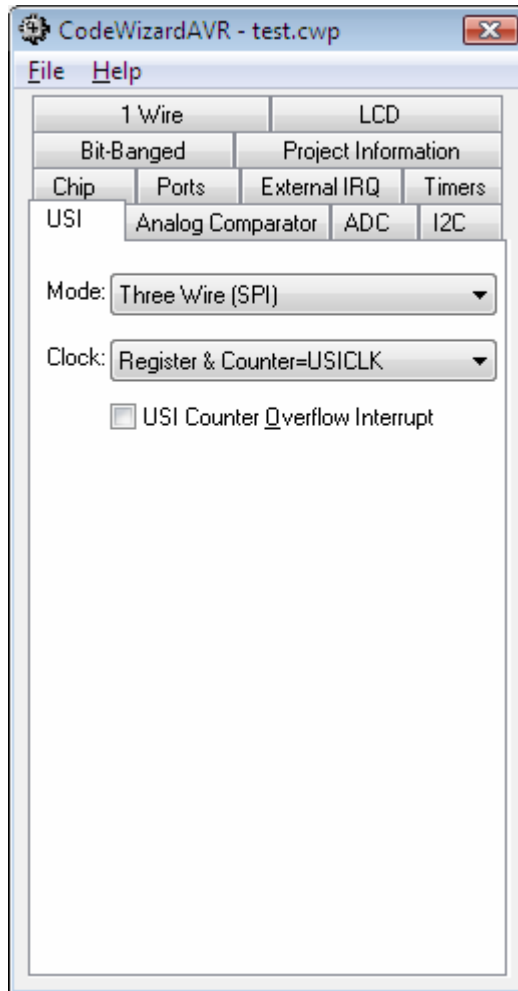

CodeVisionAVR

The USI can also operate in the **Two Wire (I2C)** mode:

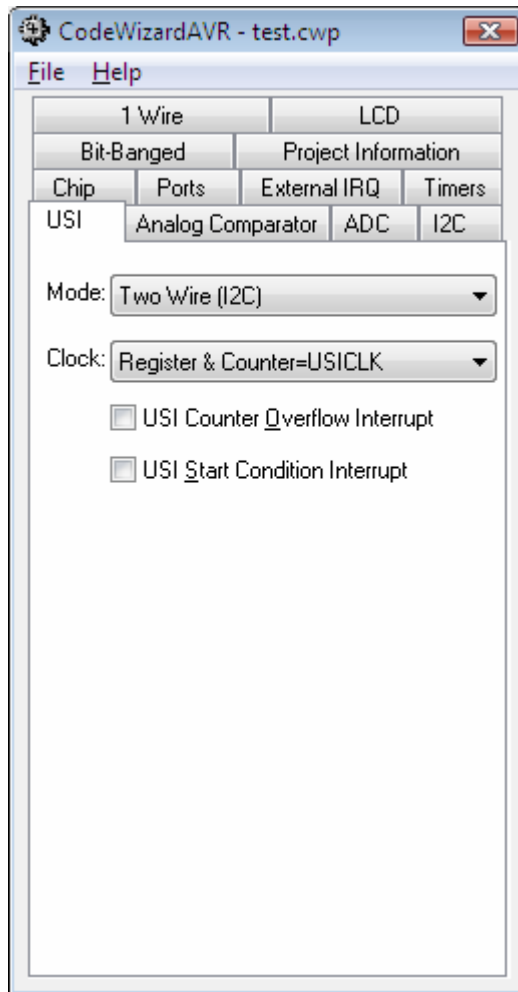

The **Shift Reg. Clock** list box sets the clock source for the USI Shift Register and Counter.

As both the USI Shift Register and Counter are clocked from the same clock source, the USI Counter may be used to count the number of received or transmitted bits and generate an overflow interrupt when the data transfer is complete.

Checking the **USI Counter Overflow Interrupt** check box will generate code for an interrupt service routine that will be executed upon the overflow of the USI Counter.

If the **USI Start Condition Interrupt** check box is checked then the CodeWizardAVR will generate code for an interrupt service routine that will be executed when a Start Condition is detected on the I2C bus in USI **Two Wire** operating mode.

CodeVisionAVR

5.13 Setting the I²C Bus

By selecting the I²C tab of the CodeWizardAVR, you can specify the I²C bus configuration.

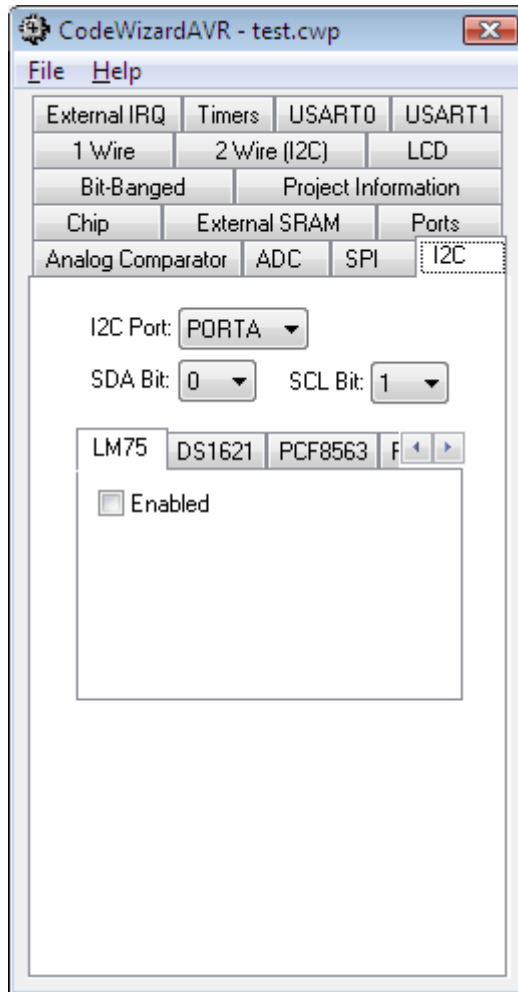

Using the **I²C Port** list box you can specify which port is used for the implementation of the I²C bus. The **SDA Bit** and **SCL Bit** list boxes allow you to specify which port bits the I²C bus uses.

5.13.1 Setting the LM75 devices

If you use the LM75 temperature sensor, you must select the **LM75** tab and check the **LM75 Enabled** check box.

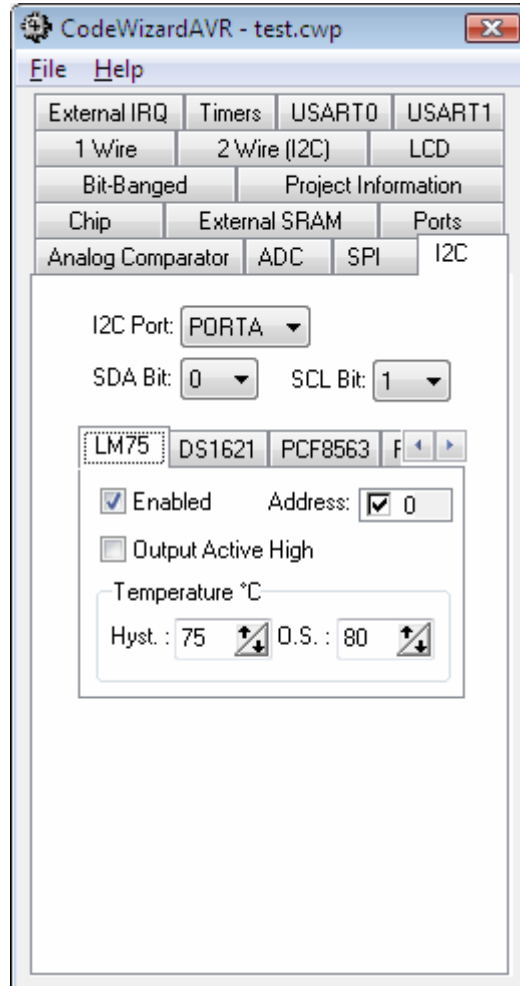

The **LM75 Address** list box allows you to specify the 3 lower bits of the I²C addresses of the LM75 devices connected to the bus. Maximum 8 LM75 devices can be used.

The **Output Active High** check box specifies the active state of the LM75 O.S. output.

The **Hyst.**, respectively **O.S.**, spinedit boxes specify the hysteresis, respectively O.S. temperatures.

The LM75 devices are accessed through the **National Semiconductor LM75 Temperature Sensor Functions**.

CodeVisionAVR

5.13.2 Setting the DS1621 devices

If you use the DS1621 thermometer/thermostat, you must select the **DS1621** tab and check the **DS1621 Enabled** check box.

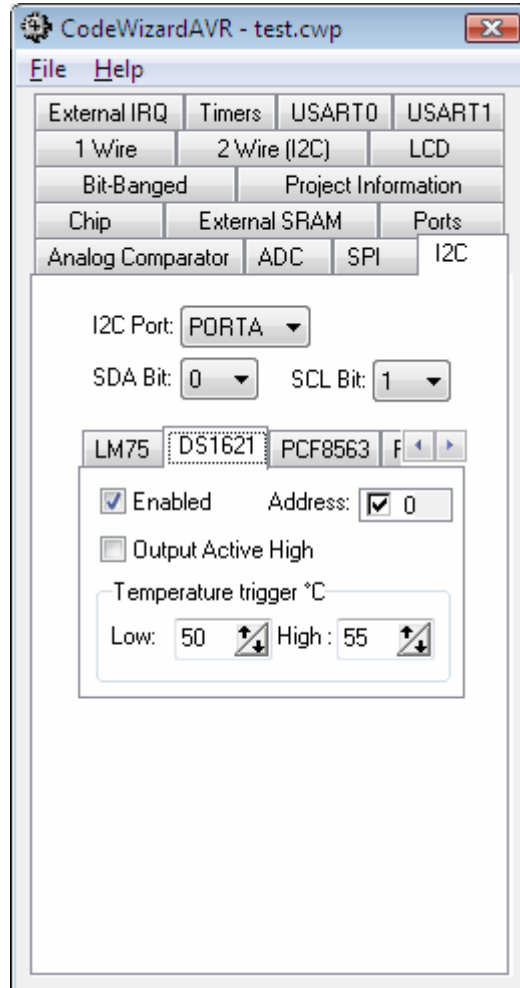

The **Output Active High** check box specifies the active state of the DS1621 Tout output. The **Low**, respectively **High**, spinedit boxes specify the low, respectively high temperatures trigger temperatures for the Tout output.

The DS1621 devices are accessed through the **Maxim/Dallas Semiconductor DS1621 Thermometer/Thermostat** functions.

5.13.3 Setting the PCF8563 devices

If you use the PCF8563 RTC, you must select the PCF8563 tab and check the PCF8563 Enabled check box.

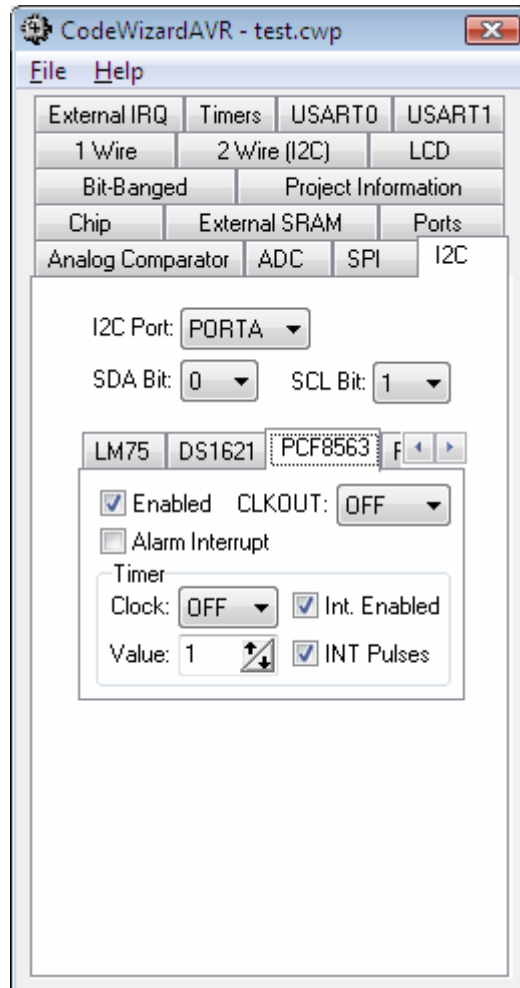

The **CLKOUT** list box specifies the frequency of the pulses on the CLKOUT output.

The **Alarm Interrupt** check box enables the generation of interrupts, on the INT pin, when the alarm conditions are met.

The **Timer|Clock** list box specifies the countdown frequency of the PCF8563 Timer.

If the **Int. Enabled** check box is checked, an interrupt will be generated when the Timer countdown value will be 0.

If the **INT Pulses** check box is checked, the INT pin will issue short pulses when the Timer countdown value reaches 0.

The **Timer|Value** spinedit box specifies the Timer reload value when the countdown reaches 0.

The PCF8563 devices are accessed through the **Philips PCF8563 Real Time Clock Functions**.

CodeVisionAVR

5.13.4 Setting the PCF8583 devices

If you use the PCF8583 RTC, you must select the **PCF8583** tab and check the **PCF8583 Enabled** check box.

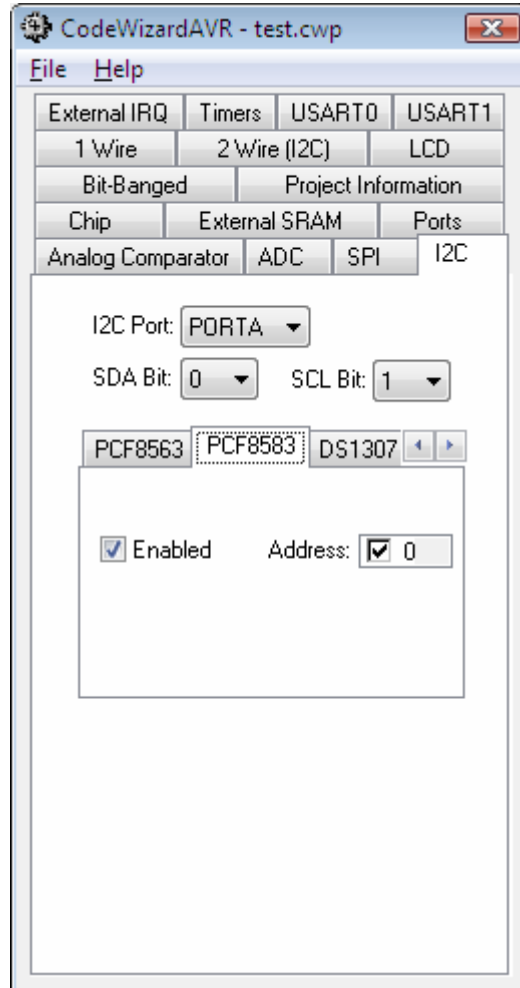

The **PCF8583 Address** list box allows you to specify the low bit of the I²C addresses of the PCF8583 devices connected to the bus. Maximum 2 PCF8583 devices can be used.

The PCF8583 devices are accessed through the **Philips PCF8583 Real Time Clock Functions**.

5.13.5 Setting the DS1307 devices

If you use the DS1307 RTC, you must select the **DS1307** tab and check the **DS1307 Enabled** check box.

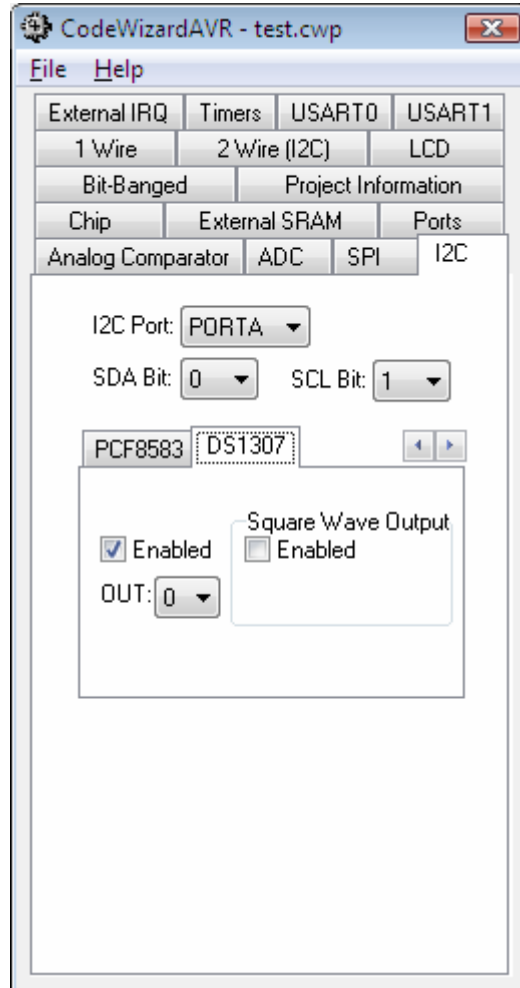

The DS1307 device is accessed through the **Maxim/Dallas Semiconductor DS1307 Real Time Clock Functions**.

In case the square wave signal output is disabled, the state of the SQW/OUT pin can be specified using the **OUT** list box.

CodeVisionAVR

By checking the **Square Wave Output Enabled** check box a square wave signal will be available on the DS1307's SQW/OUT pin. The frequency of the square wave can be selected using the **Freq.** list box:

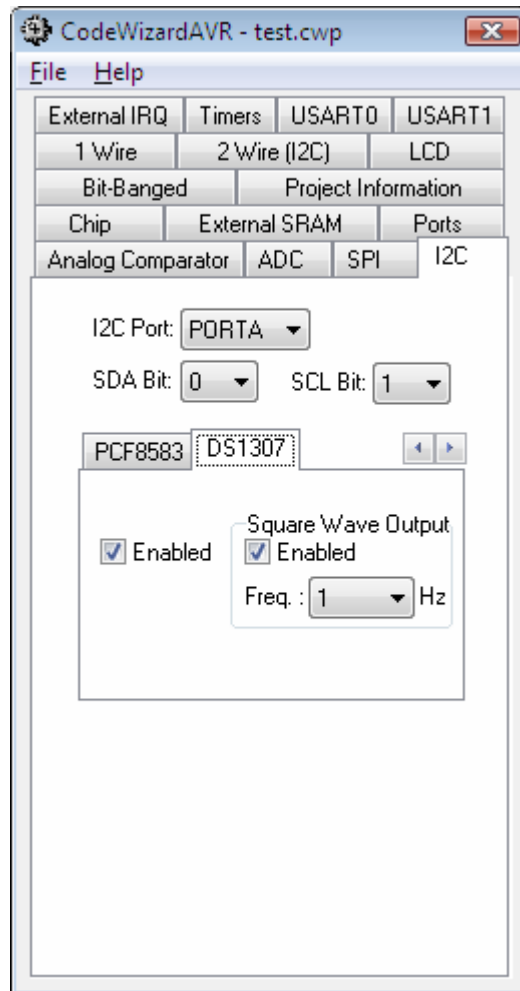

CodeVisionAVR

5.14 Setting the 1 Wire Bus

By selecting the **1 Wire** tab of the CodeWizardAVR, you can specify the 1 Wire bus configuration.

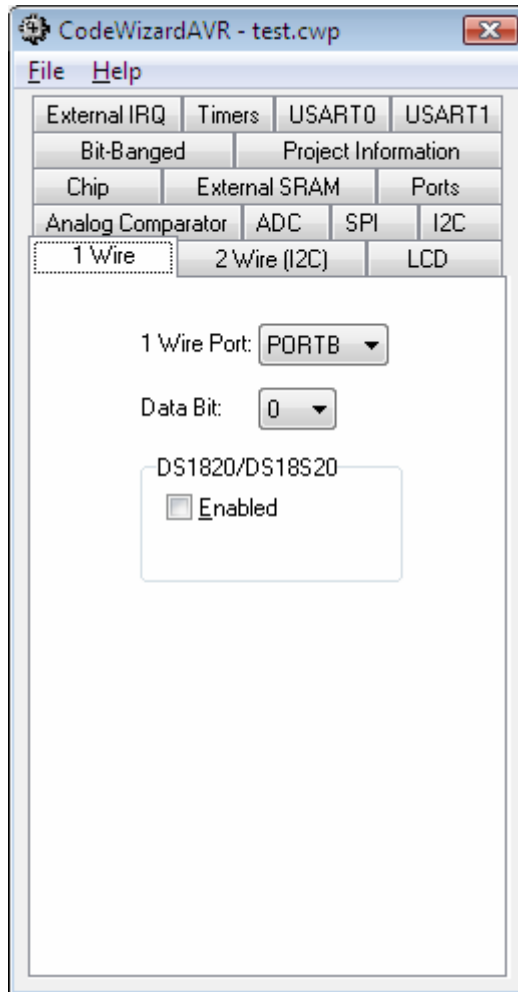

Using the **1 Wire Port** list box you can specify which port is used for the implementation of the 1 Wire bus.

The **Data Bit** list box allows you to specify which port bit the 1 Wire bus uses.

CodeVisionAVR

If you use the DS1820/DS18S20 temperature sensors, you must check the **DS1820/DS18S20 Enabled** check box.

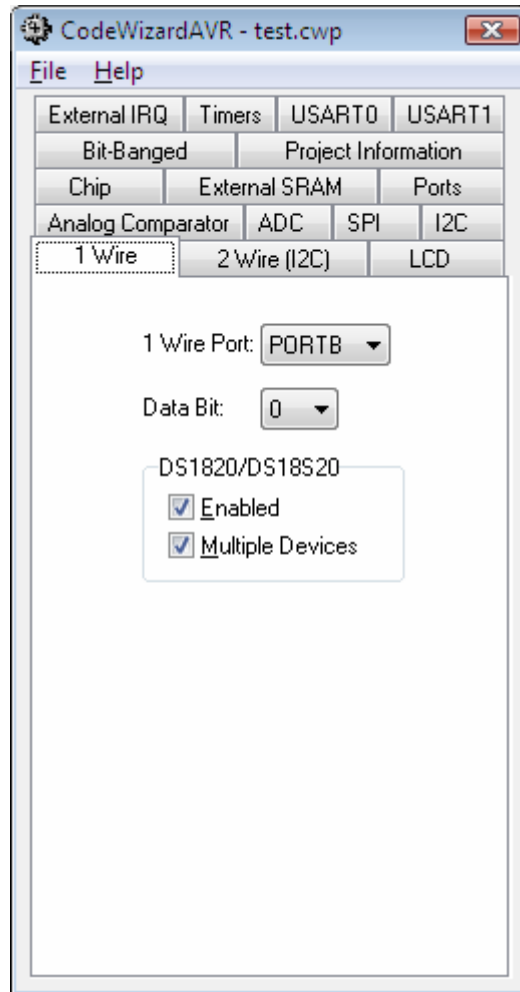

If you use several DS1820/DS18S20 devices connected to the 1 Wire bus, you must check the **Multiple Devices** check box. Maximum 8 DS1820/DS18S20 devices can be connected to the bus. The ROM codes for these devices will be stored in the `ds1820_rom_codes` array.

The DS1820/DS18S20 devices can be accessed using the **Maxim/Dallas Semiconductor DS1820/DS18S20 Temperature Sensors Functions**.

5.15 Setting the 2 Wire Bus

By selecting the **2 Wire (I²C)** tab of the CodeWizardAVR, you can specify the 2 Wire bus interface configuration.

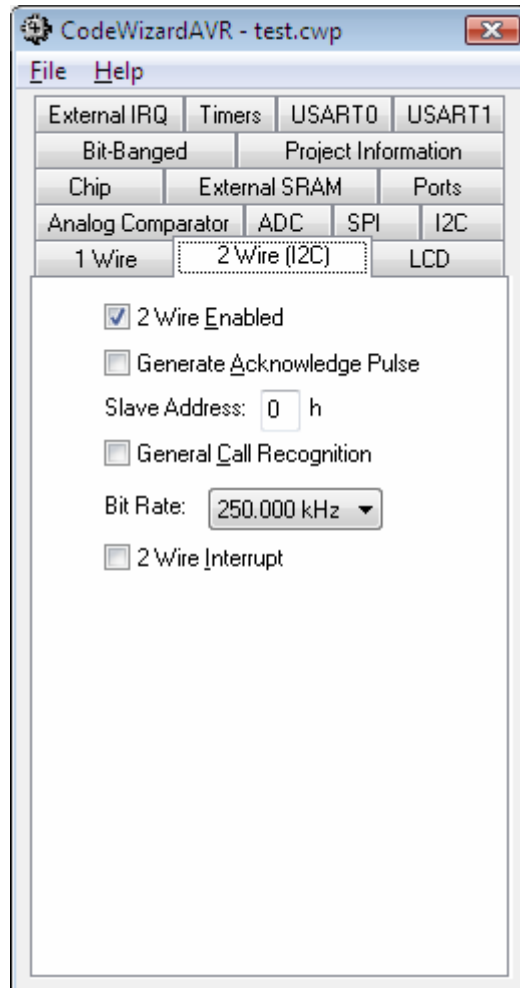

The AVR chip's 2 Wire interface can be enabled by checking the **2 Wire Enabled** check box. If the **Generate Acknowledge Pulse** check box is checked the ACK pulse on the 2 Wire bus is generated if one of the following conditions is met:

- the device's own slave address has been received;
- a General Call has been received and the **General Call Recognition** check box is checked;
- a data byte has been received in master receiver or slave receiver mode.

If the **Generate Acknowledge Pulse** check box is not checked, the chip's 2 Wire interface is virtually disconnected from the 2 Wire bus. This check box will set the state of the TWEA bit of the TWCR register.

The **Slave Address** edit box sets the slave address of the 2 Wire serial bus unit. This address must be specified in hexadecimal and will be used to initialize the bits 1..7 of the TWAR register.

Checking the **General Call Recognition** check box, enables the recognition of the General Call given over the 2 Wire bus. This check box will set the state of the TWGCE bit of the TWAR register.

The **Bit Rate** list box allows you to specify maximum frequency of the pulses on the SCL 2 Wire bus line. It will affect the value of the TWBR register.

CodeVisionAVR

As both the receiver and transmitter may stretch the duration of the low period of the SCL line, when waiting for response, the frequency of the pulses may be lower than specified.

If the **2 Wire Interrupt** check box is checked, the 2 Wire interface will generate interrupts. These interrupts will be serviced by the `twi_isr` function.

5.16 Setting the CAN Controller

By selecting the **CAN** tab of the CodeWizardAVR, you can specify the CAN interface configuration.

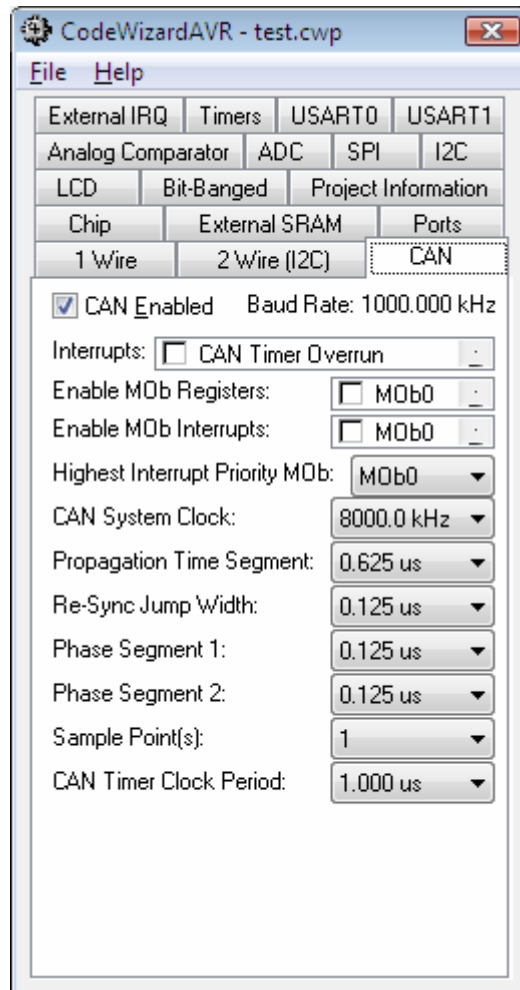

The AVR chip's CAN interface can be enabled by checking the **CAN Enabled** check box. The **Interrupts** list box allows enabling/disabling the following interrupts generated by the CAN controller:

- **CAN Timer Overrun** interrupt, serviced by the `can_timer_isr` function
- **General Errors** (bit error, stuff error, CRC error, form error, acknowledge error) interrupt, serviced by the `can_isr` function
- **Frame Buffer Full** interrupt, serviced by the `can_isr` function
- **MOb Errors** interrupt, serviced by the `can_isr` function
- **Transmit** completed OK interrupt, serviced by the `can_isr` function
- **Receive** completed OK interrupt, serviced by the `can_isr` function
- **Bus Off** interrupt, serviced by the `can_isr` function
- **All** interrupts, except Timer Overrun, serviced by the `can_isr` function

CodeVisionAVR

The **Enable MOB Registers** list box allows for individual enabling/disabling of the CAN Message Object registers.

The **Enable MOB Interrupts** list box allows for enabling/disabling the interrupts generated by individual Message Object registers.

The **Highest Interrupt Priority MOB** list box allows selecting the Message Object register that has the highest interrupt priority.

The **CAN System Clock** list box allows selecting the frequency of the CAN controller system clock.

The **Propagation Time Segment** list box allows for compensation of physical delay times within the network. The duration of the propagation time segment must be twice the sum of the signal propagation time on the bus line, the input comparator delay and the output driver delay.

The **Re-Sync Jump Width** list box allows for compensation of phase shifts between clock oscillators of different bus controllers, by controller re-synchronization on any relevant signal edge of the current transmission.

The **Phase Segment 1** and **Phase Segment 2** list boxes allow for compensation of phase edge errors.

The **Sample Point(s)** list box allows selecting the number of times (1 or 3) the bus is sampled.

The **CAN Timer Clock Period** list box allows selecting the period of the CAN timer clock pulses.

The **CAN Baud Rate** is calculated based on the durations of the **CAN System Clock**, **Propagation Time Segment**, **Phase Segment 1** and **Phase Segment 2** parameters.

If the CAN Baud Rate value is correct it's value is displayed in black color, otherwise it is displayed in red and must be corrected by modifying the above mentioned parameters.

5.17 Setting the ATmega169/329/3290/649/6490 LCD Controller

By selecting the **LCD Controller** tab of the CodeWizardAVR, you can specify the configuration of the LCD controller built in the ATmega169/329/3290/649/6490 chips.

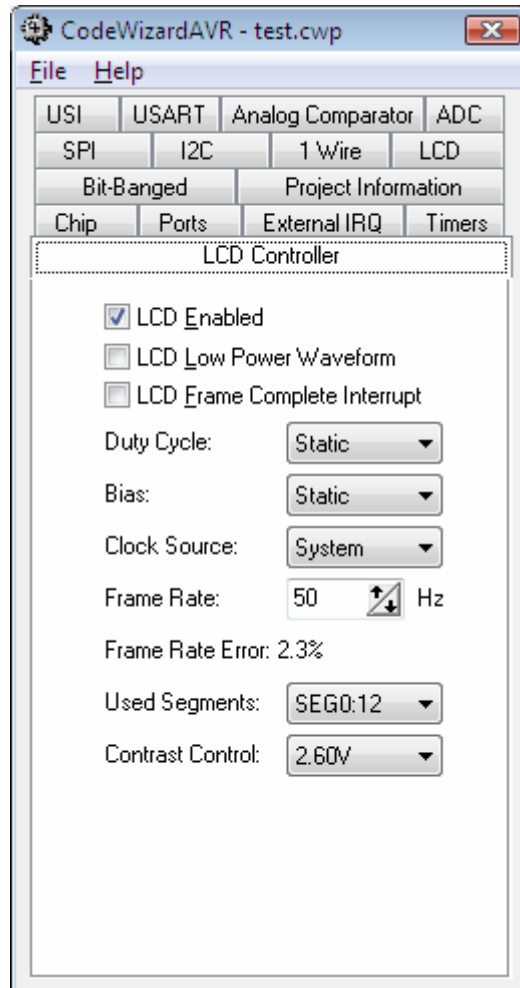

The ATmega169V/L on chip LCD controller can be enabled by checking the **LCD Enabled** check box. By checking the **LCD Low Power Waveform** check box, the low power waveform will be outputted on the LCD pins. This allows reducing the power consumption of the LCD.

If the **LCD Frame Complete Interrupt** check box is checked, the LCD controller will generate an interrupt at the beginning of a new frame. In low power waveform mode this interrupt will be generated every second frame. The frame complete interrupt will be serviced by the `lcd_sof_isr` function.

The **LCD Duty Cycle** list box selects one of the following duty cycles: Static, 1/2, 1/3 or 1/4.

The **LCD Bias** list box selects the 1/3 or 1/2 bias. Please refer to the documentation of the LCD manufacturer for bias selection.

The **Clock Source** list box selects the system clock or an external asynchronous clock as the LCD controller clock source.

The **Frame Rate** spin edit allows specifying the LCD frame rate.

The LCD Frame Rate Register (LCDFRR) is initialized based on the frequency of the clock source and the obtainable frame rate, that is as close as possible to the one that was specified.

CodeVisionAVR

The **Frame Rate Error** is calculated based on the specified **Frame Rate** and the real one obtained from LCDFRR.

The **Used Segments** list box setting determine the number of port pins used as LCD segment drivers. The **Contrast Control** list box specifies the maximum voltage on LCD segment and common pins **VLCD**. The **VLCD** range is between 2.60 and 3.35 Vcc.

5.18 Setting the LCD

By selecting the **LCD** tab of the CodeWizardAVR, you can specify the LCD configuration.

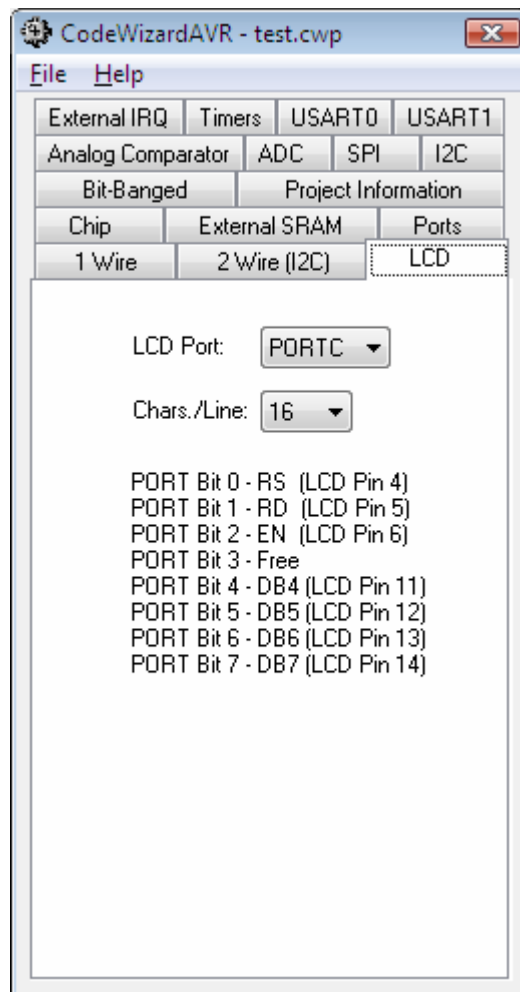

Using the **LCD Port** list box you can specify which port is used for connecting the alphanumeric LCD. The **Chars./Line** list box allows you to specify the number of characters per display line. This value is used by the **lcd_init** function. The LCD can be accessed using the standard **LCD Functions**.

5.19 Setting the USB Controller

By selecting the **USB** tab of the CodeWizardAVR, you can specify the configuration of the USB controller for the AT90USB646, AT90USB647, AT90USB1286 and AT90USB1287 chips. The USB controller can operate in two modes: **Device** and **Host**, specified using the **Operating Mode** list box.

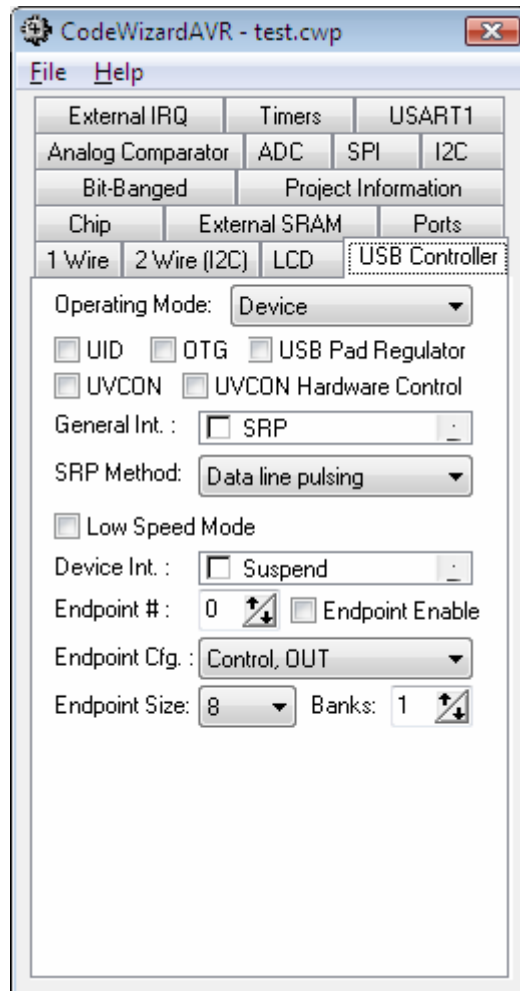

The operation of the USB controller in both modes and the various settings for them are described in detail in the AT90USB datasheet.

5.20 Setting Bit-Banged Peripherals

By selecting the **Bit-Banged** tab of the CodeWizardAVR, you can specify the configuration of the peripherals connected using the bit-banging method.

If you use the DS1302 RTC, you must select the **DS1302** tab.

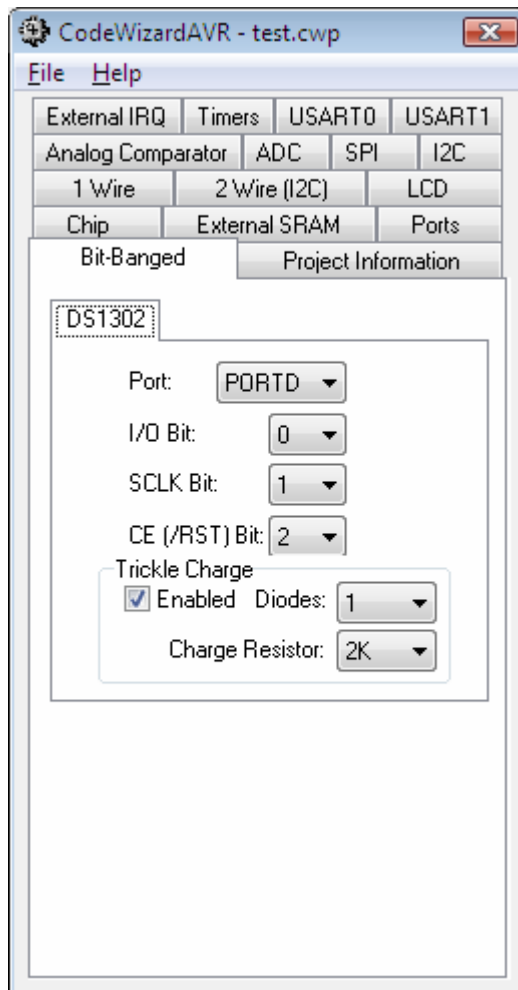

Using the **Port** list box you can specify which port is used for connecting with the DS1302. The **I/O Bit**, **SCLK Bit** and **/RST Bit** list boxes allow you to specify which port bits are used for this.

The DS1302's trickle charge function can be activated by checking the **Trickle Charge|Enabled** check box.

The number of diodes, respectively the charge resistor value, can be specified using the **Trickle Charge|Diodes**, respectively **Trickle Charge|Resistors**, list boxes.

The DS1302 device is accessed through the **Maxim/Dallas Semiconductor DS1302 Real Time Clock Functions**.

CodeVisionAVR

5.21 Specifying the Project Information

By selecting the **Project Information** tab, you can specify the information placed in the comment header, located at the beginning of the C source file produced by CodeWizardAVR.

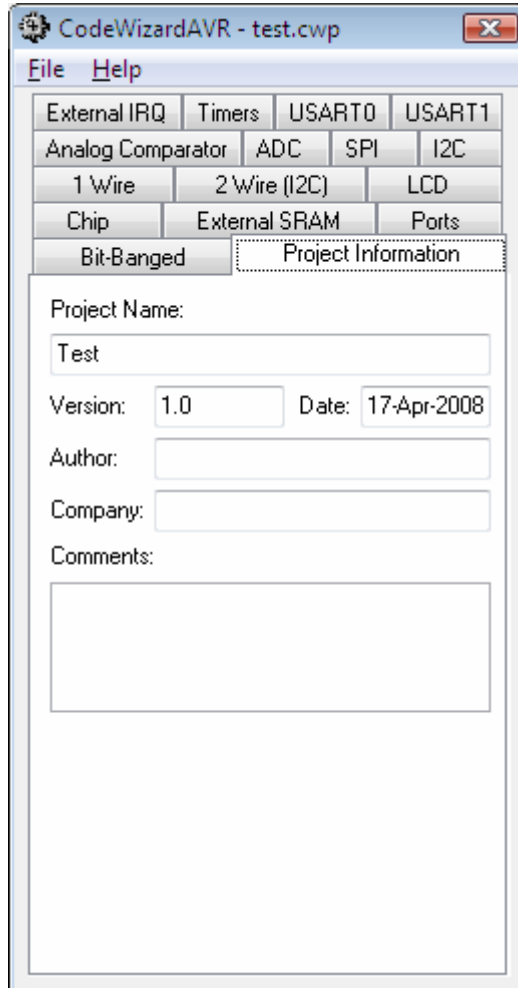

You can specify the **Project Name**, **Date**, **Author**, **Company** and **Comments**.

6. License Agreement

6.1 Software License

The use of CodeVisionAVR indicates your understanding and acceptance of the following terms and conditions. This license shall supersede any verbal or prior verbal or written, statement or agreement to the contrary. If you do not understand or accept these terms, or your local regulations prohibit "after sale" license agreements or limited disclaimers, you must cease and desist using this product immediately.

This product is © Copyright 1998-2009 by Pavel Haiduc and HP InfoTech S.R.L., all rights reserved. International copyright laws, international treaties and all other applicable national or international laws protect this product. This software product and documentation may not, in whole or in part, be copied, photocopied, translated, or reduced to any electronic medium or machine readable form, without prior consent in writing, from HP InfoTech S.R.L. and according to all applicable laws. The sole owners of this product are Pavel Haiduc and HP InfoTech S.R.L.

6.2 Liability Disclaimer

This product and/or license is provided as is, without any representation or warranty of any kind, either express or implied, including without limitation any representations or endorsements regarding the use of, the results of, or performance of the product, its appropriateness, accuracy, reliability, or correctness.

The user and/or licensee assume the entire risk as to the use of this product.

Pavel Haiduc and HP InfoTech S.R.L. do not assume liability for the use of this program beyond the original purchase price of the software. In no event will Pavel Haiduc or HP InfoTech S.R.L. be liable for additional direct or indirect damages including any lost profits, lost savings, or other incidental or consequential damages arising from any defects, or the use or inability to use these programs, even if Pavel Haiduc or HP InfoTech S.R.L. have been advised of the possibility of such damages.

6.3 Restrictions

You may not use, copy, modify, translate, or transfer the programs, documentation, or any copy except as expressly defined in this agreement. You may not attempt to unlock or bypass any "copy-protection" or authentication algorithm utilized by the program. You may not remove or modify any copyright notice or the method by which it may be invoked.

6.4 Operating License

You have the non-exclusive right to use the program only by a single person, on a single computer at a time. You may physically transfer the program from one computer to another, provided that the program is used only by a single person, on a single computer at a time. In-group projects where multiple persons will use the program, you must purchase an individual license for each member of the group.

Use over a "local area network" (within the same locale) is permitted provided that only a single person, on a single computer uses the program at a time. Use over a "wide area network" (outside the same locale) is strictly prohibited under any and all circumstances.

6.5 Back-up and Transfer

You may make one copy of the program solely for "back-up" purposes, as prescribed by international copyright laws. You must reproduce and include the copyright notice on the back-up copy. You may transfer the product to another party only if the other party agrees to the terms and conditions of this agreement, and completes and returns registration information (name, address, etc.) to Pavel Haiduc and HP InfoTech S.R.L. within 30 days of the transfer. If you transfer the program you must at the same time transfer the documentation and back-up copy, or transfer the documentation and destroy the back-up copy. You may not retain any portion of the program, in any form, under any circumstance.

6.6 Terms

This license is effective until terminated. You may terminate it by destroying the program, the documentation and copies thereof. This license will also terminate if you fail to comply with any terms or conditions of this agreement. You agree upon such termination to destroy all copies of the program and of the documentation, or return them to Pavel Haiduc or HP InfoTech S.R.L. for disposal. Note that by registering this product you give Pavel Haiduc and HP InfoTech S.R.L. permission to reference your name in product advertisements.

6.7 Other Rights and Restrictions

All other rights and restrictions not specifically granted in this license are reserved by Pavel Haiduc and HP InfoTech S.R.L.

7. Technical Support and Updates

Registered users of commercial versions of CodeVisionAVR receive one-year of free updates and technical support starting from the date of license purchase.

The technical support is provided by e-mail in English or French languages.
The e-mail support address is: **office@hpinfotech.com**

8. Contact Information

HP InfoTech S.R.L. can be contacted at:

HP INFOTECH S.R.L.
BD. DECEBAL NR. 3
BL. S12B, SC. 2, AP. 29
SECTOR 3
BUCHAREST
ROMANIA

phone: +(40)-213261875

fax: +(40)-213261876

GSM: +(40)-723469754

e-mail: office@hpinfotech.com

Internet: <http://www.hpinfotech.com>

<http://www.hpinfotech.biz>

<http://www.hpinfotech.eu>

<http://www.hpinfotech.ro>