



INNOVATIVE DISPLAY TECHNOLOGIES

17171 MURPHY AVENUE

IRVINE, CALIFORNIA 92614-5915

P: 949-417-8070/F: 949-417-8075

E-mail: info@shellyinc.com

Website: www.shellyinc.com

Specification

Part Number : SCA04330-BFN-LNC

Customer : _____

APPROVED BY: (FOR CUSTOMER USE ONLY)	PCB VERSION:	DATE:
--------------------------------------------------	---------------------	--------------

SOLD BY	APPROVED BY	CHECKED BY	ISSUE DATE

MODLE NO :

DOC. FIRST ISSUE

RECORDS OF REVISION

VERSION	DATE	REVISED PAGE NO.	SUMMARY
0	2009.5.26		First issue

Contents

1. Module Classification Information
2. Block Diagram
3. Electrical Characteristics
4. Absolute Maximum Ratings
5. Interface Pin Function
6. DC CHARACTERISTICS
7. AC Characteristics
8. Data transfer order Setting
9. Register Depiction
10. OPTICAL CHARACTERISTIC
11. Contour Drawing
12. LED driving conditions
14. Inspection specification

1.Module Classification Information

SCA04330 – B F N - L N C

① ② ③ ④ ⑤ ⑥ ⑦ ⑧ ⑨ ⑩ ⑪

- ① Brand : Shelly Associates Inc.
- ② Display Type : SCA → TFT Type
- ③ Display Size : 4.3” TFT
- ④ Model serials no.
- ⑤ Backlight Type : L→ LED, White
- ⑥ LCD Polarize Type/ Temperature range/ View direction F→ Transmissive, B→ W. T, 6:00
- ⑦ B: TFT+FR+CONTROL BOARD
- ⑧ Solution: E : 480272
- ⑨ D: Digital
- ⑩ Version “B”
- ⑪ Special Code #:Fit in with ROHS directive regulations

This product is composed of a TFT LCD panel, driver ICs, FPC, Control Board and a backlight unit. The following table described the features of SCA04330-BFN-LNC.

Item	Dimension	Unit
Dot Matrix	480 x RGBx 272(TFT)	dots
Module dimension	105.5x 67.2 x 4.7 (max)	mm
View area	95.04x 53.856	mm
Dot pitch	0.198 x 0.198	mm
Driving IC package	COG	
LCD type	TFT, Negative, Transmissive	
View direction	6 o'clock	
Backlight Type	LED, Normally White	
Controller IC	SSD1963	

*Expose the IC number blaze (Luminosity over than 1 cd) when using the LCM may cause IC operating failure.

*Color tone slight changed by temperature and driving voltage.

2. Block Diagram

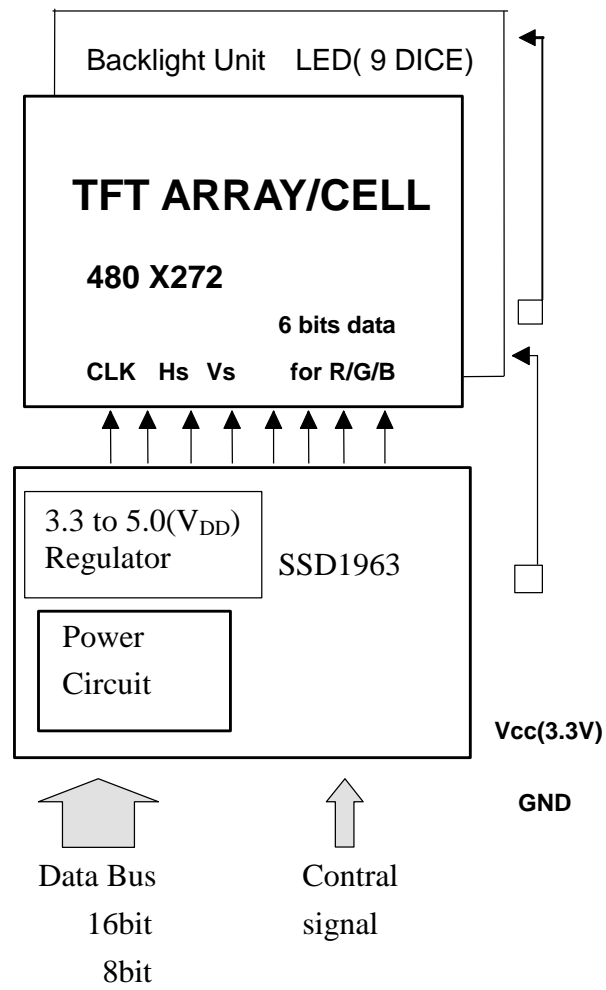

3. Electrical Characteristics

Item	Symbol	Values			Unit	Remark
		Min	TYP	max		
Operating voltage	VDD	3.0	3.3	3.6	V	
Input high voltage	VIH	0.8*VDD	-	VDD	V	
Input low voltage	VIL	0	-	0.2*VDD	V	
Output high voltage	VOH	VDD-0.3		VDD	V	
Output low voltage	VOL	0	-	0.3	V	
Current Consumption	IVCI	-	285	-	mA	
Power Consumption	PLCD	-	940.5	-	mW	

4. Absolute Maximum Ratings

Item	Symbol	Min	Typ	Max	Unit
Operating Temperature	T _{OP}	-20	-	+70	°C
Storage Temperature	T _{ST}	-30	-	+80	°C
Power Supply Voltage	VGH-VGL	-0.3		+45	V _{SS} =0
	VCC	-0.3	-	6.0	V

5.Interface Pin Function

5-1 Pins Connection To Control Board

P/N	Symbol	8 B IT Function
1	GND	Ground
2	VCC	Power supply for Logic
3	B\L Enable	Backlight control
4	RS	Command/Data select
5	WR	8080 family MPU interface : Write signal
6	RD	8080 family MPU interface: Read signal
7	DB0	Data bus
8	DB1	
9	DB2	
10	DB3	
11	DB4	
12	DB5	
13	DB6	
14	DB7	
15	CS	Chip select
16	RES	REST
17	NC	No connection
18	NC	No connection
19	DISP ON	Display on
20	NC	No connection

6. DC CHARACTERISTICS

Conditions:

Voltage referenced to VSS

VDDD, VDDPLL = 1.2V

VDDIO, VDDLCD = 3.3V

TA = 25°C

DC Characteristics

Symbol	Parameter	Test Condition	Min	Typ	Max	Unit
PSTY	Quiescent Power			300		uW
IIZ	Input leakage current		-1		1	uA
IOZ	Output leakage current		-1		1	uA
VOH	Output high voltage		0.8VDDIO			V
VOL	Output low voltage				0.2VDDIO	V
VIH	Input high voltage		0.8VDDIO		VDDIO + 0.5	V
VIL	Input low voltage				0.2VDDIO	V

7. AC Characteristics

Conditions:

Voltage referenced to V_{SS}

V_{DD}, V_{DDPLL} = 1.2V

V_{DDIO}, V_{DDLCD} = 3.3V

T_A = 25°C

C_L = 50pF (Bus/CPU Interface)

C_L = 0pF (LCD Panel Interface)

7.1 Clock Timing

Clock Input Requirements for CLK (PLL-bypass)

Symbol	Parameter	Min	Max	Units
FCLK	Input Clock Frequency (CLK)		120	MHz
TCLK	Input Clock period (CLK)	1/fCLK		ns

Clock Input Requirements for CLK (Using PLL)

Symbol	Parameter	Min	Max	Units
FCLK	Input Clock Frequency (CLK)	2.5	50	MHz
TCLK	Input Clock period (CLK)	1/fCLK		ns

Clock Input Requirements for crystal oscillator XTAL (Using PLL)

Symbol	Parameter	Min	Max	Units
FXTAL	Input Clock Frequency	2.5	10	MHz
TXTAL	Input Clock period	1/fXTAL		ns

7.2 MCU Interface Timing

7.2.1 6800 Mode

Table 7-4: 6800 Mode Timing

Symbol	Parameter	Min	Typ	Max	Unit
tcyc	Reference Clock Cycle Time	9	-	-	ns
tPWCSL	Pulse width CS# or E low	1	-	-	tCYC
tPWCSH	Pulse width CS# or E high	1	-	-	tCYC
tFDRD	First Data Read Delay	5	-	-	tCYC
tAS	Address Setup Time	1	-	-	ns
tAH	Address Hold Time	1	-	-	ns
tDSW	Data Setup Time	4	-	-	ns
tDHW	Data Hold Time	1	-	-	ns
tDSR	Data Access Time	-	-	5	ns
tDHR	Output Hold time	1	-	-	ns

Figure 7-1: 6800 Mode Timing Diagram (Use CS# as Clock)

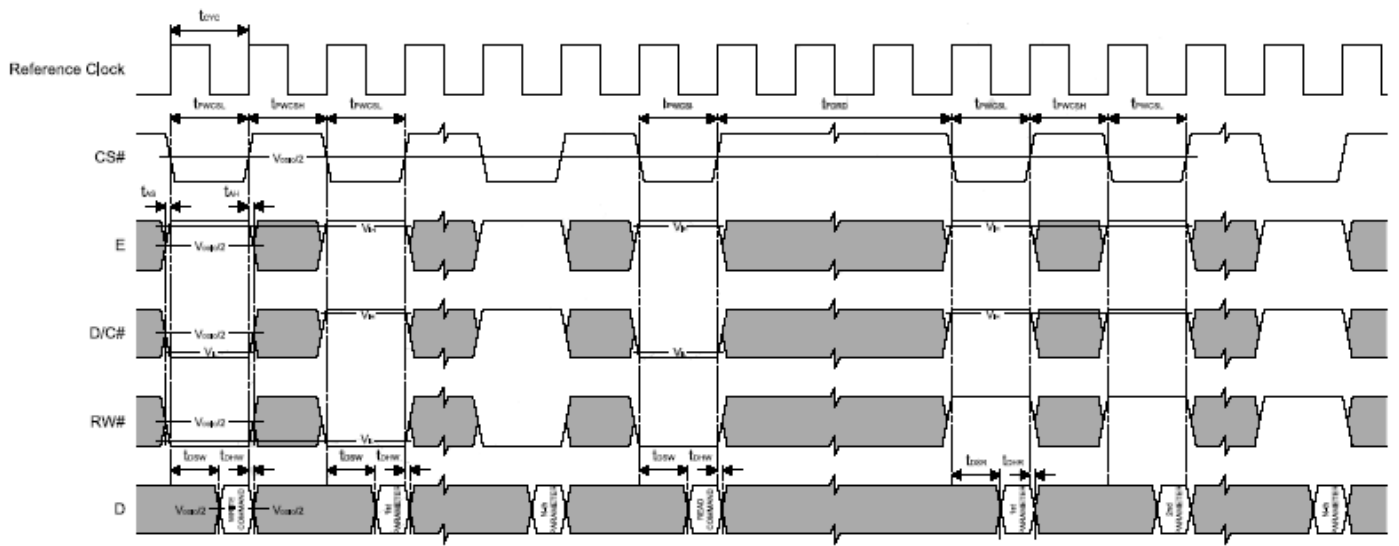
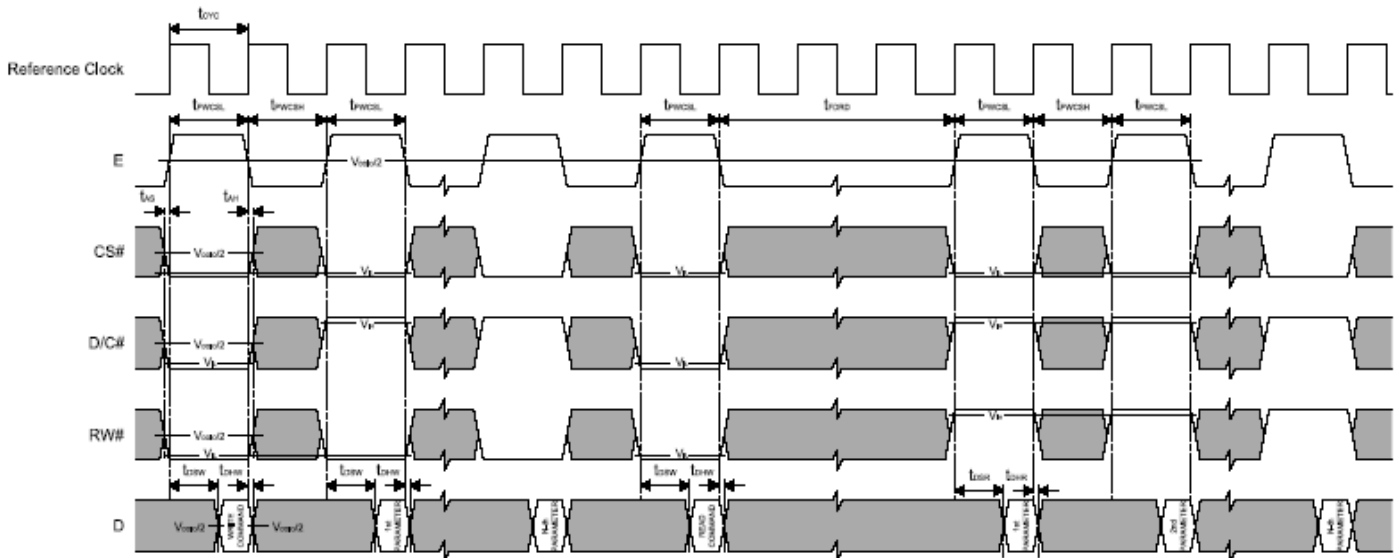

Figure 7-2: 6800 Mode Timing Diagram (Use E as Clock)



7.2.2 8080 Mode Write Cycle

Table 7-5: 8080 Mode Timing

Symbol	Parameter	Min	Typ	Max	Unit
t _{cy}	Reference Clock Cycle Time	9	-	-	ns
t _{PWCSL}	Pulse width CS# low	1	-	-	t _{CYC}
t _{PWCSH}	Pulse width CS# high	1	-	-	t _{CYC}
t _{FDRD}	First Read Data Delay	5	-	-	t _{CYC}
t _{AS}	Address Setup Time	1	-	-	ns
t _{AH}	Address Hold Time	1	-	-	ns
t _{DSW}	Data Setup Time	4	-	-	ns
t _{DHW}	Data Hold Time	1	-	-	ns
t _{DSR}	Data Access Time	-	-	5	ns
t _{DHR}	Output Hold time	1	-	-	ns

Figure 7-3: 8080 Mode Timing Diagram

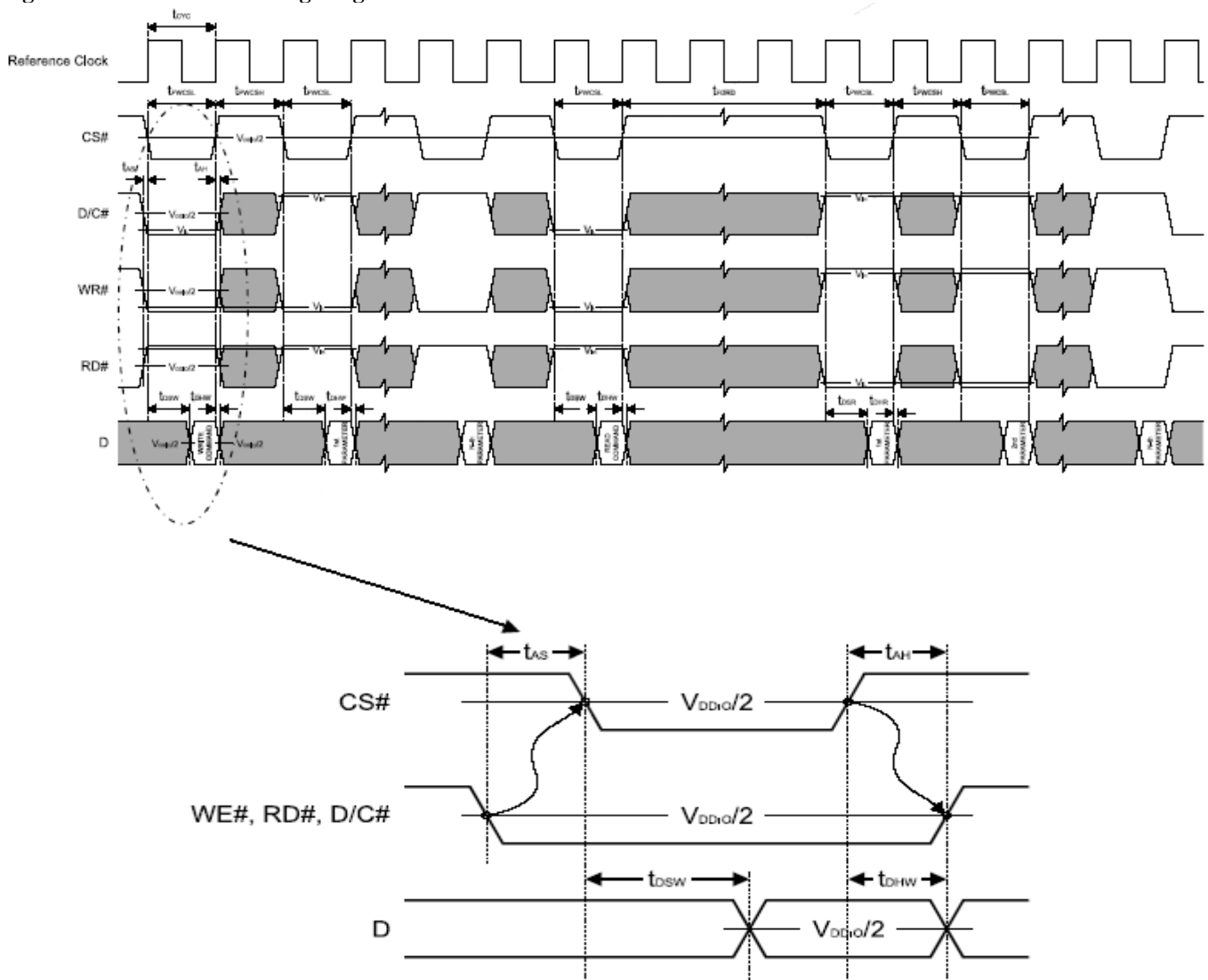

8. Data transfer order Setting

Pixel Data Format

Both 6800 and 8080 support 8-bit, 9-bit, 16-bit, 18-bit and 24-bit data bus. Depending on the width of the data bus, the display data are packed into the data bus in different ways.

Pixel Data Format :

Interface	Cycle	D[23]	D[22]	D[21]	D[20]	D[19]	D[18]	D[17]	D[16]	D[15]	D[14]	D[13]	D[12]	D[11]	D[10]	D[9]	D[8]	D[7]	D[6]	D[5]	D[4]	D[3]	D[2]	D[1]	D[0]			
24 bits	1 st	R7	R6	R5	R4	R3	R2	R1	R0	G7	G6	G5	G4	G3	G2	G1	G0	B7	B6	B5	B4	B3	B2	B1	B0			
18 bits	1 st								R5	R4	R3	R2	R1	R0	G5	G4	G3	G2	G1	G0	B5	B4	B3	B2	B1	B0		
16 bits (565 format)	1 st									R5	R4	R3	R2	R1	G5	G4	G3	G2	G1	G0	B5	B4	B3	B2	B1			
16 bits	1 st									R5	R4	R3	R2	R1	R0	X	X	G5	G4	G3	G2	G1	G0	X	X			
	2 nd																	B5	B4	B3	B2	B1	B0	X	X			
	3 rd																	G5	G4	G3	G2	G1	G0	X	X			
9 bits	1 st																	R5	R4	R3	R2	R1	R0	G5	G4	G3		
	2 nd																	G2	G1	G0	B5	B4	B3	B2	B1	B0		
8 bits	1 st																				R5	R4	R3	R2	R1	R0	X	X
	2 nd																				G5	G4	G3	G2	G1	G0	X	X
	3 rd																				B5	B4	B3	B2	B1	B0	X	X

X: Don't Care

9 Register Depiction

Please consult the spec of SSD1963

10. OPTICAL CHARACTERISTIC

The following items are measured under stable conditions. The optical characteristics should be measured in a dark room or equivalent with the methods shown in Note.1.

7.1 Main LCD Optical Characteristics

Item		Symbol	Condition	Min	TYP	max	Unit	Remark
Viewing Angle	Top	FH	CR ≥ 10	-	50	-	degree	Note.2
	Bottom	FL		-	55	-		
	Left	TL		-	60	-		
	Right	TR		-	60	-		
Response time (Tr+Tf)			T=0		50	-	ms	Note.3
Brightness			Center	350	400		Cm/m ²	
Contrast Ratio		CR	At optimized Viewing angle	200	250	-	-	Note.4
Color chromaticity	White	Xw	Viewing normal angle F,T=0	0.258	0.308	0.358	-	Note.5
		Yw		0.278	0.328	0.378		
	Red	XR		0.558	0.608	0.658	-	
		YR		0.307	0.357	0.407	-	
	Green	XG		0.279	0.329	0.379	-	-
		YG		0.533	0.583	0.633	-	
	Blue	XB		0.093	0.143	0.193	-	-
		YB		0.050	0.100	0.150	-	-

Note.1: After stabilizing and leaving the panel alone at a given temperature for 30 minutes, the measurement should be executed. Measurement should be executed in a stable, windless, and dark room. Optical specifications are measured by Topcon BM-7(fast) with a viewing angle of 1° at a distance of 50 cm and normal direction.

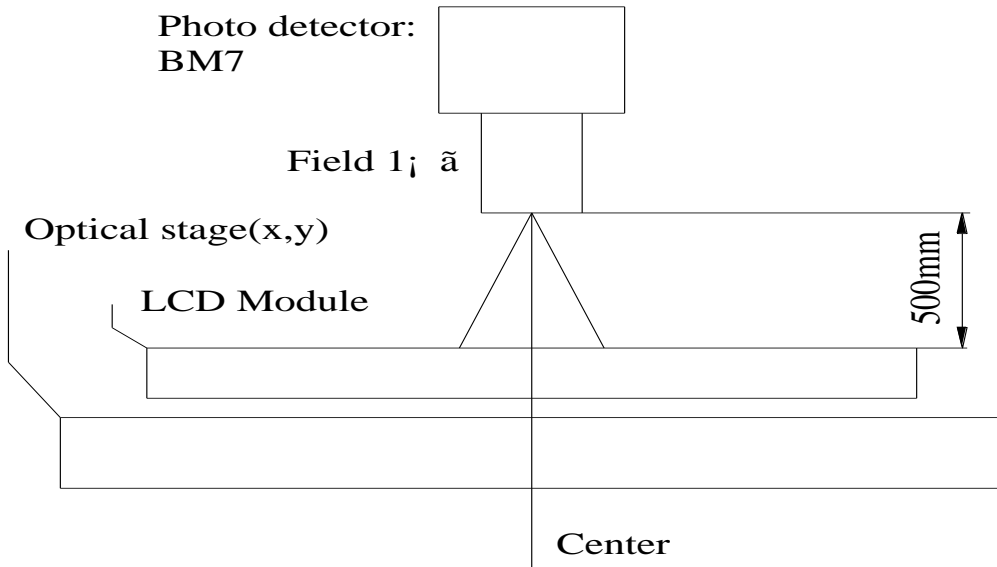

Not.2: Definition of Viewing Angle: Refer to figure as below:

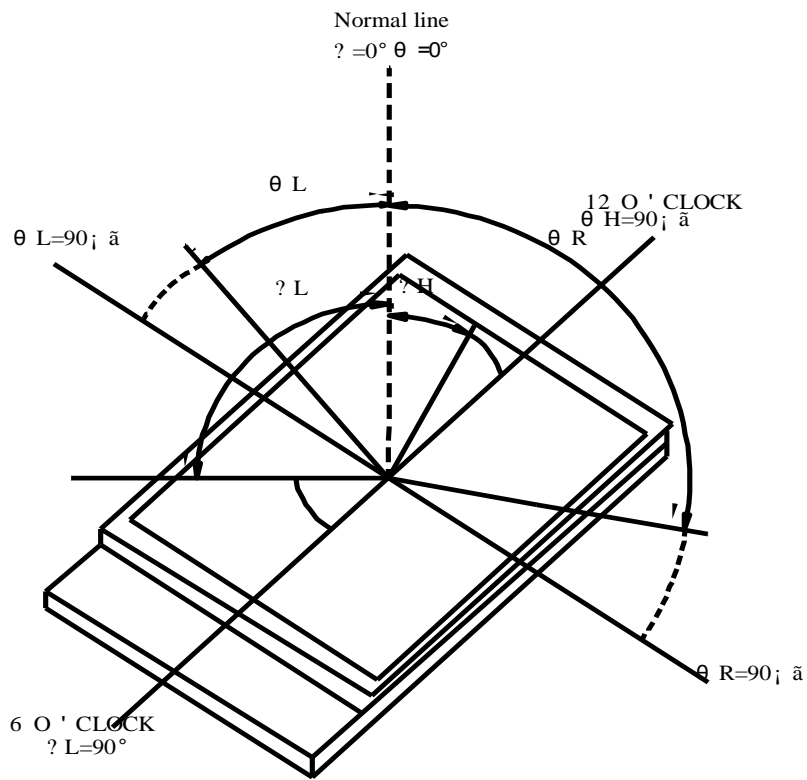

Not.3: Definition of Response Time: TR and TF

The figure below is the output signal of the photo detector.

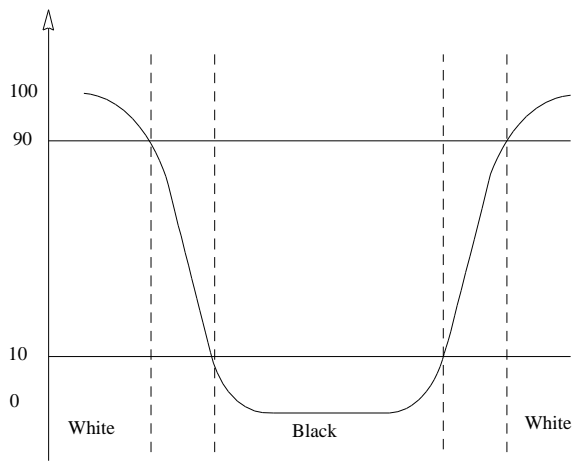

Not4: Definition of Contrast Ratio(CR)

Ratio of gray max (G max)& gray min(G min)

(G max)=luminance with all pixel white

(G min)= luminance with all pixel black

Not5: Measured at the center area of the panel when all the input terminals of LCD panel are electrically opened.

11. Contour Drawing

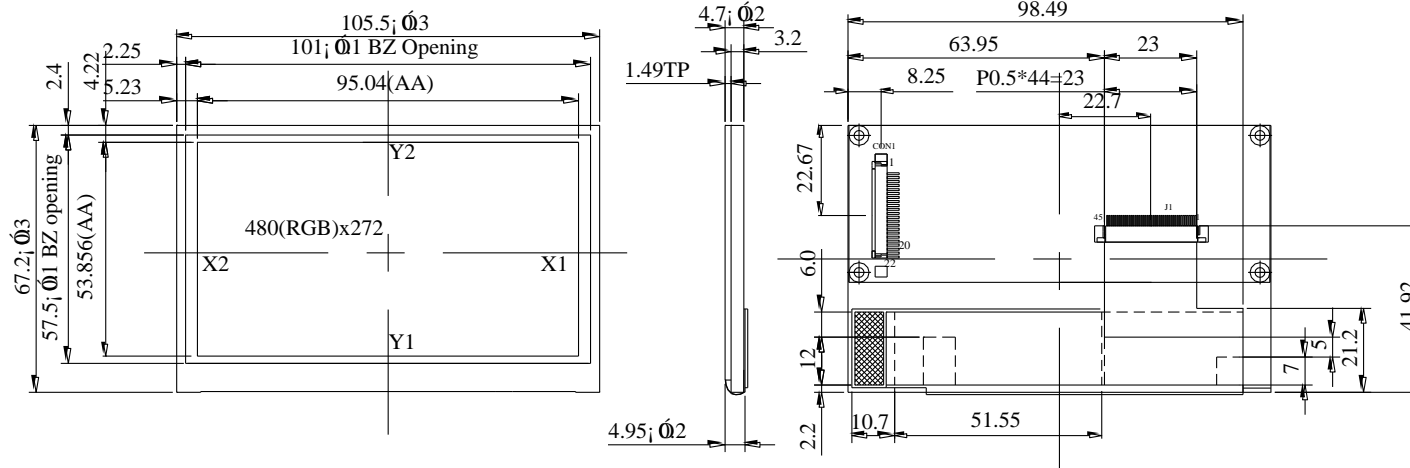

PIN	ASSIGNMENT
1	GND
2	VDD
3	B/L Enable
4	RS
5	WR
6	RD
7	DB0
8	DB1
9	DB2
10	DB3
11	DB4
12	DB5
13	DB6
14	DB7
15	CS
16	RES
17	NC
18	NC
19	DISP_ON
20	NC

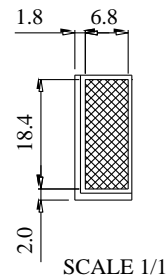
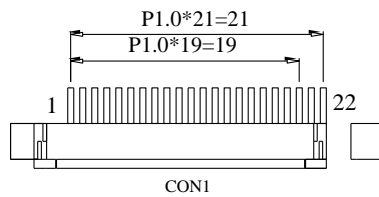

The non-specified tolerance of dimension is $\pm 0.2\text{mm}$.

12. LED driving conditions

Backlight Unit (VSS=0v)

Item	Symbol	Values			Unit	Remark
		Min	TYP	max		
LED Voltage	VL	-	25	-	V	
LED Current	IF	-	20	-	MA	
Power Consumption	PLED	-	500	-	MW	

LED Forward Current

Forward Current Derating Curve

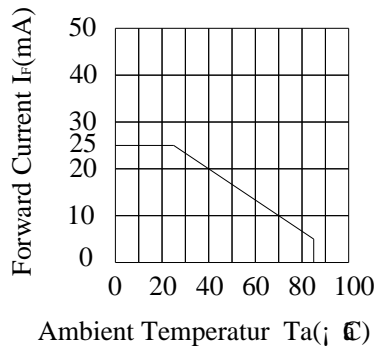

13. Inspection specification

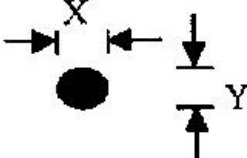
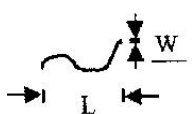
NO	Item	Criterion	AQL													
01	Electrical Testing	1.1 Missing vertical, horizontal segment, segment contrast defect. 1.2 Missing character, dot or icon. 1.3 Display malfunction. 1.4 No function or no display. 1.5 Current consumption exceeds product specifications. 1.6 LCD viewing angle defect. 1.7 Mixed product types. 1.8 Contrast defect.	0.65													
02	Black or white spots on LCD (display only)	2.1 White and black spots on display $\leq 0.25\text{mm}$, no more than three white or black spots present. 2.2 Densely spaced: No more than two spots or lines within 3mm	2.5													
03	LCD black spots, white spots, contamination (non-display)	3.1 Round type : As following drawing $\Phi = (x + y) / 2$  <table border="1" data-bbox="869 873 1348 1377"> <thead> <tr> <th>SIZE</th> <th>Acceptable Q TY</th> </tr> </thead> <tbody> <tr> <td>$\Phi \leq 0.10$</td> <td>Accept no dense</td> </tr> <tr> <td>$0.10 < \Phi \leq 0.20$</td> <td>2</td> </tr> <tr> <td>$0.20 < \Phi \leq 0.25$</td> <td>1</td> </tr> <tr> <td>$0.25 < \Phi$</td> <td>0</td> </tr> </tbody> </table>	SIZE	Acceptable Q TY	$\Phi \leq 0.10$	Accept no dense	$0.10 < \Phi \leq 0.20$	2	$0.20 < \Phi \leq 0.25$	1	$0.25 < \Phi$	0	2.5			
		SIZE	Acceptable Q TY													
$\Phi \leq 0.10$	Accept no dense															
$0.10 < \Phi \leq 0.20$	2															
$0.20 < \Phi \leq 0.25$	1															
$0.25 < \Phi$	0															
3.2 Line type : (As following drawing)  <table border="1" data-bbox="710 1422 1348 1691"> <thead> <tr> <th>Length</th> <th>Width</th> <th>Acceptable Q TY</th> </tr> </thead> <tbody> <tr> <td>---</td> <td>$W \leq 0.02$</td> <td>Accept no dense</td> </tr> <tr> <td>$L \leq 3.0$</td> <td>$0.02 < W \leq 0.03$</td> <td rowspan="2">2</td> </tr> <tr> <td>$L \leq 2.5$</td> <td>$0.03 < W \leq 0.05$</td> </tr> <tr> <td>---</td> <td>$0.05 < W$</td> <td>As round type</td> </tr> </tbody> </table>	Length	Width	Acceptable Q TY	---	$W \leq 0.02$	Accept no dense	$L \leq 3.0$	$0.02 < W \leq 0.03$	2	$L \leq 2.5$	$0.03 < W \leq 0.05$	---	$0.05 < W$	As round type		
Length	Width	Acceptable Q TY														
---	$W \leq 0.02$	Accept no dense														
$L \leq 3.0$	$0.02 < W \leq 0.03$	2														
$L \leq 2.5$	$0.03 < W \leq 0.05$															
---	$0.05 < W$	As round type														
04	Polarizer bubbles	If bubbles are visible, judge using black spot specifications, not easy to find, must check in specify direction.	<table border="1" data-bbox="837 1724 1348 2049"> <thead> <tr> <th>Size Φ</th> <th>Acceptable Q TY</th> </tr> </thead> <tbody> <tr> <td>$\Phi \leq 0.20$</td> <td>Accept no dense</td> </tr> <tr> <td>$0.20 < \Phi \leq 0.50$</td> <td>3</td> </tr> <tr> <td>$0.50 < \Phi \leq 1.00$</td> <td>2</td> </tr> <tr> <td>$1.00 < \Phi$</td> <td>0</td> </tr> <tr> <td>Total Q TY</td> <td>3</td> </tr> </tbody> </table>	Size Φ	Acceptable Q TY	$\Phi \leq 0.20$	Accept no dense	$0.20 < \Phi \leq 0.50$	3	$0.50 < \Phi \leq 1.00$	2	$1.00 < \Phi$	0	Total Q TY	3	2.5
Size Φ	Acceptable Q TY															
$\Phi \leq 0.20$	Accept no dense															
$0.20 < \Phi \leq 0.50$	3															
$0.50 < \Phi \leq 1.00$	2															
$1.00 < \Phi$	0															
Total Q TY	3															

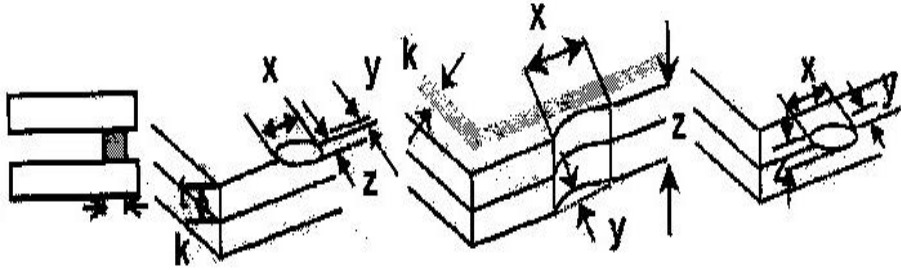
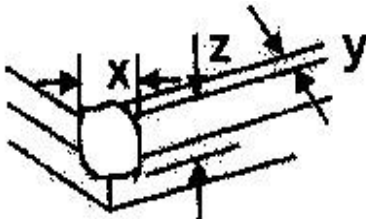
NO	Item	Criterion	AQL																		
05	Scratches	Follow NO.3 LCD black spots, white spots, contamination																			
06	Chipped glass	<p>Symbols Define: x: Chip length y: Chip width z: Chip thickness k: Seal width t: Glass thickness a: LCD side length L: Electrode pad length:</p> <p>6.1 General glass chip : 6.1.1 Chip on panel surface and crack between panels:</p>  <table border="1" data-bbox="443 831 1353 1055"> <thead> <tr> <th>z: Chip thickness</th> <th>y: Chip width</th> <th>x: Chip length</th> </tr> </thead> <tbody> <tr> <td>$Z \leq 1/2t$</td> <td>Not over viewing area</td> <td>$x \leq 1/8a$</td> </tr> <tr> <td>$1/2t < z \leq 2t$</td> <td>Not exceed 1/3k</td> <td>$x \leq 1/8a$</td> </tr> </tbody> </table> <p>⊙ If there are 2 or more chips, x is total length of each chip.</p> <p>6.1.2 Corner crack:</p>  <table border="1" data-bbox="443 1507 1353 1731"> <thead> <tr> <th>z: Chip thickness</th> <th>y: Chip width</th> <th>x: Chip length</th> </tr> </thead> <tbody> <tr> <td>$Z \leq 1/2t$</td> <td>Not over viewing area</td> <td>$x \leq 1/8a$</td> </tr> <tr> <td>$1/2t < z \leq 2t$</td> <td>Not exceed 1/3k</td> <td>$x \leq 1/8a$</td> </tr> </tbody> </table> <p>⊙ If there are 2 or more chips, x is the total length of each chip.</p>	z: Chip thickness	y: Chip width	x: Chip length	$Z \leq 1/2t$	Not over viewing area	$x \leq 1/8a$	$1/2t < z \leq 2t$	Not exceed 1/3k	$x \leq 1/8a$	z: Chip thickness	y: Chip width	x: Chip length	$Z \leq 1/2t$	Not over viewing area	$x \leq 1/8a$	$1/2t < z \leq 2t$	Not exceed 1/3k	$x \leq 1/8a$	2.5
z: Chip thickness	y: Chip width	x: Chip length																			
$Z \leq 1/2t$	Not over viewing area	$x \leq 1/8a$																			
$1/2t < z \leq 2t$	Not exceed 1/3k	$x \leq 1/8a$																			
z: Chip thickness	y: Chip width	x: Chip length																			
$Z \leq 1/2t$	Not over viewing area	$x \leq 1/8a$																			
$1/2t < z \leq 2t$	Not exceed 1/3k	$x \leq 1/8a$																			

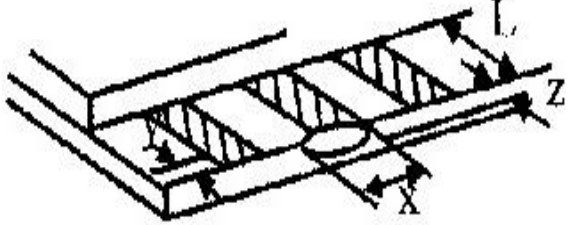
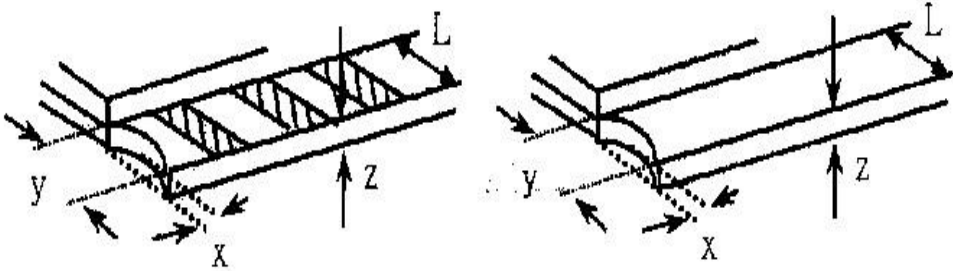
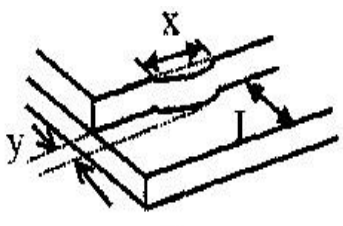
NO	Item	Criterion	AQL								
06	Glass crack	<p>Symbols :</p> <p>x: Chip length y: Chip width z: Chip thickness k: Seal width t: Glass thickness a: LCD side length L: Electrode pad length</p> <p>6.2 Protrusion over terminal :</p> <p>6.2.1 Chip on electrode pad :</p> 	2.5								
		<table border="1"> <tr> <td data-bbox="352 705 655 763">y: Chip width</td> <td data-bbox="655 705 959 763">x: Chip length</td> <td data-bbox="959 705 1262 763">z: Chip thickness</td> </tr> <tr> <td data-bbox="352 763 655 824">$y \leq 0.5\text{mm}$</td> <td data-bbox="655 763 959 824">$x \leq 1/8a$</td> <td data-bbox="959 763 1262 824">$0 < z \leq t$</td> </tr> </table>		y: Chip width	x: Chip length	z: Chip thickness	$y \leq 0.5\text{mm}$	$x \leq 1/8a$	$0 < z \leq t$		
		y: Chip width		x: Chip length	z: Chip thickness						
		$y \leq 0.5\text{mm}$		$x \leq 1/8a$	$0 < z \leq t$						
<p>6.2.2 Non-conductive portion:</p> 											
<table border="1"> <tr> <td data-bbox="427 1167 715 1279">y: Chip width</td> <td data-bbox="715 1167 1002 1279">x: Chip length</td> <td data-bbox="1002 1167 1262 1279">z: Chip thickness</td> </tr> <tr> <td data-bbox="427 1279 715 1339">$y \leq L$</td> <td data-bbox="715 1279 1002 1339">$x \leq 1/8a$</td> <td data-bbox="1002 1279 1262 1339">$0 < z \leq t$</td> </tr> </table> <p>⊙ If the chipped area touches the ITO terminal, over 2/3 of the ITO must remain and be inspected according to electrode terminal specifications.</p> <p>⊙ If the product will be heat sealed by the customer, the alignment mark not be damaged.</p> <p>6.2.3 Substrate protuberance and internal crack.</p>  <table border="1"> <tr> <td data-bbox="762 1686 1018 1744">y: width</td> <td data-bbox="1018 1686 1268 1744">x: length</td> </tr> <tr> <td data-bbox="762 1744 1018 1803">$y \leq 1/3L$</td> <td data-bbox="1018 1744 1268 1803">$x \leq a$</td> </tr> </table>	y: Chip width	x: Chip length	z: Chip thickness	$y \leq L$	$x \leq 1/8a$	$0 < z \leq t$	y: width	x: length	$y \leq 1/3L$	$x \leq a$	
y: Chip width	x: Chip length	z: Chip thickness									
$y \leq L$	$x \leq 1/8a$	$0 < z \leq t$									
y: width	x: length										
$y \leq 1/3L$	$x \leq a$										

NO	Item	Criterion	AQL
07	Cracked glass	The LCD with extensive crack is not acceptable.	2.5
08	Backlight elements	8.1 Illumination source flickers when lit. 8.2 Spots or scratched that appear when lit must be judged. Using LCD spot, lines and contamination standards. 8.3 Backlight doesn't light or color wrong.	0.65 2.5 0.65
09	Bezel	9.1 Bezel may not have rust, be deformed or have fingerprints, stains or other contamination. 9.2 Bezel must comply with job specifications.	2.5 0.65
10	PCB, COB	10.1 COB seal may not have pinholes larger than 0.2mm or contamination. 10.2 COB seal surface may not have pinholes through to the IC. 10.3 The height of the COB should not exceed the height indicated in the assembly diagram. 10.4 There may not be more than 2mm of sealant outside the seal area on the PCB. And there should be no more than three places. 10.5 No oxidation or contamination PCB terminals. 10.6 Parts on PCB must be the same as on the production characteristic chart. There should be no wrong parts, missing parts or excess parts. 10.7 The jumper on the PCB should conform to the product characteristic chart. 10.8 If solder gets on bezel tab pads, LED pad, zebra pad or screw hold pad, make sure it is smoothed down.	2.5 2.5 0.65 2.5 2.5 0.65 2.5
11	Soldering	11.1 No un-melted solder paste may be present on the PCB. 11.2 No cold solder joints, missing solder connections, oxidation or icicle. 11.3 No residue or solder balls on PCB. 11.4 No short circuits in components on PCB.	2.5 2.5 2.5 0.65

--	--	--	--

NO	Item	Criterion	AQL
12	General appearance	12.1 No oxidation, contamination, curves or, bends on interface Pin (OLB) of TCP.	2.5
		12.2 No cracks on interface pin (OLB) of TCP.	0.65
		12.3 No contamination, solder residue or solder balls on product.	2.5
		12.4 The IC on the TCP may not be damaged, circuits.	2.5
		12.5 The uppermost edge of the protective strip on the interface pin must be present or look as if it cause the interface pin to sever.	2.5
		12.6 The residual rosin or tin oil of soldering (component or chip component) is not burned into brown or black color.	0.65
		12.7 Sealant on top of the ITO circuit has not hardened.	0.65
		12.8 Pin type must match type in specification sheet.	0.65
		12.9 LCD pin loose or missing pins.	0.65
		12.10 Product packaging must the same as specified on packaging specification sheet.	0.65
		12.11 Product dimension and structure must conform to product specification sheet.	0.65



INNOVATIVE DISPLAY TECHNOLOGIES

17171 MURPHY AVENUE

IRVINE, CALIFORNIA 92614-5915

P: 949-417-8070/F: 949-417-8075

SCA04330-BFN-LNC

Sales signature : _____

Customer Signature : _____

Date : / / _____