

# Application Note AN-1074

## A new Circuit for Low-Cost Electronic Ballast Passive Valley Fill with additional Control Circuits for Low Total Harmonic Distortion and Low Crest Factor

By Cecilia Contenti, Peter Green and Tom Ribarich

### Table of Contents

	<b>Page</b>
Passive Valley Fill Test Results .....	1
Passive Valley Fill Test Results with 36W/T8 ballast section PIN =36.5W,VAC = 230V, load: 36W/T8 .....	4
Passive Valley Fill Test Results with 36W/T8 ballast section PIN =36.5W,VAC = 230V, load: 36W/T8 and additional circuit to modulate the frequency .....	11
Passive Valley Fill Test Results with 58W/T8 ballast section PIN =63W,VAC = 230V, load: 58W/T8 .....	20

The goal of this design is to implement a low-cost linear ballast with good PFC, acceptable THD and low current-crest factor. The ballast will use Passive Valley Fill configuration to reduce costs compared to standard PFC. To overcome the disadvantage of the very high current crest factor, additional circuit has been used to modulate the Half Bridge frequency versus the bus voltage. The system will work at a minimum frequency when the bus voltage is low and increase the frequency while the bus voltage increases. This will stabilize the lamp power versus the AC line changes, improve the current crest factor and improve EMI because the operating frequency varies in a frequency range. The solution has been implemented for 2 different lamps: 36W and 58W T8.

## A new Circuit for Low-Cost Electronic Ballast Passive Valley Fill with additional Control Circuits for Low Total Harmonic Distortion and Low Crest Factor

by  
 Cecilia Contenti, Peter Green & Tom Ribarich

### Abstract:

The goal of this design is to implement a low-cost linear ballast with good PFC, acceptable THD and low current-crest factor.

The ballast will use Passive Valley Fill configuration to reduce costs compared to standard PFC. To overcome the disadvantage of the very high current crest factor, additional circuit has been used to modulate the Half Bridge frequency versus the bus voltage. The system will work at a minimum frequency when the bus voltage is low and increase the frequency while the bus voltage increases. This will stabilize the lamp power versus the AC line changes, improve the current crest factor and improve EMI because the operating frequency varies in a frequency range. The solution has been implemented for 2 different lamps: 36W and 58W T8.

### Passive Valley Fill Test Results

Schematics tested:

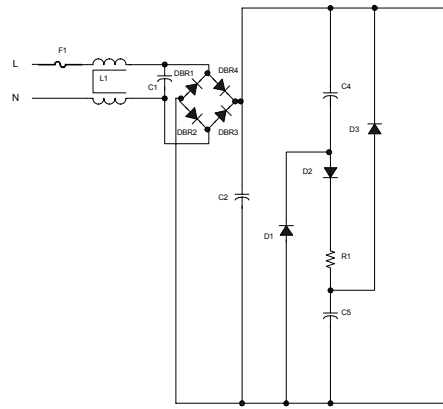
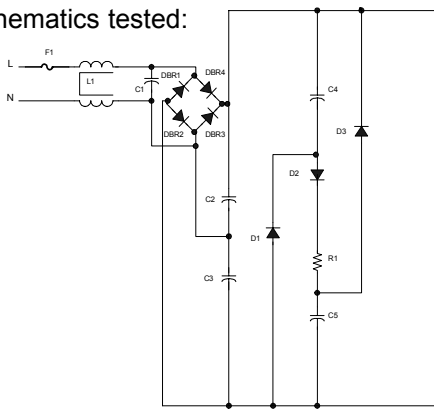

These circuits produced the same result. Test with resistive load (1.5K) to provide 36W load at 230VAC in.

DBR1, DBR2, DBR3, DBR4, D1, D2, D3: 10DF6 diode

C1 = 0.33uF, 275VAC

L1 = 1X10mH 0.7Apk, Common mode EMI inductor

C2, C3 (fig. 1) = 100nF, 275V, C2 (fig. 2) = 100nF, 400V

C4, C5 = 47uF

R1 effects:

Higher R1, lower harmonics but lower minimum bus Voltage. The best trade-off is 1.2K: the harmonics are within the Class C limits of EN61000-3-2, the PF is 0.964 and the minimum bus is 110V

<b>Harmonics</b>	<b>Results</b>	<b>Class C Limits</b>
<b>AH2</b>	0	<b>2</b>
<b>AH3</b>	10.8	<b>30</b>
<b>AH5</b>	9.9	<b>10</b>
<b>AH7</b>	4.4	<b>7</b>
<b>AH9</b>	2.5	<b>5</b>
<b>AH11</b>	2.2	<b>3</b>
<b>AH13</b>	2.9	<b>3</b>
<b>AH15</b>	2	<b>3</b>
<b>AH17</b>	0.4	<b>3</b>
<b>AH19</b>	0.8	<b>3</b>
<b>AH21</b>	1.1	<b>3</b>
<b>AH23</b>	1.4	<b>3</b>
<b>AH25</b>	0.8	<b>3</b>
<b>AH27</b>	1.3	<b>3</b>
<b>AH29</b>	0.7	<b>3</b>
<b>AH31</b>	0.3	<b>3</b>
<b>AH33</b>	0.9	<b>3</b>
<b>AH35</b>	1.2	<b>3</b>
<b>AH37</b>	2	<b>3</b>
<b>AH39</b>	1.5	<b>3</b>

With a lower value of R1, the harmonics are above the limits. For example, with 1K we have AH13 = 3.3.

Figure 1 shows the bus voltage and input current in this situation ( $R1=1.2K$ ,  $VAC = 230V$ ,  $PIN = 36W$ ,  $Rload = 1.5K$ ).

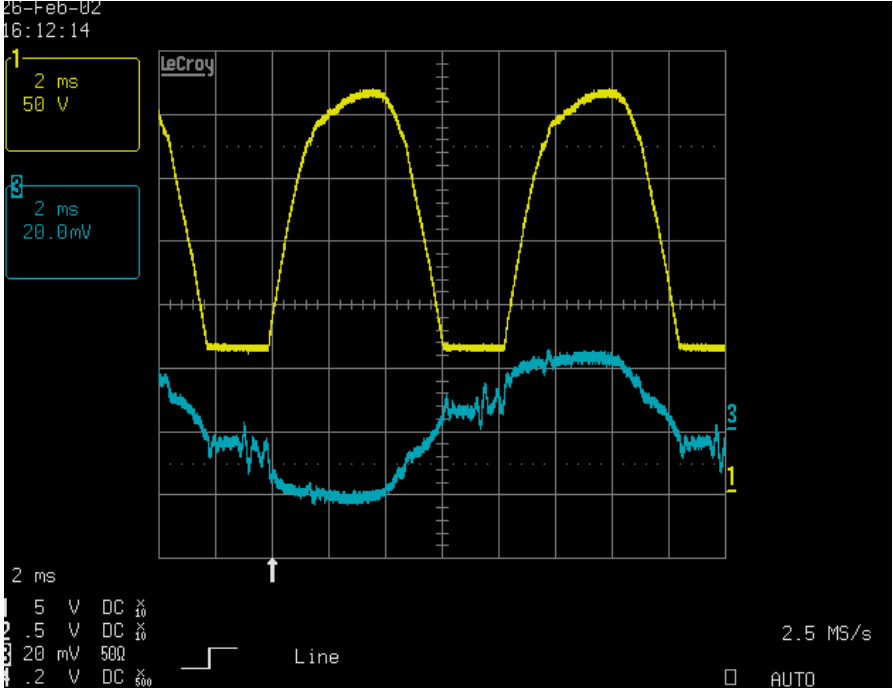

**Figure 1: Bus voltage and input current with  $R1=1.2K$ ,  $VAC = 230V$ ,  $PIN = 36W$ ,  $Rload = 1.5K$ .**

**Passive Valley Fill Test Results with 36W/T8 ballast section PIN =36.5W,  
 VAC = 230V, load: 36W/T8**

Figure 2 shows the circuit with fixed frequency.

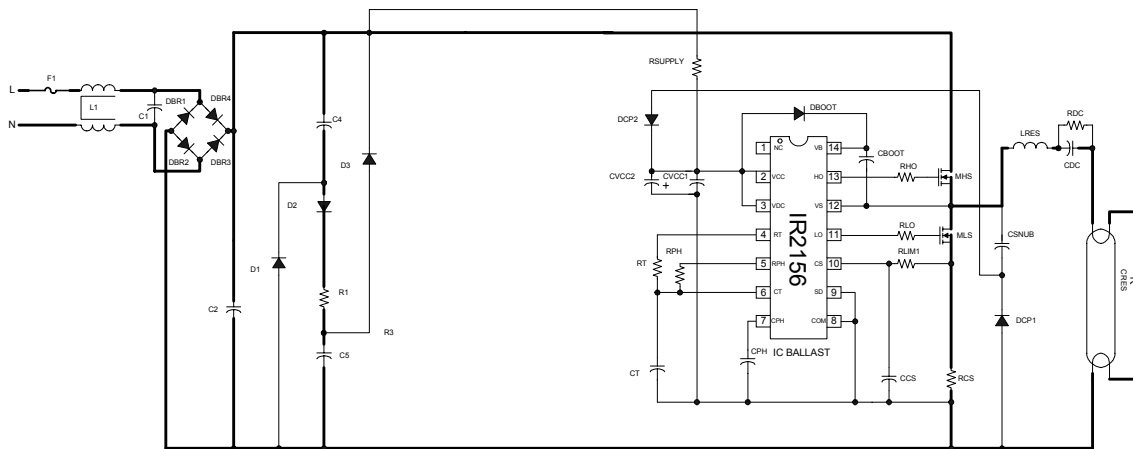

Note: Thick traces represent high-frequency, high-current paths. Lead lengths should be minimized to avoid high-frequency noise problems

**Figure 2: Passive Valley Fill circuit with fixed frequency.**

Results with fixed frequency, R1= 1.2K: PF = 0.938

<b>Harmonics</b>	<b>Results</b>	<b>Class C Limits</b>
<b>AH2</b>	0	<b>2</b>
<b>AH3</b>	6.8	<b>30</b>
<b>AH5</b>	11.7	<b>10</b>
<b>AH7</b>	12.1	<b>7</b>
<b>AH9</b>	8.8	<b>5</b>
<b>AH11</b>	1.7	<b>3</b>
<b>AH13</b>	6.3	<b>3</b>
<b>AH15</b>	5.8	<b>3</b>
<b>AH17</b>	2.4	<b>3</b>
<b>AH19</b>	1.1	<b>3</b>
<b>AH21</b>	1.9	<b>3</b>
<b>AH23</b>	2.5	<b>3</b>
<b>AH25</b>	2.5	<b>3</b>
<b>AH27</b>	0.8	<b>3</b>
<b>AH29</b>	2.3	<b>3</b>
<b>AH31</b>	1.7	<b>3</b>
<b>AH33</b>	1.4	<b>3</b>
<b>AH35</b>	2	<b>3</b>
<b>AH37</b>	4.1	<b>3</b>
<b>AH39</b>	2.9	<b>3</b>

Figure 3 shows the bus voltage, the lamp voltage and lamp current in this situation (R1=1.2K).

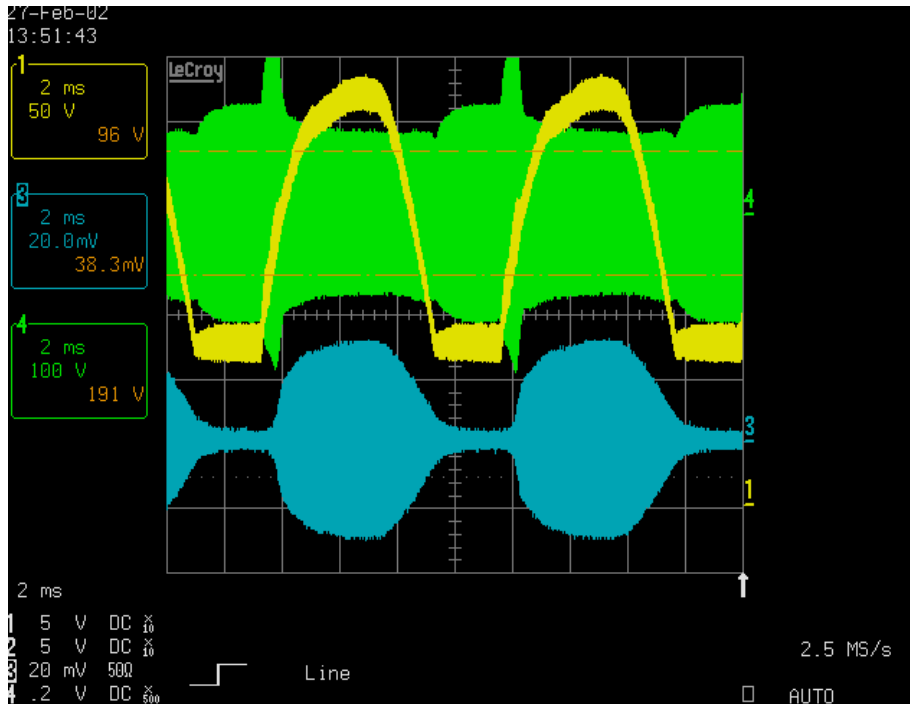
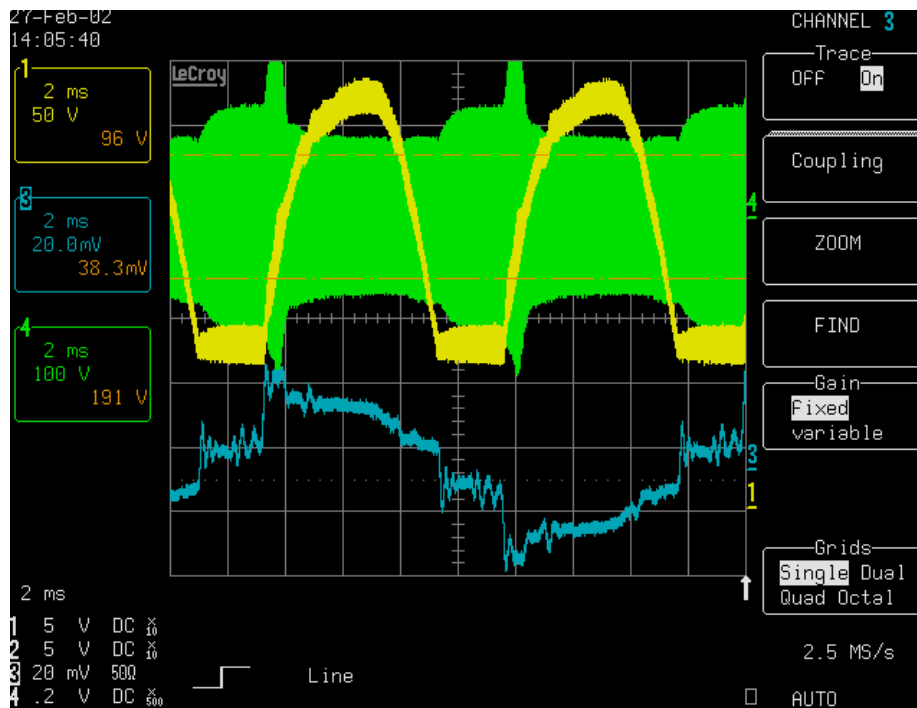

Figure 3: Bus voltage (yellow), lamp voltage (green) and lamp current (blue) with R1=1.2K and fixed frequency.

As you can see, the lamp current goes too low when the bus voltage goes to the minimum. The lamp re-strikes every half cycle.

Figure 4 shows the bus voltage, the lamp voltage and the input current in this situation ( $R1=1.2K$ )



**Figure 4. Bus voltage (yellow), the lamp voltage (green) and the input current (blue) with  $R1 = 1.2K$  and fixed frequency.**

As you can see, we have a peak in the lamp current that we do not have with a resistive load, this has as a result high harmonic distortion.

To solve the problem of the multiple ignitions of the lamp, we needed to increase the minimum bus reducing the value of  $R1$  to 200 Ohm.



## AN-1074

Results Fixed frequency, R1= 200ohm: PF = 0.938

<b>Harmonics</b>	<b>Results</b>	<b>Class C Limits</b>
<b>AH2</b>	0	<b>2</b>
<b>AH3</b>	7.8	<b>30</b>
<b>AH5</b>	11.4	<b>10</b>
<b>AH7</b>	14.2	<b>7</b>
<b>AH9</b>	4.9	<b>5</b>
<b>AH11</b>	8.7	<b>3</b>
<b>AH13</b>	7.5	<b>3</b>
<b>AH15</b>	2.5	<b>3</b>
<b>AH17</b>	2.6	<b>3</b>
<b>AH19</b>	4.3	<b>3</b>
<b>AH21</b>	1.9	<b>3</b>
<b>AH23</b>	2.3	<b>3</b>
<b>AH25</b>	3	<b>3</b>
<b>AH27</b>	2.9	<b>3</b>
<b>AH29</b>	0.7	<b>3</b>
<b>AH31</b>	3.4	<b>3</b>
<b>AH33</b>	3.1	<b>3</b>
<b>AH35</b>	0.5	<b>3</b>
<b>AH37</b>	1.8	<b>3</b>
<b>AH39</b>	1.8	<b>3</b>

Figure 5 shows the bus voltage (yellow), the lamp voltage (green) and lamp current (blue) in this situation (R1= 200 Ohm).

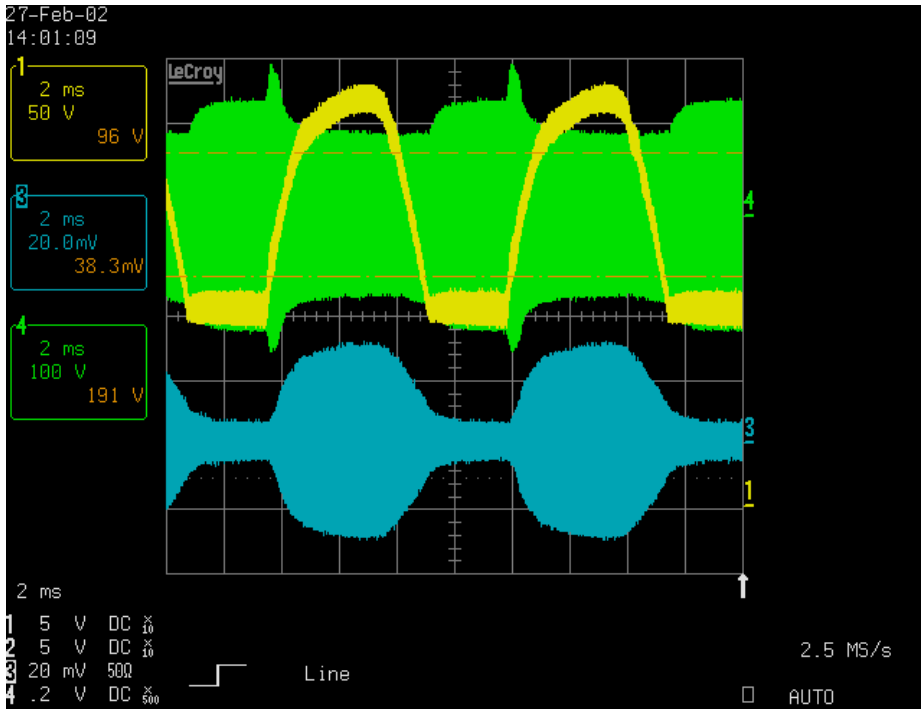

**Figure 5: bus voltage (yellow), lamp voltage (green) and lamp current (blue) with R1= 200 Ohm.**

As you can see, the lamp current varies too much also with a minimum bus of 160V.

Figure 6 shows the bus voltage, the lamp voltage and the input current in this situation ( $R_1=200$  Ohm).

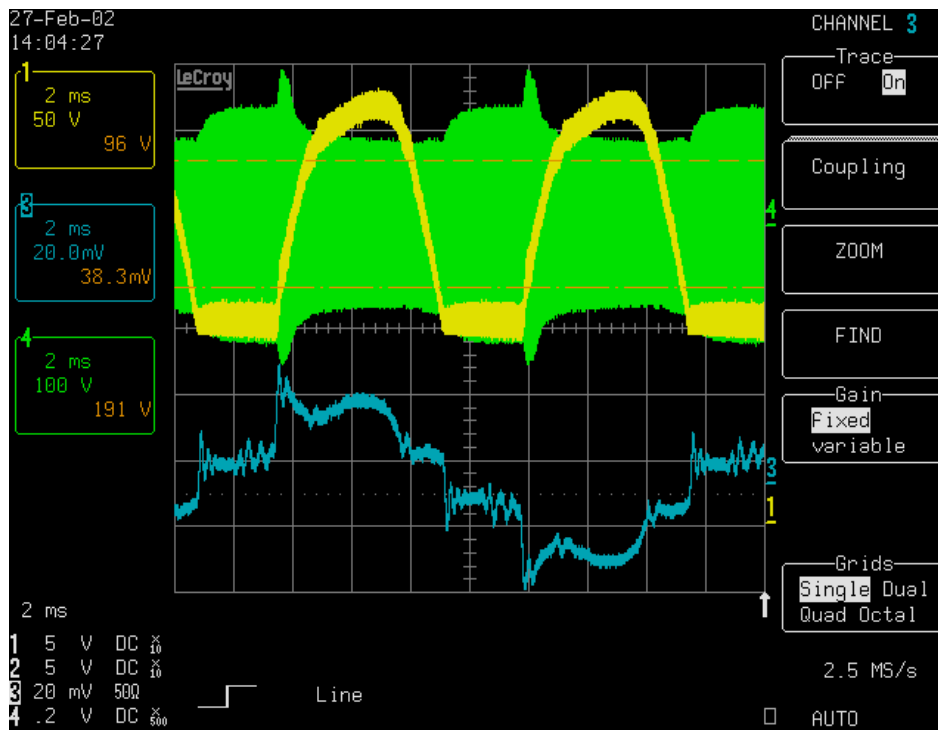

**Figure 6: bus voltage (yellow), lamp voltage (green) and input current (blue) with  $R_1=200$  Ohm.**

As you can see, the peak in the input current does not improve, causing very high harmonics.

To improve the crest factor and reduce the variation of the lamp current during the line voltage half cycle, we have added a circuit, which modulates the working frequency of the ballast according on the bus voltage.

The ballast is tuned to work at the minimum bus voltage at a fixed frequency ( $f_{min}$ ). When the bus voltage increases, the frequency is also increased to compensate by reducing the lamp current and hence keeping the lamp power as constant as possible.

**Passive Valley Fill Test Results with 36W/T8 ballast section PIN =36.5W,  
 VAC = 230V, load: 36W/T8 and additional circuit to modulate the frequency.**

Figure 7 shows the circuit with frequency modulation.

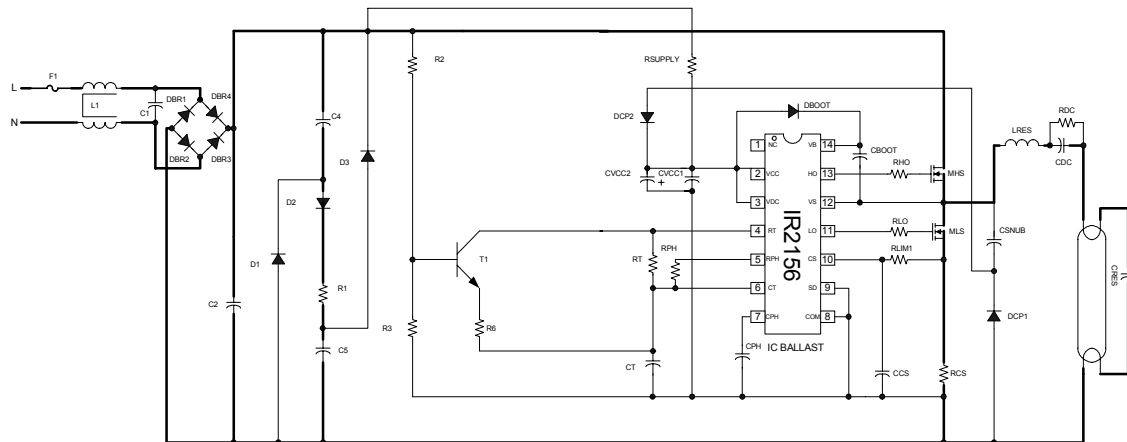

**Note:** Thick traces represent high-frequency, high-current paths. Lead lengths should be minimized to avoid high-frequency noise problems

**Figure 7: Passive Valley Fill circuit with frequency modulation.**

The amount of modulation (frequency range) can be adjusted by varying R6. The collector of T1 is connected to RT, so that it has not effect on the dead-time. The dead-time is constant when the frequency changes, avoiding hard-switching.

**Results with frequency modulation, R1= 1.2K: PF = 0.915**

<b>Harmonics</b>	<b>Results</b>	<b>Class C Limits</b>
<b>AH2</b>	0	<b>2</b>
<b>AH3</b>	16.5	<b>30</b>
<b>AH5</b>	9.5	<b>10</b>
<b>AH7</b>	13.5	<b>7</b>
<b>AH9</b>	13.8	<b>5</b>
<b>AH11</b>	5.7	<b>3</b>
<b>AH13</b>	4.1	<b>3</b>
<b>AH15</b>	8.1	<b>3</b>
<b>AH17</b>	7.7	<b>3</b>
<b>AH19</b>	4.3	<b>3</b>
<b>AH21</b>	2.8	<b>3</b>
<b>AH23</b>	5.1	<b>3</b>
<b>AH25</b>	5.3	<b>3</b>
<b>AH27</b>	1.4	<b>3</b>
<b>AH29</b>	2	<b>3</b>
<b>AH31</b>	2.2	<b>3</b>
<b>AH33</b>	2.9	<b>3</b>
<b>AH35</b>	0.6	<b>3</b>
<b>AH37</b>	2.9	<b>3</b>
<b>AH39</b>	2.8	<b>3</b>

Figure 8 shows the bus voltage, the lamp voltage and lamp current in this situation (R1=1.2K and frequency modulation).

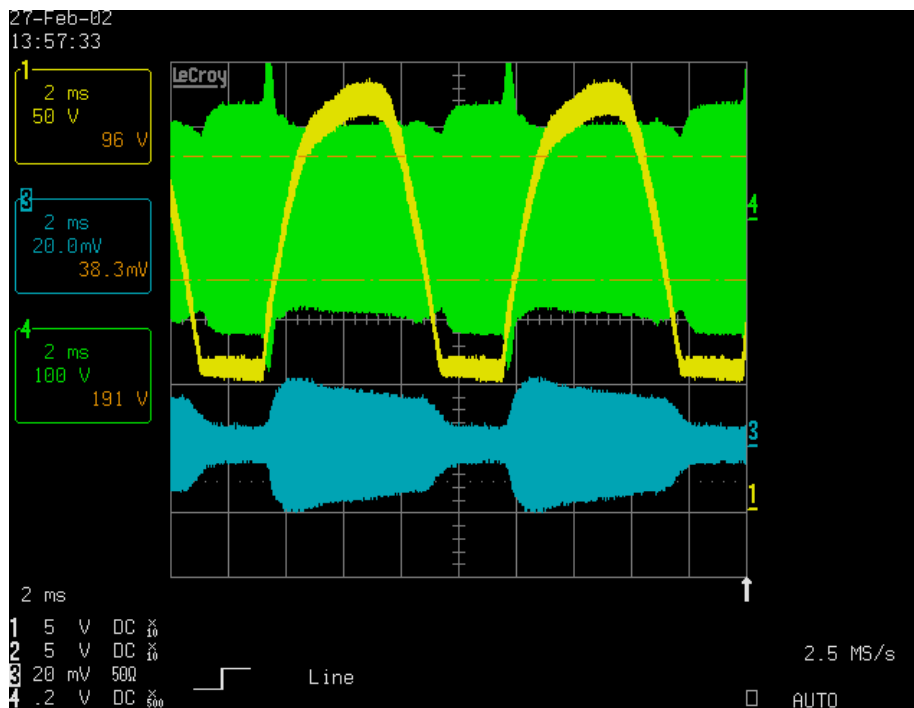

**Figure 8: bus voltage (yellow), lamp voltage (green) and lamp current (blue) with R1=1.2K and frequency modulation.**

As you can see, even with frequency modulation, the lamp current still goes too low when the bus voltage goes to the minimum (110V). The lamp partially re-strikes every half cycle.

Figure 9 shows the bus voltage, the lamp voltage and the input current in this situation ( $R1=1.2K$  and frequency modulation).

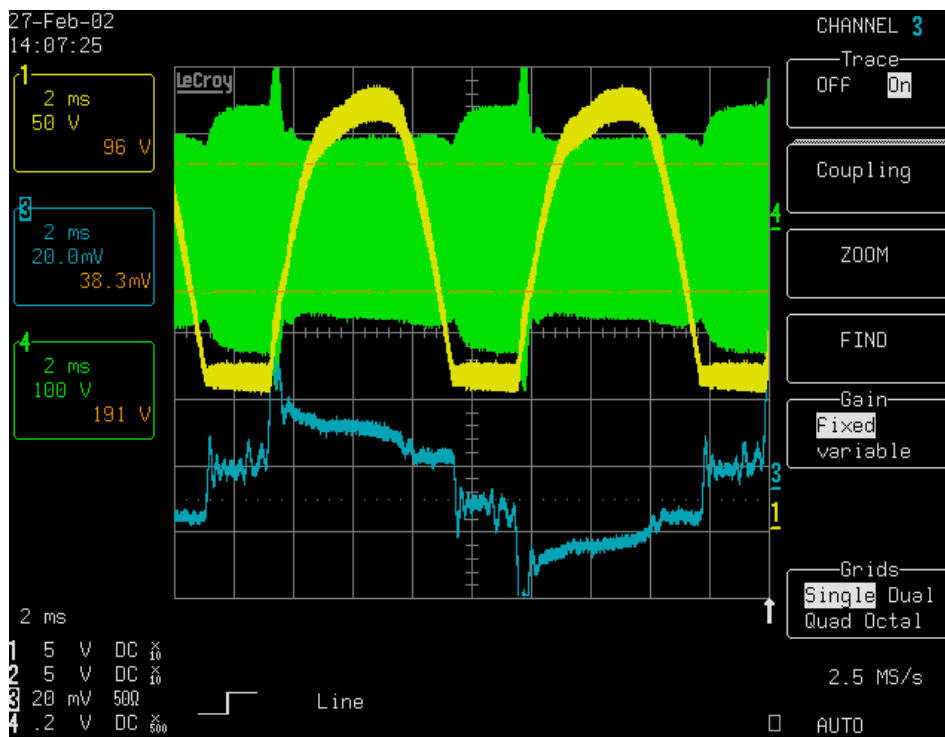

**Figure 9: bus voltage (yellow), lamp voltage (green) and input current (blue) with  $R1=1.2K$  and frequency modulation.**

As you can see, we cannot solve the problem of the current going too low with the frequency modulation. We needed to increase the minimum bus by reducing the value of  $R1$  to 200 Ohm.

Results with frequency modulation, R1= 200ohm: PF = 0.938

<b>Harmonics</b>	<b>Results</b>	<b>Class C Limits</b>
<b>AH2</b>	0	<b>2</b>
<b>AH3</b>	5	<b>30</b>
<b>AH5</b>	9.9	<b>10</b>
<b>AH7</b>	16.1	<b>7</b>
<b>AH9</b>	8.2	<b>5</b>
<b>AH11</b>	8.4	<b>3</b>
<b>AH13</b>	10	<b>3</b>
<b>AH15</b>	3.9	<b>3</b>
<b>AH17</b>	3.4	<b>3</b>
<b>AH19</b>	5.7	<b>3</b>
<b>AH21</b>	3.9	<b>3</b>
<b>AH23</b>	1.7	<b>3</b>
<b>AH25</b>	4.5	<b>3</b>
<b>AH27</b>	3.9	<b>3</b>
<b>AH29</b>	1.6	<b>3</b>
<b>AH31</b>	4.8	<b>3</b>
<b>AH33</b>	4.2	<b>3</b>
<b>AH35</b>	1	<b>3</b>
<b>AH37</b>	2.1	<b>3</b>
<b>AH39</b>	2.0	<b>3</b>



Figure 10 shows the bus voltage, the lamp voltage and the lamp current in this situation (R1= 200 Ohm and frequency modulation)

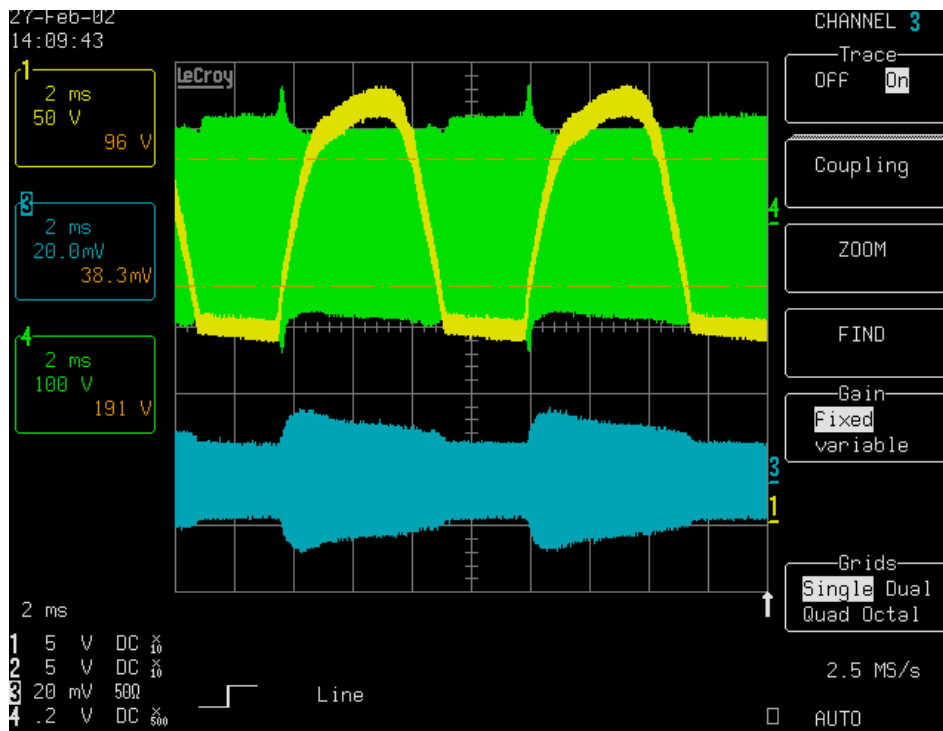

**Figure 10: bus voltage (yellow), lamp voltage (green) and lamp current (blue) with R1= 200 Ohm and frequency modulation.**

As you can see, with frequency modulation and minimum bus of 160V, the lamp current does not vary too much.

Figure 11 shows the bus voltage, the lamp voltage and the input current in this situation (R1=200 Ohm and frequency modulation)

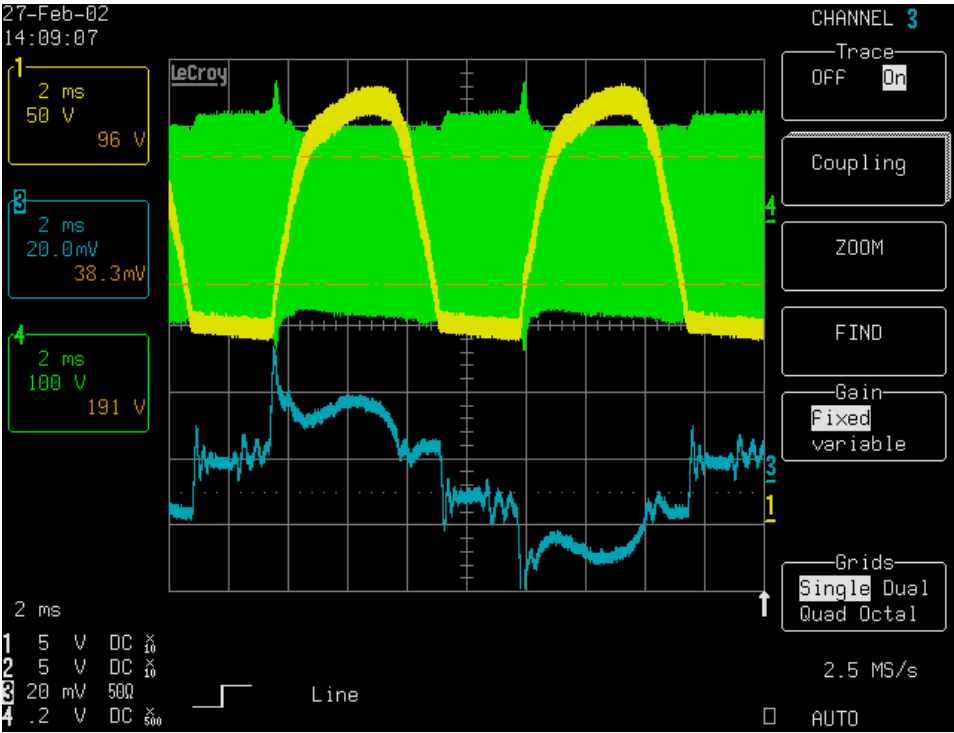

**Figure 11: bus voltage (yellow), amp voltage (green) and input current (blue) with R1=200 Ohm and frequency modulation.**

As you can see, the peak in the input current does not improve and the harmonics are still too high.

Figure 12 shows the frequencies at the minimum of the bus and at the maximum

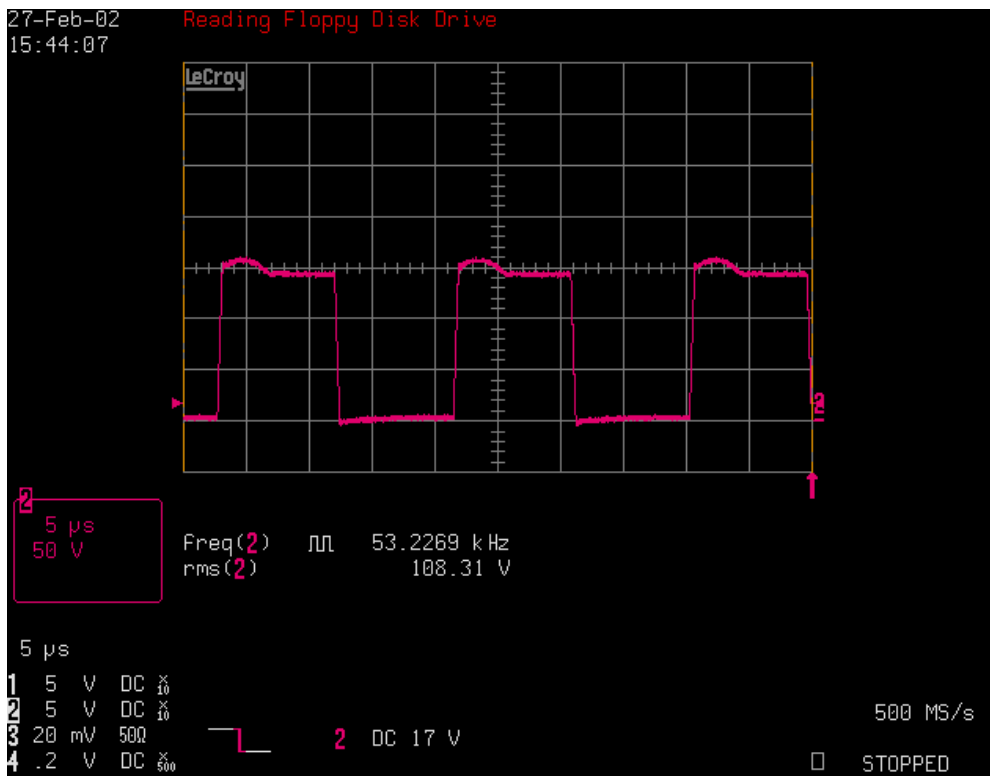

**VBUS = 150V, frequency 53KHz**

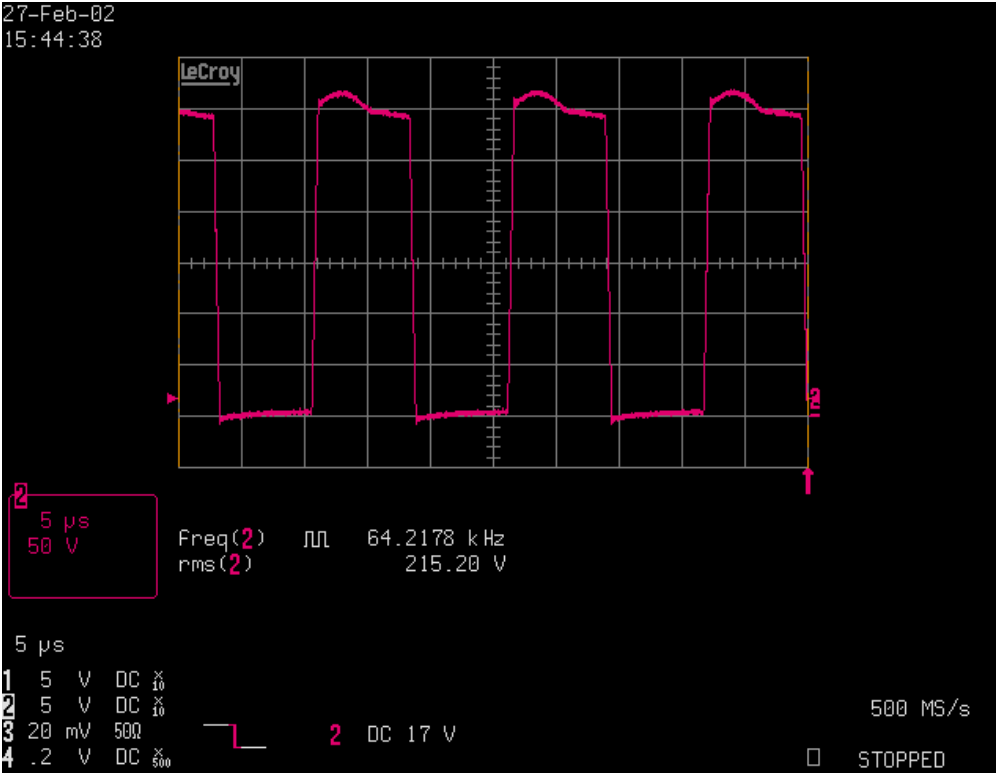

**VBUS = 320V, frequency 64KHz**

**Figure 12: VS pin and frequencies at the minimum of the bus and at the maximum.**

**Passive Valley Fill Test Results with 58W/T8 ballast section PIN =63W,  
VAC = 230V, load: 58W/T8**

Frequency modulation, R1= 100 Ohm: PF = 0.943

<b>Harmonics</b>	<b>Results</b>	<b>Class C Limits</b>
<b>AH2</b>	0	<b>2</b>
<b>AH3</b>	7.8	<b>30</b>
<b>AH5</b>	9.2	<b>10</b>
<b>AH7</b>	18.9	<b>7</b>
<b>AH9</b>	9	<b>5</b>
<b>AH11</b>	9.2	<b>3</b>
<b>AH13</b>	10	<b>3</b>
<b>AH15</b>	4.1	<b>3</b>
<b>AH17</b>	3	<b>3</b>
<b>AH19</b>	6.7	<b>3</b>
<b>AH21</b>	5.8	<b>3</b>
<b>AH23</b>	3	<b>3</b>
<b>AH25</b>	5.6	<b>3</b>
<b>AH27</b>	4.4	<b>3</b>
<b>AH29</b>	2.2	<b>3</b>
<b>AH31</b>	4.3	<b>3</b>
<b>AH33</b>	4.4	<b>3</b>
<b>AH35</b>	1.3	<b>3</b>
<b>AH37</b>	3.3	<b>3</b>
<b>AH39</b>	3	<b>3</b>

Figure 13 shows the bus voltage, the lamp voltage and lamp current with  $R1 = 100 \text{ ohm}$  and frequency modulation.

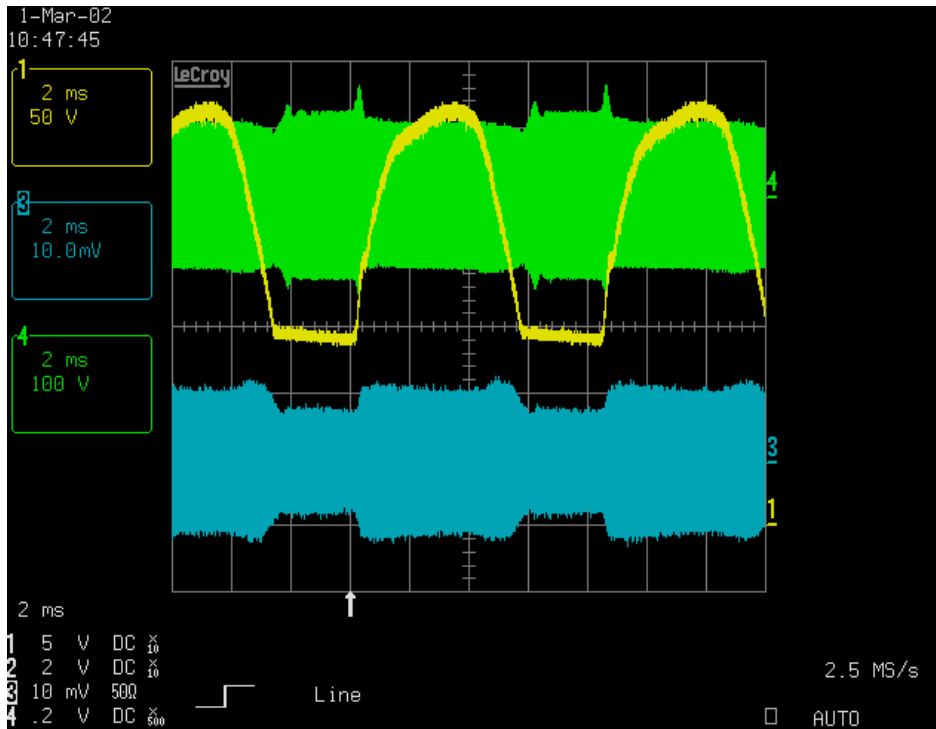

**Figure 13: bus voltage (yellow), lamp voltage (green) and lamp current (blue) with  $R1 = 100 \text{ ohm}$  and frequency modulation.**

The results are very similar to what we saw for the 36W/T8: the lamp current is reduced when the bus voltage goes to the minimum. The crest factor is acceptable.

Figure 14 shows the bus voltage, the lamp voltage and the input current with  $R1 = 100 \text{ ohm}$  and frequency modulation.

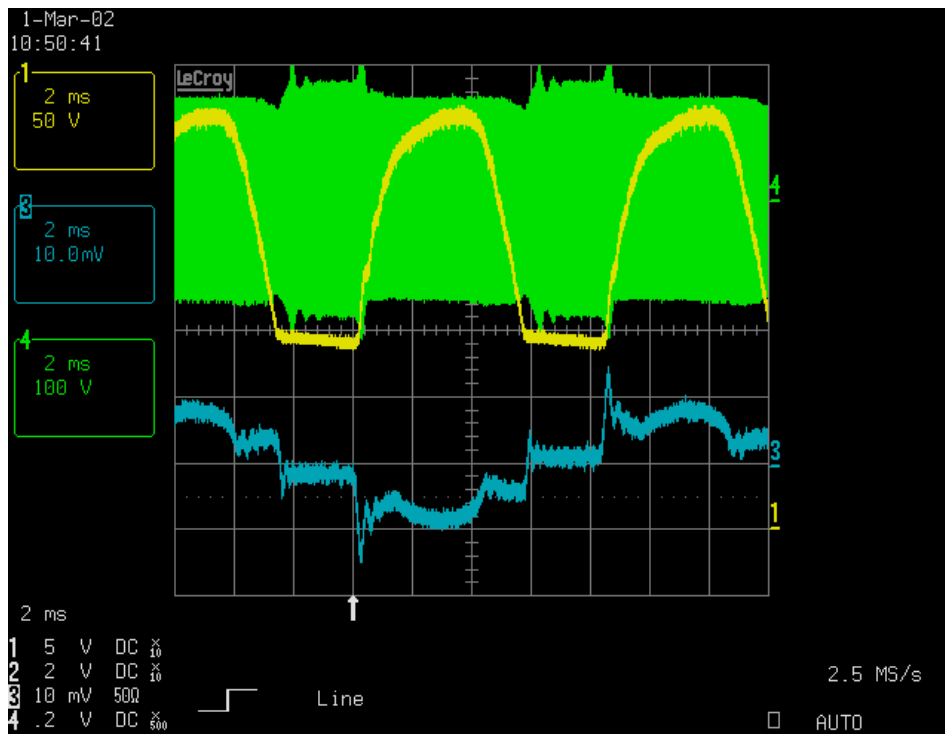

**Figure 14: bus voltage (yellow), lamp voltage (green) and input current (blue) with  $R1 = 100 \text{ ohm}$  and frequency modulation.**

The results are very similar to what we saw for the 36W/T8: we have the same peak in the lamp current, causing high harmonic distortion.

Figure 15 shows the frequencies at the minimum of the bus and at the maximum.

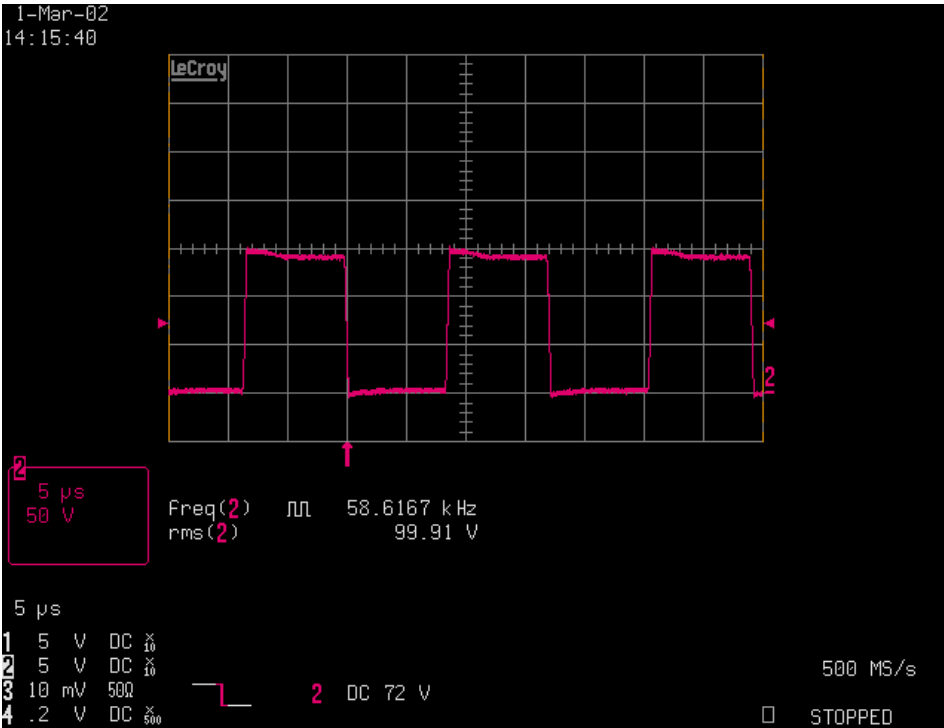

**VBUS = 150V, frequency 58.6 KHz**



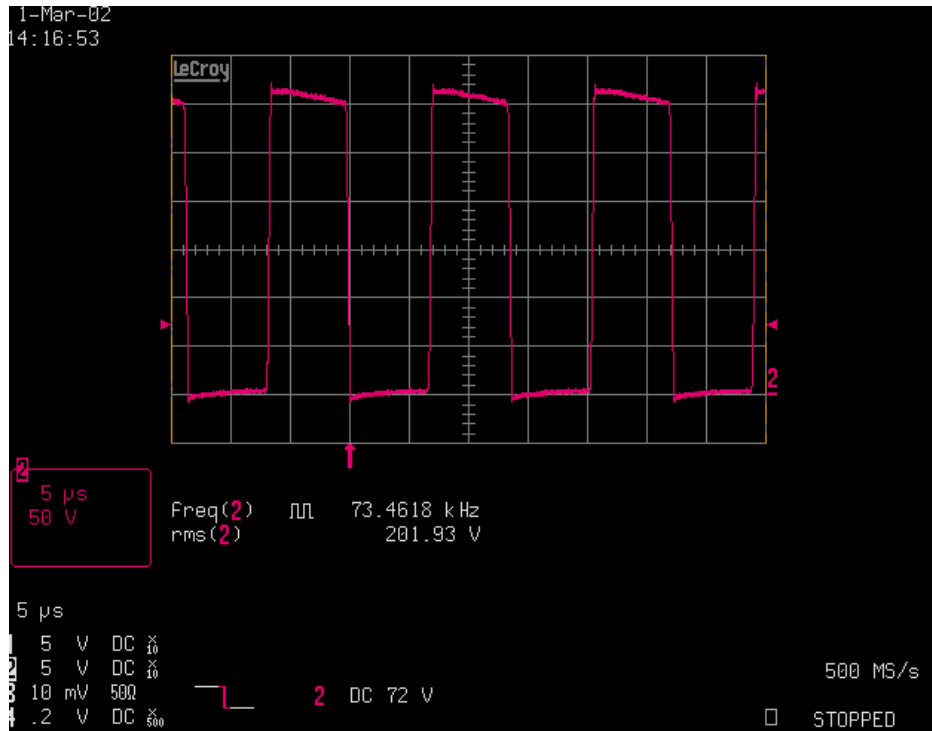

**VBUS = 320V, frequency 73.5 KHz**

**Figure 15: VS pin and frequencies at the minimum of the bus and at the maximum.**

**BOM 36W/T8, Passive Valley fill, 220/240 VAC**

Item #	Qt	Manufacturer	Part Number	Description	Reference
1	8		10DF6	Rectifier, 1A 600V	DBR1, DBR2, DBR3, DBR4, D1, D2, D3, DBOOT
2	1	Roederstein	F1772433-2200	Capacitor, 0.33uF, 275VAC	C1
3	1	Panasonic	ELF-15N007A	EMI Inductor, 1X10mH 0.7Apk	L1
4	1	WIMA	MKP10	Capacitor, 0.1uF, 400VDC	CDC
5	1	WIMA	MKP10	Capacitor, 0.22uF, 400VDC	C2
6	2			Capacitor, 47uF, 250V	C4, C5
7	1			Resistor, 42K	R6 <sup>1</sup>
8	1			Resistor, 430K	R2
9	1			Resistor, 20K	R3
10	1			Resistor, 200ohm, 1W	R1
11	1			Resistor, 1K ohm, SMT1206	RLIM1
12	2			Capacitor, 0.1uF SMT1206	CVCC1, CBOOT
13	1	Panasonic	ECE-A1HGE02R2	Capacitor, 2.2uF 50VDC	CVCC2
14	2	International Rectifier	IRF830	Transistor, MOSFET	MLS, MHS
15	2	Panasonic	ERJ-8GEYJ22	Resistor, 22 ohm SMT 1206	RLO, RHO
16	1		PN2222A	Transistor NPN	T1
17	1			Resistor, 28K Ohm	RT <sup>2</sup>
18	1			Resistor, 43K Ohm	RPH <sup>3</sup>
19	1			Capacitor, 560pF, SMT1206	CT
20	1			Capacitor, 0.47uF, SMT1206	CPH
21	1			Resistor, 0.43 Ohm 1/2W	RCS
22	1			Capacitor, 470pF SMT1206	CCS
23	1	Diodes	LL4148DICT-ND	Diode, 1N4148 SMT DL35	DCP2
24	1			18V Zener Diode	DCP1
25	1			Capacitor, 1.5nF 1.6KV, 1812	CSNUB
26	1			Capacitor, 15nF 1600V	CRES
27	1	International Rectifier	IR2156	IC, Ballast Driver w/PFC	IC BALLAST
28	1			Inductor, 0.8mH 3Apk	LRES
29	1			Resistor, 147K ohm	RSUPPLY
30	1			Resistor, 100K ohm	RDC
31	1			Fuse, 0.5 ohm, 1/2 W	F1
Total	42				

JCT, JRT are in  
 CY and RV1 not mounted

- <sup>1</sup> USE POT
- <sup>2</sup> USE POT
- <sup>3</sup> USE POT

# AN-1074



## BOM 58W/T8, Passive Valley fill, 220/240 VAC

Item #	Qt	Manufacturer	Part Number	Description	Reference
1	8		10DF6	Rectifier, 1A 600V	DBR1, DBR2, DBR3, DBR4, D1, D2, D3, DBOOT
2	1	Roederstein	F1772433-2200	Capacitor, 0.33uF, 275VAC	C1
3	1	Panasonic	ELF-15N007A	EMI Inductor, 1X10mH 0.7Apk	L1
4	2	WIMA	MKP10	Capacitor, 0.22uF, 400VDC	CDC, C2
5	2			Capacitor, 100uF, 250V	C4, C5
6	1			Resistor, 46K ohm	R6 <sup>1</sup>
7	1			Resistor, 430K	R2
8	1			Resistor, 20K	R3
9	1			Resistor, 100ohm, 1W	R1
10	2			Capacitor, 0.1uF SMT1206	CVCC1, CBOOT
11	1	Panasonic	ECE-A1HGE02R2	Capacitor, 2.2uF 50VDC	CVCC2
12	2	International Rectifier	IRF840	Transistor, MOSFET	MLS, MHS
13	2	Panasonic	ERJ-8GEYJ22	Resistor, 22 ohm SMT 1206	RLO, RHO
14	1		PN2222A	Transistor NPN	T1
15	1			Resistor, 22K Ohm	RT <sup>2</sup>
16	1			Resistor, 18K Ohm	RPH <sup>3</sup>
17	1			Resistor, 1K ohm, SMT1206	RLIM1
18	1			Capacitor, 560pF, SMT1206	CT
19	1			Capacitor, 0.39uF, SMT1206	CPH
20	1			Resistor, 0.22 Ohm 1/2W	RCS
21	1			Capacitor, 470pF SMT1206	CCS
22	1	Diodes	LL4148DICT-ND	Diode, 1N4148 SMT DL35	DCP2
23	1			18V Zener Diode	DCP1
24	1			Capacitor, 1.5nF 1.6KV, 1812	CSNUB
25	1			Capacitor, 22nF 1600V	CRES
26	1	International Rectifier	IR2156	IC, Ballast Driver w/PFC	IC BALLAST
27	1			Inductor, 0.4mH 3Apk	LRES
28	1			Resistor, 147K ohm 1/2W	RSUPPLY
29	1			Resistor, 100K ohm	RDC
30	1			Fuse, 0.5 ohm, 1/2 W	F1
Total	42				

JCT, JRT are in  
CY and RV1 not mounted

<sup>4</sup> USE POT

<sup>5</sup> USE POT

<sup>6</sup> USE POT

**Schematic**

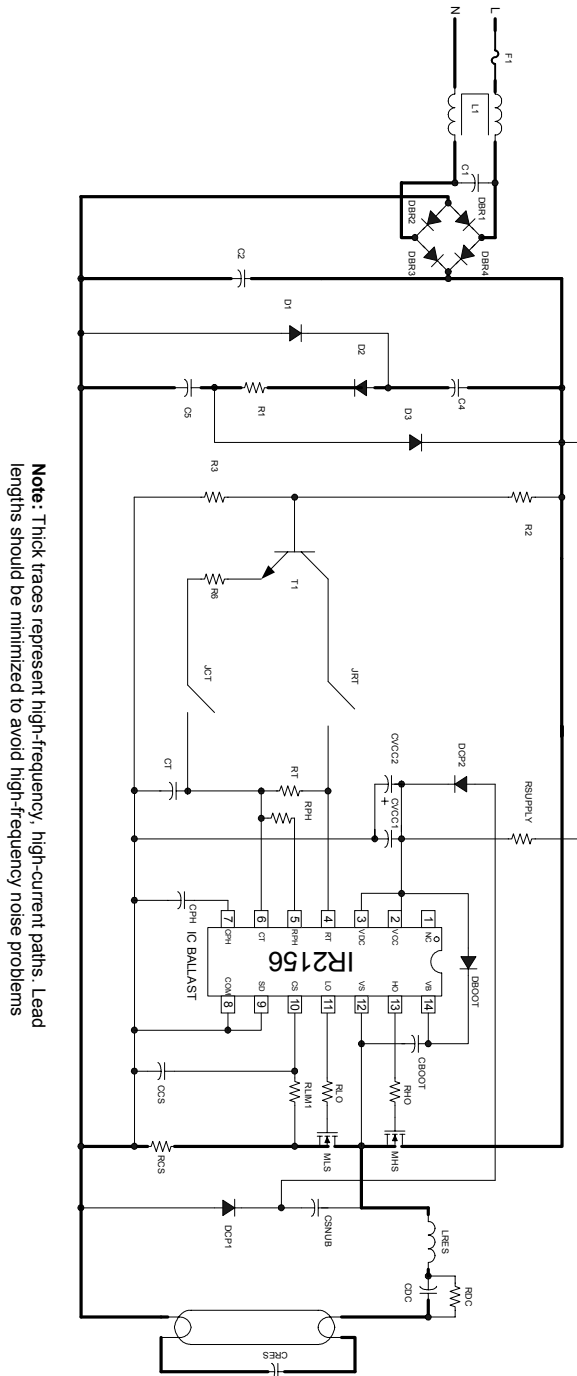

**ce**  
 switches ON for freq.  
 Modulation enabled

**Note:** Thick traces represent high-frequency, high-current paths. Lead lengths should be minimized to avoid high-frequency noise problems