

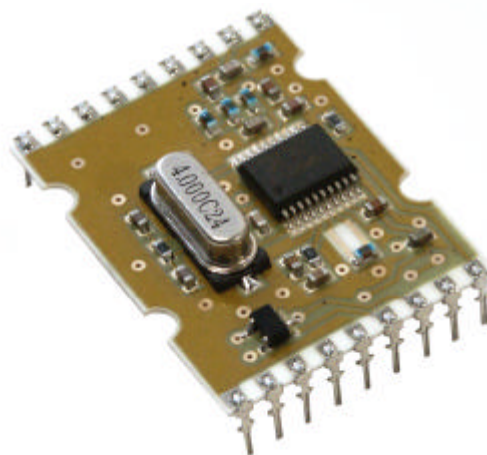

- FM Radio Transmitter & Receiver
- Low Profile Ceramic DIL Package
- Data Rates To 20 Kbits/S
- 433.92 or 433.33MHz Operation
- 2 Selectable RF Channels
- Narrowband Crystal Controlled
- Optimal Range 200m
- Supply Voltage 3-5V
- Very Stable Operating Frequency
- Operates from  $-20$  to  $+70^{\circ}\text{C}$
- Standby Mode 8uA



## Applications

- Wireless Security Systems
- EPOS Terminals
- Sensor Data logging
- Remote Telemetry & Telecommand
- Remote Meter Reading

## Description

The RXQ1 radio transceiver module provides reliable wireless operation. Its unique features of channel selection and interference rejection make the RXQ1 an ideal choice for next generation applications. Operating within the 433.92MHz, the RXQ1 can operate a two narrow band channels; 433.92 and 433.33MHz. The module uses a 'crystal controlled' design providing narrow band performance, far superior than other wideband 'SAW' based designs

These modules will suit one-to-one and multi-node wireless links in applications including car and building security, EPOS and inventory tracking, remote industrial process monitoring and computer networking. Because of their small size and low power requirements, both modules are ideal for use in portable, battery-powered applications such as hand-held terminals.

## Part Numbering

Part Number	Description
FM-RXQ1-433	Transceiver Module 433MHz



## Absolute Maximum Ratings

Operating temperature: -20 °C to +70 °C  
Storage temperature: -40 °C to +100 °C

Supply Voltage -0.3 to 6V  
Data input -0.3 to Vcc + 0.3v

## Electrical Characteristics:

	Min.	Typ.	Max.	Units	Notes
<b>DC Levels</b>					
Supply voltage	2.7	3	5.25	V	1
Supply current (Transmit Mode)		26		mA	
Supply current (Receive Mode)		12		mA	
Supply current (Standby Mode)		8		uA	
Data input/output high	0.7xVcc		Vcc	V	
Data input/output low	0		0.3xVcc	V	
<b>RF</b>					
Working Frequency		433.92 / 433.33		MHz	
Receiver sensitivity		-100		dBm	
RF power out (transmitter)		5		dBm	Into 50Ω
FM Deviation		+/- 15		KHz	
IF Bandwidth	65		85	KHz	
Harmonic Spurious Emissions		-50		dBc	
Operating Temperature	-20		+70	Deg C	
<b>Dynamic Timing</b>					
Power up to stable receiver data out		5		mS	2
Power up to full RF out		4		mS	2
Standby to RX mode		3		mS	
Standby to TX mode		2		mS	
Changing from TX to RX mode		3		mS	
Changing from RX to TX mode		1		uS	
Data Bit rate	20		20,000	bps	

## Notes

1. Supply voltage should have <10mV ripple.



## Mechanical Dimensions

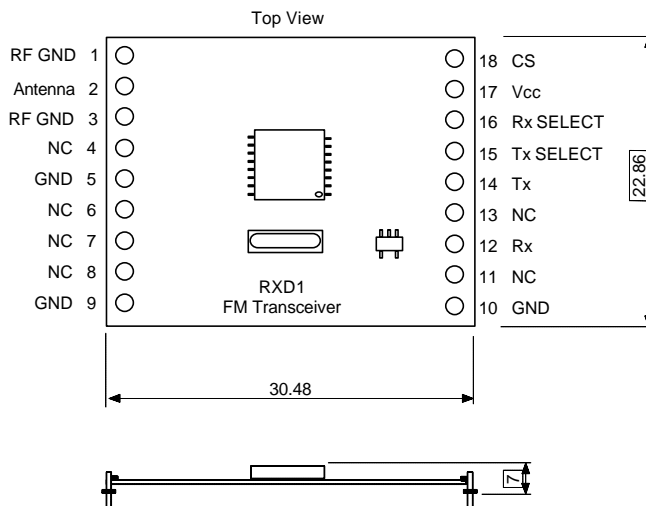

## Pin Descriptions

### RF GND (pins 1,3)

For best results, these pins should be connected to the ground plane against which the antenna radiates.

### Antenna (pin 2)

Nominal 50 ohm input/output impedance capacitively isolated from the internal circuit.

### GND (pins 5, 9,10)

Supply ground points

### NC (pin 4, 6, 7, 8, 11,13)

No connection

### Rx (pin 12)

Receiver digital data output (CMOS logic out) representing true data as supplied to the transmitter.

### Tx (pin 14)

Data input to the transmitter can be directly interfaced to CMOS logic drive operating on the same supply voltage as the transceiver.

### Tx Select (pin 15)

Active LOW Transmit select

### Rx Select (pin 16)

Active LOW Receive select

### Vcc (pin 17)

Supply voltage range from 2.7 to 5.25volts.

### Channel Select (pin 18)

Data 0 selects 433.92MHz  
Data 1 selects 434.33MHz.

## Operation Table

Tx Select	RX Select	Function
0	0	Power Down Mode
0	1	Transmit Mode
1	0	Receive Mode
1	1	Power Down Mode



## Antenna Design

The design and positioning of the antenna is as crucial as the module performance itself in achieving a good wireless system range. The following will assist the designer in maximising system performance.

The antenna should be kept as far away from sources of electrical interference as physically possible. If necessary, additional power line decoupling capacitors should be placed close to the module.

The antenna 'hot end' should be kept clear of any objects, especially any metal as this can severely restrict the efficiency of the antenna to receive power. Any earth planes restricting the radiation path to the antenna will also have the same effect.

Best range is achieved with either a straight piece of wire, rod or PCB track @  $\frac{1}{4}$  wavelength (15.5cm @ 433.92MHz). Further range may be achieved if the  $\frac{1}{4}$  wave antenna is placed perpendicular in the middle of a solid earth plane measuring at least 16cm radius. In this case, the antenna should be connected to the module via some 50 ohm characteristic impedance coax

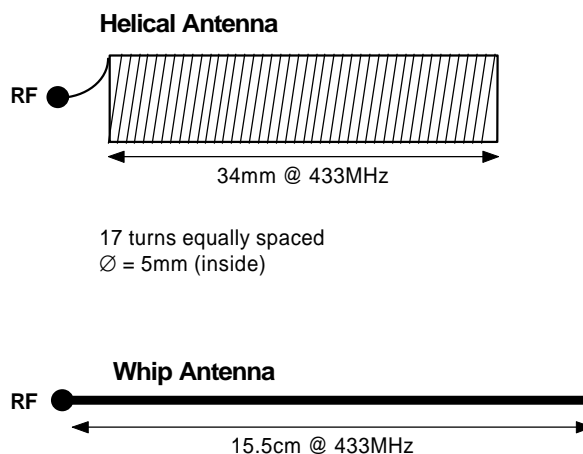
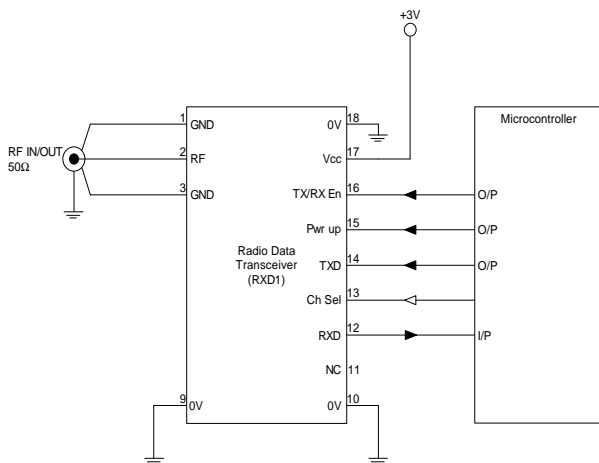

Figure 2: Antenna Configurations To Be Used With The FM Transceiver Module



## Application Information



Note: Select a microcontroller clock frequency to avoid harmonics on receive frequency  
Provide ground plane around microcontroller

Figure 3: FM Transceiver Application Circuit

The RXQ1 radio transceiver is a true data in data out module. Generally data to be transmitted should be formed into a series of “packets”. The exact format of packets are application and system specific but as an example, the following format is a good example of how to design a robust “packet” protocol.

Preamble + Start + Address + Data +Checksum

**Preamble:** This consists of a data clock at the same baud rate as the subsequent data. It’s function is to stabilise the data slicer in the receiver end of a transceiver.

**Start:** This byte is usually used as a frame sync. Indicating the start of the message. It may also contain additional information such as a number of packets being transmitted, scramble information, flow control etc.

**Address:** This byte contains identification information about the host node. The number of bits used here is dependent upon the system requirements such as the number of nodes etc. Typically, a 16 to 24 bit source address may be used.

**Data:** The data is usually limited to about 50 bytes. Keeping the data to a minimum length required will minimise repeat overheads due to errors occurring in the data received.

**Checksum:** A CRC or checksum is used here to verify the integrity of the packet.

**RF Solutions Ltd.,  
Unit 21, Cliffe Industrial Estate,  
South Street,  
Lewes,  
E Sussex, BN8 6JL. England**

**Tel +44 (0)1273 898 000 Fax +44 (0)1273 480 661**

**Email [sales@rfsolutions.co.uk](mailto:sales@rfsolutions.co.uk)**

**<http://www.rfsolutions.co.uk>**

*RF Solutions is a member of the Low Power Radio Association*

All Trademarks acknowledged and remain the property of the respected owners

Information contained in this document is believed to be accurate, however no representation or warranty is given and R.F. Solutions Ltd. assumes no liability with respect to the accuracy of such information. Use of R.F.Solutions as critical components in life support systems is not authorised except with express written approval from R.F.Solutions Ltd.