

CAD NOTE: SMIL TRACE 15MIL SPACE
PRCOMP R119 40.2B \rightarrow VCC18
GRCOMP R118 40.2B
HXRCOMP R87 24.9B
HYRCOMP R82 24.9B
 CAD NOTE: NEAR THE MCH (<500MIL)

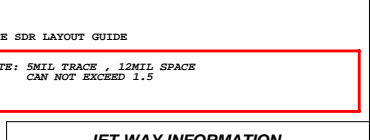
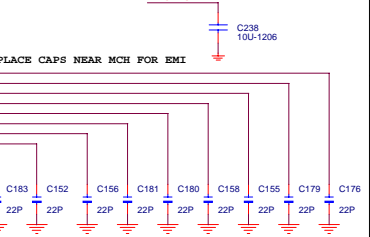
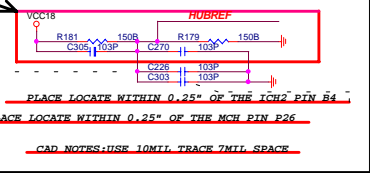
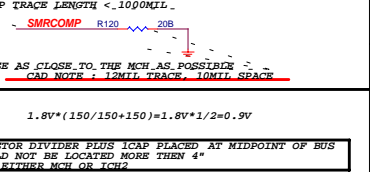
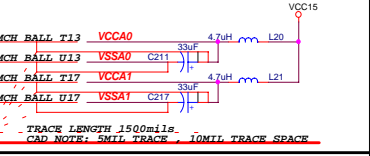
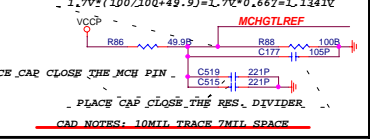
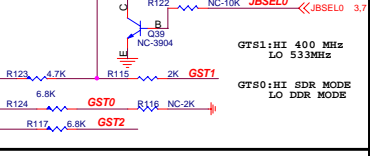
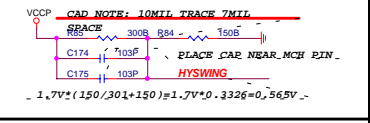

JET WAY INFORMATION

File	845MCH	
Size	Document Number	845CA
Date:	Friday, December 28, 2001	Sheet 2 of 15
Rev	3.0	

1-2 3-4
 ON OFF AUTO
 OFF ON 100
 OFF OFF 133

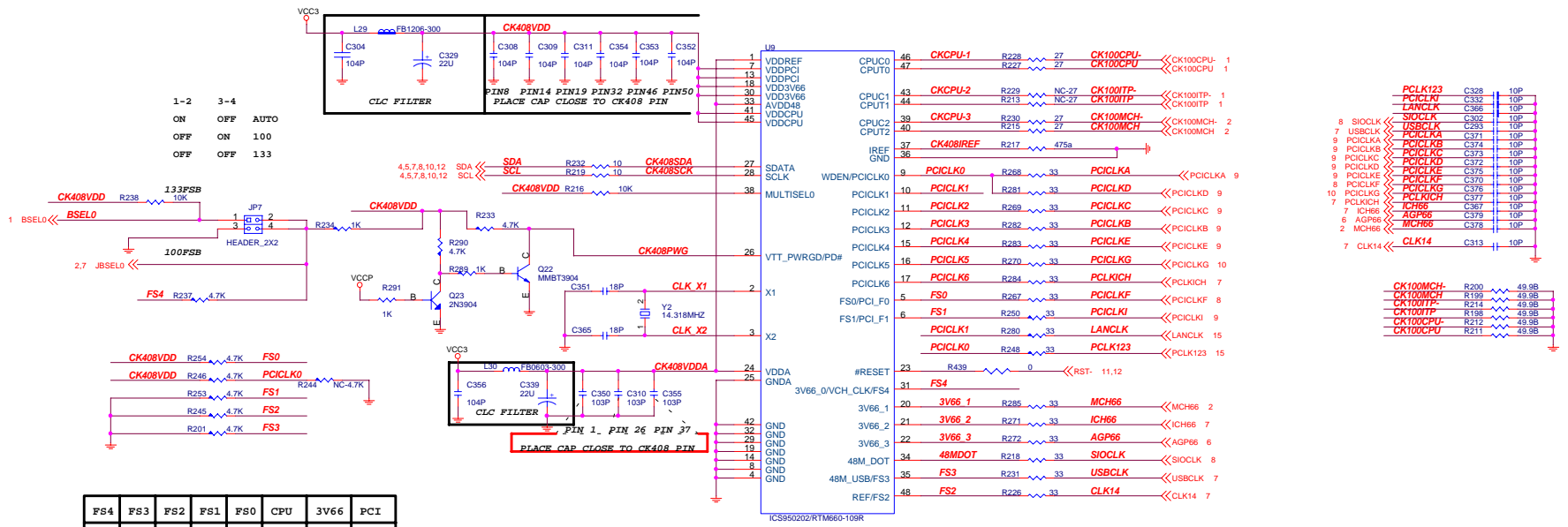

FS4	FS3	FS2	FS1	FS0	CPU	3V66	PCI
0	0	0	0	1	100	66.6	33.3
1	0	0	0	1	133	66.6	33.3
1	1	1	1	0	66.6	66.6	33.3
1	1	1	1	1	200	66.6	33.3

PIN9: ICS950202 PULL HI: ENABLE WATCHDOG
 PIN9: RTM660-109R PULL HI: DISABLE WATCHDOG

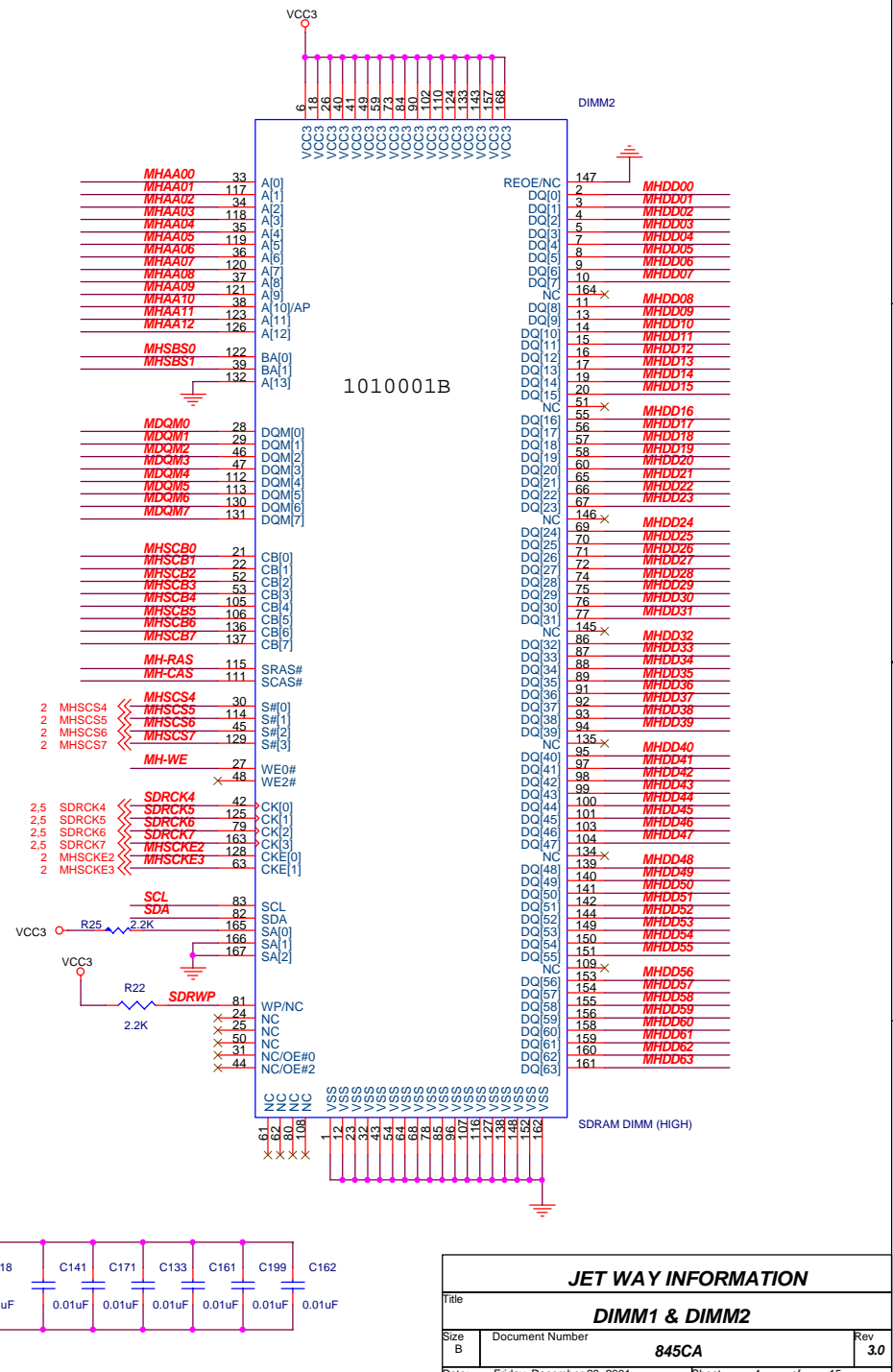
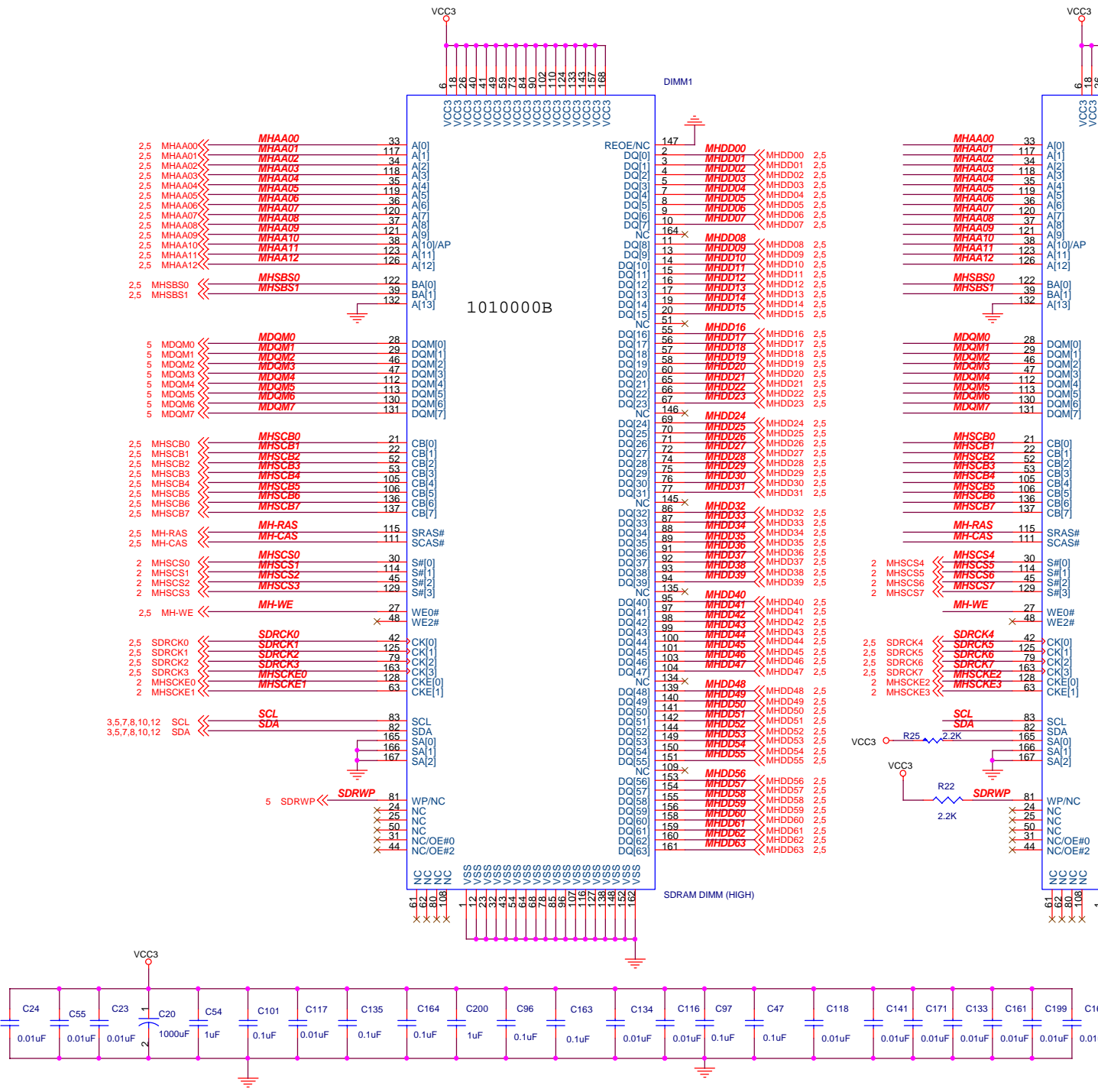

JET WAY INFORMATION		
Title DIMM1 & DIMM2		
Size B	Document Number 845CA	Rev 3.0
Date: Friday, December 28, 2001	Sheet 4	of 15

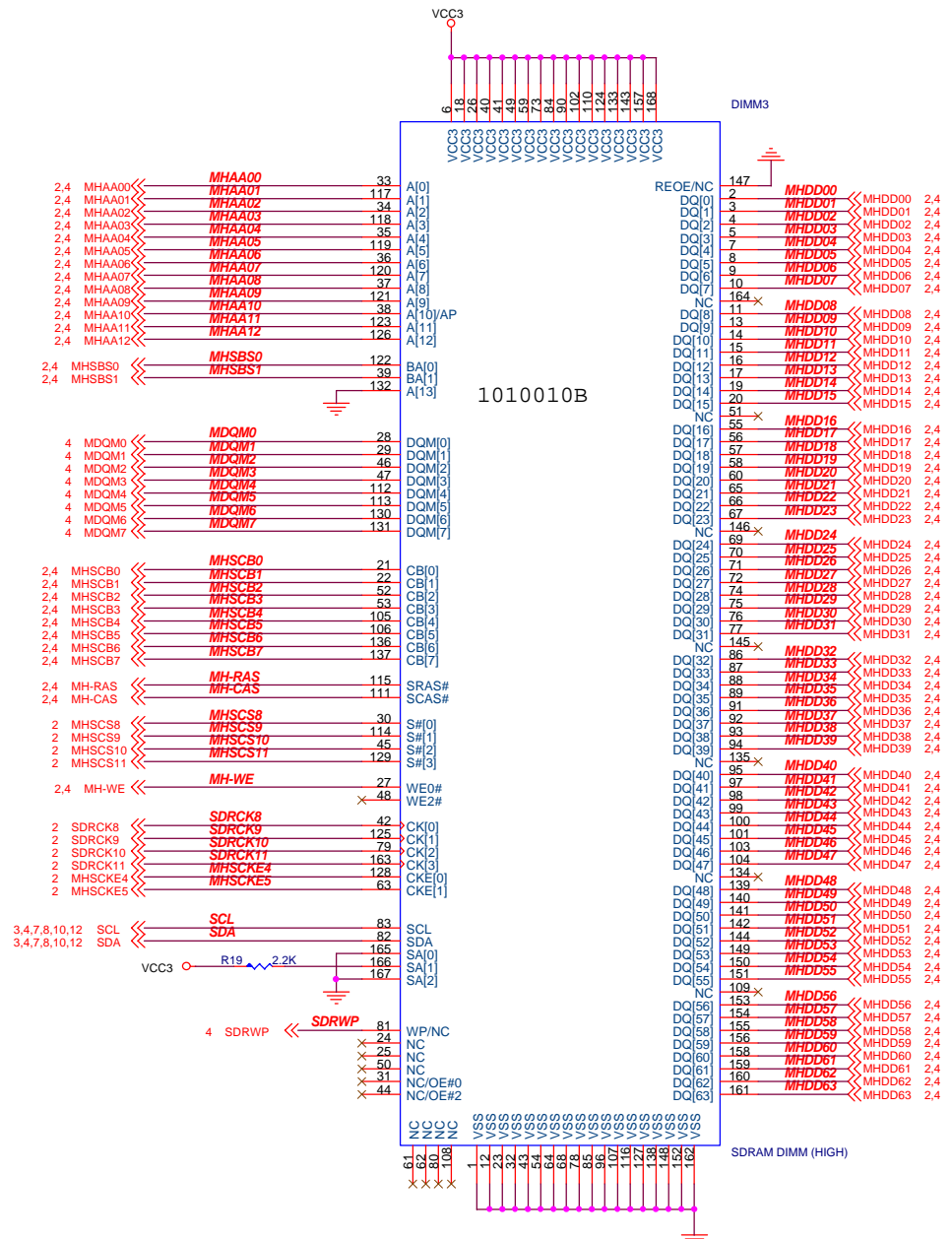

1010010B

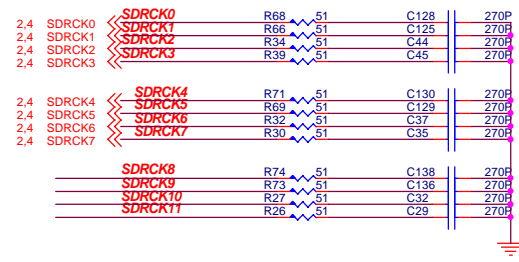
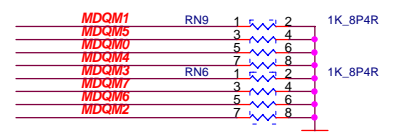

PLACE THOSE PARTS BELOW
3RD DIMM FOR TERMINATION

JET WAY INFORMATION		
Title	DIMM3	
Size B	Document Number	Rev
	845CA	3.0
Date:	Friday, December 28, 2001	Sheet 5 of 15

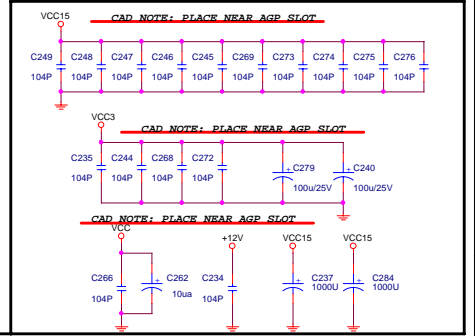
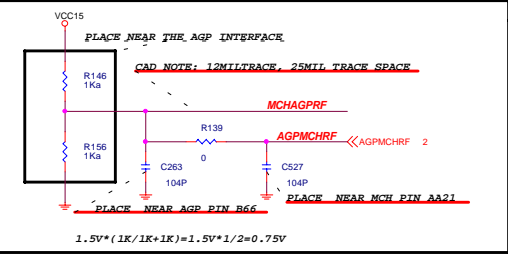
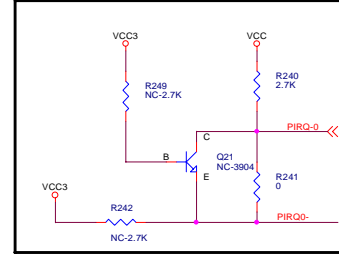
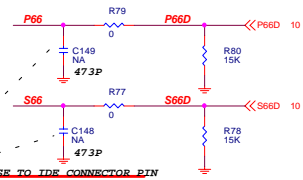
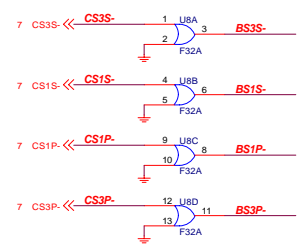
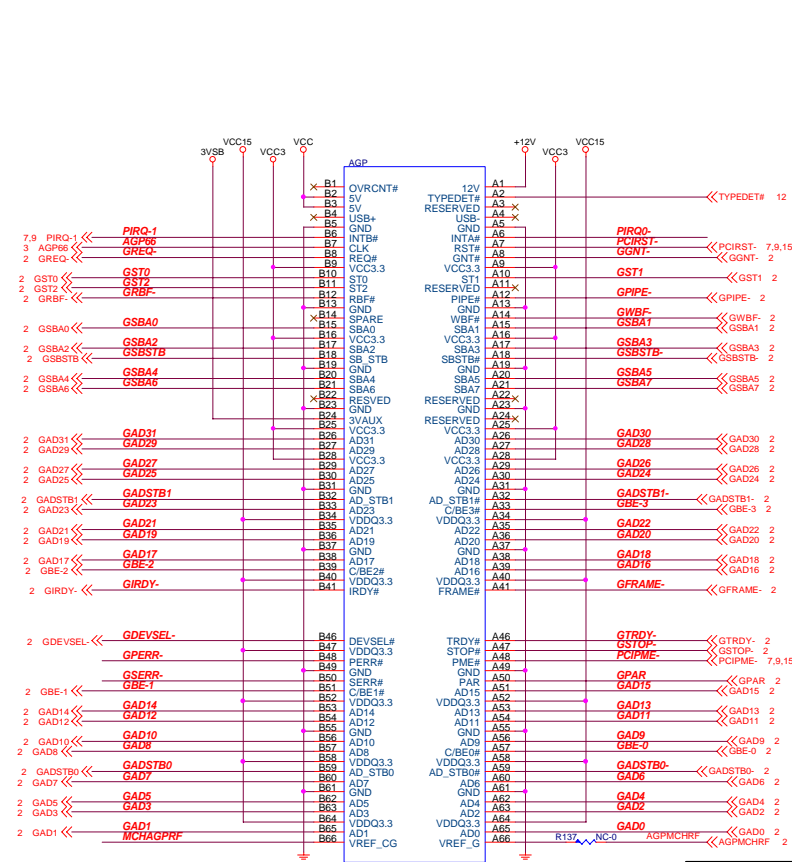
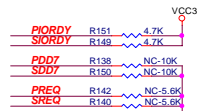
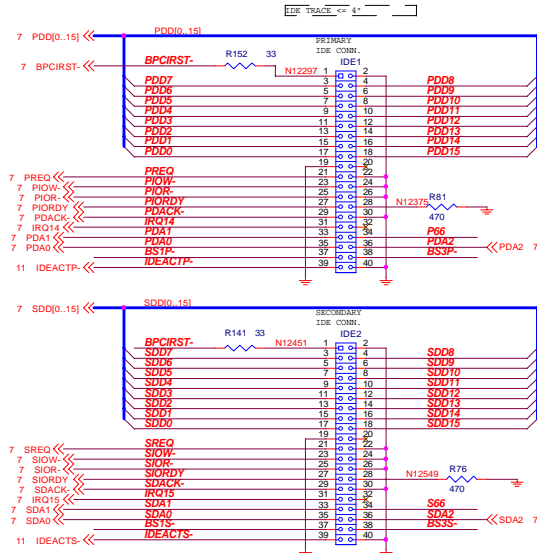

Signals	Maximum Length	Trace Spacing (0.8 Mil Trace)	Length Mismatch	Relative To	Notes
1X Timing Domain	7.5"	10 Mils	N/A	N/A	NONE
2X/4X Timing Domain Set#1	6"	15 Mils	+ / - 0.25"	GADSTB0- GADSTB0-	GADSTB0 AND GADSTB0- Must be same length
2X/4X Timing Domain Set#2	6"	15 Mils	+ / - 0.25"	GADSTB1- GADSTB1-	GADSTB1 AND GADSTB1- Must be same length
2X/4X Timing Domain Set#3	6"	15 Mils	+ / - 0.25"	GSBSTB GSBSTB-	GSBSTB AND GSBSTB- Must be same length

- 1X TIMING DOMAIN SIGNALS**
- GFRAME-
 - GIRDY-
 - GDEVSEL-
 - GSTOP-
 - GTRDY-
 - GSTOP-
 - GTRDY-
 - GSTOP-
 - GTRDY-
 - GSTOP-
 - GTRDY-
 - GSTOP-
 - GTRDY-
 - GSTOP-
- MISCELLANEOUS SIGNALS**
- USBAGP+
 - USBAGP-
 - AGPOC-
 - PCIPME-
 - TYPEDET-
 - GPERF-
 - GPERF-
 - PIRQ0-
 - PIRQ1-
- 2X/4X TIMING DOMAIN**
- ROUTE 5 ON 15 FOR STROBE SIGNAL (1 : 3)
 - STROBE SIGNAL TO OTHERS 5 ON 20 (1 : 4)
 - GAD[0..31]
 - GSB[0..31]
 - GADSTB0-
 - GADSTB1-
 - GADSTB1-
 - GSBA[0..7]
 - GSBSTB-
 - GSBSTB-

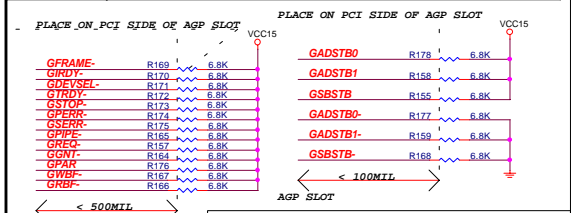

JET WAY INFORMATION

AGP4X / IDE

File: _____

Size: _____

C: _____

Date: Friday, December 28, 2001

Document Number: **845CA**

Sheet: **8** of **15**

Rev: **3.0**

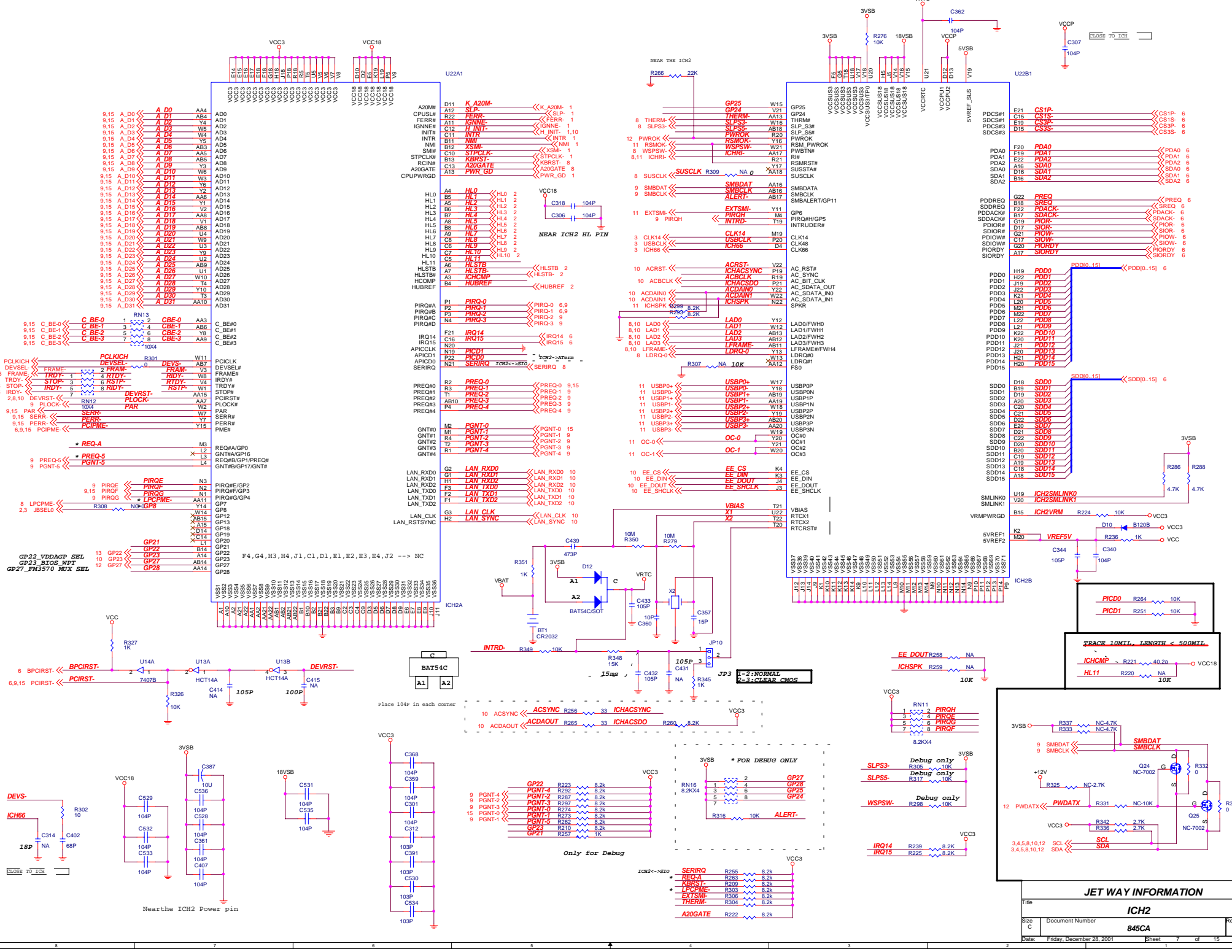

9.15 A.D0	A D0	AA4	ADD
9.15 A.D1	A D1	AB4	AD1
9.15 A.D2	A D2	Y4	AD2
9.15 A.D3	A D3	W5	AD3
9.15 A.D4	A D4	Y5	AD4
9.15 A.D5	A D5	Y1	AD5
9.15 A.D6	A D6	AB3	AD6
9.15 A.D7	A D7	AB5	AD7
9.15 A.D8	A D8	Y3	AD8
9.15 A.D9	A D9	W6	AD9
9.15 A.D10	A D10	W3	AD10
9.15 A.D11	A D11	AD11	AD11
9.15 A.D12	A D12	Y2	AD12
9.15 A.D13	A D13	AA6	AD13
9.15 A.D14	A D14	Y4	AD14
9.15 A.D15	A D15	Y1	AD15
9.15 A.D16	A D16	AA8	AD16
9.15 A.D17	A D17	Y1	AD17
9.15 A.D18	A D18	AB8	AD18
9.15 A.D19	A D19	AB9	AD19
9.15 A.D20	A D20	U4	AD20
9.15 A.D21	A D21	U3	AD21
9.15 A.D22	A D22	U2	AD22
9.15 A.D23	A D23	U9	AD23
9.15 A.D24	A D24	U2	AD24
9.15 A.D25	A D25	U2	AD25
9.15 A.D26	A D26	W10	AD26
9.15 A.D27	A D27	T4	AD27
9.15 A.D28	A D28	Y10	AD28
9.15 A.D29	A D29	T9	AD29
9.15 A.D30	A D30	T9	AD30
9.15 A.D31	A D31	AA10	AD31

9.15 C.BE-0	C BE-0	1	RN13	C.BE-0	AA3	C.BE-0
9.15 C.BE-1	C BE-1	3	2	C.BE-1	AB6	C.BE-1
9.15 C.BE-2	C BE-2	5	6	C.BE-2	Y8	C.BE-2
9.15 C.BE-3	C BE-3	7	8	C.BE-3	AA9	C.BE-3

3 PCLKICH	PCLKICH	R301	W11	PCCLK	W11
9.15 DEVSEL	DEVSEL	0	DEVSEL	AB7	DEVSEL
9.15 FRAME	FRAME	2	FRAME	W3	FRAME
9.15 TRDY	TRDY	1	TRDY	W5	TRDY
9.15 STOP	STOP	3	TRDY	V4	STOP
9.15 IRDY	IRDY	5	8	IRDY	W1
9.15 DEVRT	DEVRT	10	DEVRT	AA15	STOP
9.15 PLOCK	PLOCK	AA7	PLOCK	AA7	PLOCK
9.15 SERR	SERR	W7	SERR	W7	SERR
9.15 PERR	PERR	Y7	PERR	Y7	PERR
6.9.15 PCIPME	PCIPME	Y15	PME	Y15	PME

9 REQ-A	REQ-A	M3	REQA/GP9
9 REQ-S	REQ-S	X2	GNTR/GP16
9 PNT-5	PNT-5	L4	REQB/GP1/PREQ#
9 PNT-6	PNT-6	L4	GNTR/GP17/GNT#

9 LAN_RXD0	LAN_RXD0	G1	LAN_RXD0
9 LAN_RXD1	LAN_RXD1	G2	LAN_RXD1
9 LAN_RXD2	LAN_RXD2	G3	LAN_RXD2
9 LAN_TXD0	LAN_TXD0	F1	LAN_TXD0
9 LAN_TXD1	LAN_TXD1	F2	LAN_TXD1
9 LAN_TXD2	LAN_TXD2	F3	LAN_TXD2

13 GP22	GP22	G14	GP22
14 GP23	GP23	A14	GP23
15 GP24	GP24	AB14	GP24
12 GP27	GP27	AB14	GP27
12 GP28	GP28	AA14	GP28

6 BPCIRST	BPCIRST	1	U14A	HCT14A	U13A	HCT14A
6.9.15 PCIRST	PCIRST	2	U14A	HCT14A	U13B	HCT14A

A20M#	D11	K A20M-	K A20M- 1
CPUSL#	A12	SLP	SLP CLP- 1
IGNNE#	R22	FERR	FERR- 1
INTR#	C12	H INIT	IGNNE- 1
INTR	C11	INTR	INTR 1
NMI	B12	XSMI	NMI 1
SMI#	C13	NMI	SMI# 1
STPCLK#	B13	ADST	STPCLK- 1
RCM#	A20GATE	ADST	ADST# 8
A20GATE	A13	PWR GD	PWR GD 1

HL0	A4	HL0	HL0 2
HL1	B5	HL1	HL1 2
HL2	B6	HL2	HL2 2
HL3	B7	HL3	HL3 2
HL4	A8	HL4	HL4 2
HL5	B8	HL5	HL5 2
HL6	A9	HL6	HL6 2
HL7	C8	HL7	HL7 2
HL8	C9	HL8	HL8 2
HL9	C7	HL9	HL9 2
HL10	C6	HL10	HL10 2
HL11	C5	HL11	HL11 2

PIRQ0A	P1	PIRQ-0	PIRQ-0 6.9
PIRQ0B	P2	PIRQ-1	PIRQ-1 6.9
PIRQ0C	P3	PIRQ-2	PIRQ-2 6.9
PIRQ0D	P4	PIRQ-3	PIRQ-3 9

PREQ0	R2	PREQ-0	PREQ-0 9.15
PREQ1	R3	PREQ-1	PREQ-1 9
PREQ2	AB10	PREQ-2	PREQ-2 9
PREQ3	PA	PREQ-3	PREQ-3 9
PREQ4	PA	PREQ-4	PREQ-4 9

GP25	W15	GP25	GP25
GP26	W16	GP26	GP26
GP27	W17	GP27	GP27
GP28	W18	GP28	GP28
GP29	W19	GP29	GP29
GP30	W20	GP30	GP30
GP31	W21	GP31	GP31
GP32	W22	GP32	GP32
GP33	W23	GP33	GP33
GP34	W24	GP34	GP34
GP35	W25	GP35	GP35
GP36	W26	GP36	GP36
GP37	W27	GP37	GP37
GP38	W28	GP38	GP38
GP39	W29	GP39	GP39
GP40	W30	GP40	GP40
GP41	W31	GP41	GP41
GP42	W32	GP42	GP42
GP43	W33	GP43	GP43
GP44	W34	GP44	GP44
GP45	W35	GP45	GP45
GP46	W36	GP46	GP46
GP47	W37	GP47	GP47
GP48	W38	GP48	GP48
GP49	W39	GP49	GP49
GP50	W40	GP50	GP50
GP51	W41	GP51	GP51
GP52	W42	GP52	GP52
GP53	W43	GP53	GP53
GP54	W44	GP54	GP54
GP55	W45	GP55	GP55
GP56	W46	GP56	GP56
GP57	W47	GP57	GP57
GP58	W48	GP58	GP58
GP59	W49	GP59	GP59
GP60	W50	GP60	GP60
GP61	W51	GP61	GP61
GP62	W52	GP62	GP62
GP63	W53	GP63	GP63
GP64	W54	GP64	GP64
GP65	W55	GP65	GP65
GP66	W56	GP66	GP66
GP67	W57	GP67	GP67
GP68	W58	GP68	GP68
GP69	W59	GP69	GP69
GP70	W60	GP70	GP70
GP71	W61	GP71	GP71
GP72	W62	GP72	GP72
GP73	W63	GP73	GP73
GP74	W64	GP74	GP74
GP75	W65	GP75	GP75
GP76	W66	GP76	GP76
GP77	W67	GP77	GP77
GP78	W68	GP78	GP78
GP79	W69	GP79	GP79
GP80	W70	GP80	GP80
GP81	W71	GP81	GP81
GP82	W72	GP82	GP82
GP83	W73	GP83	GP83
GP84	W74	GP84	GP84
GP85	W75	GP85	GP85
GP86	W76	GP86	GP86
GP87	W77	GP87	GP87
GP88	W78	GP88	GP88
GP89	W79	GP89	GP89
GP90	W80	GP90	GP90
GP91	W81	GP91	GP91
GP92	W82	GP92	GP92
GP93	W83	GP93	GP93
GP94	W84	GP94	GP94
GP95	W85	GP95	GP95
GP96	W86	GP96	GP96
GP97	W87	GP97	GP97
GP98	W88	GP98	GP98
GP99	W89	GP99	GP99
GP100	W90	GP100	GP100

AC_RST#	Y22	AC_RST#	AC_RST#
AC_SYNC	R19	AC_SYNC	AC_SYNC
AC_BIT_CLK	R19	AC_BIT_CLK	AC_BIT_CLK
AC_SDATA_OUT	P21	AC_SDATA_OUT	AC_SDATA_OUT
AC_SDATA_IN0	Y22	AC_SDATA_IN0	AC_SDATA_IN0
AC_SDATA_IN1	Y22	AC_SDATA_IN1	AC_SDATA_IN1
SPKR	N22	SPKR	SPKR

USBP0+	W17	USBP0+	USBP0+
USBP0-	W18	USBP0-	USBP0-
USBP1+	AB19	USBP1+	USBP1+
USBP1-	AA19	USBP1-	USBP1-
USBP2+	W19	USBP2+	USBP2+
USBP2-	AB20	USBP2-	USBP2-
USBP3+	AB20	USBP3+	USBP3+
USBP3-	AA20	USBP3-	USBP3-
OC0	W19	OC0	OC0
OC1	Y20	OC1	OC1
OC2	Y21	OC2	OC2
OC3	W20	OC3	OC3

EE_CS	K4	EE_CS	EE_CS
EE_DIN	J4	EE_DIN	EE_DIN
EE_DOUT	J4	EE_DOUT	EE_DOUT
EE_SHCLK	J3	EE_SHCLK	EE_SHCLK

JET WAY INFORMATION
 ICH2
 84SCA
 Rev 3.0

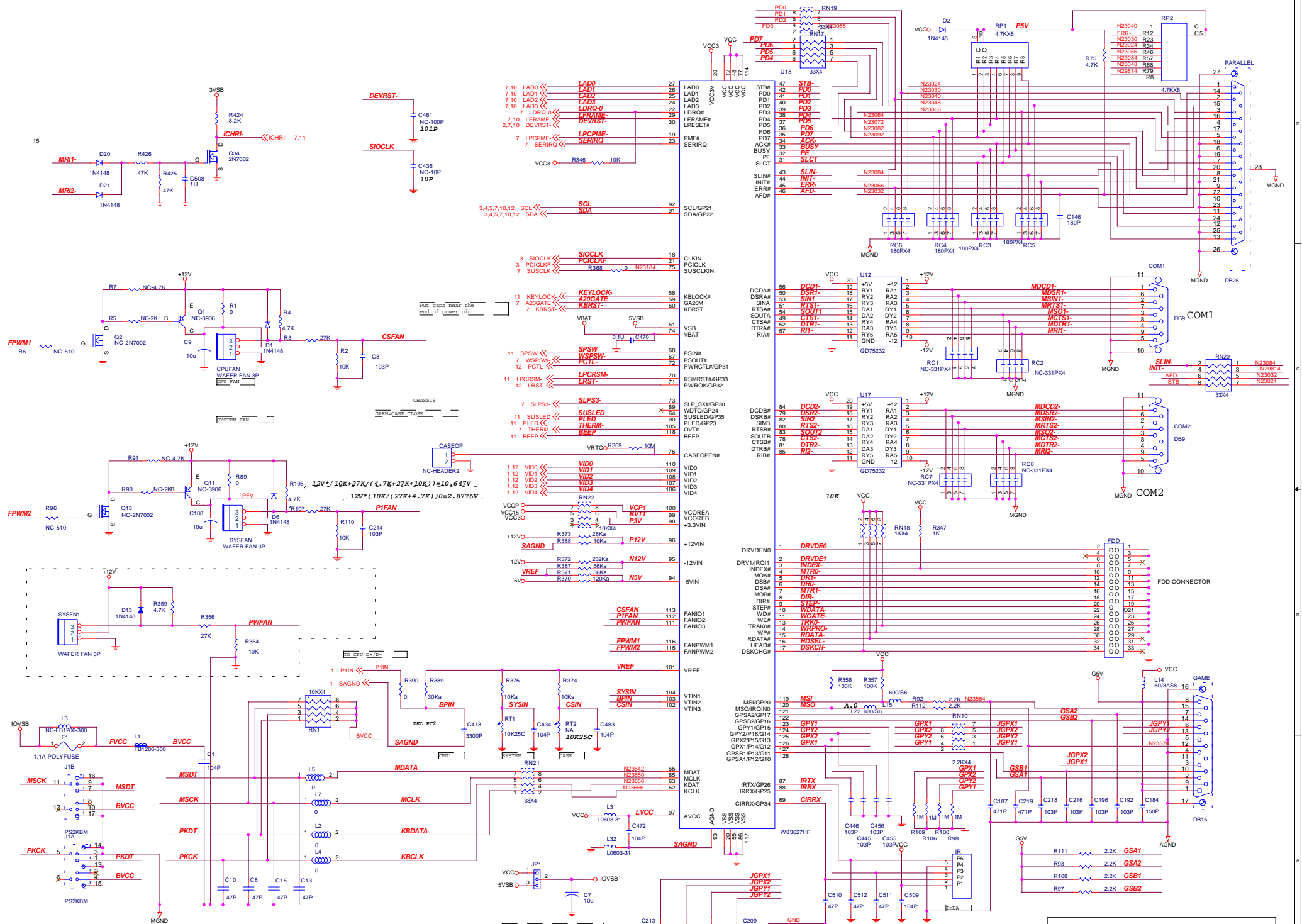

JET WAY INFORMATION			
File	SUPER IO		
Doc	Document Number	845CA	Rev. 3.0
Date:	Friday, December 28, 2001	Sheet	8 of 8

15 PREQ-0A << PREQ-0A

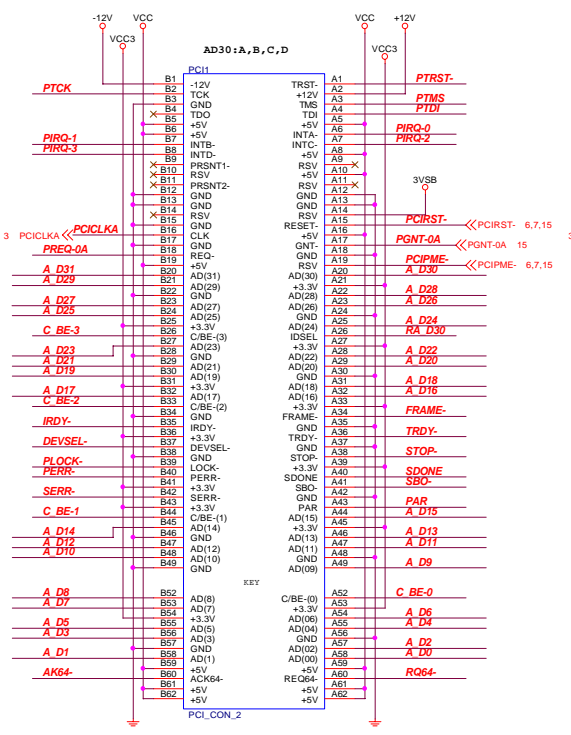

AD25:B,C,D,A

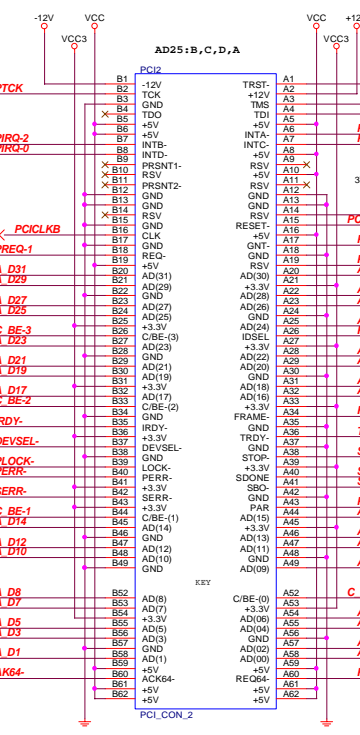

AD26:C,D,A,B

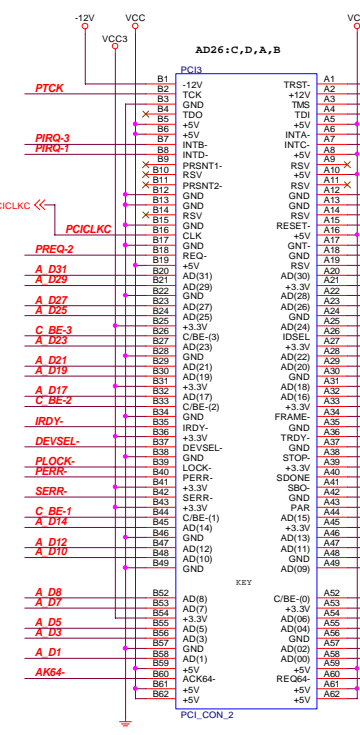

AD27:D,A,B,C

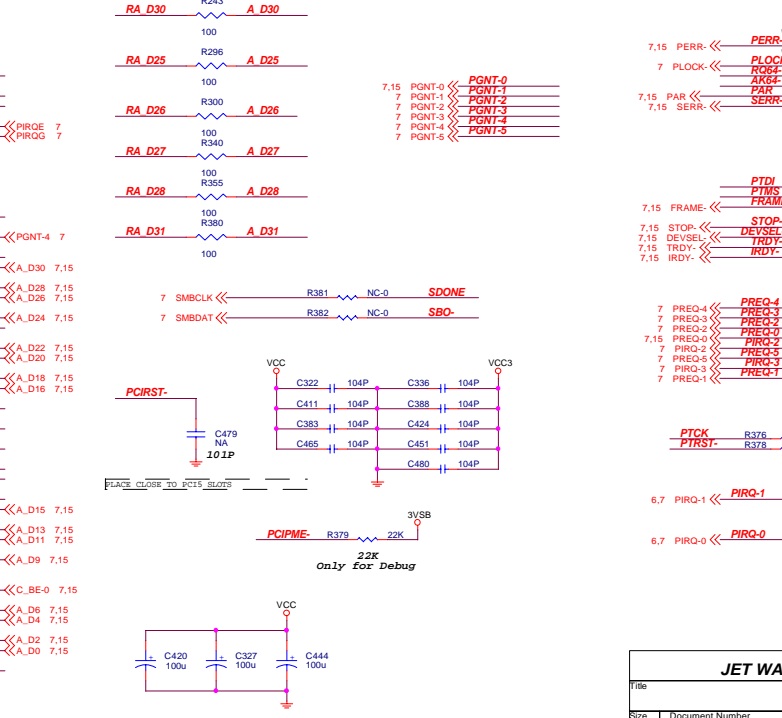
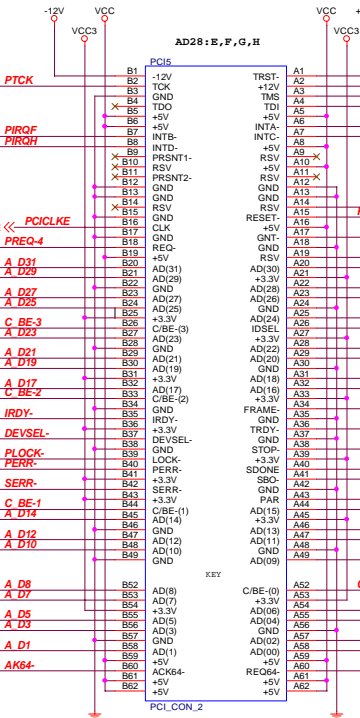
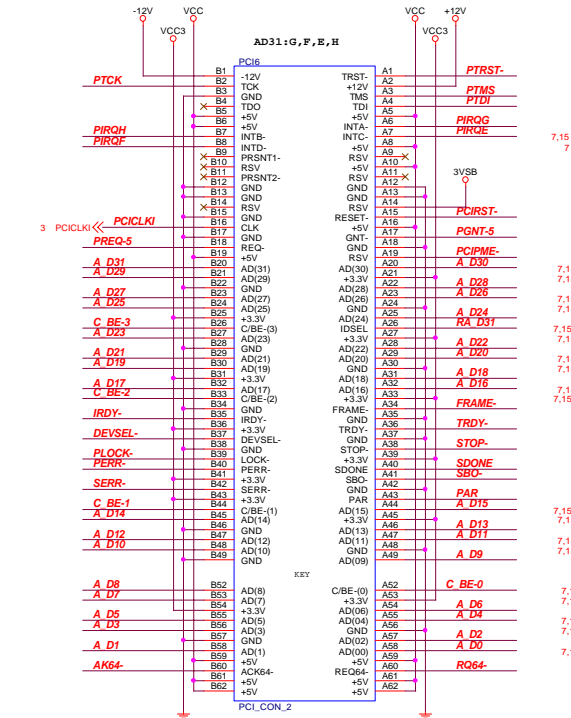
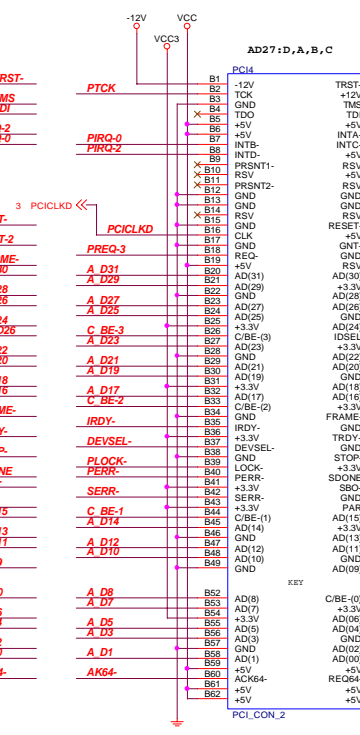

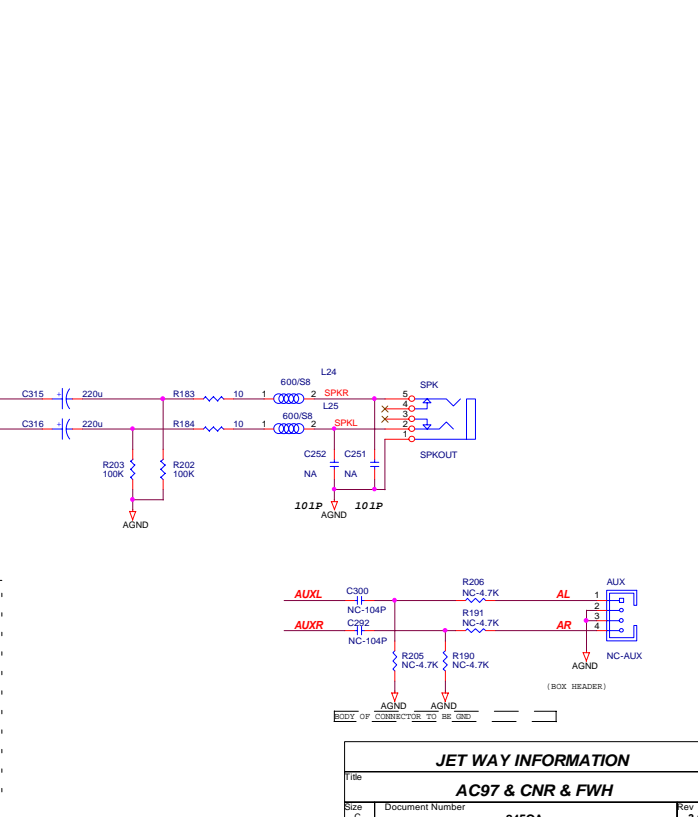
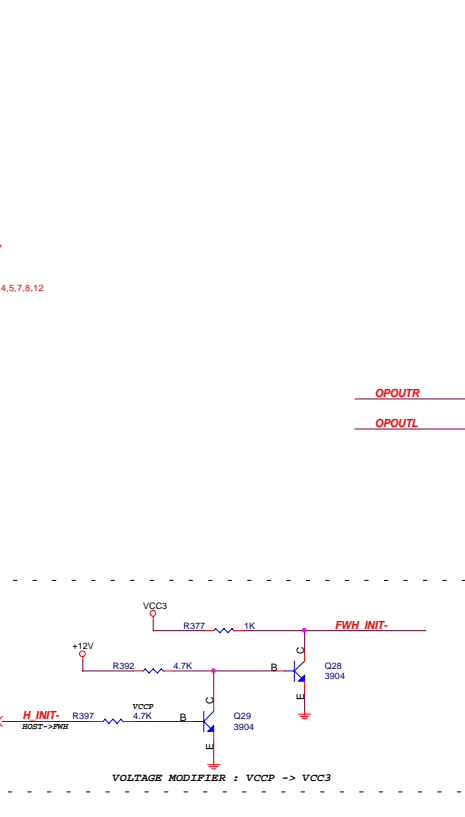
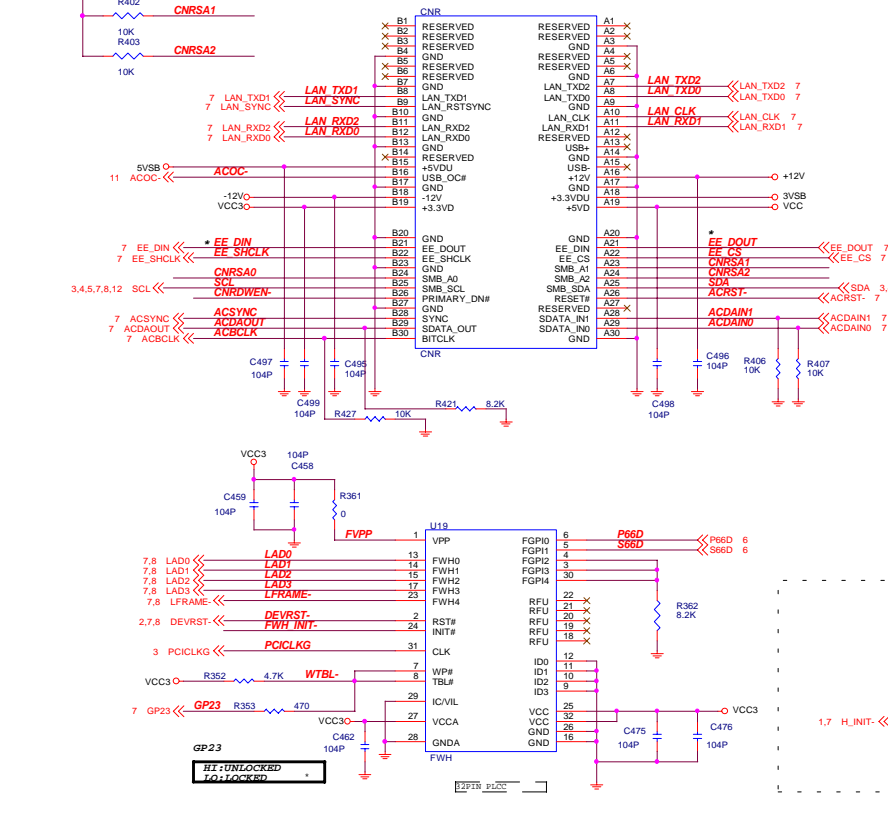
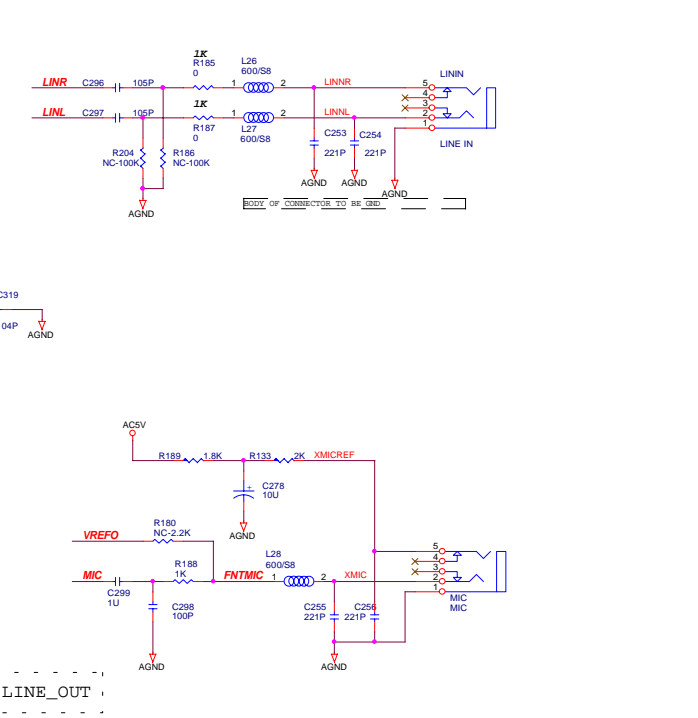
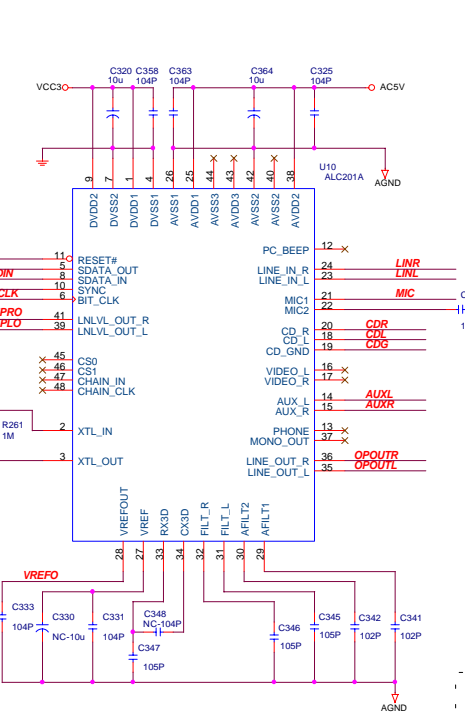
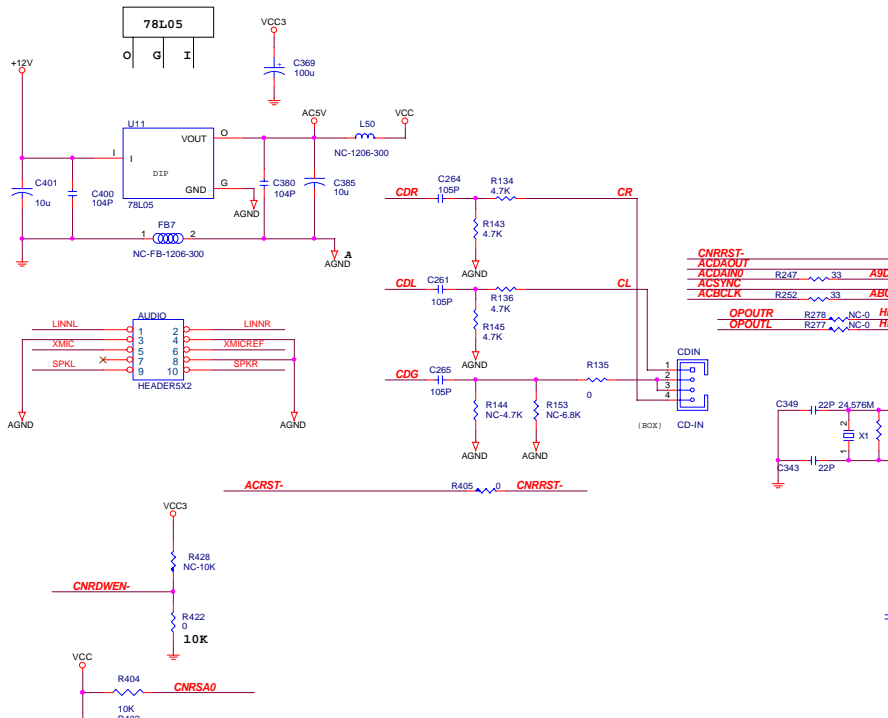

JET WAY INFORMATION			
File	AC97 & CNR & FWH		
Size	Document Number	845CA	Rev 3.0
Date	Friday, December 28, 2001	Sheet	10 of 15

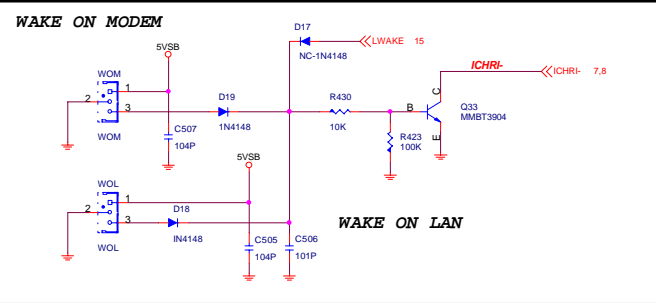
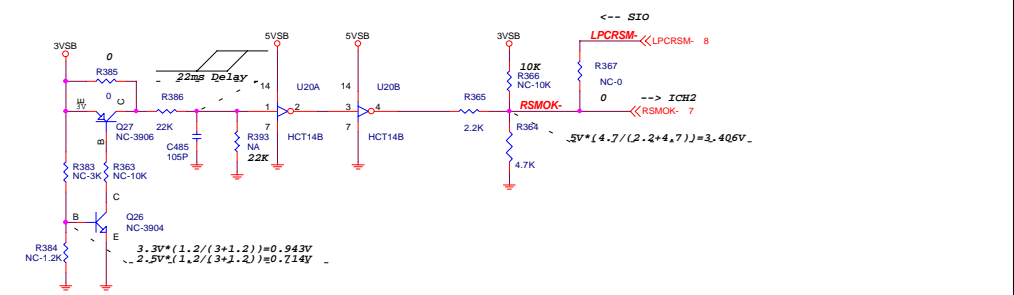
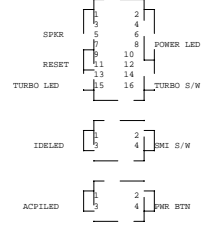
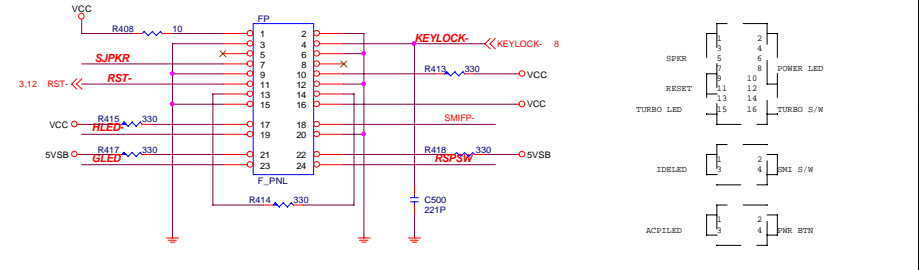
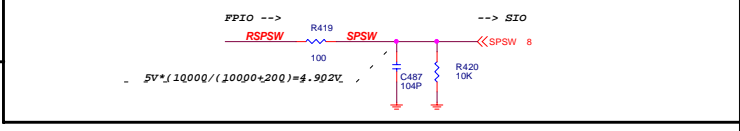
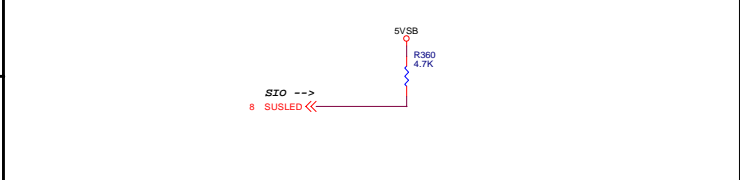
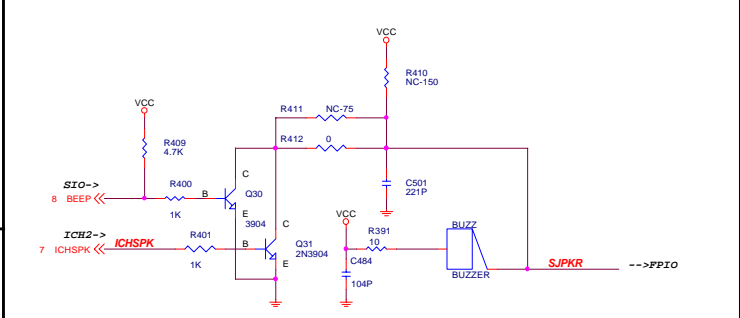
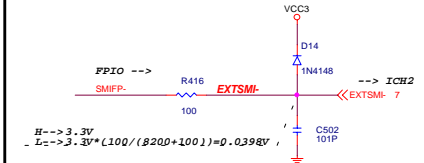
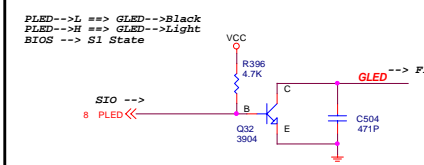
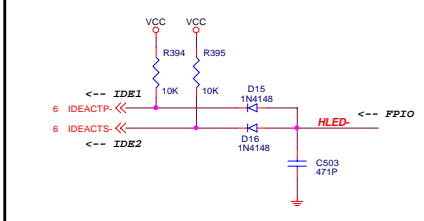
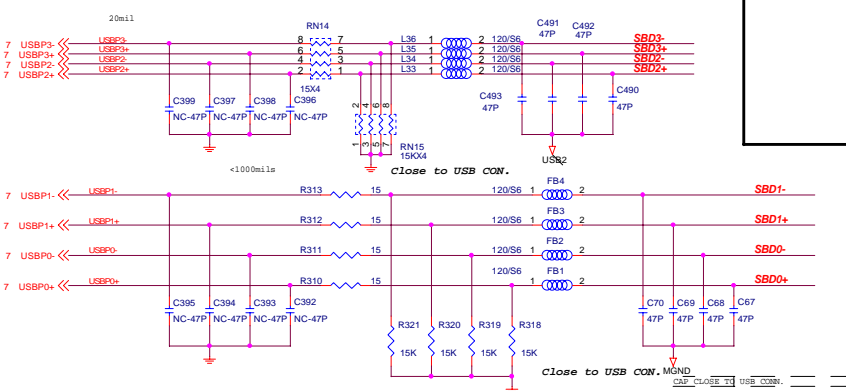
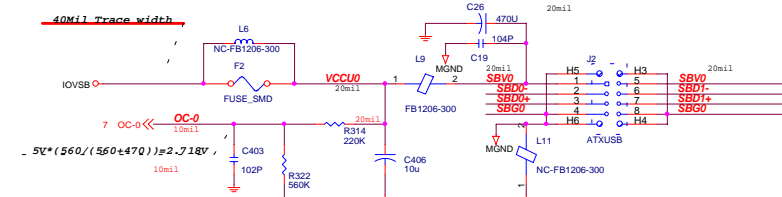
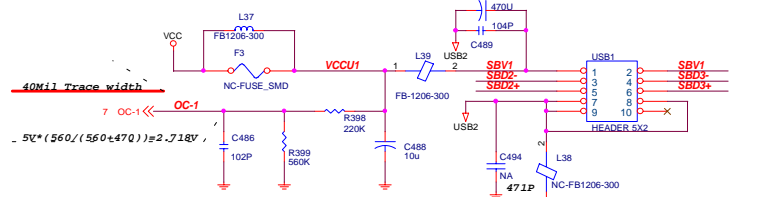
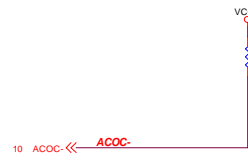

JET WAY INFORMATION			
File	USB & FTP		
Size	Document Number	845CA	Rev 5.0
Date	Friday, December 28, 2001	Sheet	11 of 15

VID4	VID3	VID2	VID1	VID0	VCOEFF
1	1	1	1	1	1.100
1	1	1	0	1	1.125
1	1	0	1	0	1.150
1	1	0	1	1	1.175
1	1	0	0	1	1.200
1	1	0	0	0	1.225
1	0	1	1	0	1.250
1	0	1	1	1	1.275
1	0	1	0	0	1.300
1	0	1	0	1	1.325
1	0	0	1	0	1.350
1	0	0	1	1	1.375
1	0	0	0	1	1.400
1	0	0	0	0	1.425
0	1	1	1	1	1.450
0	1	1	1	0	1.475
0	1	1	0	1	1.500
0	1	1	0	0	1.525
0	1	0	1	1	1.550
0	1	0	1	0	1.575
0	1	0	0	1	1.600
0	1	0	0	0	1.625
0	0	1	1	1	1.650
0	0	1	1	0	1.675
0	0	1	0	1	1.700
0	0	1	0	0	1.725
0	0	0	1	1	1.750
0	0	0	1	0	1.775
0	0	0	0	1	1.800
0	0	0	0	0	1.825
0	0	0	0	0	1.850

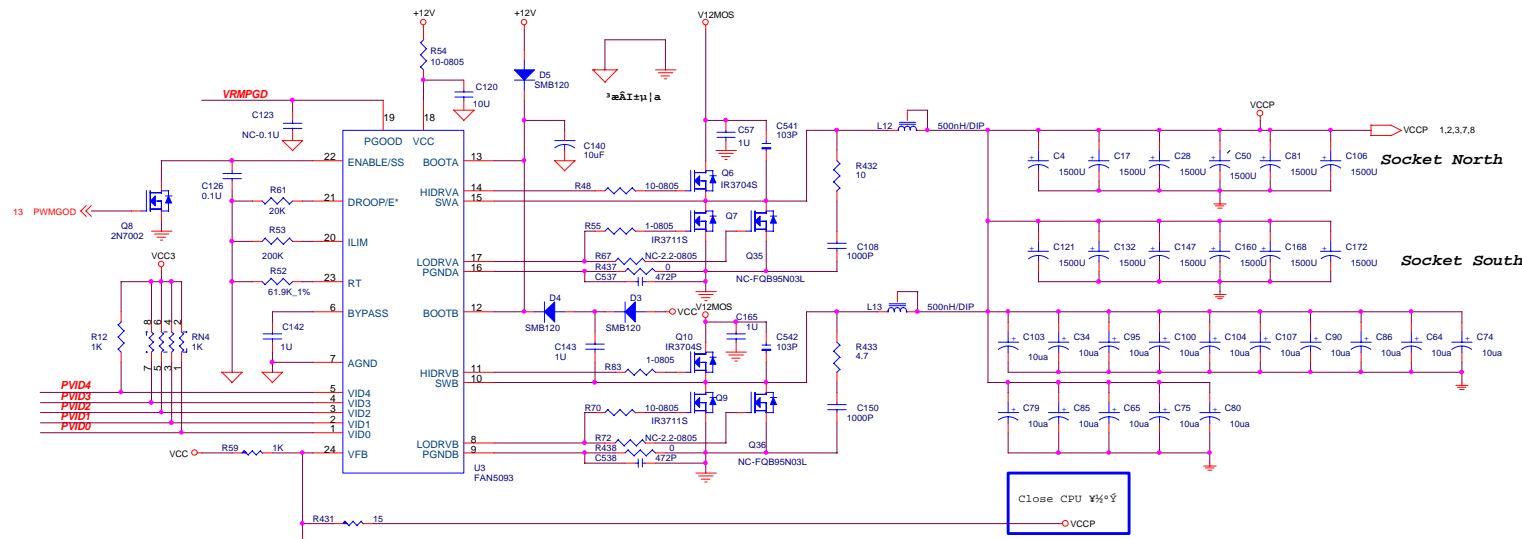

Close CPU V_{CC}

Default VCCP = 1.725V

VID[4..0]=1.1.1.1,VCCP->0.000V
VID[4..0]=0.0.0.0,VCCP->1.850V

Place Caps Close +12VPOWER Pin

Place Caps Close ATXPOWER Pin

TO PWM
REGULATOR
and I/O
WHM

VID Adjustable Function

12VATXPOWER SPEC. Ver. 1.0

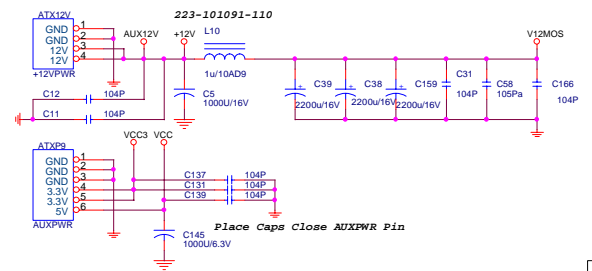
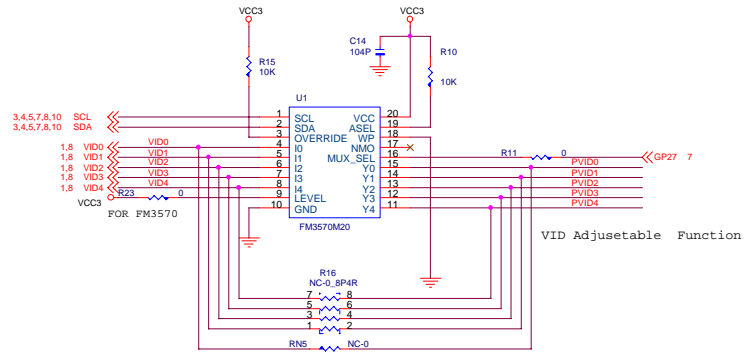

Place Caps Close AUXVWR Pin

JET WAY INFORMATION		
HIP6303/ATX12V		
Size C	Document Number	Rev
	845CA	3.0
Date:	Friday, December 28, 2001	Sheet 12 of 15

