

24 bit, 96 kHz Stereo A/D Converter

Features

- 24-bit I²S audio data format output
- Single power supply 3.3 V for analog and digital
- Single-ended analog input with internal anti-alias filter
- SNR: 98 dB (A-weighted)
- DR: 99 dB (A-weighted)
- THD: -91 dB
- Master/slave mode selection
- Multiple sampling frequencies (F_S): 8~96 kHz
- System clock: 128 F_S, 256 F_S, 384 F_S, 512 F_S
- Power down function
- Internal PLL
- 16-pin TSSOP package

input signals into 24-bit I²S digital audio data through on-chip anti-aliasing filter, multi-bit Σ - Δ modulator, decimation filter and high-pass filter which removes dc offsets. The AD12250A supports sampling frequencies from 8 kHz to 96 kHz and offers 128 F_S, 256 F_S, 384 F_S or 512 F_S system clock operation modes depending on sampling frequency and master/slave mode selection. The AD12250A is suitable for digital audio media applications which require high performance A/D conversion and low system cost.

Applications

- DVD recorders
- CD recorders
- MD players
- HDD players
- A/V receivers
- Personal Video recorders
- Musical Instrument
- Automotive audio applications

ORDERING INFORMATION

Product Number	Package	Comments
AD12250A-SG	16L TSSOP 4.4mm	Pb-free

Description

The AD12250A converts stereo single-ended analog

Functional Block Diagram

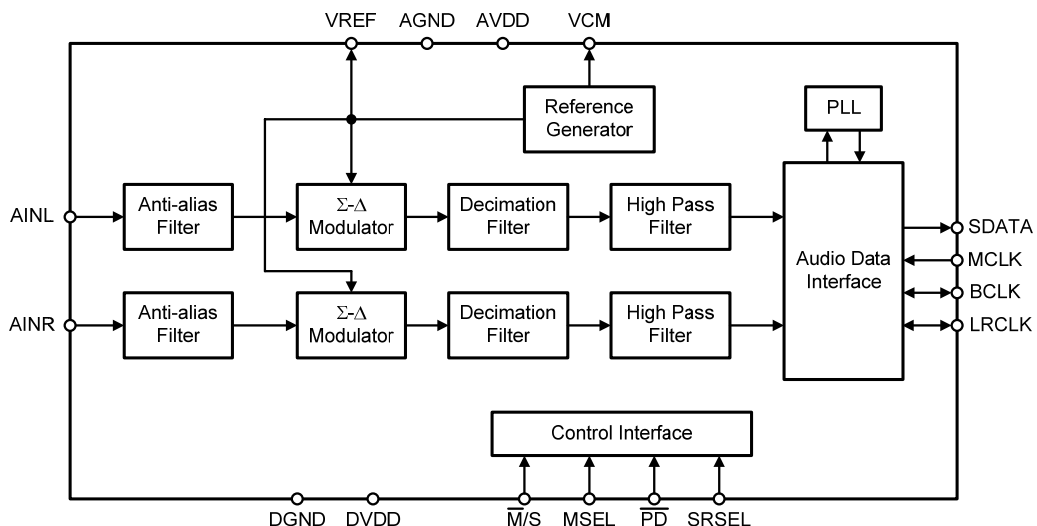

Pin Assignment

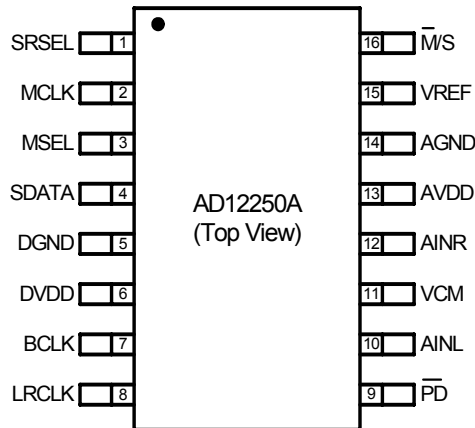

Pin Description

Pin	Name	Type	Description	Characteristics
1	SRSEL	I	48kHz/96kHz sample rate selection	Schmitt trigger input buffer
2	MCLK	I	Master clock input	Schmitt trigger input buffer
3	MSEL	I	MCLK divided-by-2 selection in master mode	Schmitt trigger input buffer
4	SDATA	O	Serial audio data output	
5	DGND	P	Digital ground	
6	DVDD	P	Digital supply	
7	BCLK	I/O	Bit clock input/output (64Fs)	Schmitt trigger input buffer
8	LRCLK	I/O	Left/Right clock input/output (Fs)	Schmitt trigger input buffer
9	$\overline{\text{PD}}$	I	Power down, low active	Schmitt trigger input buffer
10	AINL	I	Left channel analog input	
11	VCM	O	Common-mode voltage	
12	AINR	I	Right channel analog input	
13	AVDD	P	Analog supply	
14	AGND	P	Analog ground	
15	VREF	O	Positive reference voltage	
16	$\overline{\text{M/S}}$	I	Master/Slave mode selection	Schmitt trigger input buffer

Package Options

Package Type	Part Number	Thermal Information
16L TSSOP 4.4mm	AD12250A-SG	$\theta_{JA} \cong 60 \text{ }^\circ\text{C/W}$ (Condition: still air)

Absolute Maximum Ratings

Symbol	Parameter	Min	Max	Units
DVDD	Supply for Digital Circuit	0	3.6	V
AVDD	Supply for Analog Circuit	0	3.6	V
	Analog Input Voltage	AGND	AVDD	V
	Digital Input Voltage	DGND	DVDD	V
T _{stg}	Storage Temperature	-65	150	°C
T _a	Ambient Operating Temperature	-40	85	°C

Recommended Operating Conditions

Symbol	Parameter	Min	Typ	Max	Units
DVDD	Supply for Digital Circuit	3.0	3.3	3.6	V
AVDD	Supply for Analog Circuit	3.0	3.3	3.6	V
T _a	Ambient Operating Temperature	0		70	°C

Digital Characteristics

Symbol	Parameter	Min	Typ	Max	Units
V _{IH}	High-Level Input Voltage	2.0			V
V _{IL}	Low-Level Input Voltage			0.8	V
V _{OH}	High-Level Output Voltage	2.4			V
V _{OL}	Low-Level Output Voltage			0.4	V
C _i	Input Capacitance		6.4		pF

Power Supply Characteristics

- Condition: T_A = 25 °C, F_S = 48 kHz, MCLK = 256 F_S, slave mode, full-scale 1 kHz input signal

Symbol	Parameter	Condition	Min	Typ	Max	Units
AVDD	Supply for Analog Circuit		3.0	3.3	3.6	V
DVDD	Supply for Digital Circuit		3.0	3.3	3.6	V
I _A	Analog Power Supply Current	AVDD = 3.3 V		18		mA
I _D	Digital Power Supply Current	DVDD = 3.3 V		12		mA
P _C	Power Consumption	Normal Operation, AVDD, DVDD = 3.3 V		99		mW
		Power Down		<0.5		μW
PSRR	Power Supply Rejection Ratio (Note1)	1 kHz signal at AVDD		56		dB

Note1: PSRR = 56dB for 1μF capacitor on VCM pin and 36dB for 0.1μF capacitor on VCM pin.