

Design Idea DI-11

TinySwitch-II[®]

Buck Converter



Application	Device	Power Output	Input Voltage	Output Voltage	Topology
General Purpose	TNY264P	1.2 W	85-265 VAC	12 V	Buck

Design Highlights

- Lowest cost non-isolated switch mode converter
- Entirely producible in SMD (13 components)
- No transformer required
- Meets 2005 European 300 mW no-load consumption requirement
- Meets EN55022B/CISPR22
- Universal input voltage range (85–265 VAC)
- Short circuit and thermally protected
- Excellent line and load regulation
- Less than 10 ms startup time

Operation

The *TinySwitch-II* buck converter supply provides a non-isolated 12 V output rated at 100 mA. The design shown takes advantage of many of the built-in features of the TNY264.

AC input voltage is rectified and filtered by D1, C1 and C2 to create a high voltage DC bus which is connected to the input of the buck stage. The fusible, flameproof resistor R1 is used in place of a fuse to reduce system cost and it also provides differential mode noise filtering. With the integrated frequency jitter it is possible to meet international conducted EMI requirements with a simple PI-filter formed by C1, L1 and C2.

The freewheeling diode D2, the inductance L2 and the output capacitor C4 form the buck stage. Zener diode VR1 and the forward drop of the optocoupler diode U2 determine the output voltage.

The built-in auto-restart function of *TinySwitch-II* protects the output in case of short circuit or an open control loop condition by reducing the delivered power to less than 6% of the nominal output power.

Key Design Points

- Preferred discontinuous mode of operation is accomplished by limiting the output current to 50% of the minimum internal current limit.

$$L_2 \geq \begin{cases} L_{\text{MIN_PWR}} \\ L_{\text{MIN_SOA}} \end{cases} \quad (\text{see Table 1})$$

- The voltage rating of L2 has to be greater than $\sqrt{2} \times V_{\text{ACMAX}}$.
- Size capacitors C1 and C2 according to the output power and surge withstand requirements.
- Optocoupler U2 provides level shifting only and therefore doesn't need to be safety rated.
- Select output capacitor C4 according to the ripple requirement: $\text{ESR}_{\text{C4}} \leq V_{\text{OUT_RIPPLE}} / I_{\text{LIMIT}}$.
- Minimum recommended output voltage is 5 V (smaller voltages may cause non-preferred continuous mode operation.)
- Diode D2 must be an ultrafast type $t_{\text{rr}} \leq 35 \text{ ns}$.

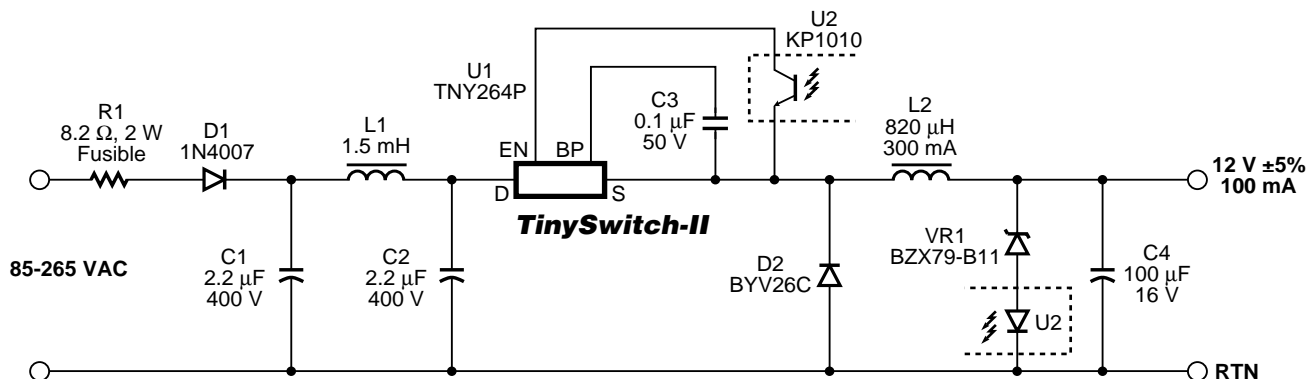

Figure 1. *TinySwitch-II* 12 V, 1.2 W Buck Converter.

PI-2780-081301

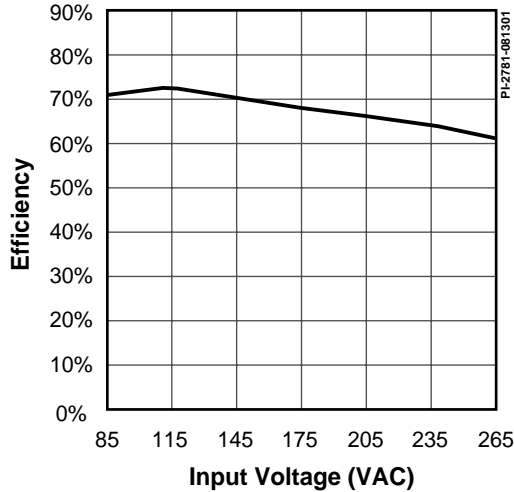

Figure 2. Efficiency vs. input voltage.

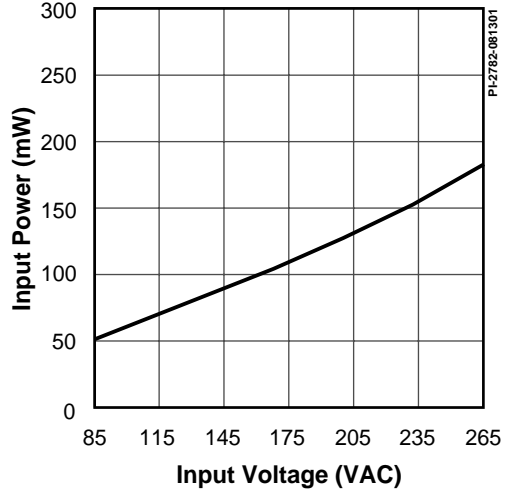

Figure 3. No-load input power vs. input voltage.

$$L_{MIN_PWR} \geq \frac{2 \cdot P_O \cdot (\sqrt{2} \cdot V_{ACMAX} - V_{DS} - V_O)}{I_{LIMIT_MIN}^2 \cdot f_{SW_MIN} \cdot (\sqrt{2} \cdot V_{ACMAX} - V_{DS})}$$

Part No.	I _{O_MAX}	85-265 VAC L _{MIN_SOA}	85-132 VAC L _{MIN_SOA}
TNY264	115 mA	820 μH	470 μH
TNY266	162 mA	680 μH	330 μH
TNY267	210 mA	560 μH	330 μH
TNY268	256 mA	470 μH	220 μH

Table 1. L_{MIN_SOA} and I_{O_MAX} (discontinuous mode).

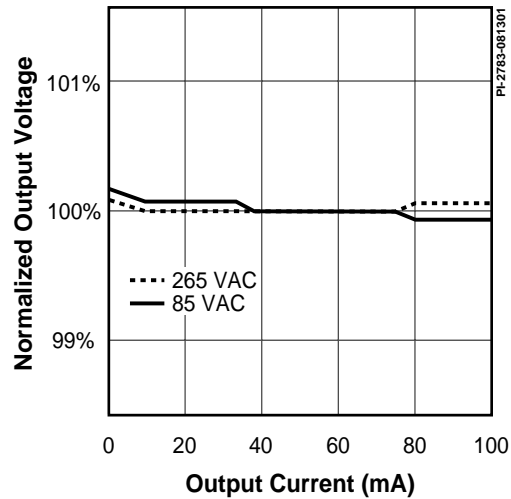

Figure 4. Load regulation at 85 VAC and 265 VAC.

For the latest updates, visit our Web site: www.powerint.com

Power Integrations reserves the right to make changes to its products at any time to improve reliability or manufacturability. Power Integrations does not assume any liability arising from the use of any device or circuit described herein, nor does it convey any license under its patent rights or the rights of others.

The PI Logo, **TOPSwitch**, **TinySwitch** and **EcoSmart** are registered trademarks of Power Integrations, Inc.

©Copyright 2001, Power Integrations, Inc.

**WORLD HEADQUARTERS
AMERICAS**

Power Integrations, Inc.
San Jose, CA 95138 USA
Customer Service:
Phone: +1 408-414-9665
Fax: +1 408-414-9765
e-mail: usasales@powerint.com

EUROPE & AFRICA

Power Integrations (Europe) Ltd.
United Kingdom
Phone: +44-1344-462-300
Fax: +44-1344-311-732
e-mail: eurosales@powerint.com

TAIWAN

Power Integrations
International Holdings, Inc.
Taipei, Taiwan
Phone: +886-2-2727-1221
Fax: +886-2-2727-1223
e-mail: taiwansales@powerint.com

CHINA

Power Integrations
International Holdings, Inc.
China
Phone: +86-755-367-5143
Fax: +86-755-377-9610
e-mail: chinasales@powerint.com

KOREA

Power Integrations
International Holdings, Inc.
Seoul, Korea
Phone: +82-2-568-7520
Fax: +82-2-568-7474
e-mail: koreasales@powerint.com

JAPAN

Power Integrations, K.K.
Keihin-Tatemono 1st Bldg.
Japan
Phone: +81-45-471-1021
Fax: +81-45-471-3717
e-mail: japansales@powerint.com

INDIA (Technical Support)

Innovatech
Bangalore, India
Phone: +91-80-226-6023
Fax: +91-80-228-9727
e-mail: indiasales@powerint.com

APPLICATIONS HOTLINE

World Wide +1-408-414-9660

APPLICATIONS FAX

World Wide +1-408-414-9760

