

## DN83

# LED MR16 Lamp solution using the ZXLD1350 LED driver

Neil Chadderton, Colin Davies, Roger Heap, Zetex Semiconductors

---

### Introduction

Lighting class LEDs are now available that deliver the brightness, efficacy, lifetime, color temperature, and white point stability required for general illumination. As a result, these LEDs are being adopted into most general lighting applications including roadway, parking area and indoor directional lighting. LED-based luminaires reduce Total-Cost-of-Ownership (TCO) in these applications through maintenance avoidance and reduced energy costs.

MR16 lamps are one variety of Multifaceted Reflector (MR) lamps that have traditionally employed a halogen filament capsule as the light source. They are used in many retail and consumer lighting applications where their size, configurability, spot-lighting capability and aesthetics provide utility and creativity. Their low efficiency, heat generation (an issue for illuminating heat sensitive subjects and materials) and halogen capsule handling issues are typically cited among the disadvantages of the technology. They typically operate from 12V AC or 12V DC, though designs for 6V to 24V are also popular and as such require a step-down transformer to allow use from offline supplies. This is usually effected with conventional electromagnetic or electronic transformers.

With the advancement of HB (High Brightness) LED technologies, MR16 lamps can now be realized with an alternate light source. This hybrid solution can yield a cost effective, long-life, maintenance free, cooler operating unit which has not been previously possible.



Image courtesy of Lighting Research Center

**Figure 1 MR16 Lamps (Incandescent A-lamp on far right shown for size comparison)**

# DN83

## Description

This design note describes a driver solution developed using the Zetex ZXLD1350 LED driver IC to drive three Cree® XLamp XR-E High Brightness (HB) LEDs.

The **ZXLD1350** features can be summarized as:

- Wide input voltage range
- 7V to 30V; internal 30V NDMOS switch
- Up to 350mA output current (the ZXLD1360 can provide up to 1A output current)
- Capable of driving up to 8 series connected 1 Watt LEDs
- High efficiency (see datasheet - but >90% with 8 LEDs)
- Low quiescent current: (100 $\mu$ A typical)
- 1A max shutdown current
- Brightness control using DC voltage or PWM (low or high frequency)
- Internal PWM filter for high frequency PWM signals
- Optional soft-start; up to 1MHz switching frequency

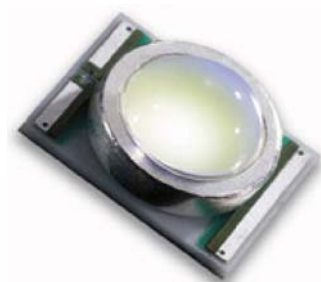

The Cree **XR-E** LED is a lighting class device that provides energy savings for many traditional technologies such as the MR16 halogen lamp. The XR-E LED is capable of operating at forward currents of up to 1A without any noticeable shifts in chromaticity. The XR-E is ideally suited for direct replacement of MR16 when used in clusters of three at a forward current of 300mA—1000mA. They are specified at 80 lumens and 70 lumens per watt at 350mA (136 lumens at 700mA). These lighting class LEDs offer efficient, directional light that offers a lumen maintenance of 70% at 50,000 hours, in addition to significantly reducing power consumption.

The circuit diagram of the ZXLD1350 effected MR16 lamp solution is shown in *Figure 2*. *Table 1* provides the bill of materials. A full bridge (D1—D4) is employed using 1A DC rated, low leakage Schottky diodes to allow AC or DC input supplies. A thermistor circuit is incorporated to reduce the output current of the circuit to provide thermal feedback control, which allows the circuit to a) match the thermal de-rating requirements of the LEDs to ensure lumen maintenance expectations are achieved and b) prevent overheating. The thermistor must be thermally coupled to the LEDs to ensure accurate and responsive tracking. Adjustment of the thermal feedback circuit can be accomplished by the choice of the thermistor R3 - which sets the slope of the current vs. temperature response, and resistor R2 - which determines the temperature threshold point for the control circuit. R1 and D5 provide a reference voltage for the thermal control circuit. Q1 is a low  $V_{CE(sat)}$  PNP transistor. Schottky diode D9 is again a low leakage 1A rated device in a SOT23 package - its low forward voltage and low reverse current ensure high efficiency and thermal stability in the main switching circuit. C3 may be added to reduce the amplitude of the current ramp waveform experienced by the LED string but in many applications this isn't required as the integrating nature of human sight cannot perceive quickly changing light levels. Depending on layout intricacies and EMC dictates, it may be necessary to exchange the positions of the inductor and LED string - this isn't always possible mechanically but does give a lower EMI signature.

Figure 3 shows the measured response of the LED current drive with respect to temperature, with the values given in Table 2. The selection of components for the thermal feedback circuit is not only dependent on the choice of R2 and R3, but also on the amount of heat sink area required to extract heat from the LEDs. To maximize the light output at high ambient or operating temperature conditions, the LEDs must have a sufficient thermal extraction path, otherwise the thermal control circuit will effect current drive reduction in non-optimal conditions. The thermal control threshold point is set by adjusting R2. For this design, three values (33k, 22k and 10k) were evaluated. These values were chosen to give break points at approximately 25°C, 40°C and 60°C. Note that the light output will not continually dim to zero - the thermal control is applying DC control to the ADJ pin and therefore has a dimming ratio from maximum current of approximately 5:1. Once the reduced DC level goes below the shutdown threshold of around 200mV, the LED drive current will fall to zero and the LEDs will be extinguished. The slope of the current reduction is determined by the beta value of the thermistor. The larger the beta value, the sharper will be the resultant current control response. The slope of the current reduction is also affected by Q1's base emitter voltage ( $V_{BE}$ ) variation with temperature. Figure 3 shows the slope starts to level off at higher temperatures due to the increasing influence of the approximately -2.2mV/°C change in the  $V_{BE}$  of the transistor.

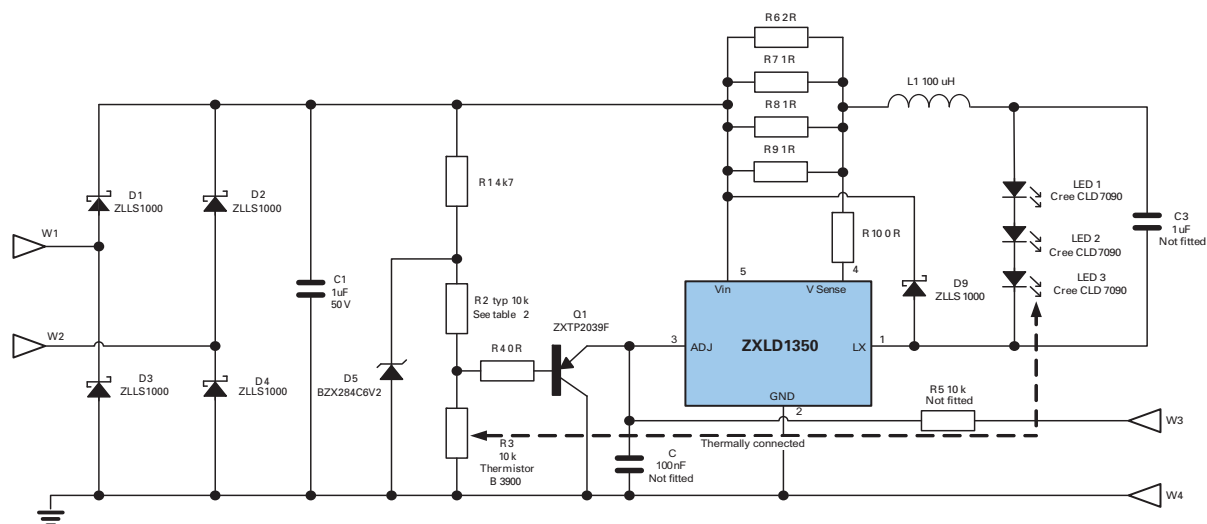

**Figure 2 Circuit diagram of ZXLD1350 MR16 lamp solution**

# DN83

Measured results for circuit of Figure 2 using 10k thermistor with beta of 3900

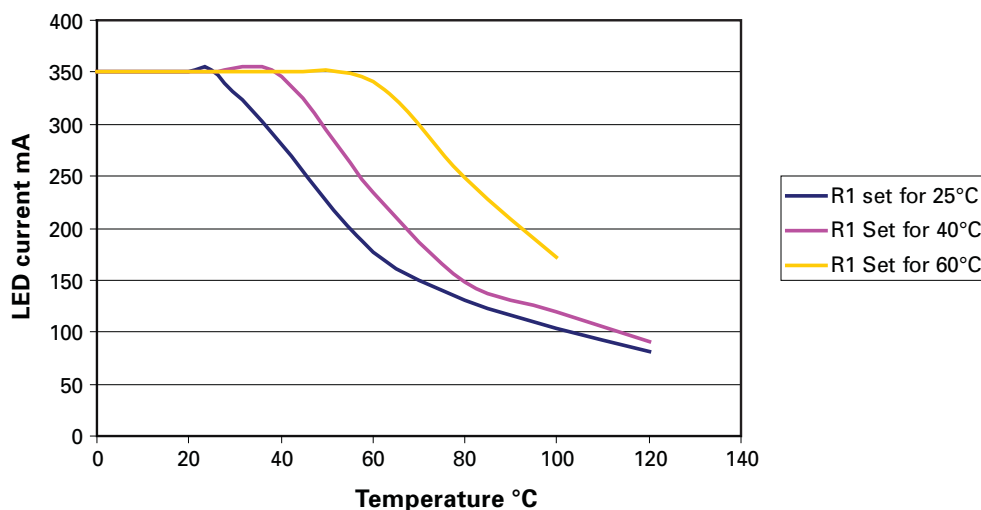

Figure 3 Measured response of thermal feedback control showing threshold point

Quantity	Part reference	Value	Description	Source
1	R1	4k7	Resistor, 1%, 0603	Various
1	R2	See Table 2 0603 resistor	Resistor, 1% 0603	Various
1	R3	10K, 0603, Beta = ~3900 thermistor	Thermistor, 5% 0603	EPCOS
1	R4	0R, 0603 link	0R Link, 0603	Various
1	R5	10k, 0603 resistor	Generic	Various
1	R6	2R, 0603 resistor	Generic	Various
3	R7, R8, R9	1R, 0603 resistor	Generic	Various
	R10	0R 1206 link	0R Link, 1206	Various
5	D1, D2, D3, D4, D9	ZLLS1000	Schottky diode 40V, 1A	Zetex
1	D5	BZX284C6V2	6.2V Zener diode	
1	C1	1uF	Capacitor 50v 1206X7R NMC1206X7R105K50F C1206C105K5RAC7800	NICcomponents KEMET
2	C2, C3		Not fitted	
3	LED1, LED2, LED3	XR-E	Cree XLamp power LED	Cree
1	Q1	ZXTP2039F	Transistor, PNP Alternative: FMMT717	Zetex
1	L1	100µH	MSS6132 100µH NPIS53D101MTRF	Coilcraft NIC components
1	IC1	ZXLD1350	Zetex LED driver IC	Zetex

Table 1 Bill of materials

	R2 = 33k	R2 = 22k	R2 = 10k
Temp.	R1 set for 25°C	R1 set for 40°C	R1 set for 60°C
0	350	350	350
20	350	350	350
25	352	350	350
40	280	345	350
60	177	235	342
80	131	148	248
100	104	120	171
120	81	90	

**Table 2: Thermal feedback control threshold point (resistor R2)**

For three series-connected LEDs, the voltage can be from 12V minimum to 30V DC maximum. For AC supplies, remember to include the 1.414 factor for RMS specified values - so for 20V AC (RMS), this will provide a DC rail after the Schottky bridge of 28.3V. The nominal current is set at 350mA with a 0.283Ω sense resistor. The sense resistor is a combination component using 4 low cost, commonly available values and allows current set point flexibility if the circuit is used as a platform design for a series of products. For three series-connected LEDs, with a nominal supply of 24V and a 100μH inductor, the ZXLD1350 runs in continuous mode at approximately 500kHz. The ZXLD1350 datasheet displays this information graphically, as shown in Figure 4 (for a sense resistor of 330mΩ in this case), which allows a fast assessment to be made of operating conditions. The switching frequency will increase as the voltage on the ADJ pin decreases. As the ZXLD1350 (and ZXLD1360) series of LED drivers use a hysteretic switching topology, the switching frequency is dependent on several factors - input voltage, target current (including any effect by voltage on the ADJ pin to reduce the current) and number of LEDs. An Excel based calculator is available which allows "what-if" initial evaluation and is a useful tool for assessing component and condition changes. Final designs should, of course, be verified by reality.

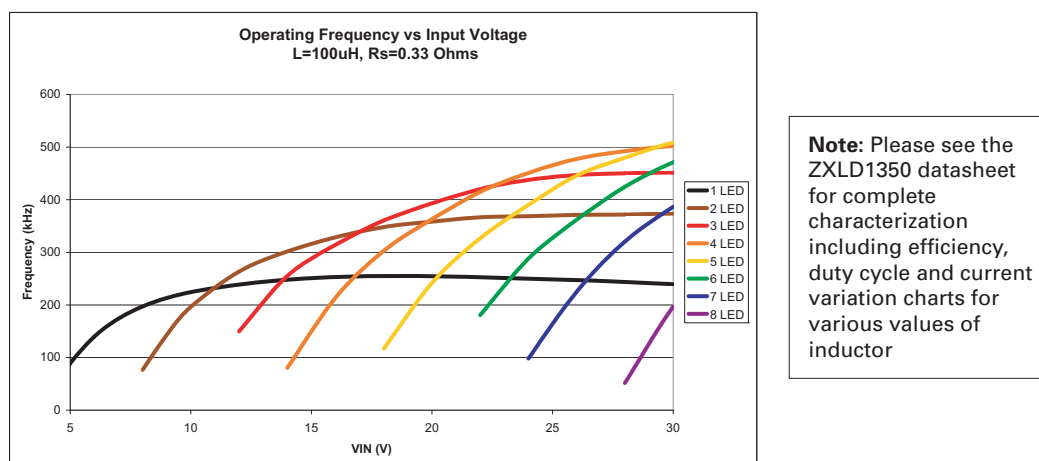

**Figure 4 Example of operating frequency chart for the ZXLD1350**

# DN83

## Higher current designs

The ZXLD1350 is designed for LED current drive applications of up to 350mA. The monolithic N-MOSFET is sized appropriately to provide a cost-effective die size and is rated to 400mA, which with the hysteretic mode of operation (the current waveform will ramp  $\pm 15\%$  about the nominal current set point) provides sufficient margin. For higher current operation, the 1A rated **ZXLD1360** offers similar design procedures and has the following features:

- Up to 1A output current
- Wide input voltage range: 7V to 30V
- Internal 30V 400m NDMOS switch
- Can drive up to 7 series connected 3W LEDs (with due attention to thermal path design)
- High efficiency (>90% for 7 LEDs)
- Brightness control using DC voltage or PWM
- Internal PWM filter
- Optional soft-start
- Up to 1MHz switching frequency

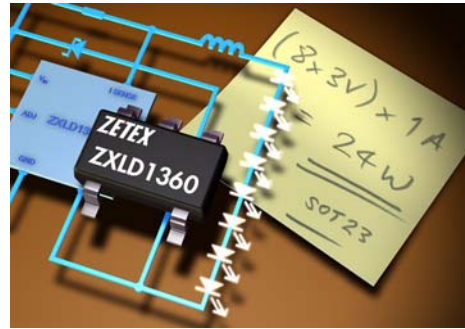

## Board design

The Printed Circuit Board (PCB) design and circuit employed make it particularly suitable for use in MR16 halogen lamp replacement units. The supply voltage range is nominally 12V AC or DC, making it compatible and interchangeable with existing MR16 lamps. The printed circuit tracking has been designed using only one side of the board, to facilitate the use of an aluminum or other heat-conductive substrate where through-hole technology cannot be employed. A central hole is provided to enable connection of the supply leads from the rear and for connection to a dimming circuit, where this is required. Mounting holes are also provided. Gerber-format layout files for this PCB are available from Zetex upon request. Please quote PCB number ZDB335.

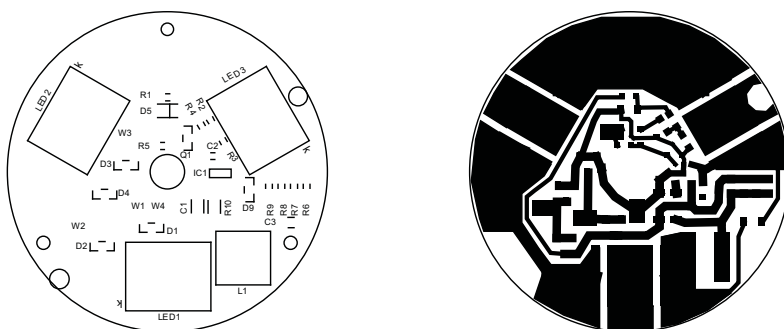

Top PCB overlay

Top copper

Figure 5 Top PCB overlay and top copper

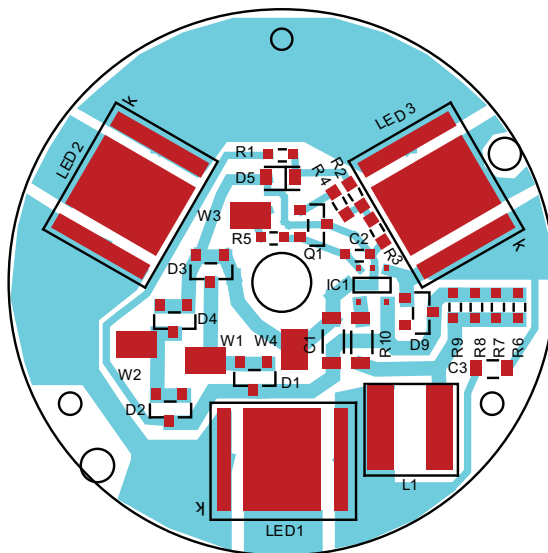

Figure 6 Composite view

## Appendix A - ZXLD1350 operation

In normal operation, when voltage is applied at  $+V_{CC}$ , the ZXLD1350 internal NDMOS switch is turned on. Current starts to flow through the sense resistor, inductor L1, and the LEDs. The current ramps up linearly, and the ramp rate is determined by the input voltage  $+V_{CC}$  and the inductor L1. This rising current produces a voltage ramp across the sense resistor. The internal circuit of the ZXLD1350 senses the voltage across the sense resistor, and applies a proportional voltage to the input of the internal comparator. When this voltage reaches an internally set upper threshold, the NDMOS switch is turned off. The inductor current continues to flow through the sense resistor, L1, the LEDs, the Schottky diode SD9, and back to the supply rail, but it decays, with the rate of decay determined by the forward voltage drop of the LEDs and the Schottky diode. This decaying current produces a falling voltage at the sense resistor, which, in turn, is sensed by the ZXLD1350. A voltage proportional to the sense voltage across the sense resistor is applied at the input of the internal comparator. When this voltage falls to the internally set lower threshold, the NDMOS switch is turned on again. This switch-on-and-off cycle continues to provide the average LED current set by the sense resistor.

Both DC and PWM dimming can be achieved by driving the ADJ pin through W3. For DC dimming, the ADJ pin may be driven between 300mV and 1.25V. Driving the ADJ pin below 200mV will shutdown the output current. For PWM dimming, an external open-collector NPN transistor or open-drain N-channel MOSFET can be used to drive the ADJ pin. The PWM frequency can be low, around 100Hz to 300Hz, or high between 10kHz to 50kHz. For the latter case, an on-chip filter derives the DC content and so for high frequency PWM input, the device will operate essentially as for DC control input dimming. Generally, low frequency PWM control is preferred as in this mode, the converter is shut down during PWM low signals and drives the LEDs at the defined nominal current during PWM high signals - this ensures that the LEDs can be always driven at the nominal current and therefore color temperature (CCT) shifts are minimized. The capacitor C2 should be around 10nF to decouple high frequency noise at the ADJ pin for DC dimming. Note - C2 should not be fitted when using the PWM dimming feature. The soft-start time will be nominally 0.5ms without capacitor C2. Adding C2 will increase the soft start time by approximately 0.5ms/nF

Please refer to the datasheets for the threshold limits, ZXLD1350 internal circuits, electrical characteristics and parameters.



Intentionally left blank

# DN83

---

## Definitions

### Product change

Zetex Semiconductors reserves the right to alter, without notice, specifications, design, price or conditions of supply of any product or service. Customers are solely responsible for obtaining the latest relevant information before placing orders.

### Applications disclaimer

The circuits in this design/application note are offered as design ideas. It is the responsibility of the user to ensure that the circuit is fit for the user's application and meets with the user's requirements. No representation or warranty is given and no liability whatsoever is assumed by Zetex with respect to the accuracy or use of such information, or infringement of patents or other intellectual property rights arising from such use or otherwise. Zetex does not assume any legal responsibility or will not be held legally liable (whether in contract, tort (including negligence), breach of statutory duty, restriction or otherwise) for any damages, loss of profit, business, contract, opportunity or consequential loss in the use of these circuit applications, under any circumstances.

### Life support

Zetex products are specifically not authorized for use as critical components in life support devices or systems without the express written approval of the Chief Executive Officer of Zetex Semiconductors plc. As used herein:

A. Life support devices or systems are devices or systems which:

1. are intended to implant into the body

or

2. support or sustain life and whose failure to perform when properly used in accordance with instructions for use provided in the labelling can be reasonably expected to result in significant injury to the user.

B. A critical component is any component in a life support device or system whose failure to perform can be reasonably expected to cause the failure of the life support device or to affect its safety or effectiveness.

---

### Reproduction

The product specifications contained in this publication are issued to provide outline information only which (unless agreed by the company in writing) may not be used, applied or reproduced for any purpose or form part of any order or contract or be regarded as a representation relating to the products or services concerned.

---

### Terms and Conditions

All products are sold subjects to Zetex' terms and conditions of sale, and this disclaimer (save in the event of a conflict between the two when the terms of the contract shall prevail) according to region, supplied at the time of order acknowledgement.

For the latest information on technology, delivery terms and conditions and prices, please contact your nearest Zetex sales office .

---

### Quality of product

Zetex is an ISO 9001 and TS16949 certified semiconductor manufacturer.

To ensure quality of service and products we strongly advise the purchase of parts directly from Zetex Semiconductors or one of our regionally authorized distributors. For a complete listing of authorized distributors please visit: [www.zetex.com/salesnetwork](http://www.zetex.com/salesnetwork)

Zetex Semiconductors does not warrant or accept any liability whatsoever in respect of any parts purchased through unauthorized sales channels.

---

### ESD (Electrostatic discharge)

Semiconductor devices are susceptible to damage by ESD. Suitable precautions should be taken when handling and transporting devices. The possible damage to devices depends on the circumstances of the handling and transporting, and the nature of the device. The extent of damage can vary from immediate functional or parametric malfunction to degradation of function or performance in use over time. Devices suspected of being affected should be replaced.

---

### Green compliance

Zetex Semiconductors is committed to environmental excellence in all aspects of its operations which includes meeting or exceeding regulatory requirements with respect to the use of hazardous substances. Numerous successful programs have been implemented to reduce the use of hazardous substances and/or emissions.

All Zetex components are compliant with the RoHS directive, and through this it is supporting its customers in their compliance with WEEE and ELV directives.

---

### Product status key:

"Preview"	Future device intended for production at some point. Samples may be available
"Active"	Product status recommended for new designs
"Last time buy (LTB)"	Device will be discontinued and last time buy period and delivery is in effect
"Not recommended for new designs"	Device is still in production to support existing designs and production
"Obsolete"	Production has been discontinued

---

### Datasheet status key:

"Draft version"	This term denotes a very early datasheet version and contains highly provisional information, which may change in any manner without notice.
"Provisional version"	This term denotes a pre-release datasheet. It provides a clear indication of anticipated performance. However, changes to the test conditions and specifications may occur, at any time and without notice.
"Issue"	This term denotes an issued datasheet containing finalized specifications. However, changes to specifications may occur, at any time and without notice.

---

### Zetex sales offices

Europe	Americas	Asia Pacific	Corporate Headquarters
Zetex GmbH Kustermannpark Balanstraße 59 D-81541 München Germany Telephone: (49) 89 45 49 49 0 Fax: (49) 89 45 49 49 49 europe.sales@zetex.com	Zetex Inc 700 Veterans Memorial Highway Hauppauge, NY 11788 USA Telephone: (1) 631 360 2222 Fax: (1) 631 360 8222 usa.sales@zetex.com	Zetex (Asia Ltd) 3701-04 Metroplaza Tower 1 Hing Fong Road, Kwai Fong Hong Kong Telephone: (852) 26100 611 Fax: (852) 24250 494 asia.sales@zetex.com	Zetex Semiconductors plc Zetex Technology Park, Chadderton Oldham, OL9 9LL United Kingdom Telephone: (44) 161 622 4444 Fax: (44) 161 622 4446 hq@zetex.com

© 2007 Published by Zetex Semiconductors plc